

MBC600 Series AC-DC/DC-DC Open-Frame Medical Power Supplies



Features

- 600 W standard, 420 W convection cooled
- Size: 5.0" x 8.0" x 1.6" (127.0 x 203.2 x 40.6 mm)
- High efficiency up to 94.0%
- Universal input voltage range: 90-277 VAC / 120-240 VDC
- Active power factor correction
- Less than 5 W dissipation at standby mode
- Parallel operation with active current sharing
- Digital control for circuit loop and power management
- Fully protected (OTP, OCP, OVP, SCP)
- PMBus™ for control, programming and monitoring
- Designed to meet Class B per CISPR 22 and EN 55022
- Approved to the latest version of the following medical safety standards: IEC 60601-1, EN 60601-1, CAN/CSA C22.2 No. 60601-1, ANSI/AAMI ES60601-1, 2 x MOPP
- CE marked LVD

Applications

- Diagnostic Equipment
- Drug Pump
- Dialysis
- Ultrasound
- Surgical Device
- Home Health Care
- Monitoring Devices
- Imaging Equipment
- Hospital Beds
- Therapy Devices

North America

+1-866.513.2839

Asia-Pacific

+86.755.29885888

Europe, Middle East

+353 61 225 977

tech.support@psbel.com
belpowersolutions.com

MBC600 Series

1 Ordering Information

MODELS	OUTPUT VOLTAGE (VDC)	MAX LOAD CONVECTION	MAX LOAD 300 LFM	MINIMUM LOAD	RIPPLE & NOISE	TOTAL REGULATION
MBC600-1012G	12 V	35.0 A	50.0 A	0 A	1%	± 2%
MBC600-1024G	24 V	17.5 A	25.0 A	0 A	1%	± 2%
MBC600-1048G	48 V	8.8 A	12.5 A	0 A	1%	± 2%
V_{fan} (all models)	12 V	1.0 A	1.0 A	0 A	1%	± 20%
V_{sb} (all models)	5 V	1.0 A	1.0 A	0 A	2%	± 2%

NOTES:

1. Peak current rating on V1 (main output) is 120% of max, lasting 3 second with max of 10% duty cycle.
2. Combined output power of V1 plus fan supply and standby supply should not exceed max power rating.
3. +/-20% tolerance of V_{fan} includes the factors of set point accuracy, line and load regulation.
4. Air flow over long edge (either direction) required for air flow rating. See mechanical drawing, Figure 7 on page 11.
5. More than 800K hours MTBF is to be calculated according to Bellcore TR-332 standard current edition at 25 °C.

2 Overview

The MBC600 SERIES AC-DC/DC-DC power supply can operate using AC or DC input. It is a highly efficient front-end power supply. The PFC stage adopts an analog controller in continuous conduction mode to achieve high power factor and high efficiency. The DC/DC stage is fully DSP controlled and employs soft switching resonant techniques in conjunction with synchronous rectification for high efficiency and better thermal control. With a wide input operational voltage range and minimal linear derating of output power with temperature, the MBC600 SERIES maximizes power availability in demanding server, network, and other high availability applications. The supply is convection cooled or fan cooled and ideally suited for integration with a matching airflow path. An active OR-ing MOSFET on the output ensures no reverse current and renders the supply ideally suited for operation in redundant power systems. The always-on standby output V_{sb} (5 Volts) provides power to external power distribution and management controllers. It is protected with an active OR-ing diode for maximum reliability. In addition, the PMBus allows full monitoring of the supply, including input and output voltage, current, power, and internal temperatures. Current share signal (V1_I_{share}) is used for current sharing, and the difference between two units is within 2.5 A if system load is more than 25% of full load. The current share signal (V1_I_{share}) voltage shall be a linear function $V_{cs} = 8 \times I_{out}/I_{max}$ for a single power supply. Example: for MBC600-1012G, VCS is 8 V at 50 A loading; I_{max} is 50 A of MBC600-1012G.

Figure 1 - MBC600 SERIES Block Diagram

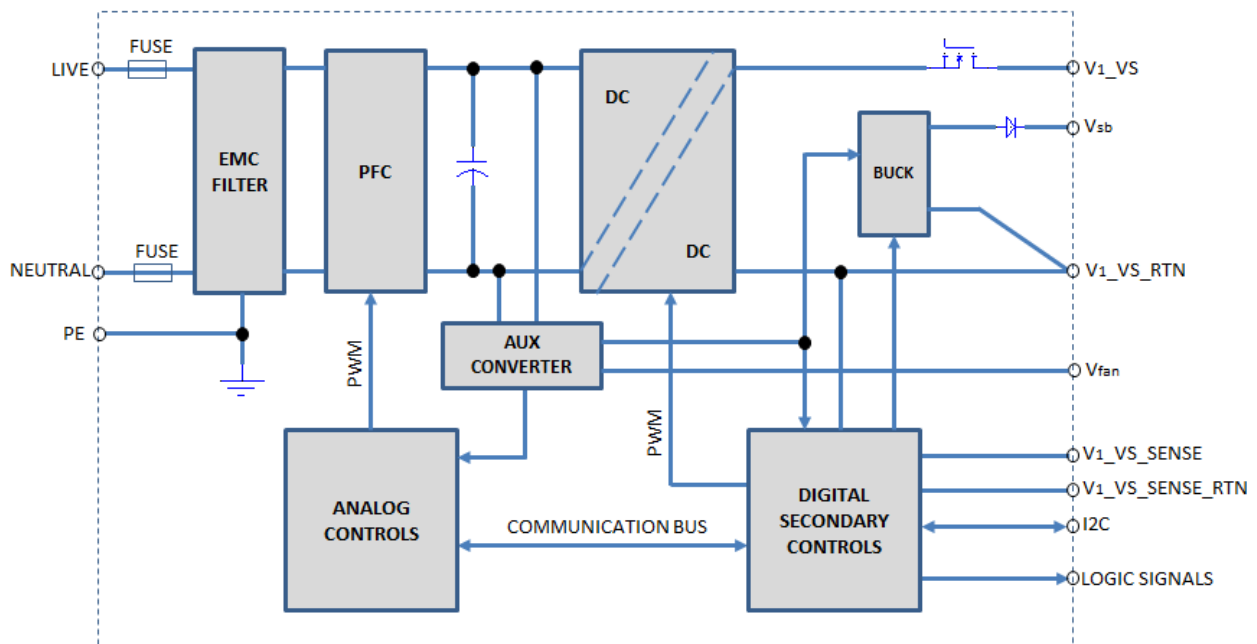

+1.866.513.2839

tech.support@psbel.com

belpowersolutions.com

MBC600 Series

3 Input

General Condition: $T_{amb} = -25$ to 70°C unless otherwise noted.

PARAMETER		DESCRIPTION / CONDITION	MIN	NOM	MAX	UNIT	
V_{in}	Input Voltage Ranges	Universal Input	90	100-250	277	VAC	
			120		240	VDC	
$I_{in\ max}$	Max Input Current	$V_{in} = 90$ VAC / 60 Hz, Full load			9	Arms	
I_{inrush}	Inrush Current Limitation	$V_{i\ min}$ to $V_{i\ max}$,			20	Apk	
F_i	Input Frequency		47	50/60	63	Hz	
PF	Power Factor	$V_{in\ nom}$, 50 Hz, > 50% full load.	0.95	0.99	1		
						$V_{in} = 230$ VAC, 20% of Full load, $T_{amb} = 25^{\circ}\text{C}$	91.0
						$V_{in} = 230$ VAC, 50% of Full load, $T_{amb} = 25^{\circ}\text{C}$	94.0
						$V_{in} = 230$ VAC, 100% of Full load, $T_{amb} = 25^{\circ}\text{C}$	93.0
P_{min}	Min Power at no Load	$V_{in} = 120$ VAC, $T_{amb} = 25^{\circ}\text{C}$, if diable V1			5	W	
$I_{leakage}$	Leakage Current	$V_{in} = 277$ VAC, $T_{amb} = 25^{\circ}\text{C}$, Input to Earth		250	300	μA	
T_{hold}	Hold-up Time	$V_{in} = 230$ VAC, Full load, V_{sb} within regulation, stay within $90\% \cdot V_{1\ nom}$ from AC zero point	16			mS	

4 Output

General Condition: $T_{amb} = -25$ to 70°C unless otherwise noted.

PARAMETER		DESCRIPTION / CONDITION	MIN	NOM	MAX	UNIT
Main Output V_1						
$V_1\ set$	Output Set point Accuracy	$0.5 \cdot I_{1\ nom}$, $T_{amb} = 25^{\circ}\text{C}$	-0.5		+0.5	% $V_1\ nom$
$V_1\ nom$	Nominal Output Voltage	Refer to ordering information table as above				VDC
$V_1\ total\ reg$	Total Regulation	$V_{in\ min}$ to $V_{in\ max}$, 0 to 100% $I_{1\ nom}$, $T_{amb\ min}$ to $T_{amb\ max}$	-2		+2	% $V_1\ nom$
V_{adj}	Voltage Adjustment	V_1 output voltage could be adjusted with the potentiometer or I2C protocol		+/-10		% $V_1\ nom$
$V_1\ pp$	Output Ripple Voltage	$V_1\ nom$, $I_{1\ nom}$, 20 MHz BW #1			1	% $V_1\ nom$
$V_1\ Load\ reg$	Load Regulation	$V_i = V_1\ nom$, 0...100% $I_{1\ nom}$			2	% $V_1\ nom$
$V_1\ Line\ reg$	Line Regulation	$V_i = V_{i\ min} \dots V_{i\ max}$			1	% $V_1\ nom$
I_{share}	Current Sharing abs ($I_1 - I_2$), between any two units in parallel)	when Bus load $\geq 25\%$ of full load			2.5	A
		when Bus load $< 25\%$ of full load #2			3.5	A
$V_1\ dyn$	Dynamic Load Regulation	50 to 100% of load change, 50 Hz, 50% duty cycle, 1 A/us	-5		+5	% $V_1\ nom$
$T_{V1\ rec}$	Recovery Time			0.5	5	mS
$V_1\ Overshoot$	V_1 overshoot at turn-on				1	%
$C_{V1\ Load}$	Capacitive Loading	$T_{amb} = 25^{\circ}\text{C}$, $C_{Load} = 220\ \mu\text{F}/A \cdot I_{1\ nom}$				μF
Standby Output V_{sb}						
$V_{sb\ nom}$	Nominal Output Voltage			5		VDC
$V_{sb\ total\ reg}$	Total Regulation	$V_{sb\ min}$ to $V_{sb\ max}$, 0 to 100% $I_{sb\ nom}$, $T_{amb\ min}$ to $T_{amb\ max}$	-2		+2	% V_{sb}
$P_{sb\ nom}$	Nominal Output Power	$V_{sb} = 5$ VDC		5		W
$V_{sb\ pp}$	Output Ripple Voltage	$V_{sb\ nom}$, $I_{sb\ nom}$, 20 MHz BW			100	mV
$V_{sb\ Load\ reg}$	Load Regulation	$V_{sb} = V_{sb\ nom}$, 0...100% $I_{sb\ nom}$			2	% V_{sb}
$V_{sb\ Line\ reg}$	Line Regulation	$V_{sb} = V_{sb\ min} \dots V_{sb\ max}$			2	% V_{sb}
$I_{sb\ max}$	Current Limitation	Constant current limit then hiccup	120		150	% I_{sb}
$V_{sb\ dyn}$	Dynamic Load Regulation	50 to 100% of load change, 50 Hz, 50% duty cycle, 1 A/us	-5		+5	% V_{sb}
$T_{sb\ rec}$	Recovery Time			0.5	5	mS
$C_{sb\ Load}$	Capacitive Loading	$T_{amb} = 25^{\circ}\text{C}$			220	μF

+1.866.513.2839

tech.support@psbel.com

belpowersolutions.com

MBC600 Series

Fan Output V_{fan}				
$V_{fan\ nom}$	Nominal Output Voltage		12	VDC
$V_{fan\ total\ reg}$	Total Regulation	$V_{fan\ min}$ to $V_{fan\ max}$, 0 to 100% $I_{1\ nom}$, T_{amb} min to $T_{amb\ max}$	-20	+20 % $V_{fan\ nom}$
$P_{fan\ nom}$	Nominal Output Power	$V_{fan} = 12\ VDC$, Power derating linearly to 50% at 70°C, refer to figure 2	12	W
$V_{fan\ pp}$	Output Ripple Voltage	$V_{fan\ nom}$, $I_{fan\ nom}$, 20 MHz BW	2	% $V_{fan\ nom}$
$I_{fan\ max}$	Current Limitation	$T_{amb} = 25^\circ C$	270	% $I_{fan\ nom}$
$V_{fan\ dyn}$	Dynamic Load Regulation	50 to 100% of load change, 50 Hz, 50% duty cycle, 1 A/us	-5	+5 % $V_{fan\ nom}$
$T_{fan\ rec}$	Recovery Time		0.5	5 mS
$C_{fan\ Load}$	Capacitive Loading	$T_{amb} = 25^\circ C$	220	μF

NOTES:

- The output noise and ripple measurement was made with 20 MHz bandwidth using a 6 inch twisted pair, terminated with a 10 uF tantalum capacitor in parallel with a 0.1 uF ceramic capacitor.
- For MBC600-1048G, the current share abs (I1-I2) should be less than 3 A at light load (< 25% of full load)

Figure 2 - Output Power vs. Temperature

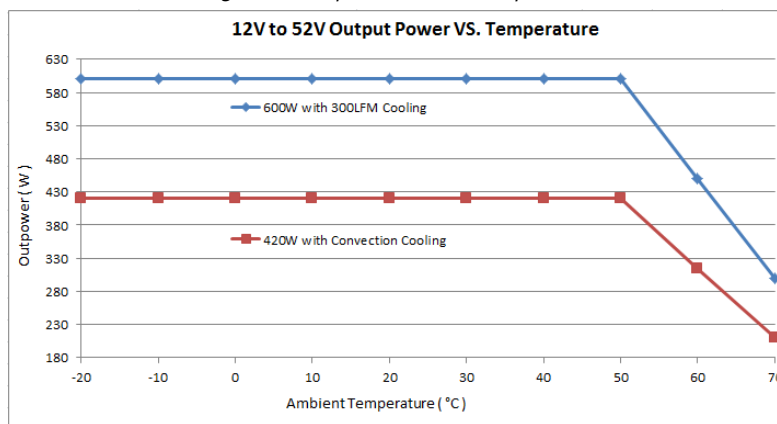

NOTE: Power derating linearly to 50% at 70°C for the output including main output V1, V_{fan} .

5 Protection

PARAMETER	DESCRIPTION / CONDITION	MIN	NOM	MAX	UNIT
F	Input Fuses (L+N)	Not user accessible, slow-acting (F)		10	A
$V_{in\ ov}$	Input Over Voltage Limit	285VAC/245VDC	/	295VAC/255VDC	V
	Recovery	280VAC/240VDC	/	290VAC/250VDC	V
$V_{in\ uv}$	Input Under Voltage Limit	75VAC/105VDC	/	85VAC/115VDC	V
	Recovery	80VAC/110VDC	/	90VAC/120VDC	V
$V_{1\ ov}$	OV Threshold V_1	110		132	% $V_{1\ nom}$
$V_{sb\ ov}$	OV Threshold V_{sb}	110		120	% $V_{sb\ nom}$
$I_{1\ lim}$	Current Limit V_1	Over current limit meet below curve, Figure 3			
$I_{sb\ lim}$	Current Limit V_{sb}	1.2		2	A
$I_{fan\ lim}$	Current Limit V_{fan}	$T_{amb} = 25^\circ C$		2.7	A
T_{SD}	Over Temperature On Heat Sinks	No damage, Automatic shut-down and recovers.			

The Output is protected against an overload or a Short Circuit for indefinite duration. The unit shall meet this requirement when in general operating conditions. Over current limit should meet below curve within +/-1.5 A tolerance, and the unit is allowed to hiccup under over current conditions.

+1.866.513.2839

tech.support@psbel.com

belpowersolutions.com

MBC600 Series

Figure 3 - Over Current Mode

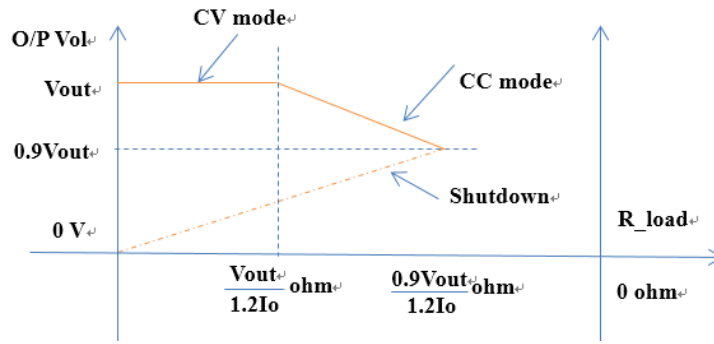

6 Graphical User Interface

Bel Power Solutions provides with its “Bel Power Solutions I²C Utility” a Windows® XP/Vista/Win7 compatible graphical user interface allowing the programming and monitoring of the MBC600 Series Front-End. The utility can be downloaded on www.belpowersolutions.com and supports both the PSMI and PMBus™ protocols.

The GUI allows automatic discovery of the units connected to the communication bus and will show them in the navigation tree. In the monitoring view the power supply can be controlled and monitored.

Reference Documents:

- BCA.00029_AA_ABC600 Series PMBus Communication Manual.pdf
- PMBus Specification Part I Revision 1.1
- PMBus Specification Part II Revision 1.1
- System Management Bus (SMBus) Specification Revision 2.0

Figure 4 - I²C Bus to DSP

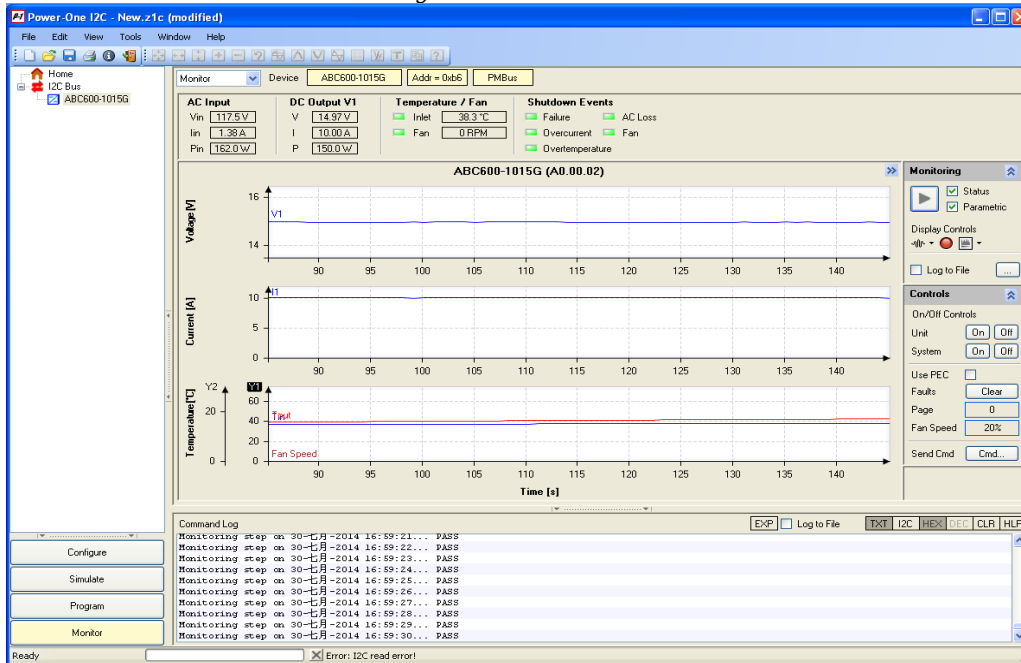

The sensor commands shall meet the following accuracy requirements.

MBC600 Series

COMMAND	10%-20% OF MAX LOAD	20%-100% OF MAX LOAD	REMARK
READ_IIN	< 0.5A	+/-20%	It is for corresponding to max input current
READ_IOUT	+/-5%	+/-2.5 A	It is for corresponding to max output current
READ_VIN	+/-3%	+/-2.5 V	It is for corresponding to max input voltage
READ_VOUT	+/-2%	+/-2%	
READ_PIN	- - -	+/-20%	It is for corresponding to max input power
READ_POUT	+/-5 %	+/-5%	It is for corresponding to max output power

7 Timing Diagram and Signals

Unless defined otherwise, all control signals shall be TTL compatible with respect to the output return and shall be isolated from the primary circuit and be SELV rated. All input signals shall be driven from an open collector with the pull-up resistor located in the power supply and shall be capable of sourcing up to 4 mA. Unless otherwise specified, signal levels for parameters listed in the table below are general LVTTTL signals.

PARAMETER	DESCRIPTION/CONDITION
A0, A1	PMBus selected address Pin.
SDA, SCL	SDA is serial data signal and SCL is serial clock signal (I ² C).
SMB_ALERT_L	Output alert signal. It shall be an open collector with the pull-up resistor located at the receiving end. This signal will be asserted due to fault or warning events. High = Normal, Low = Alert, Refer to Figure 5.
V _I _I _{share}	Current share signal. The PSU can operate at redundant mode by connecting V1_Ishare signal of each power supply together.
V _I _VS_SENSE, V _I _VS_SENSE_RTN	Remote Sense signal for V1, V1_VS_SENSE is positive sense, V1_VS_SENSE_RTN is negative sense.
V _{sb} , SGND	V _{sb} is standby output, and SGND is secondary ground.
+VP	Source voltage located at receiving end. Provide a voltage for power good signal. Refer to Figure 6.
PW_OK_H	Output power good signal. It is isolated from the output. Goes high/low when output is within regulation. Refer to Figure 6 (two methods for Power Good connection).
INHIBIT_L, INHIBIT_L_RTN	Power up signal. It is isolated from the output. Apply a DC voltage between INHIBIT_L and INHIBIT_L_RTN can power up the unit. Refer to Figure 6.
V _{fan} , SGND	V _{fan} is fan output to provide energy for user, and SGND is secondary ground.

Figure 5 - SMB_ALERT_L Connections

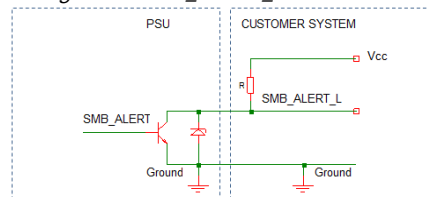

MBC600 Series

Figure 6 - Isolated Signal Output Connections

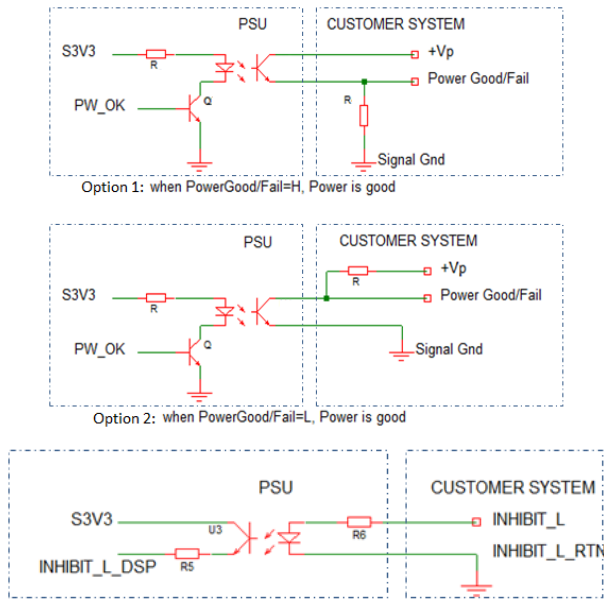

Low-Voltage TTL (LVTTTL) Voltage Levels

PARAMETER	SYMBOL	MIN	MAX	UNIT
Output High Voltage	V_{oh}	2.4	3.6	V
Output Low Voltage	V_{ol}	0	0.4	V
Input High Voltage	V_{ih}	2.0	3.6	V
Input Low Voltage	V_{il}	0	0.8	V
Sink current(PW_OK_H)	I_{sink}		4	mA
Operate voltage (between INHIBIT_L and INHIBIT_L_RTN)	V_{ope}	2.0	10	V
Max operate current (SMB_ALERT_L)	I_{ope}		30	mA

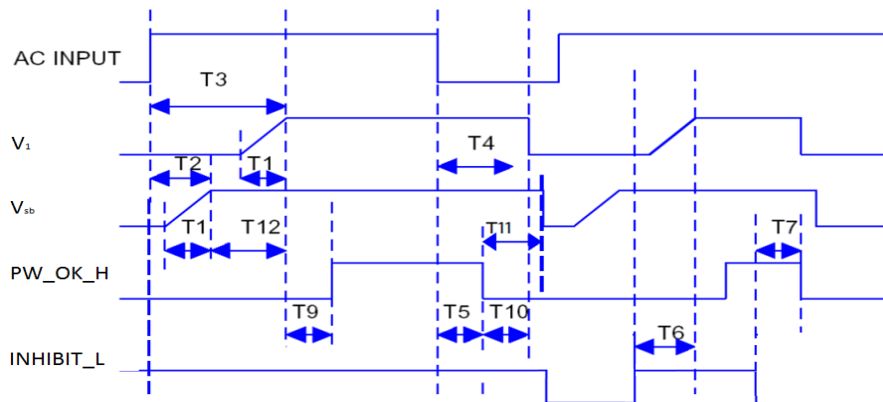

+1.866.513.2839
 tech.support@psbel.com
 belpowersolutions.com

MBC600 Series

PARAMETER	CONDITION/COMMENTS	MIN	NOM	MAX	UNIT
T1 (TV _{out_rise})	Output voltage rise time from each output	0.5		100	mS
T2 (TVAC _{on_Vsb})	Delay from AC being applied to V _{sb} being within regulation			2500	mS
T3 (TVAC _{on_V1})	Delay from AC being applied to V1 being within regulation			3000	mS
T4 (TV _{1_holdup})	Time V1 stay within 90% normal output after loss of AC	16			mS
T5 (T _{pwok_holdup})	Delay from loss of AC to de-assertion of PW_OK_H	10			mS
T6 (TinhibitH_V1 _{on})	Delay INHIBIT_L active to V1 output voltages within regulation			1000	mS
T7 (TinhibitL_pwok)	Delay from INHIBIT_L de-active to PW_OK_H being de-asserted			50	mS
T9 (TV _{1on_pwok})	Delay from V1 within regulation to PW_OK_H asserted at turn on	100		1000	mS
T10 (T _{pwok_off_V1})	Delay from PW_OK_H de-asserted to V1 dropping out of regulation at 60% loading of full load	1			mS
T11 (T _{pwok_off_Vsb})	Delay from PW_OK_H de-asserted to V _{sb} dropping out of regulation	20			mS
T12 (TV _{sb_V1})	Delay from V _{sb} being in regulation to V1 being in regulation at AC turn on	50		1000	mS

8 Environmental

PARAMETER	DESCRIPTION/CONDITION	CRITERION
Operating Temperature	See derating charts above Figure 2, T _{amb min} = - 25°C, T _{amb max} = 70°C	- 25 to 70°C
Storage Temperature		- 40 to 85°C
Relative Humidity	Operating humidity: Non-operating humidity, non-condensing	5%-90% 5%-95%
Altitude	Operating: Non-operating:	10,000 ft. 40,000 ft.
CE Mark	Complies with LVD Directive	
Conducted Emissions:	EN55022-B, CISPR22-B, FCC PART15-B	Criterion B
Static Discharge	EN61000-4-2, Level-3	Criterion A
RF Field Susceptibility	EN61000-4-3, Level-3	Criterion A
Fast Transients/Bursts	EN61000-4-4, Level-3	Criterion B
Radiated Emissions	EN55022-B, CISPR22-B, FCC PART15-B	Criterion B
Surge Susceptibility	EN61000-4-5, Level-3	Criterion B
RF Immunity	EN61000-4-6, Level-3	Criterion A
Magnetic Fields	EN61000-4-8, Level-4	Criterion A
Voltage Interruptions	EN61000-4-11	Criterion B
Harmonic Current	EN61000-3-2, Level A	Criterion A
Voltage Fluctuations / Flicker	EN61000-3-3	
Vibration	Operating: Random vibration; 5 to 500 Hz (10 minutes, each axis). Non-Operating: Random vibration; 5 to 500 Hz (10 minutes, each axis).	Max. 2.4Grms Max. 6Grms
Shock	Operating: half-sine, 11 ± 3 mS, 3-axis. Non-Operating: half-sine, 11 ± 3 mS, 3-axis.	Max. 15G Max. 40G

+1.866.513.2839

tech.support@psbel.com

belpowersolutions.com

MBC600 Series

9 Safety/Approvals

Maximum electric strength testing is performed according to IEC/EN 60601, ES/CSA60601-1. Input-to-output electric strength tests should not be repeated in the field. Bel Power Solutions will not honor any warranty claims resulting from electric strength field tests.

PARAMETER	DESCRIPTION / CONDITION	CRITERION
Agency Approvals	IEC 60601-1, EN 60601-1, CAN/CSA C22.2 No. 60601-1, ANSI/AAMI ES60601-1 2 X MOPP	Approved by independent body (see CE Declaration)
Isolation Strength	Input (L/N) to case (PE) Input (L/N) to output Output to case (PE)	Basic Reinforced Functional
Creepage / Clearance	Primary (L/N) to protective earth (PE) Primary to secondary	Min 4.0/2.5 mm Min 8/5 mm
Electrical Strength Test	Input to case Input to output Output and Signals to case	1781/2519 VAC/VDC 4607/6516 VAC/VDC 500 VDC

10 Mechanical

PARAMETER	CONDITIONS/DESCRIPTION
Dimensions (L x W x H)	203.2 x 127 x 40.64 mm
Mounting	(Location/Hardware); Dimensions Drawing Figure 7
Input	Connector type: Molex 26-62-4056 or equivalent; (J101); Figure 7
Output	Connector type: M4 screw terminal; (J106/107); Figure 7
Signal	Connector type: AMTEK 2211MS-208GW-U; (J102); Figure 7
Outline Drawing Pins/Functions	See Mechanical Drawing/ Figure 7
Weight	0.9 kg
Mounting distance	Distance from top of the components (component side) to the customer's metal chassis – Natural cooling: 101.6 mm Distance from top of the components (component side) to the customer's metal chassis – Force cooling: 5 mm ¹

¹ 5 mm is not required if there is insulator between PSU and customer chassis.

CONNECTOR	PIN DESCRIPTION	HOUSING	CRIMP TERMINAL	WIRE GAUGE
J101	J101-1 = Live J101-2 = Live J101-3 = not fitted J101-4 = Neutral J101-5 = Neutral	Molex 09-50-3051 or equivalent	Molex 08-50-0105 or equivalent	AWG#18~16
J102	J102-1: A0 J102-2: A1 J102-3: SDA J102-4: SCL J102-5: SMB_ALERT_L J102-6: V1_Ishare J102-7: V1_VS_SENSE J102-8: V1_VS_SENSE_RTN J102-9: SGND J102-10: Vsb J102-11: +VP J102-12: PW_OK_H J102-13: INHIBIT_L J102-14: INHIBIT_L_RTN J102-15: Vfan J102-16: SGND	JST PHDR-16VS or equivalent	JST SPHD-001T-P0.5 or equivalent	AWG#22~26
J103	J103: EARTH	NA	Molex 19002-0024 or equivalent	AWG#16
Output terminal J106/J107	J107 = V1_VS_RTN J106 = V1_VS	NA	Molex 0190670067 or equivalent	AWG#6

+1.866.513.2839

tech.support@psbel.com

belpowersolutions.com

MBC600 Series

11 Accessories

ITEM	DESCRIPTION	ORDERING PART NUMBER	SOURCE
	I²C Utility Windows XP/Vista/7 compatible GUI to program, control and monitor PET Front-Ends (and other I ² C units)	N/A	www.belpowersolutions.com

Figure 7 - Dimensions Drawing



For more information on these products consult: tech.support@psbel.com

NUCLEAR AND MEDICAL APPLICATIONS - Products are not designed or intended for use as critical components in life support systems, equipment used in hazardous environments, or nuclear control systems.

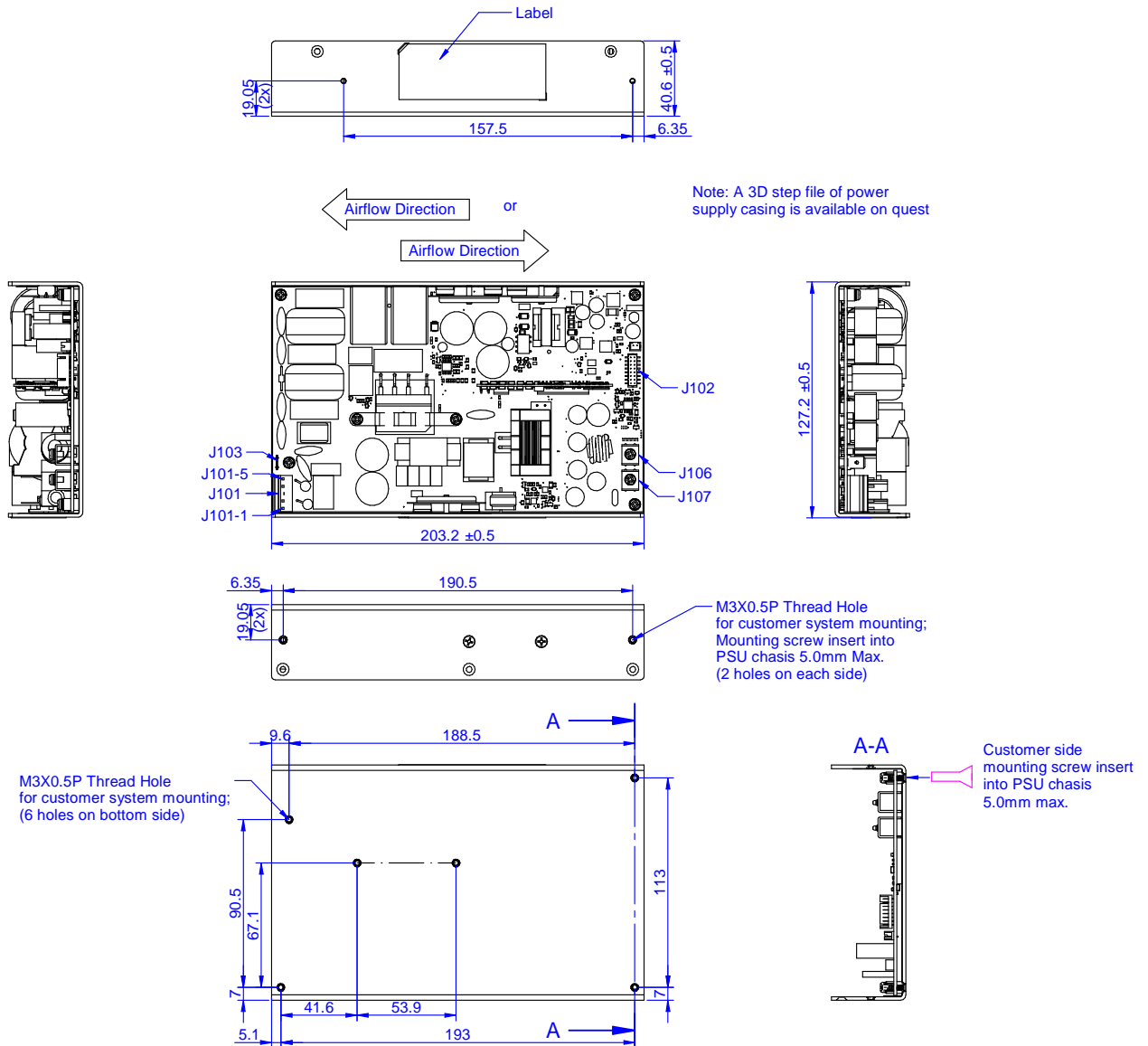
TECHNICAL REVISIONS - The appearance of products, including safety agency certifications pictured on labels, may change depending on the date manufactured. Specifications are subject to change without notice.

+1.866.513.2839

tech.support@psbel.com
belpowersolutions.com

Компания «Океан Электроники» предлагает заключение долгосрочных отношений при поставках импортных электронных компонентов на взаимовыгодных условиях!

Наши преимущества:

- Поставка оригинальных импортных электронных компонентов напрямую с производств Америки, Европы и Азии, а так же с крупнейших складов мира;
- Широкая линейка поставок активных и пассивных импортных электронных компонентов (более 30 млн. наименований);
- Поставка сложных, дефицитных, либо снятых с производства позиций;
- Оперативные сроки поставки под заказ (от 5 рабочих дней);
- Экспресс доставка в любую точку России;
- Помощь Конструкторского Отдела и консультации квалифицированных инженеров;
- Техническая поддержка проекта, помощь в подборе аналогов, поставка прототипов;
- Поставка электронных компонентов под контролем ВП;
- Система менеджмента качества сертифицирована по Международному стандарту ISO 9001;
- При необходимости вся продукция военного и аэрокосмического назначения проходит испытания и сертификацию в лаборатории (по согласованию с заказчиком);
- Поставка специализированных компонентов военного и аэрокосмического уровня качества (Xilinx, Altera, Analog Devices, Intersil, Interpoint, Microsemi, Actel, Aeroflex, Peregrine, VPT, Syfer, Eurofarad, Texas Instruments, MS Kennedy, Miteq, Cobham, E2V, MA-COM, Hittite, Mini-Circuits, General Dynamics и др.);

Компания «Океан Электроники» является официальным дистрибьютором и эксклюзивным представителем в России одного из крупнейших производителей разъемов военного и аэрокосмического назначения «JONHON», а так же официальным дистрибьютором и эксклюзивным представителем в России производителя высокотехнологичных и надежных решений для передачи СВЧ сигналов «FORSTAR».



JONHON

«JONHON» (основан в 1970 г.)

Разъемы специального, военного и аэрокосмического назначения:

(Применяются в военной, авиационной, аэрокосмической, морской, железнодорожной, горно- и нефтедобывающей отраслях промышленности)

«FORSTAR» (основан в 1998 г.)

ВЧ соединители, коаксиальные кабели, кабельные сборки и микроволновые компоненты:

(Применяются в телекоммуникациях гражданского и специального назначения, в средствах связи, РЛС, а так же военной, авиационной и аэрокосмической отраслях промышленности).



Телефон: 8 (812) 309-75-97 (многоканальный)

Факс: 8 (812) 320-03-32

Электронная почта: ocean@oceanchips.ru

Web: <http://oceanchips.ru/>

Адрес: 198099, г. Санкт-Петербург, ул. Калинина, д. 2, корп. 4, лит. А