



## Honeywell Hawk™ Resolvers

---

### 1-Inch Series, Fully-Housed Configuration

#### DESCRIPTION

Resolvers convert mechanical shaft position to an electrical signal which represents the actual shaft angle. They are variable transformers in which the stator has two phase windings mechanically displaced by 90°. The output consists of two sine waves that are phase shifted by 90°. They provide non-contact measurement for 360° sensing, enhanced accuracy, resolution, and repeatability under severe environmental conditions.

Resolvers are generally chosen over electronic sensors (i.e., optical encoders, potentiometers, magnetic encoders/sensors) because they do not use electronics, so they are not susceptible to performance fluctuations in harsh environments. Resolvers are inherently radiation hardened and offer durable EMC (Electromagnetic Compatibility) performance.

**Honeywell's Hawk™ 1-Inch Series Resolvers** are durable, reliable, non-contact, absolute position sensors with an operating temperature range from -50.8 °C to 93.3 °C [-60 °F to 200 °F] that allows for potential use in defense and aerospace applications.

#### Manufacturing Process Reduces Lead Time and Allows Customization

Honeywell uses the same components for all standard configurations of its Hawk™ 1-Inch Series Resolvers, increasing production speed and reducing lead time. This

results in Honeywell's ability to manufacture production-quality standard devices in 12 weeks versus 20-22 weeks many competitors offer. Additionally, Honeywell's manufacturing process and the variety of product features allow customers to customize the resolver to meet their specific application accuracy and size requirements.

#### Global Support and Engineering Expertise

Honeywell's global presence offers customers timely product and application support. Many resolver competitors offer support only in their local manufacturing area, or limited support outside of their manufacturing area.

With over 30 years of experience providing accurate, reliable, and durable resolvers for the aerospace and defense industries, Honeywell is your one-stop, full-service, globally-competitive answer to your resolver needs.

#### Options

- Custom trim
- Connections include custom lead wire, cable, connector on unit or connector on cable
- Custom redundant brushless version (two independent resolvers within the same housing) to provide reliable back-up/fail-safe in critical applications
- Titanium housing provides enhanced durability and enhanced resistance to corrosion; lightweight
- Transformer for 360°+ rotation (continuous)

# Honeywell Hawk™ Resolvers

## VALUE PROPOSITIONS (★ = competitive differentiator)

---

- ★ **Shock** specification of 50 g, 11 ms allows for use in harsh military and aerospace applications
- ★ **Vibration** specification of 15 g, 10 Hz to 2000 Hz allows for use in harsh military and aerospace applications
- ★ **Enhanced reliability and durability** when compared with potentiometers due to the Hawk™ Resolvers' ability to resolve an absolute angle using magnetic principles so that performance is not impacted by media (i.e., sand, dust, water), its ability to operate in many harsh environments, its non-contact design, the lack of electronics, and the use of space-qualified materials
- ★ **Operating temperature range** of -50.8 °C to 93.3 °C [-60 °F to 200 °F] allows for use in harsh environments and meets standard military and space application requirements
- ★ **Excitation voltage range** of 2 V to 15 V allows customers to standardize on a resolver that meets their excitation voltage needs, simplifying sourcing and delivery, and saving time
- ★ **Product delivery up to 1.5 times faster** than many competitive products due to Honeywell's use of the same components for all standard configurations of Hawk™ Resolvers, increasing production speed and reducing lead time. This results in Honeywell's ability to manufacture production-quality standard devices in 12 weeks vs. 20-22 weeks
- ★ **Customization** due to Honeywell's manufacturing process and the variety of features that allow customers to customize Hawk™ Resolvers to meet their application accuracy/size requirements
- ★ **Global support** due to Honeywell's worldwide presence which offers customers immediate product and application support; many resolver competitors offer either support only in their local manufacturing area, or limited support outside of their manufacturing area
- ★ **Engineering expertise** due to Honeywell's 30+ years' experience providing accurate, reliable, and durable resolvers for the aerospace and defense industries

## FEATURES AND BENEFITS (in addition to value propositions)

---

- **Fully housed configuration** with bearing/shaft
- **Small outer diameter** of 1 inch allows for use in size-restricted applications
- **Single speed operation** (1 magnetic pole pair) allows for cost-effective angle resolution over a 360°+ range
- **Excitation frequency range** of 2000 Hz to 5000 Hz provides a wide variety of choices with which to power the device

- **Transformation ratio** of 0.45 or 1.0 offers customers two choices, increasing flexibility within the application
- **Accuracy** of ±420 arcsec enables precise motion control of weapon systems and space positioning devices
- **Non-contact magnetic technology** eliminates mechanical contact, reducing wear and improving reliability and durability by enhancing operation in harsh environments (performance is not affected by sand, dust or water)
- **Meets multiple military/aerospace specifications:** DO-160D, MIL-STD-202G, MIL-STD-810G, MIL-STD-81963B, MIL-STD-461F; complies with space outgassing requirement SP-R0022

## POTENTIAL APPLICATIONS

---

### Defense

- **Electro-optical systems (i.e., systems that transfer information from the optical system to the firing mechanism):** Provides absolute position feedback of the azimuth and/or elevation angular planes for precise ordnance delivery
- **Fire control systems (i.e., weapon systems on military vehicles or vessels):** Provides absolute position feedback of the azimuth and/or elevation angular planes for precise ordnance delivery
- **Gimbals position feedback (i.e., communication pedestals positioned on top of military vehicles):** Provides absolute position feedback of the azimuth and/or elevation angular planes for a continuous communication stream
- **Infrared systems (i.e., military vehicle infrared systems):** Accurately aims the infrared system at the target

### Aerospace

- **Space vehicle solar panels:** Accurately positions the equipment for maximum performance
- **Space vehicle antennae:** Accurately positions the equipment for maximum performance

### Medical

- **Oncology equipment:** Provides precision feedback of oncology systems to assist in positioning during examinations

### Industrial

- **CNC/precision tooling:** Provides angular position feedback of attachments

# 1-Inch Series, Fully-Housed Configuration

**Table 1. Operating Characteristics (At 25 °C [77 °F].)**

Characteristic	Parameter
Speed	1X
Excitation voltage range	2 V to 15 V
Excitation frequency range	2000 Hz to 5000 Hz
Input current	160 mA max.
Input power	1.30 W max.
Electrical load	30 kOhm min.
Phase shift	40° max.
Accuracy	±420 arcsec
Angular range	360°+
Transformation ratio	0.45 or 1.0
Operating temp. range	-50.8 °C to 93.3 °C [-60 °F to 200 °F]

**Table 2. Mechanical Characteristics (At 25 °C [77 °F].)**

Characteristic	Parameter
Mounting concentricity	<0.0005 in
Primary winding	rotor
Friction torque	≤0.5 oz in
Shaft runout	≤0.0015 TIR <sup>1</sup>
Shaft radial play	≤0.0006 in with 4 oz load
Shaft end play	≤0.0005 in with 8 oz load
Weight	<5 oz

**Note 1:** TIR stands for Total Indicator Runout.

**Table 3. Environmental Characteristics**

Characteristic	Parameter
Vibration	MIL-S-81963B, Section 3.7.1, 15 g, 10 Hz to 2000 Hz, 4 hr each on 3 axes
Shock	MIL-S-81963B, Section 3.7.2, 50 g, 11 ms duration, 3 axes, 2 directions, 5 impacts each axis/direction, 30 total
Storage temp.	MIL-STD-810G, 501.5 and 502.5, -50.8 °C to 93.3 °C
Humidity cycle	MIL-STD-202 G Condition 106
Thermal cycle	RTCA/DO-160D Section 5, -50.8 °C to 93.3 °C extreme temperatures, 10 °C per minute transition
Sealing	IP64 NEMA
EMC	MIL-STD-461 RS-101, RE-101, RE-102
Outgassing	SP-R0022 (NASA outgassing requirements)
Endurance	MIL-hdbk-218 (6.2): 1200 hr at 1150 rpm
Material:	
housing	416 stainless steel
shaft	303 stainless steel

# Honeywell Hawk™ Resolvers

Figure 1. Electrical Schematic (Positive Direction of Rotation Clockwise, Viewed from Shaft End)

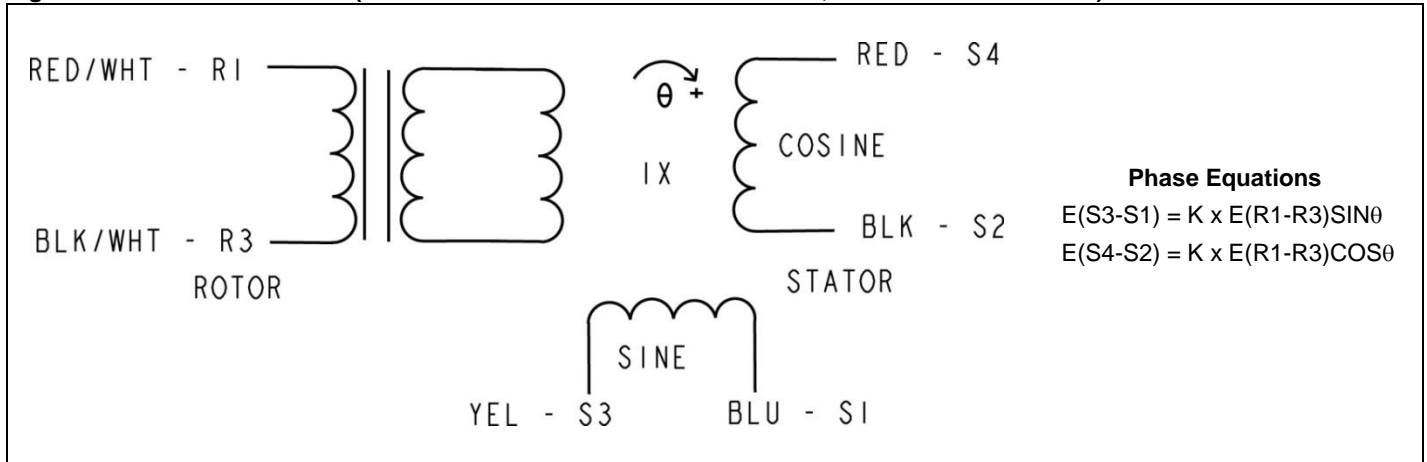
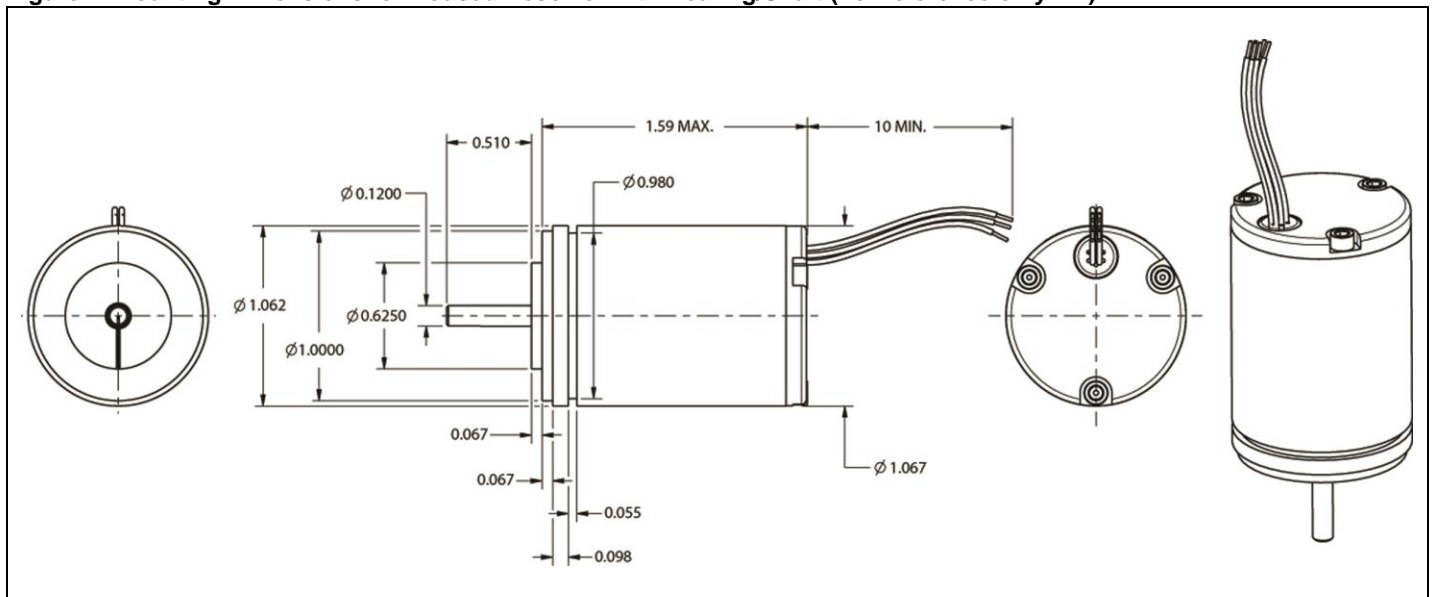

Figure 2. Mounting Dimensions for Housed Resolver with Bearing/Shaft (For reference only. in.)<sup>1</sup>



**Note1:** Shaft OD is fully housed with bearings unit; may be customer specified

Table 4. Order Guide

Catalog Listing	Description
S10H01XHAGNYG	Honeywell Hawk™ 1-Inch Series Resolvers, single speed, 1.0 in outside diameter, fully housed with transformer, 0.1 in inside diameter, 7 V, 5000 Hz, leadwire, series 11 NEMA servo-mount enclosure, no bolt pattern, 1.0 transformation ratio, ±420 arcsec accuracy, stainless steel housing
S10H01XHAGNXG	Honeywell Hawk™ 1-Inch Series Resolvers, single speed, 1.0 in outside diameter, fully housed with transformer, redundant, 0.1 in inside diameter, 7 V, 5000 Hz, leadwire, series 11 NEMA servo-mount enclosure, no bolt pattern, 0.45 transformation ratio, ±420 arcsec accuracy, stainless steel housing

# 1-Inch Series, Fully-Housed Configuration

## **WARNING**

### **PERSONAL INJURY**

DO NOT USE these products as safety or emergency stop devices or in any other application where failure of the product could result in personal injury.

**Failure to comply with these instructions could result in death or serious injury.**

### **WARRANTY/REMEDY**

Honeywell warrants goods of its manufacture as being free of defective materials and faulty workmanship. Honeywell's standard product warranty applies unless agreed to otherwise by Honeywell in writing; please refer to your order acknowledgement or consult your local sales office for specific warranty details. If warranted goods are returned to Honeywell during the period of coverage, Honeywell will repair or replace, at its option, without charge those items it finds defective. **The foregoing is buyer's sole remedy and is in lieu of all other warranties, expressed or implied, including those of merchantability and fitness for a particular purpose. In no event shall Honeywell be liable for consequential, special, or indirect damages.**

While we provide application assistance personally, through our literature and the Honeywell web site, it is up to the customer to determine the suitability of the product in the application.

Specifications may change without notice. The information we supply is believed to be accurate and reliable as of this printing. However, we assume no responsibility for its use.

## **WARNING**

### **MISUSE OF DOCUMENTATION**

- The information presented in this product sheet is for reference only. Do not use this document as a product installation guide.
- Complete installation, operation, and maintenance information is provided in the instructions supplied with each product.

**Failure to comply with these instructions could result in death or serious injury.**

### **FIND OUT MORE**

Honeywell serves its customers through a worldwide network of sales offices, representatives and distributors. For application assistance, current specifications, pricing or name of the nearest Authorized Distributor, contact your local sales office.

To learn more about Honeywell's sensing and control products, call **+1-815-235-6847** or **1-800-537-6945**, visit **[sensing.honeywell.com](http://sensing.honeywell.com)**, or e-mail inquiries to **[info.sc@honeywell.com](mailto:info.sc@honeywell.com)**

Компания «Океан Электроники» предлагает заключение долгосрочных отношений при поставках импортных электронных компонентов на взаимовыгодных условиях!

Наши преимущества:

- Поставка оригинальных импортных электронных компонентов напрямую с производств Америки, Европы и Азии, а так же с крупнейших складов мира;
- Широкая линейка поставок активных и пассивных импортных электронных компонентов (более 30 млн. наименований);
- Поставка сложных, дефицитных, либо снятых с производства позиций;
- Оперативные сроки поставки под заказ (от 5 рабочих дней);
- Экспресс доставка в любую точку России;
- Помощь Конструкторского Отдела и консультации квалифицированных инженеров;
- Техническая поддержка проекта, помощь в подборе аналогов, поставка прототипов;
- Поставка электронных компонентов под контролем ВП;
- Система менеджмента качества сертифицирована по Международному стандарту ISO 9001;
- При необходимости вся продукция военного и аэрокосмического назначения проходит испытания и сертификацию в лаборатории (по согласованию с заказчиком);
- Поставка специализированных компонентов военного и аэрокосмического уровня качества (Xilinx, Altera, Analog Devices, Intersil, Interpoint, Microsemi, Actel, Aeroflex, Peregrine, VPT, Syfer, Eurofarad, Texas Instruments, MS Kennedy, Miteq, Cobham, E2V, MA-COM, Hittite, Mini-Circuits, General Dynamics и др.);

Компания «Океан Электроники» является официальным дистрибьютором и эксклюзивным представителем в России одного из крупнейших производителей разъемов военного и аэрокосмического назначения «**JONHON**», а так же официальным дистрибьютором и эксклюзивным представителем в России производителя высокотехнологичных и надежных решений для передачи СВЧ сигналов «**FORSTAR**».



**JONHON**

«**JONHON**» (основан в 1970 г.)

Разъемы специального, военного и аэрокосмического назначения:

(Применяются в военной, авиационной, аэрокосмической, морской, железнодорожной, горно- и нефтедобывающей отраслях промышленности)

«**FORSTAR**» (основан в 1998 г.)

ВЧ соединители, коаксиальные кабели, кабельные сборки и микроволновые компоненты:

(Применяются в телекоммуникациях гражданского и специального назначения, в средствах связи, РЛС, а так же военной, авиационной и аэрокосмической отраслях промышленности).



Телефон: 8 (812) 309-75-97 (многоканальный)

Факс: 8 (812) 320-03-32

Электронная почта: [ocean@oceanchips.ru](mailto:ocean@oceanchips.ru)

Web: <http://oceanchips.ru/>

Адрес: 198099, г. Санкт-Петербург, ул. Калинина, д. 2, корп. 4, лит. А