



VNQ5050K-E

Quad channel high side driver for automotive applications

Features

Max supply voltage	V_{CC}	41 V
Operating voltage range	V_{CC}	4.5 to 36 V
Max on-state resistance (per ch.)	R_{ON}	50 m Ω
Current limitation (typ)	I_{LIMH}	19 A
Off-state supply current	I_S	2 $\mu A^{(1)}$

1. Typical value with all loads connected

■ General features

- Inrush current active management by power limitation
- Very low standby current
- 3.0 V CMOS compatible input
- Optimized electromagnetic emission
- Very low electromagnetic susceptibility
- In compliance with the 2002/95/EC European directive

■ Diagnostic functions

- Open drain status output
- On-state open load detection
- Off-state open load detection
- Thermal shutdown indication

■ Protection

- Undervoltage shutdown
- Overvoltage clamp
- Load current limitation
- Self limiting of fast thermal transients
- Protection against loss of ground and loss of V_{CC}
- Thermal shutdown
- Reverse battery protection (see [Application schematic on page 19](#))
- Electrostatic discharge protection



Applications

- All types of resistive, inductive and capacitive loads

Description

The VNQ5050K-E is a monolithic device made using STMicroelectronics VIPower M0-5 technology. It is intended for driving resistive or inductive loads with one side connected to ground. Active V_{CC} pin voltage clamp protects the device against low energy spikes (see ISO7637 transient compatibility table).

The device detects open load condition both in on and off-state, when STAT_DIS is left open or driven low. Output shorted to V_{CC} is detected in the off-state.

When STAT_DIS is driven high, the STATUS pin is in a high impedance condition.

Output current limitation protects the device in overload condition. In case of long overload duration, the device limits the dissipated power to a safe level up to thermal shutdown intervention. Thermal shutdown with automatic restart allows the device to recover normal operation as soon as the fault condition disappears.

Table 1. Device summary

Package	Order code	
	Tube	Tape and reel
PowerSSO-24	VNQ5050K-E	VNQ5050KTR-E

Contents

1	Block diagram and pin configuration	5
2	Electrical specifications	7
2.1	Absolute maximum ratings	7
2.2	Thermal data	8
2.3	Electrical characteristics	9
2.4	Electrical characteristics curves	15
3	Application information	19
3.1	GND protection network against reverse battery	19
3.1.1	Solution 1: resistor in the ground line (RGND only)	19
3.1.2	Solution 2: a diode (DGND) in the ground line	20
3.2	Load dump protection	20
3.3	Microprocessor I/Os protection	20
3.4	Open-load detection in off-state	20
3.5	Maximum demagnetization energy (VCC = 13.5V)	23
4	Package and PC board thermal data	24
4.1	PowerSSO-24 thermal data	24
5	Package and packing information	27
5.1	ECOPACK [®] packages	27
5.2	PowerSSO-24 [™] mechanical data	27
5.3	Packing information	29
6	Revision history	30

List of tables

Table 1.	Device summary	1
Table 2.	Pin functions	5
Table 3.	Suggested connections for unused and not connected pins	6
Table 4.	Absolute maximum ratings	7
Table 5.	Thermal data	8
Table 6.	Power section	9
Table 7.	Switching ($V_{CC}=13V$; $T_j=25^{\circ}C$)	9
Table 8.	Status pin ($V_{SD}=0$)	10
Table 9.	Protections	10
Table 10.	Open-load detection	10
Table 11.	Logic input	11
Table 12.	Truth table.	12
Table 13.	Electrical transient requirements (part 1/3)	13
Table 14.	Electrical transient requirements (part 2/3)	14
Table 15.	Electrical transient requirements (part 3/3)	14
Table 16.	Thermal parameters	26
Table 17.	PowerSSO-24™ mechanical data	28
Table 18.	Document revision history	30

List of figures

Figure 1.	Block diagram	5
Figure 2.	Configuration diagram (top view)	6
Figure 3.	Current and voltage conventions	7
Figure 4.	Status timings	12
Figure 5.	Output voltage drop limitation	12
Figure 6.	Switching characteristics	13
Figure 7.	Off-state output current	15
Figure 8.	High level input current	15
Figure 9.	Input clamp voltage	15
Figure 10.	Input low level	15
Figure 11.	Input high level	15
Figure 12.	Input hysteresis voltage	15
Figure 13.	On-state resistance vs T_{case}	16
Figure 14.	On-state resistance vs V_{CC}	16
Figure 15.	Undervoltage shutdown	16
Figure 16.	Turn-on voltage slope	16
Figure 17.	I_{LIMH} vs T_{case}	16
Figure 18.	Turn-off voltage slope	16
Figure 19.	Status low output voltage	17
Figure 20.	Status leakage current	17
Figure 21.	Status clamp voltage	17
Figure 22.	Open-load on-state detection threshold	17
Figure 23.	Open-load off-state voltage detection threshold	17
Figure 24.	STAT_DIS clamp voltage	17
Figure 25.	High level STAT_DIS voltage	18
Figure 26.	Low level STAT_DIS voltage	18
Figure 27.	Application schematic	19
Figure 28.	Open-load detection in off-state	21
Figure 29.	Waveforms	22
Figure 30.	Maximum turn-off current versus inductance (for each channel)	23
Figure 31.	PowerSSO-24 PC board	24
Figure 32.	$R_{thj-amb}$ vs PCB copper area in open box free air condition (one channel on)	24
Figure 33.	PowerSSO-24 thermal impedance junction ambient single pulse (one channel on)	25
Figure 34.	Thermal fitting model of a double channel HSD in PowerSSO-24	25
Figure 35.	PowerSSO-24™ package dimensions	27
Figure 36.	PowerSSO-24 tube shipment (no suffix)	29
Figure 37.	PowerSSO-24 tape and reel shipment (suffix "TR")	29

1 Block diagram and pin configuration

Figure 1. Block diagram

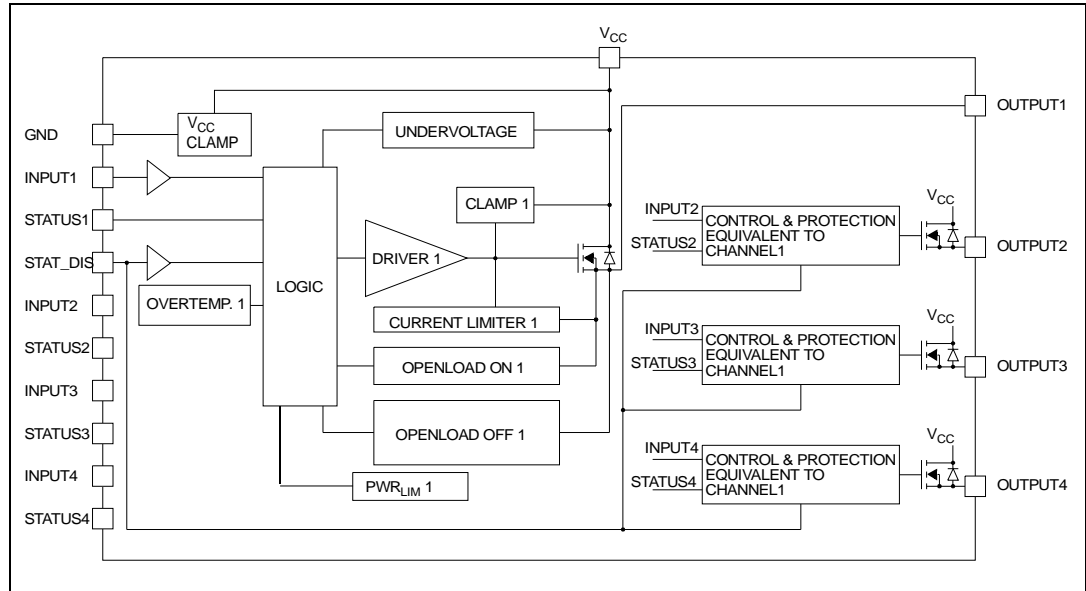

Table 2. Pin functions

Name	Function
V _{CC}	Battery connection
OUTPUTn	Power output
GND	Ground connection. Must be reverse battery protected by an external diode/resistor network
INPUTn	Voltage controlled input pin with hysteresis, CMOS compatible. Controls output switch state
STATUSn	Open drain digital diagnostic pin
STAT_DIS	Active high CMOS compatible pin, to disable the STATUS pin

Figure 2. Configuration diagram (top view)

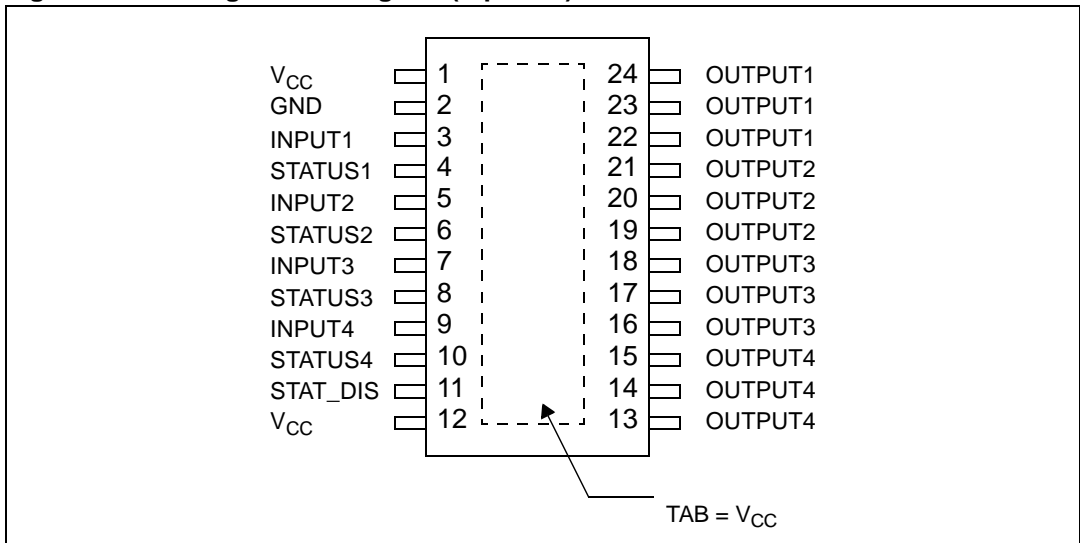

Table 3. Suggested connections for unused and not connected pins

Connection/pin	Status	N.C.	Output	Input	STAT_DIS
Floating	X	X	X	X	X
To ground	N.R. ⁽¹⁾	X	N.R.	Through 10 KΩ resistor	Through 10 KΩ resistor

1. Not recommended

2 Electrical specifications

Figure 3. Current and voltage conventions

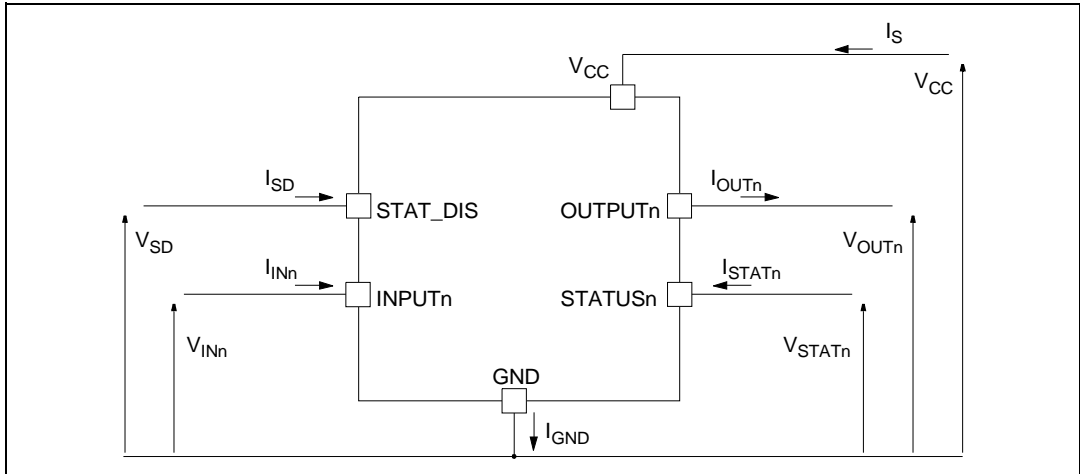

Note: $V_{Fn} = V_{OUTn} - V_{CC}$ during reverse battery condition

2.1 Absolute maximum ratings

Stressing the device above the ratings listed in the “Absolute maximum ratings” tables may cause permanent damage to the device. These are stress ratings only and operation of the device at these or any other conditions above those indicated in the Operating sections of this specification is not implied. Exposure to the conditions in this section for extended periods may affect device reliability. Refer also to the STMicroelectronics SURE Program and other relevant quality documents.

Table 4. Absolute maximum ratings

Symbol	Parameter	Value	Unit
V _{CC}	DC supply voltage	41	V
- V _{CC}	Reverse DC supply voltage	0.3	V
- I _{GND}	DC reverse ground pin current	200	mA
I _{OUT}	DC output current	Internally limited	A
- I _{OUT}	Reverse DC output current	15	A
I _{IN}	DC input current	+10/-1	mA
I _{STAT}	DC status current	+10/-1	mA
I _{STAT_DIS}	DC status disable current	+10 / -1	mA
E _{MAX}	Maximum switching energy (single pulse) (L=3 mH; R _L =0Ω; V _{bat} =13.5V; T _{jstart} =150°C; I _{OUT} = I _{limL} (typ.))	104	mJ

Table 4. Absolute maximum ratings (continued)

Symbol	Parameter	Value	Unit
V_{ESD}	Electrostatic discharge (human body model: R=1.5K Ω ; C=100pF)		
	– Input	4000	V
	– Status	4000	V
	– STAT_DIS	4000	V
	– Output	5000	V
	– V_{CC}	5000	V
V_{ESD}	Charge device model (CDM-AEC-Q100-011)	750	V
T_j	Junction operating temperature	-40 to 150	°C
T_{stg}	Storage temperature	- 55 to 150	°C

2.2 Thermal data

Table 5. Thermal data

Symbol	Parameter	Max value	Unit
$R_{thj-case}$	Thermal resistance junction-case (With one channel ON)	2.8	°C/W
$R_{thj-amb}$	Thermal resistance junction-ambient	See Figure 32 .	°C/W

2.3 Electrical characteristics

Values specified in this section are for $8\text{ V} < V_{CC} < 36\text{ V}$, $-40\text{ }^{\circ}\text{C} < T_j < 150\text{ }^{\circ}\text{C}$, unless otherwise stated.

Table 6. Power section

Symbol	Parameter	Test conditions	Min.	Typ.	Max.	Unit
V_{CC}	Operating supply voltage		4.5	13	36	V
V_{USD}	Undervoltage shutdown			3.5	4.5	V
$V_{USDhyst}$	Undervoltage shutdown hysteresis			0.5		V
R_{ON}	On-state resistance ⁽¹⁾	$I_{OUT}=2\text{A}$; $T_j=25^{\circ}\text{C}$ $I_{OUT}=2\text{A}$; $T_j=150^{\circ}\text{C}$ $I_{OUT}=2\text{A}$; $V_{CC}=5\text{V}$; $T_j=25^{\circ}\text{C}$			50 100 65	mΩ mΩ mΩ
V_{clamp}	Clamp Voltage	$I_S=20\text{ mA}$	41	46	52	V
I_S	Supply current	Off-state; $V_{CC}=13\text{V}$; $V_{IN}=V_{OUT}=0\text{V}$; $T_j=25^{\circ}\text{C}$ On-state; $V_{IN}=5\text{V}$; $V_{CC}=13\text{V}$; $I_{OUT}=0\text{A}$		2 ⁽²⁾ 8	5 ⁽²⁾ 14	μA mA
$I_{L(off1)}$	Off-state output current ⁽¹⁾	$V_{IN}=V_{OUT}=0\text{V}$; $V_{CC}=13\text{V}$; $T_j=25^{\circ}\text{C}$ $V_{IN}=V_{OUT}=0\text{V}$; $V_{CC}=13\text{V}$; $T_j=125^{\circ}\text{C}$	0 0	0.01	3 5	μA μA
$I_{L(off2)}$	Off-state output current ⁽¹⁾	$V_{IN}=0\text{V}$; $V_{OUT}=4\text{V}$	-75		0	μA
V_F	Output - V_{CC} diode voltage ⁽¹⁾	$-I_{OUT}=2\text{A}$; $T_j=150^{\circ}\text{C}$			0.7	V

1. For each channel.

2. PowerMOS leakage included

Table 7. Switching ($V_{CC}=13\text{V}$; $T_j=25^{\circ}\text{C}$)

Symbol	Parameter	Test conditions	Min.	Typ.	Max.	Unit
$t_{d(on)}$	Turn-on delay time	$R_L=6.5\Omega$ (see Figure 6)	-	15	-	μs
$t_{d(off)}$	Turn-off delay time	$R_L=6.5\Omega$ (see Figure 6)	-	40	-	μs
$dV_{OUT}/dt_{(on)}$	Turn-on voltage slope	$R_L=6.5\Omega$ (See Figure 16)	-		-	V/μs
$dV_{OUT}/dt_{(off)}$	Turn-off voltage slope	$R_L=6.5\Omega$ (See Figure 18)	-		-	V/μs
W_{ON}	Switching energy losses during t_{won}	$R_L=6.5\Omega$ (see Figure 6)	-	0.19	-	mJ
W_{OFF}	Switching energy losses during t_{woff}	$R_L=6.5\Omega$ (see Figure 6)	-	0.27	-	mJ

Table 8. Status pin ($V_{SD}=0$)

Symbol	Parameter	Test conditions	Min.	Typ.	Max.	Unit
V_{STAT}	Status low output voltage	$I_{STAT} = 1.6 \text{ mA}$, $V_{SD}=0\text{V}$			0.5	V
I_{LSTAT}	Status leakage current	Normal operation or $V_{SD}=5\text{V}$, $V_{STAT}=5\text{V}$			10	μA
C_{STAT}	Status pin input capacitance	Normal operation or $V_{SD}=5\text{V}$, $V_{STAT}=5\text{V}$			100	pF
V_{SCL}	Status clamp voltage	$I_{STAT} = 1\text{mA}$ $I_{STAT} = -1\text{mA}$	5.5	-0.7	7	V V

Table 9. Protections

Symbol	Parameter	Test conditions	Min.	Typ.	Max.	Unit
I_{limH}	DC short circuit current	$V_{CC}=13\text{V}$ $5\text{V} < V_{CC} < 36\text{V}$	13.5	19	26.5 26.5	A A
I_{limL}	Short circuit current during thermal cycling	$V_{CC}=13\text{V}$ $T_R < T_j < T_{TSD}$		7		A
T_{TSD}	Shutdown temperature		150	175	200	$^{\circ}\text{C}$
T_R	Reset temperature		$T_{RS} + 1$	$T_{RS} + 5$		$^{\circ}\text{C}$
T_{RS}	Thermal reset of STATUS		135			$^{\circ}\text{C}$
T_{HYST}	Thermal hysteresis ($T_{TSD} - T_R$)			7		$^{\circ}\text{C}$
t_{SDL}	Status delay in overload conditions	$T_j > T_{TSD}$ (See Figure 4)			20	μs
V_{DEMAG}	Turn-off output voltage clamp	$I_{OUT}=2\text{A}$; $V_{IN}=0$; $L=6\text{mH}$	$V_{CC}-41$	$V_{CC}-46$	$V_{CC}-52$	V
V_{ON}	Output voltage drop limitation	$I_{OUT}=0.1\text{A}$ (see Figure 5) $T_j = -40^{\circ}\text{C} \dots +150^{\circ}\text{C}$		25		mV

Note: To ensure long term reliability under heavy overload or short circuit conditions, protection and related diagnostic signals must be used together with a proper software strategy. If the device is subjected to abnormal conditions, this software must limit the duration and number of activation cycles

Table 10. Open-load detection

Symbol	Parameter	Test conditions	Min.	Typ.	Max.	Unit
I_{OL}	Open-load on-state detection threshold	$V_{IN} = 5\text{V}$, $8\text{V} < V_{CC} < 18\text{V}$ (See Figure 22.)	10		70	mA
$t_{DOL(on)}$	Open-load on-state detection delay	$I_{OUT} = 0\text{A}$, $V_{CC}=13\text{V}$ (See Figure 4.)			200	μs

Table 10. Open-load detection (continued)

Symbol	Parameter	Test conditions	Min.	Typ.	Max.	Unit
t_{POL}	Delay between input falling edge and status rising edge in open-load condition	$I_{OUT} = 0A$ (See Figure 4.)	200	500	1000	μs
V_{OL}	Open-load off-state voltage detection threshold	$V_{IN} = 0V, 8V < V_{CC} < 16V$ (See Figure 23.)	2		4	V
t_{DSTKON}	Output short circuit to V_{CC} detection delay at turn-off	(See Figure 4.)	180		t_{POL}	μs

Table 11. Logic input

Symbol	Parameter	Test conditions	Min.	Typ.	Max.	Unit
V_{IL}	Input low level				0.9	V
I_{IL}	Low level input current	$V_{IN} = 0.9V$	1			μA
V_{IH}	Input high level		2.1			V
I_{IH}	High level input current	$V_{IN} = 2.1V$			10	μA
$V_{I(hyst)}$	Input hysteresis voltage		0.25			V
V_{ICL}	Input clamp voltage	$I_{IN} = 1mA$ $I_{IN} = -1mA$	5.5	-0.7	7	V V
V_{SDL}	STAT_DIS low level voltage				0.9	V
I_{SDL}	Low level STAT_DIS current	$V_{SD} = 0.9V$	1			μA
V_{SDH}	STAT_DIS high level voltage		2.1			V
I_{SDH}	High level STAT_DIS current	$V_{SD} = 2.1V$			10	μA
$V_{SD(hyst)}$	STAT_DIS hysteresis voltage		0.25			V
V_{SDCL}	STAT_DIS clamp voltage	$I_{SD} = 1mA$ $I_{SD} = -1mA$	5.5	-0.7	7	V V

Figure 4. Status timings

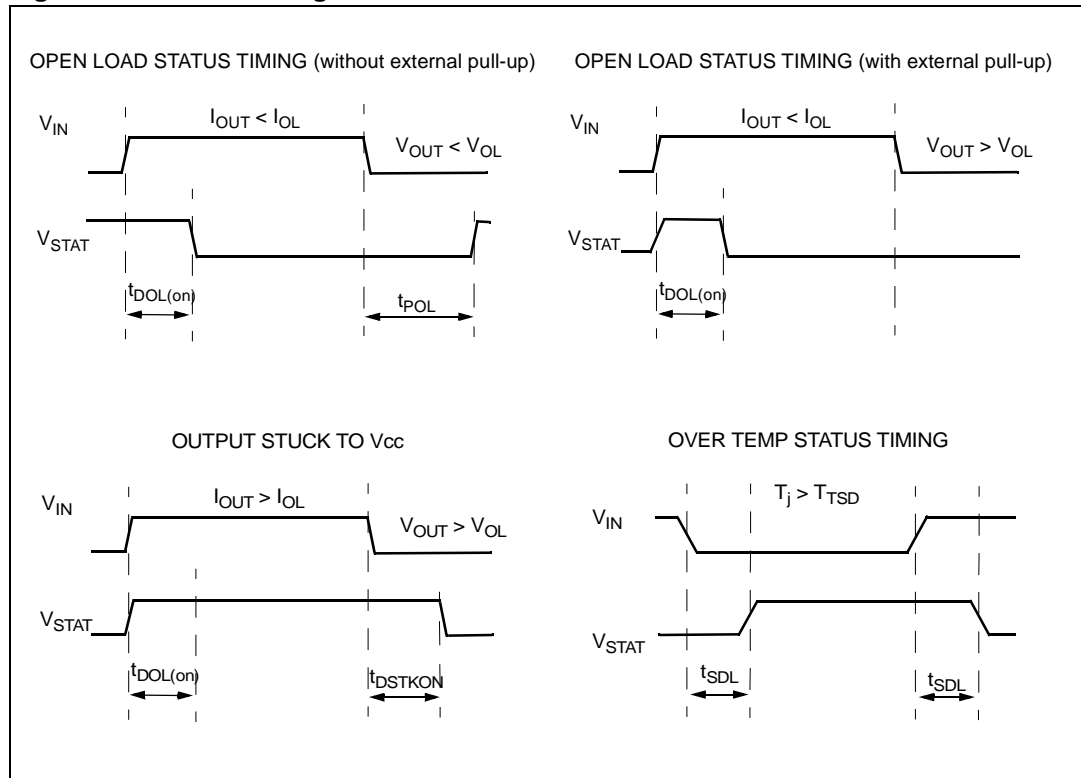

Figure 5. Output voltage drop limitation

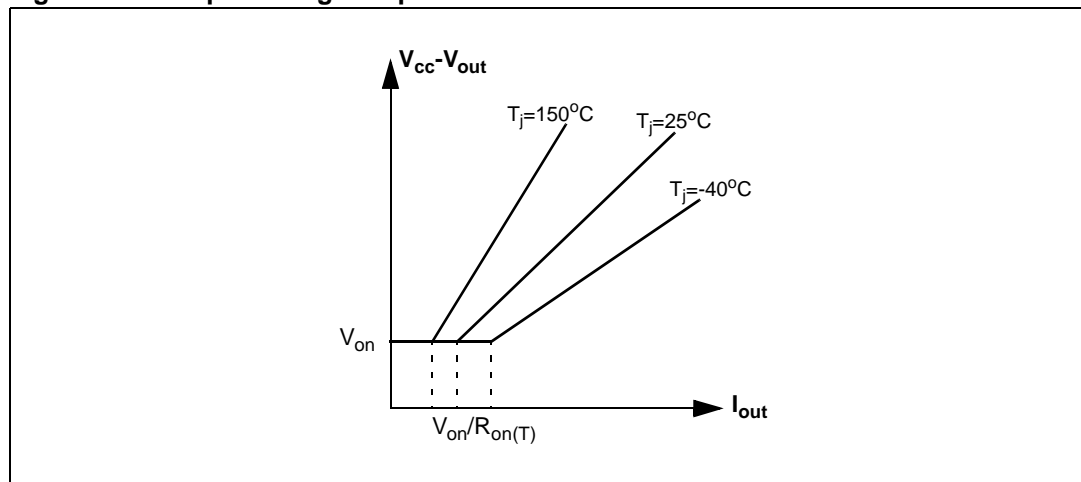

Table 12. Truth table

Conditions	Input	Output	Status ($V_{SD}=0V$) ⁽¹⁾
Normal operation	L	L	H
	H	H	H
Current limitation	L	L	H
	H	X	H

Table 12. Truth table (continued)

Conditions	Input	Output	Status ($V_{SD}=0V$) ⁽¹⁾
Over temperature	L	L	H
	H	L	L
Undervoltage	L	L	X
	H	L	X
Output voltage > V_{OL}	L	H	L ⁽²⁾
	H	H	H
Output current < I_{OL}	L	L	H ⁽³⁾
	H	H	L

1. If the V_{SD} is high, the STATUS pin is in a high impedance.
2. The STATUS pin is low with a delay equal to t_{DSTKON} after INPUT falling edge.
3. The STATUS pin becomes high with a delay equal to t_{POL} after INPUT falling edge.

Figure 6. Switching characteristics

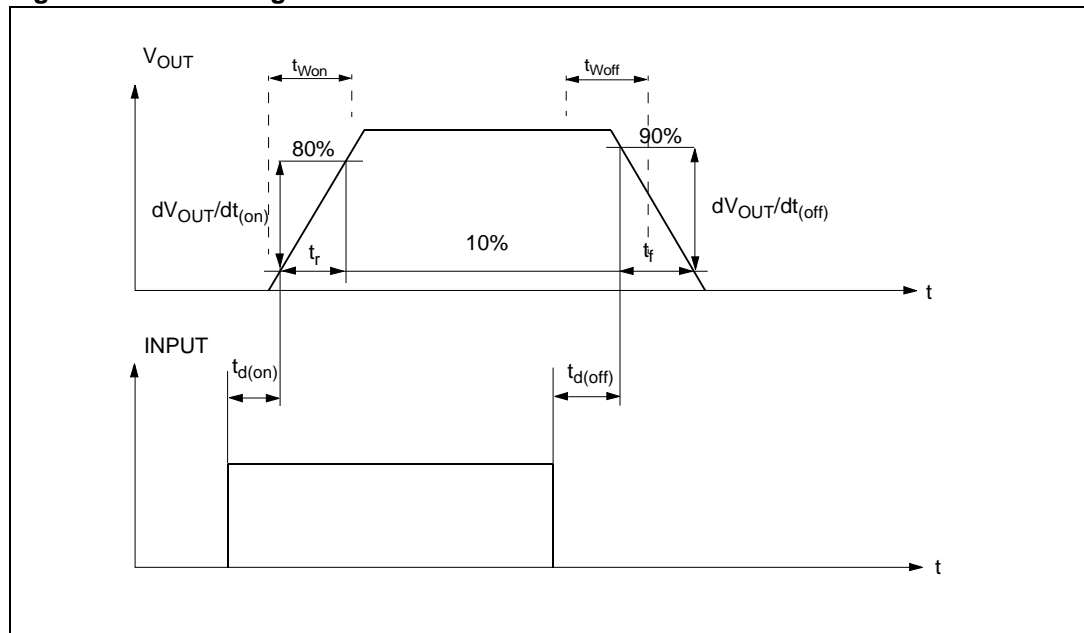

Table 13. Electrical transient requirements (part 1/3)

ISO 7637-2: 2004(E) test Pulse	Test levels ⁽¹⁾		Number of pulses or test times	Burst cycle/pulse repetition time		Delays and impedance
	III	IV				
1	-75 V	-100 V	5000 pulses	0.5 s	5 s	2 ms, 10 Ω
2a	+37 V	+50 V	5000 pulses	0.2 s	5 s	50 μs , 2 Ω
3a	-100 V	-150 V	1h	90 ms	100 ms	0.1 μs , 50 Ω
3b	+75 V	+100 V	1h	90 ms	100 ms	0.1 μs , 50 Ω

Table 13. Electrical transient requirements (part 1/3) (continued)

ISO 7637-2: 2004(E) test Pulse	Test levels ⁽¹⁾		Number of pulses or test times	Burst cycle/pulse repetition time	Delays and impedance
	III	IV			
4	-6 V	-7 V	1 pulse		100 ms, 0.01 Ω
5b ⁽²⁾	+65 V	+87 V	1 pulse		400 ms, 2 Ω

Table 14. Electrical transient requirements (part 2/3)

ISO 7637-2: 2004(E) test pulse	Test level results ⁽¹⁾	
	III	IV
1	C	C
2a	C	C
3a	C	C
3b	C	C
4	C	C
5b ⁽²⁾	C	C

1. The above test levels must be considered referred to Vcc = 13.5V except for pulse 5b
2. Valid in case of external load dump clamp: 40V maximum referred to ground.

Table 15. Electrical transient requirements (part 3/3)

Class	Contents
C	All functions of the device are performed as designed after exposure to disturbance.
E	One or more functions of the device are not performed as designed after exposure to disturbance and cannot be returned to proper operation without replacing the device.

2.4 Electrical characteristics curves

Figure 7. Off-state output current

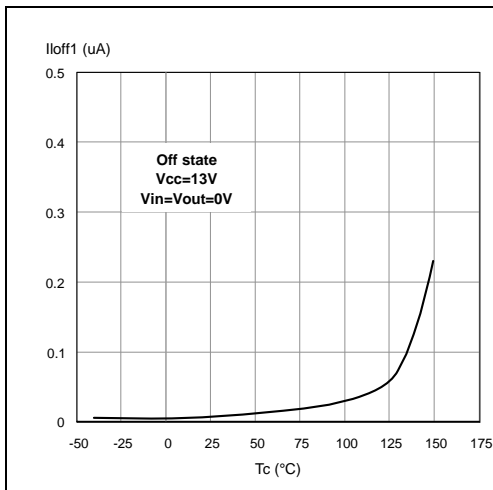

Figure 8. High level input current

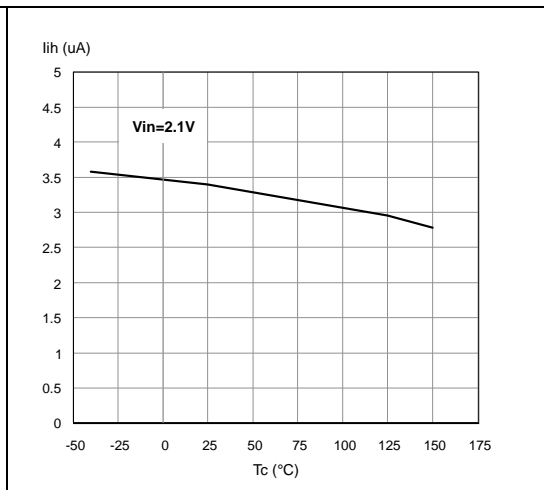

Figure 9. Input clamp voltage

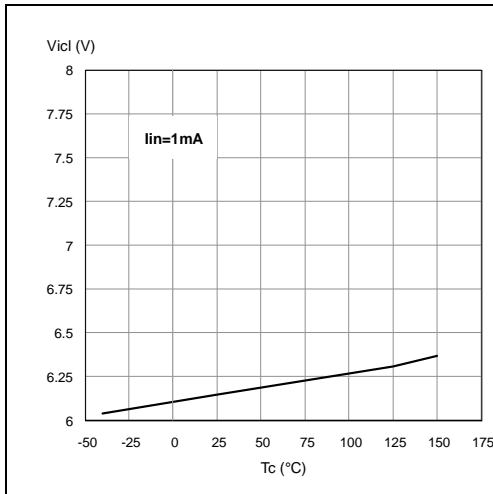

Figure 10. Input low level

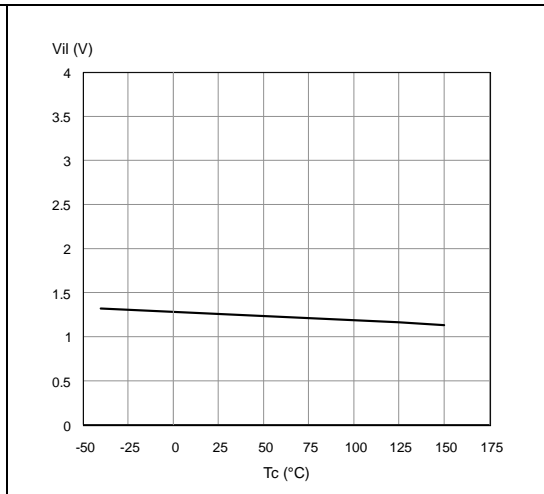

Figure 11. Input high level

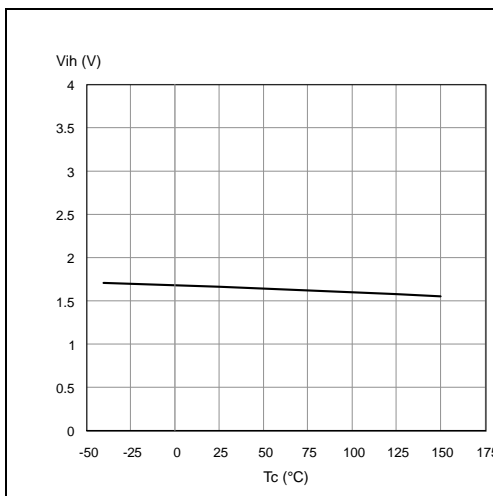

Figure 12. Input hysteresis voltage

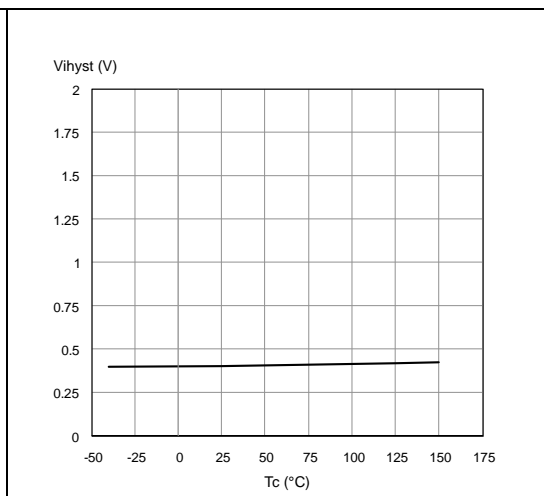

Figure 13. On-state resistance vs T_{case}

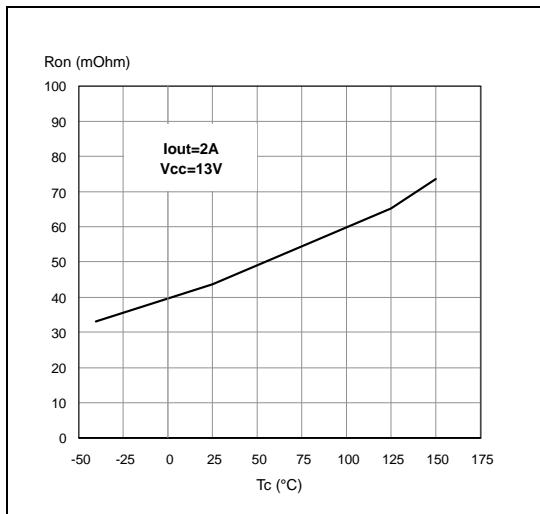

Figure 14. On-state resistance vs V_{CC}

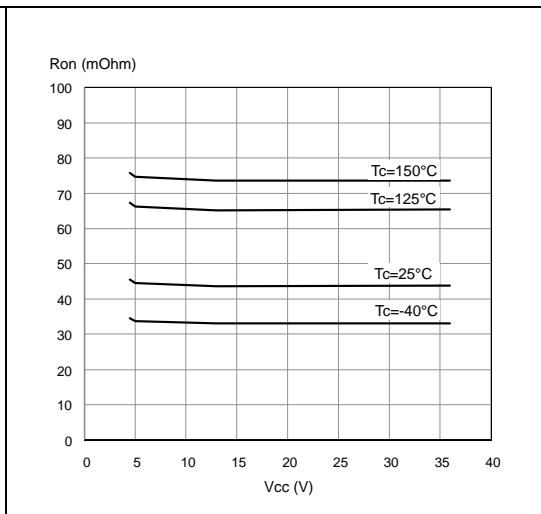

Figure 15. Undervoltage shutdown

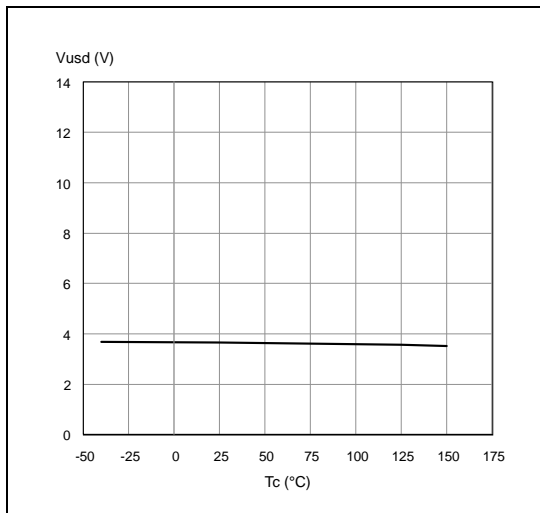

Figure 16. Turn-on voltage slope

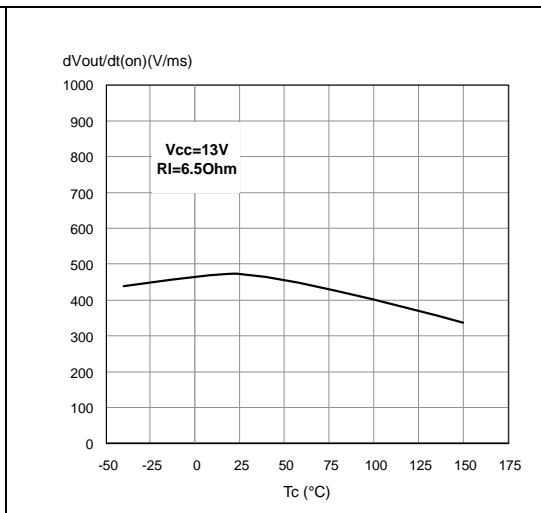

Figure 17. I_{LIMH} vs T_{case}

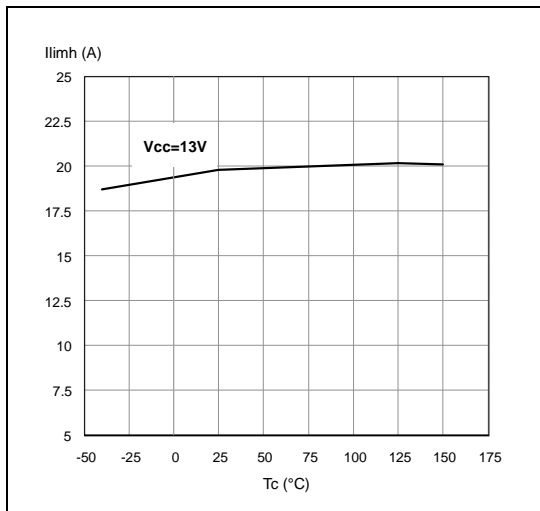

Figure 18. Turn-off voltage slope

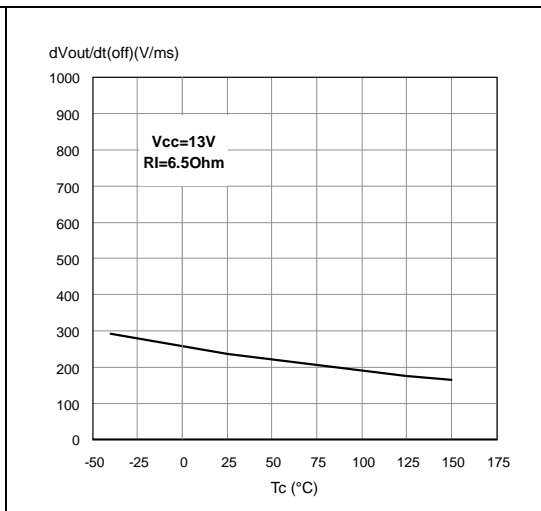

Figure 19. Status low output voltage

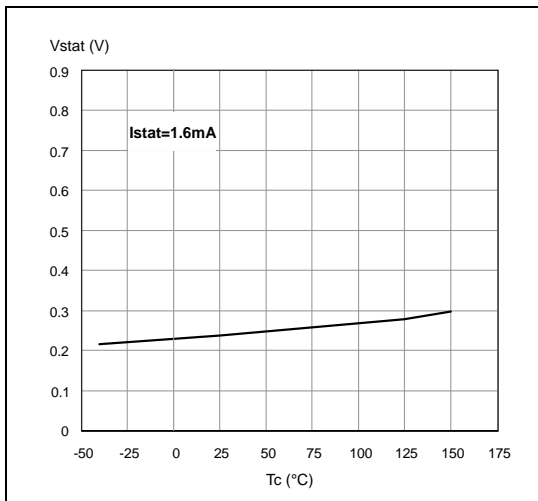

Figure 20. Status leakage current

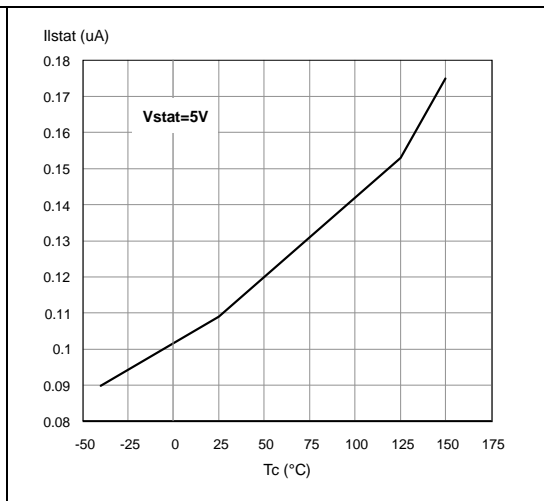

Figure 21. Status clamp voltage

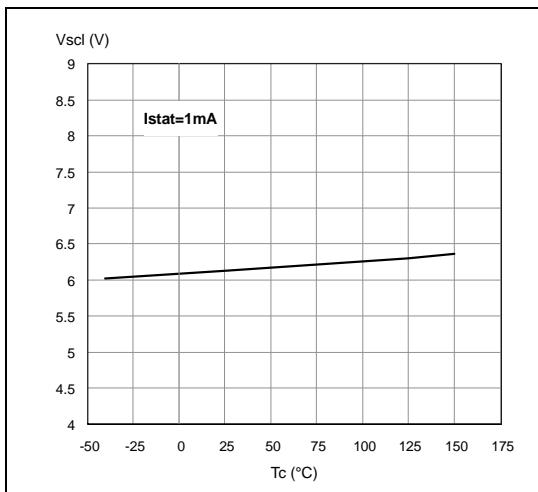

Figure 22. Open-load on-state detection threshold

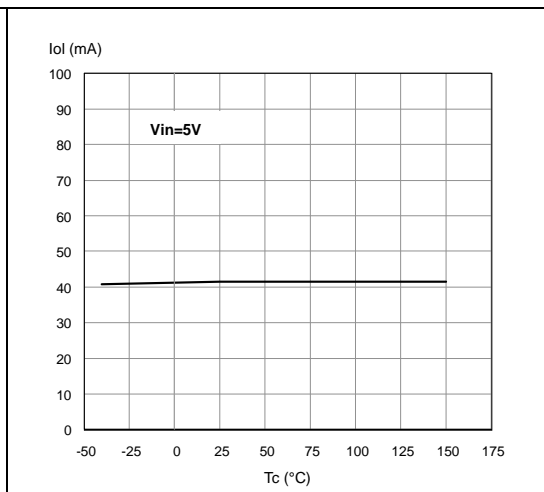

Figure 23. Open-load off-state voltage detection threshold

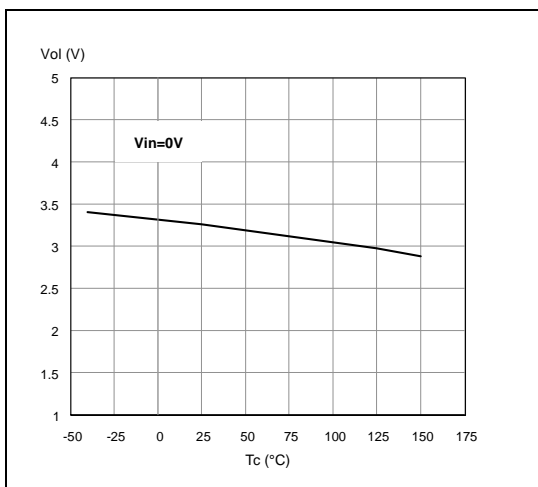

Figure 24. STAT_DIS clamp voltage

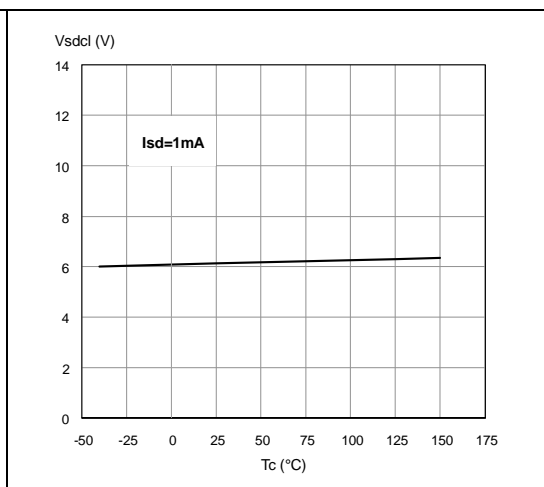
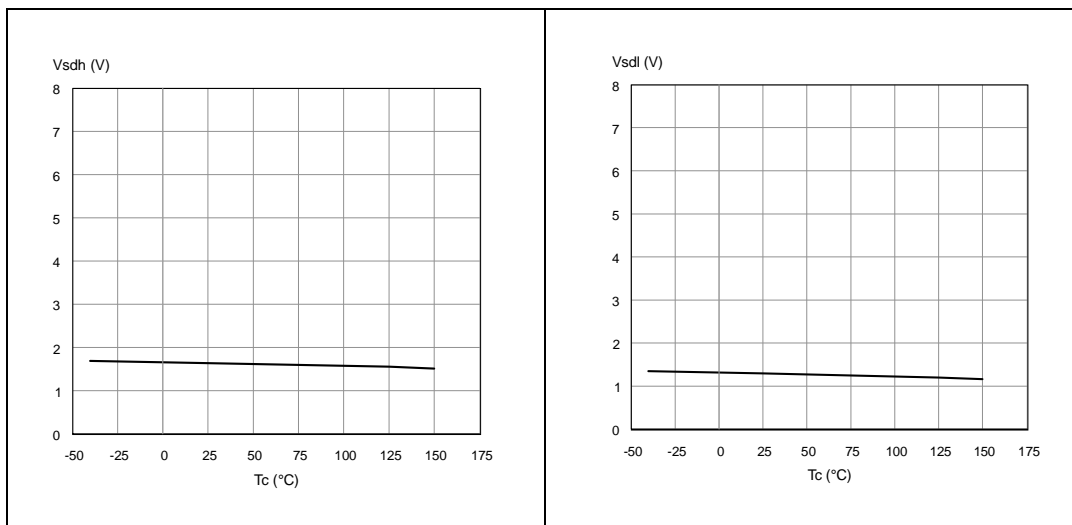
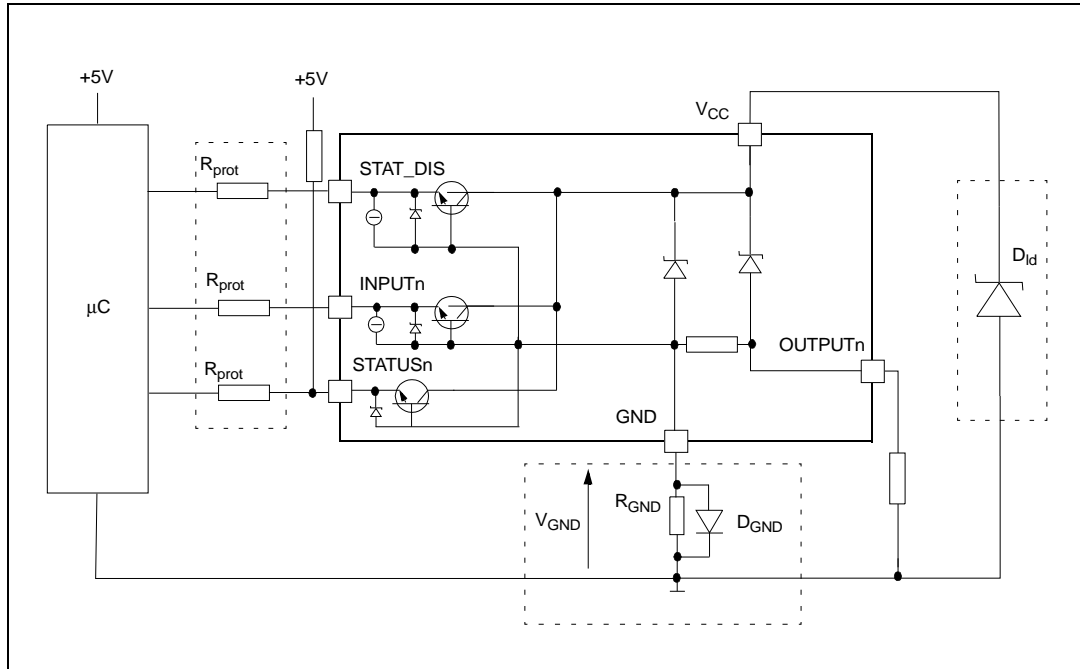

Figure 25. High level STAT_DIS voltage Figure 26. Low level STAT_DIS voltage



3 Application information

Figure 27. Application schematic



Note: Channels 2, 3 and 4 have the same internal circuit as channel 1.

3.1 GND protection network against reverse battery

3.1.1 Solution 1: resistor in the ground line (R_{GND} only)

This can be used with any type of load.

The following is an indication on how to dimension the R_{GND} resistor.

1. $R_{GND} \leq 600\text{mV} / (I_{S(on)max})$.
2. $R_{GND} \geq (-V_{CC}) / (-I_{GND})$

where $-I_{GND}$ is the DC reverse ground pin current and can be found in the absolute maximum rating section of the device datasheet.

Power Dissipation in R_{GND} (when $V_{CC} < 0$: during reverse battery situations) is:

$$P_D = (-V_{CC})^2 / R_{GND}$$

This resistor can be shared amongst several different HSDs. Please note that the value of this resistor should be calculated with formula (1) where $I_{S(on)max}$ becomes the sum of the maximum on-state currents of the different devices.

Please note that if the microprocessor ground is not shared by the device ground then the R_{GND} will produce a shift ($I_{S(on)max} * R_{GND}$) in the input thresholds and the status output values. This shift will vary depending on how many devices are ON in the case of several high side drivers sharing the same R_{GND} .

If the calculated power dissipation leads to a large resistor or several devices have to share the same resistor then ST suggests to utilize Solution 2 (see below).

3.1.2 Solution 2: a diode (D_{GND}) in the ground line

A resistor ($R_{GND}=1k\Omega$) should be inserted in parallel to D_{GND} if the device drives an inductive load.

This small signal diode can be safely shared amongst several different HSDs. Also in this case, the presence of the ground network will produce a shift ($\approx 600mV$) in the input threshold and in the status output values if the microprocessor ground is not common to the device ground. This shift will not vary if more than one HSD shares the same diode/resistor network.

3.2 Load dump protection

D_{ld} is necessary (Voltage Transient Suppressor) if the load dump peak voltage exceeds the V_{CC} max DC rating. The same applies if the device is subject to transients on the V_{CC} line that are greater than the ones shown in the ISO T/R 7637/1 table.

3.3 Microprocessor I/Os protection

If a ground protection network is used and negative transients are present on the V_{CC} line, the control pins will be pulled negative. ST suggests to insert a resistor (R_{prot}) in line to prevent the μC I/Os pins to latch-up.

The value of these resistors is a compromise between the leakage current of μC and the current required by the HSD I/Os (Input levels compatibility) with the latch-up limit of μC I/Os.

$$-V_{CCpeak}/I_{latchup} \leq R_{prot} \leq (V_{OH\mu C} - V_{IH} - V_{GND}) / I_{IHmax}$$

Calculation example:

For $V_{CCpeak} = -100V$ and $I_{latchup} \geq 20mA$; $V_{OH\mu C} \geq 4.5V$

$$5k\Omega \leq R_{prot} \leq 65k\Omega.$$

Recommended value: $R_{prot} = 10k\Omega$.

3.4 Open-load detection in off-state

Off-state open-load detection requires an external pull-up resistor (R_{PU}) connected between OUTPUT pin and a positive supply voltage (V_{PU}) like the +5V line used to supply the microprocessor.

The external resistor has to be selected according to the following requirements:

- no false open-load indication when load is connected: in this case we have to avoid V_{OUT} to be higher than V_{OLmin} ; this results in the following condition $V_{OUT} = (V_{PU} / (R_L + R_{PU})) R_L < V_{OLmin}$.
- no misdetection when load is disconnected: in this case the V_{OUT} has to be higher than V_{OLmax} ; this results in the following condition $R_{PU} < (V_{PU} - V_{OLmax}) / I_{L(off2)}$.

Because $I_{s(OFF)}$ may significantly increase if V_{out} is pulled high (up to several mA), the pull-up resistor R_{PU} should be connected to a supply that is switched OFF when the module is in standby.

The values of V_{OLmin} , V_{OLmax} and $I_{L(off2)}$ are available in the Electrical Characteristics section.

Figure 28. Open-load detection in off-state

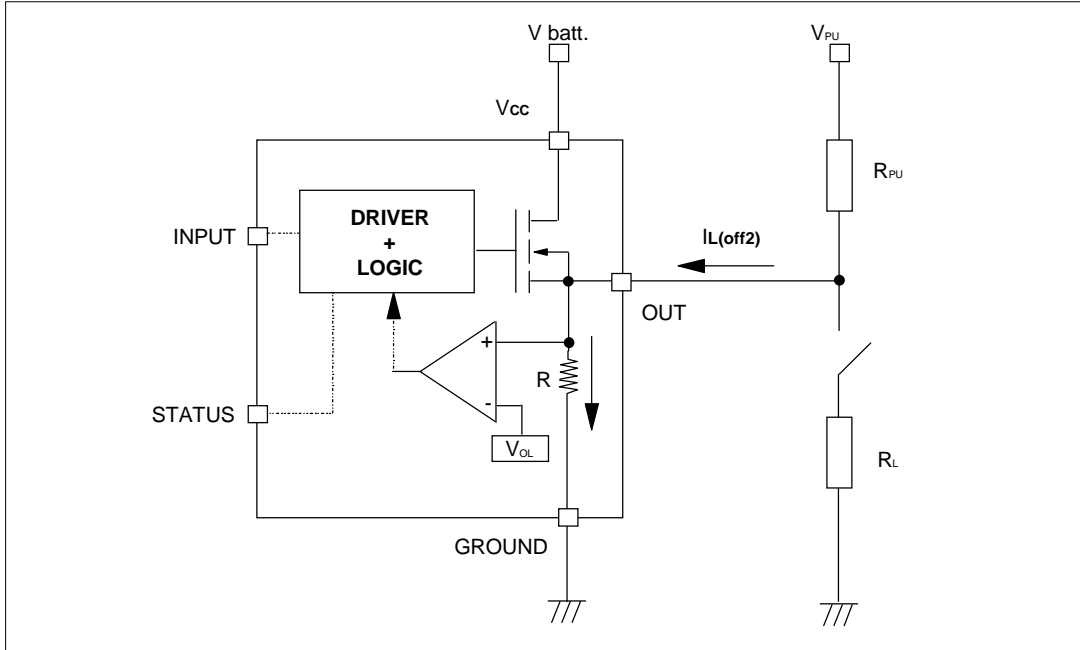
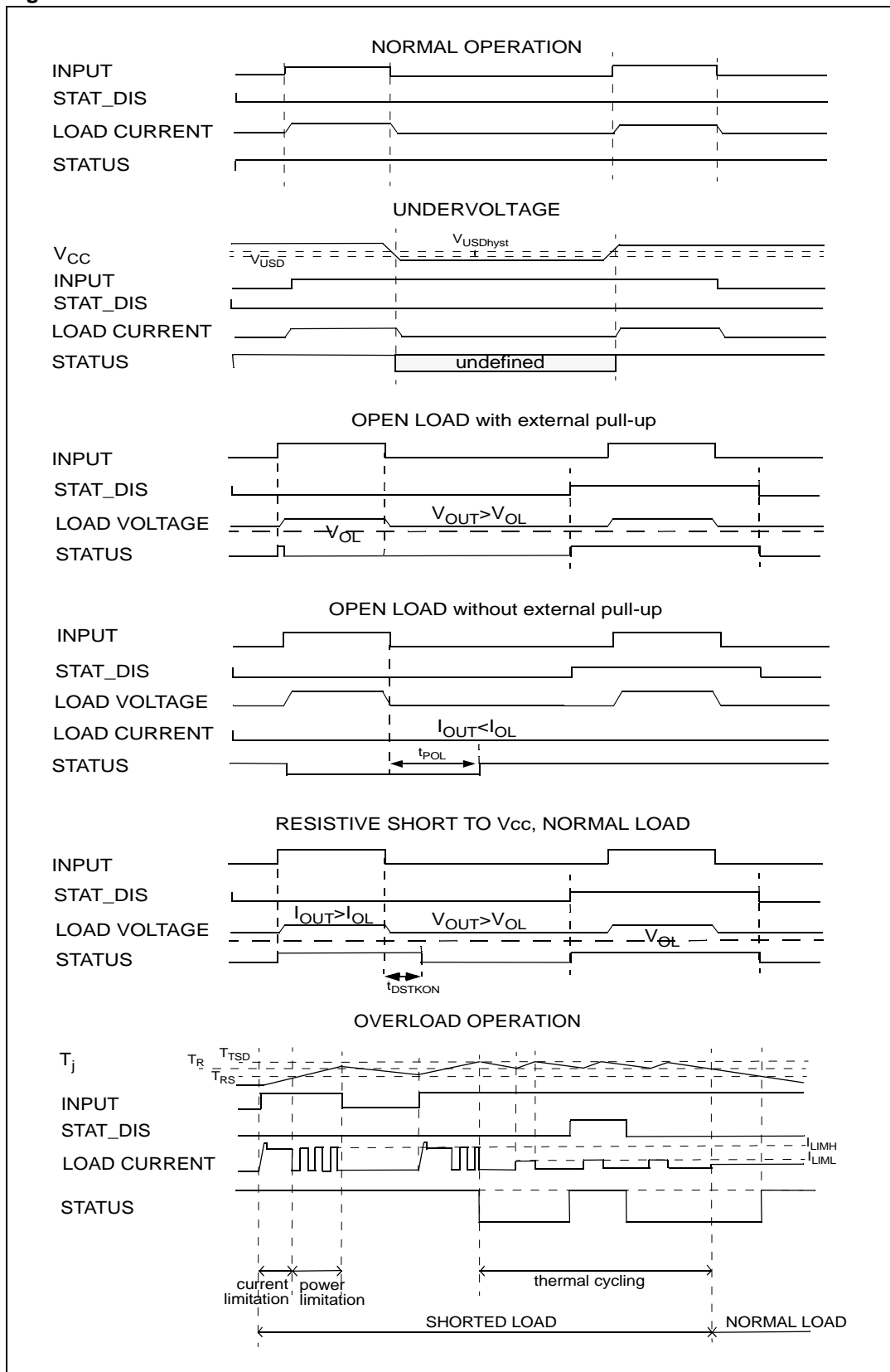
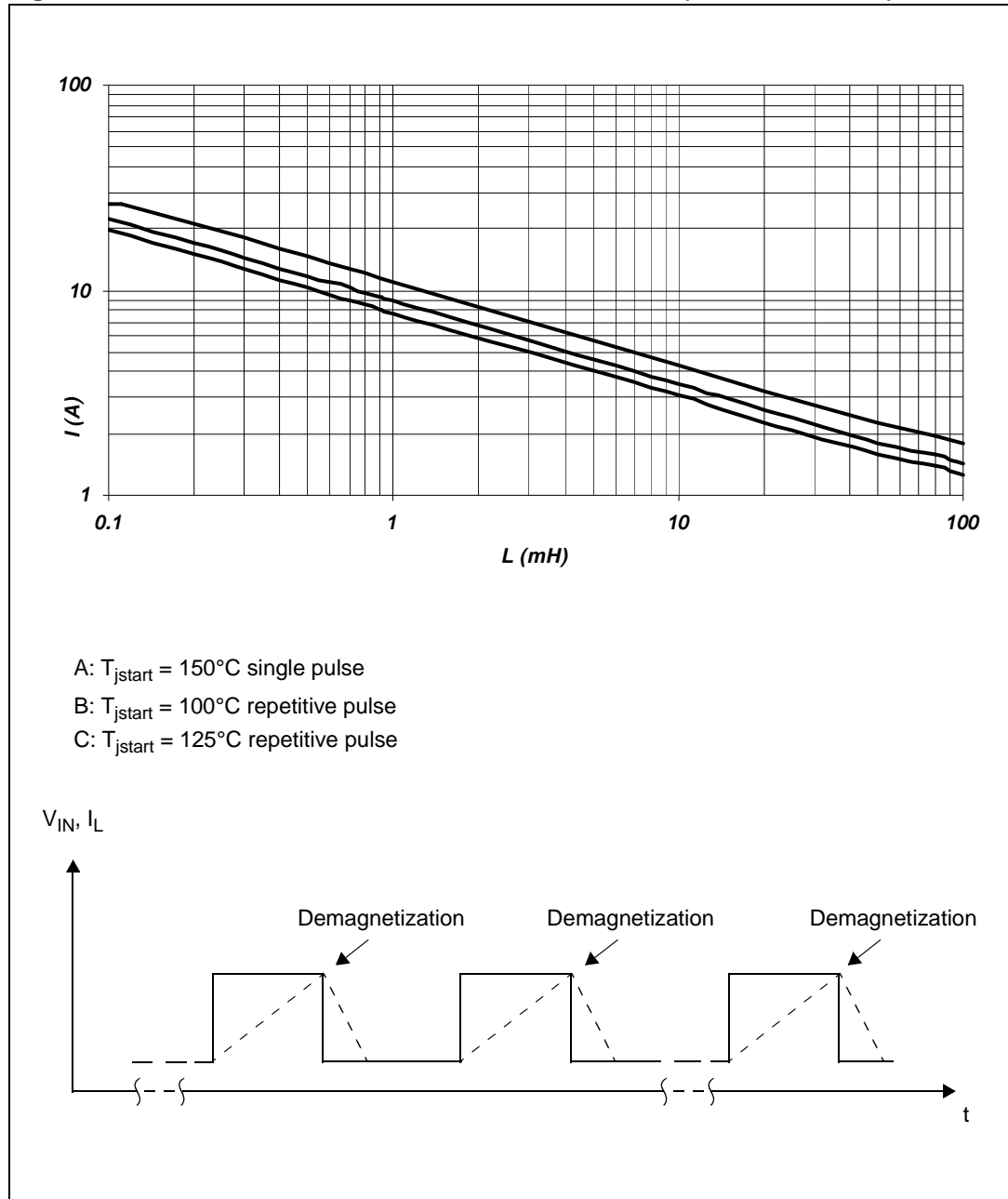

Figure 29. Waveforms



3.5 Maximum demagnetization energy ($V_{CC} = 13.5V$)

Figure 30. Maximum turn-off current versus inductance (for each channel)



Note: Values are generated with $R_L = 0 \Omega$
 In case of repetitive pulses, T_{jstart} (at beginning of each demagnetization) of every pulse must not exceed the temperature specified above for curves A and B.

4 Package and PC board thermal data

4.1 PowerSSO-24 thermal data

Figure 31. PowerSSO-24 PC board

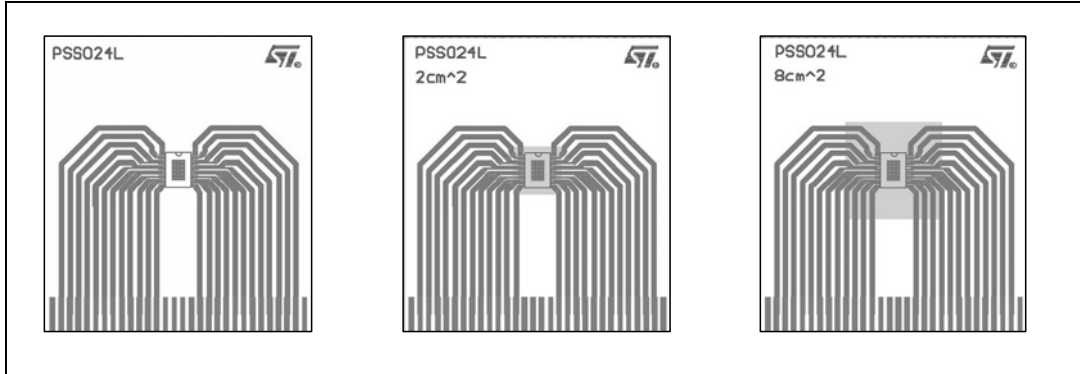

Note: Layout condition of R_{th} and Z_{th} measurements (PCB: Double layer, Thermal Vias, FR4 area= 77 mm x 86 mm, PCB thickness=1.6mm, Cu thickness=70 μ m (front and back side), Copper areas: from minimum pad lay-out to 8 cm²).

Figure 32. $R_{thj-amb}$ vs PCB copper area in open box free air condition (one channel on)

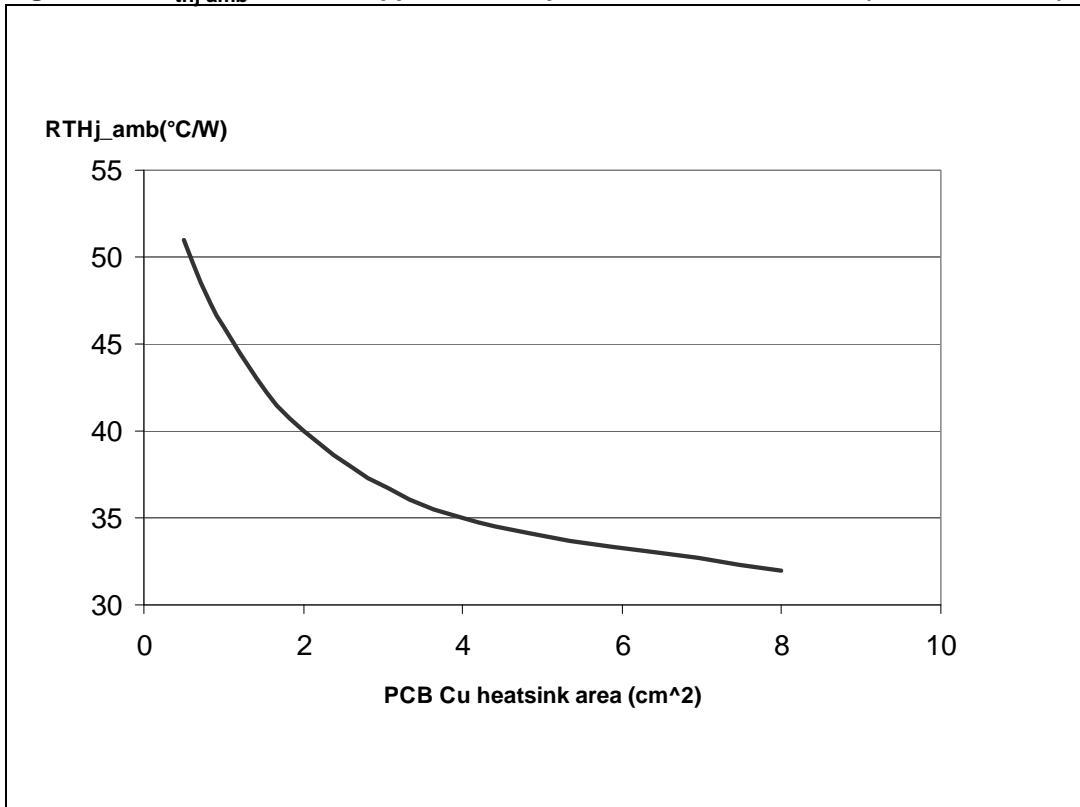

Figure 33. PowerSSO-24 thermal impedance junction ambient single pulse (one channel on)

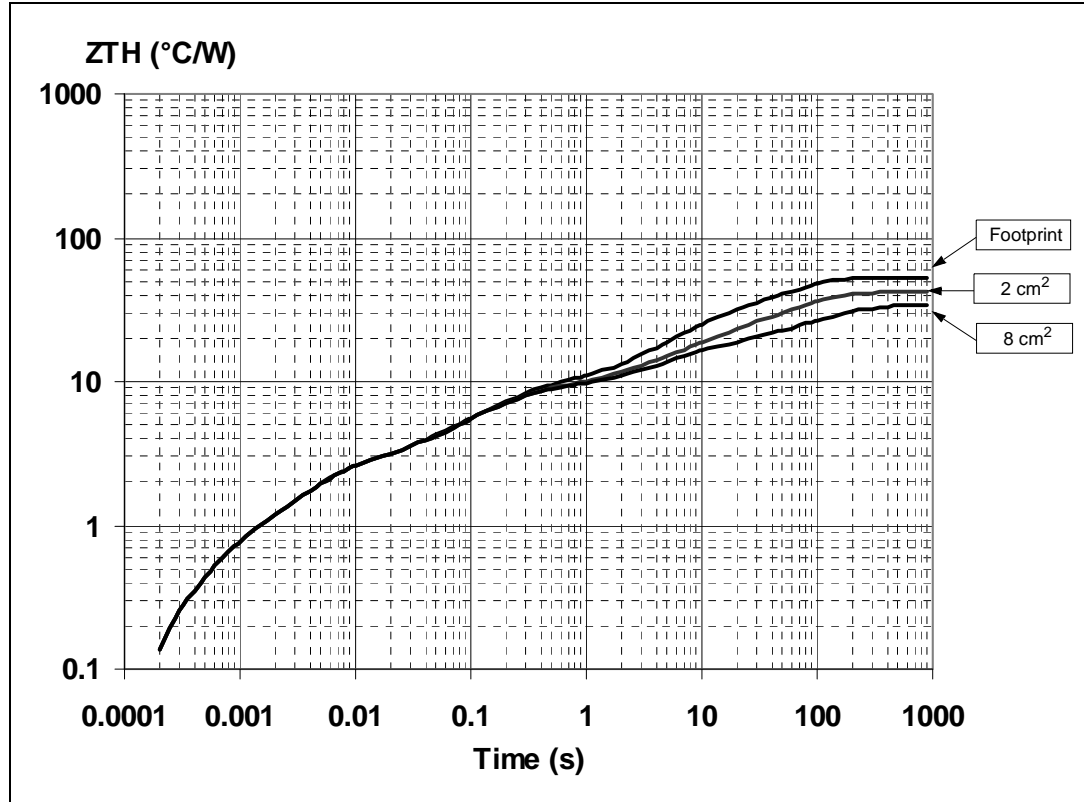

Figure 34. Thermal fitting model of a double channel HSD in PowerSSO-24^(a)



a. The fitting model is a simplified thermal tool and is valid for transient evolutions where the embedded protections (power limitation or thermal cycling during thermal shutdown) are not triggered

Equation 1: pulse calculation formula

$$Z_{TH\delta} = R_{TH} \cdot \delta + Z_{THtp}(1 - \delta)$$

$$\text{where } \delta = t_p/T$$

Table 16. Thermal parameters

Area/island (cm ²)	Footprint	2	8
R1=R7=R9=R11 (°C/W)	0.4		
R2=R8=R10=R12 (°C/W)	2		
R3 (°C/W)	6		
R4 (°C/W)	7.7		
R5 (°C/W)	9	9	8
R6 (°C/W)	28	17	10
C1=C7=C9=C11 (W.s/°C)	0.001		
C2=C8=C10=C12 (W.s/°C)	0.0022		
C3 (W.s/°C)	0.025		
C4 (W.s/°C)	0.75		
C5 (W.s/°C)	1	4	9
C6 (W.s/°C)	2.2	5	17

5 Package and packing information

5.1 ECOPACK[®] packages

In order to meet environmental requirements, ST offers these devices in different grades of ECOPACK[®] packages, depending on their level of environmental compliance. ECOPACK[®] specifications, grade definitions and product status are available at: www.st.com.

ECOPACK[®] is an ST trademark.

5.2 PowerSSO-24[™] mechanical data

Figure 35. PowerSSO-24[™] package dimensions

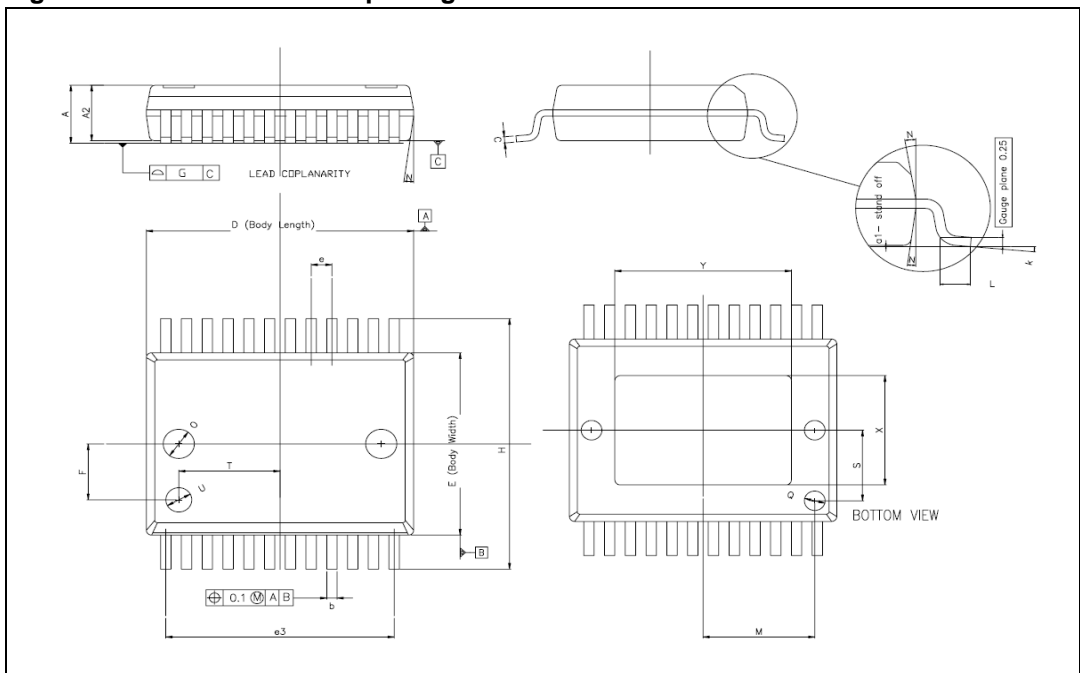

Table 17. PowerSSO-24™ mechanical data

Symbol	Millimeters		
	Min	Typ	Max
A			2.45
A2	2.15		2.35
a1	0		0.1
b	0.33		0.51
c	0.23		0.32
D	10.10		10.50
E	7.4		7.6
e		0.8	
e3		8.8	
F		2.3	
G			0.1
H	10.1		10.5
h			0.4
k	0 deg		8 deg
L	0.55		0.85
O		1.2	
Q		0.8	
S		2.9	
T		3.65	
U		1.0	
N			10 deg
X	4.1		4.7
Y	6.5		7.1

5.3 Packing information

Figure 36. PowerSSO-24 tube shipment (no suffix)

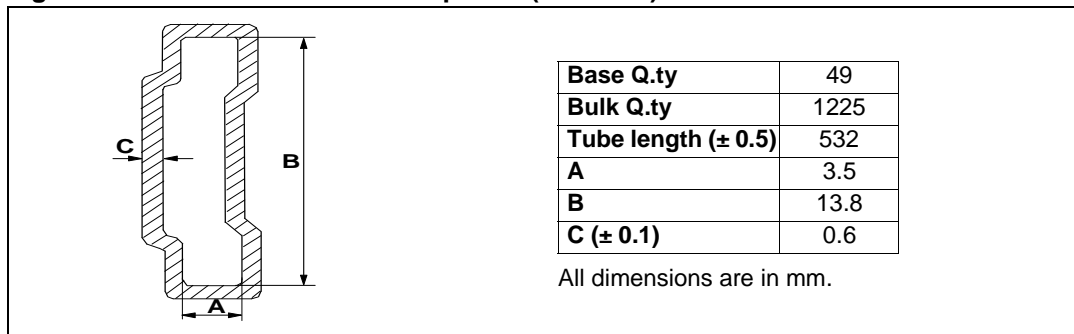
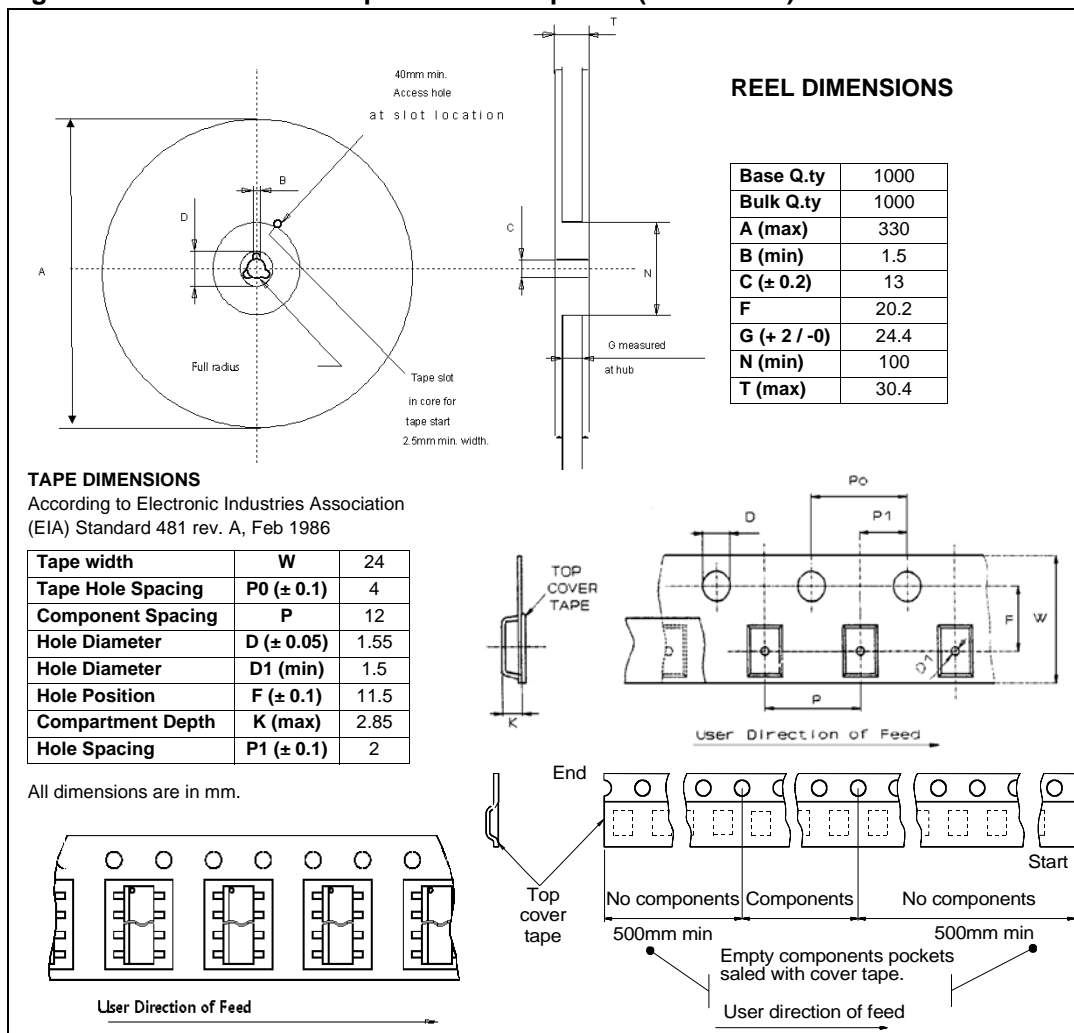

Figure 37. PowerSSO-24 tape and reel shipment (suffix "TR")



6 Revision history

Table 18. Document revision history

Date	Revision	Changes
01-Oct-2004	1	Initial release.
01-Mar-2005	2	Minor changes.
04-Jun-2007	3	Reformatted and restructured. Contents and lists of tables and figures added. <i>Section 3.5: Maximum demagnetization energy (VCC = 13.5V)</i> added. <i>ECOPACK® packages</i> information added. New disclaimer added. <i>Table 4: Absolute maximum ratings:</i> EMAX entries updated. <i>Table 13: Electrical transient requirements (part 1/3):</i> Test level values III and IV for test pulse 5b and notes updated <i>Figure 34: Thermal fitting model of a double channel HSD in PowerSSO-24</i> note added
24-Jul-2007	4	<i>Table 17: PowerSSO-24™ mechanical data</i> updated
17-Jun-2009	5	<i>Table 17: PowerSSO-24™ mechanical data:</i> – Deleted A (min) value – Changed A (max) value from 2.47 to 2.45 – Changed A2 (max) value from 2.40 to 2.35 – Changed a1 (max) value from 0.075 to 0.1 – Added F row – Updated k row
22-Jun-2009	6	Updated <i>Figure 35: PowerSSO-24™ package dimensions</i> Updated <i>Table 17: PowerSSO-24™ mechanical data:</i> – Deleted G1 row – Added O, Q, S, T, and U rows
25-Sep-2013	7	Updated disclaimer.

Please Read Carefully:

Information in this document is provided solely in connection with ST products. STMicroelectronics NV and its subsidiaries ("ST") reserve the right to make changes, corrections, modifications or improvements, to this document, and the products and services described herein at any time, without notice.

All ST products are sold pursuant to ST's terms and conditions of sale.

Purchasers are solely responsible for the choice, selection and use of the ST products and services described herein, and ST assumes no liability whatsoever relating to the choice, selection or use of the ST products and services described herein.

No license, express or implied, by estoppel or otherwise, to any intellectual property rights is granted under this document. If any part of this document refers to any third party products or services it shall not be deemed a license grant by ST for the use of such third party products or services, or any intellectual property contained therein or considered as a warranty covering the use in any manner whatsoever of such third party products or services or any intellectual property contained therein.

UNLESS OTHERWISE SET FORTH IN ST'S TERMS AND CONDITIONS OF SALE ST DISCLAIMS ANY EXPRESS OR IMPLIED WARRANTY WITH RESPECT TO THE USE AND/OR SALE OF ST PRODUCTS INCLUDING WITHOUT LIMITATION IMPLIED WARRANTIES OF MERCHANTABILITY, FITNESS FOR A PARTICULAR PURPOSE (AND THEIR EQUIVALENTS UNDER THE LAWS OF ANY JURISDICTION), OR INFRINGEMENT OF ANY PATENT, COPYRIGHT OR OTHER INTELLECTUAL PROPERTY RIGHT.

ST PRODUCTS ARE NOT DESIGNED OR AUTHORIZED FOR USE IN: (A) SAFETY CRITICAL APPLICATIONS SUCH AS LIFE SUPPORTING, ACTIVE IMPLANTED DEVICES OR SYSTEMS WITH PRODUCT FUNCTIONAL SAFETY REQUIREMENTS; (B) AERONAUTIC APPLICATIONS; (C) AUTOMOTIVE APPLICATIONS OR ENVIRONMENTS, AND/OR (D) AEROSPACE APPLICATIONS OR ENVIRONMENTS. WHERE ST PRODUCTS ARE NOT DESIGNED FOR SUCH USE, THE PURCHASER SHALL USE PRODUCTS AT PURCHASER'S SOLE RISK, EVEN IF ST HAS BEEN INFORMED IN WRITING OF SUCH USAGE, UNLESS A PRODUCT IS EXPRESSLY DESIGNATED BY ST AS BEING INTENDED FOR "AUTOMOTIVE, AUTOMOTIVE SAFETY OR MEDICAL" INDUSTRY DOMAINS ACCORDING TO ST PRODUCT DESIGN SPECIFICATIONS. PRODUCTS FORMALLY ESCC, QML OR JAN QUALIFIED ARE DEEMED SUITABLE FOR USE IN AEROSPACE BY THE CORRESPONDING GOVERNMENTAL AGENCY.

Resale of ST products with provisions different from the statements and/or technical features set forth in this document shall immediately void any warranty granted by ST for the ST product or service described herein and shall not create or extend in any manner whatsoever, any liability of ST.

ST and the ST logo are trademarks or registered trademarks of ST in various countries.

Information in this document supersedes and replaces all information previously supplied.

The ST logo is a registered trademark of STMicroelectronics. All other names are the property of their respective owners.

© 2013 STMicroelectronics - All rights reserved

STMicroelectronics group of companies

Australia - Belgium - Brazil - Canada - China - Czech Republic - Finland - France - Germany - Hong Kong - India - Israel - Italy - Japan - Malaysia - Malta - Morocco - Philippines - Singapore - Spain - Sweden - Switzerland - United Kingdom - United States of America

www.st.com

Компания «Океан Электроники» предлагает заключение долгосрочных отношений при поставках импортных электронных компонентов на взаимовыгодных условиях!

Наши преимущества:

- Поставка оригинальных импортных электронных компонентов напрямую с производств Америки, Европы и Азии, а так же с крупнейших складов мира;
- Широкая линейка поставок активных и пассивных импортных электронных компонентов (более 30 млн. наименований);
- Поставка сложных, дефицитных, либо снятых с производства позиций;
- Оперативные сроки поставки под заказ (от 5 рабочих дней);
- Экспресс доставка в любую точку России;
- Помощь Конструкторского Отдела и консультации квалифицированных инженеров;
- Техническая поддержка проекта, помощь в подборе аналогов, поставка прототипов;
- Поставка электронных компонентов под контролем ВП;
- Система менеджмента качества сертифицирована по Международному стандарту ISO 9001;
- При необходимости вся продукция военного и аэрокосмического назначения проходит испытания и сертификацию в лаборатории (по согласованию с заказчиком);
- Поставка специализированных компонентов военного и аэрокосмического уровня качества (Xilinx, Altera, Analog Devices, Intersil, Interpoint, Microsemi, Actel, Aeroflex, Peregrine, VPT, Syfer, Eurofarad, Texas Instruments, MS Kennedy, Miteq, Cobham, E2V, MA-COM, Hittite, Mini-Circuits, General Dynamics и др.);

Компания «Океан Электроники» является официальным дистрибьютором и эксклюзивным представителем в России одного из крупнейших производителей разъемов военного и аэрокосмического назначения «JONHON», а так же официальным дистрибьютором и эксклюзивным представителем в России производителя высокотехнологичных и надежных решений для передачи СВЧ сигналов «FORSTAR».



JONHON

«JONHON» (основан в 1970 г.)

Разъемы специального, военного и аэрокосмического назначения:

(Применяются в военной, авиационной, аэрокосмической, морской, железнодорожной, горно- и нефтедобывающей отраслях промышленности)

«FORSTAR» (основан в 1998 г.)

ВЧ соединители, коаксиальные кабели, кабельные сборки и микроволновые компоненты:

(Применяются в телекоммуникациях гражданского и специального назначения, в средствах связи, РЛС, а так же военной, авиационной и аэрокосмической отраслях промышленности).



Телефон: 8 (812) 309-75-97 (многоканальный)

Факс: 8 (812) 320-03-32

Электронная почта: ocean@oceanchips.ru

Web: <http://oceanchips.ru/>

Адрес: 198099, г. Санкт-Петербург, ул. Калинина, д. 2, корп. 4, лит. А