

Switching Regulator Series

Step-Down DC/DC Converter BD9C601EFJ Evaluation Board

BD9C601EFJ-EVK-001

Description

This evaluation board has been developed for ROHM's synchronous buck DC/DC converter customers evaluating BD9C601EFJ. While accepting a power supply of 7.2-18V, an output of 5.0V can be produced. The IC has internal 50mΩ high-side P-channel MOSFET and 35mΩ low-side N-channel MOSFET and a synchronization frequency is of 500kHz. A Soft Start circuit prevents in-rush current during startup. An EN pin allows for simple ON/OFF control of the IC to reduce standby current consumption. Include OCP (Over Current Protection) and SCP (Short Circuit Protection).

Evaluation Board Operating Limits and Absolute Maximum Ratings (Ta=25°C)

Parameter	Symbol	Limit			Unit	Conditions
		MIN	TYP	MAX		
Supply Voltage	V _{CC}	(NOTE1) 4.5	-	18	V	
Output Voltage / Current	V _{OUT}	-	5.0	-	V	
	I _{OUT}	-	-	6	A	

(NOTE1) When the output voltage is 5.0V, it is 7.2V by limiting ratio of the maximum duty.

Evaluation Board

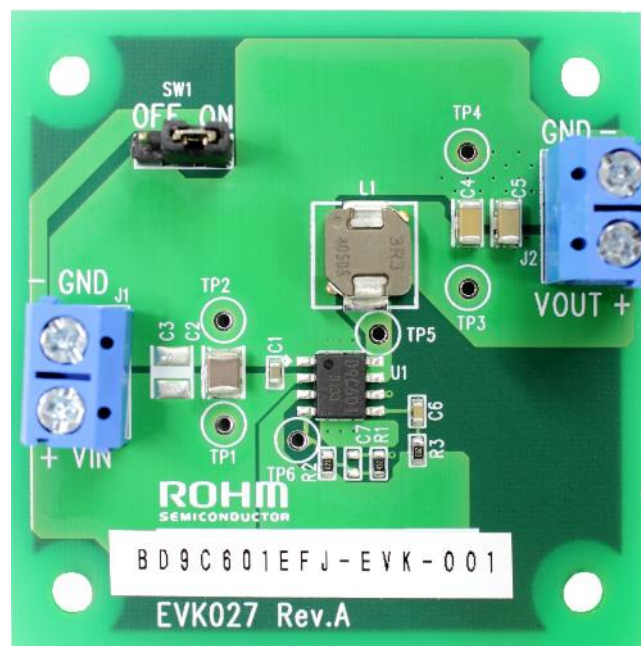

Figure 1. BD9C601EFJ-EVK-001 Evaluation Board

Operation Procedures

1. Necessary equipments

- (1) DC power-supply of 7.2V to 18V/6A
- (2) Maximum 6A load
- (3) DC voltmeter

2. Connecting the equipments

- (1) DC power-supply presets to 12V and then the power output turns off.
- (2) The max. load should be set at 6A and over it will be disabled.
- (3) Check Jumper pin of SW1 is short, between intermediate-terminal and OFF-side terminal.
- (4) Connect positive-terminal of power-supply to VIN+terminal and negative-terminal to GND-terminal with a pair of wires.
- (5) Connect load's positive-terminal to VOUT+terminal and negative-terminal to GND-terminal with a pair of wires.
- (6) Connect positive-terminal of DC voltmeter 1 to TP1 and negative-terminal to TP2 for input-voltage measurement.
- (7) Connect positive-terminal of DC voltmeter 2 to TP3 and negative-terminal to TP4 for output-voltage measurement.
- (8) DC power-supply output is turned ON.
- (9) IC is enable (EN) by shorting Jumper-pin of SW1 between intermediate-terminal and ON-side terminal.
- (10) Check DC voltmeter 2 displays 5.0V.
- (11) The load is enabled.
- (12) Check at DC voltmeter 1 whether the voltage-drop (loss) is not caused by the wire's resistance.

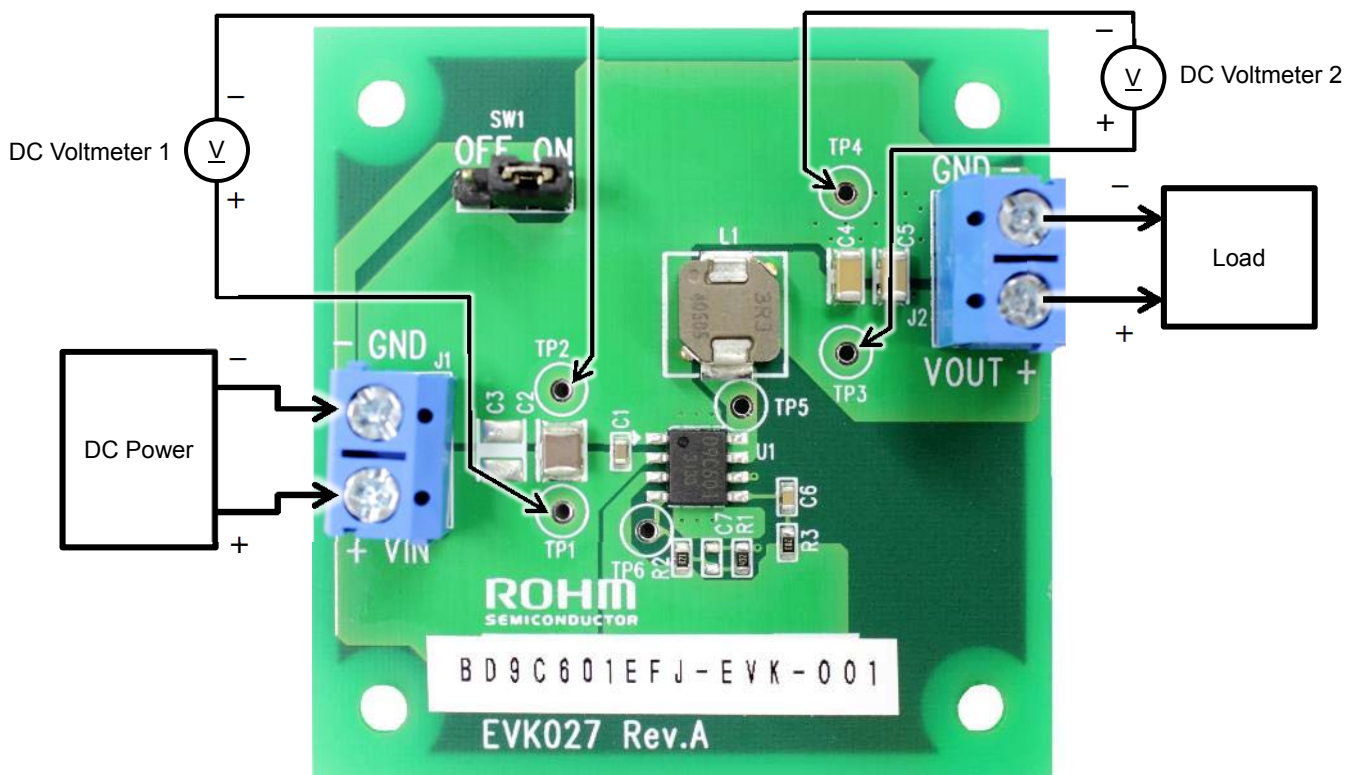

Figure 2. Connection Diagram

Enable-Pin

To minimize current consumption during standby-mode and normal operation, Enable-mode can be switched by controlling EN pin (6pin) of the IC. Standby-mode is enabled by shorting Jumper-pin of SW1 between intermediate-terminal and OFF-side terminal and normal-mode operation by shorting between intermediate-terminal and ON-side terminal. It also can be switched between standby-mode and normal-mode operation by removing Jumper-pin and controlling the voltage between EN and GND-terminal. Standby-mode is enabled when the voltage of EN is under 0.8V, and normal-mode operation when it is over 2.0V.

Circuit Diagram

$V_{IN} = 7.2V \sim 18V$, $V_{OUT} = 5.0V$

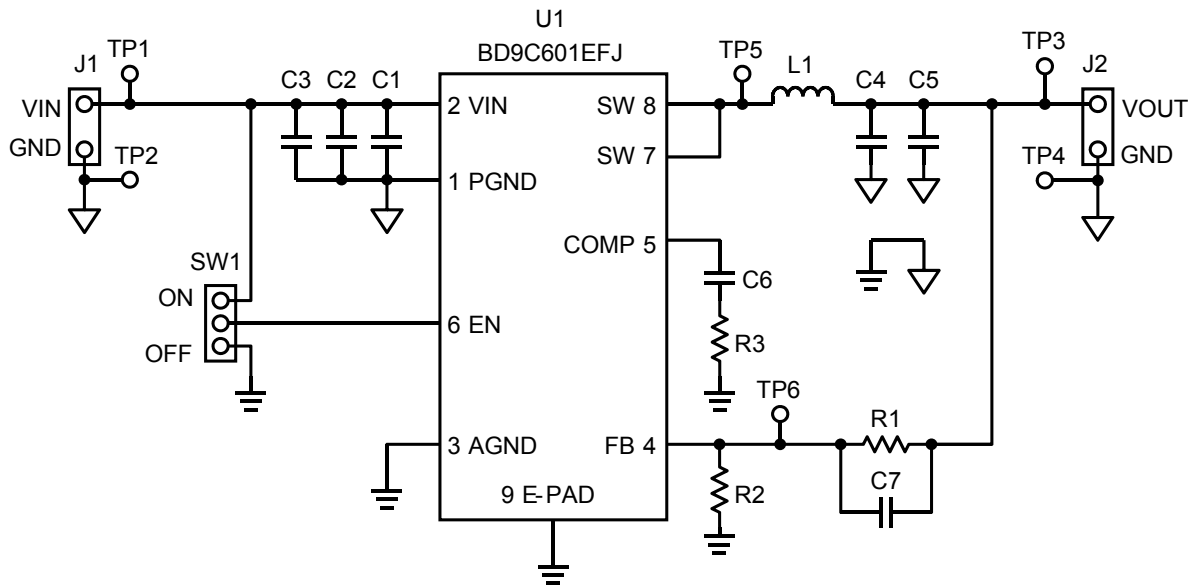

Figure 3. BD9C601EFJ-EVK-001 Circuit Diagram

Bill of Materials

Count	Reference Designator	Type	Value	Description	Manufacturer Part Number	Manufacturer	Configuration (mm)
1	C1	Ceramic Capacitor	0.1 μ F	50V, B, \pm 20%	GRM188B31H104MA92	MURATA	1608
1	C2	Ceramic Capacitor	10 μ F	35V, B, \pm 10%	GRM32EB3YA106KA12	MURATA	3225
0	C3	Ceramic Capacitor	-	Not installed	-	-	3225
2	C4, C5	Ceramic Capacitor	22 μ F	10V, B, \pm 10%	GRM31CB31A226KE19	MURATA	3216
1	C6	Ceramic Capacitor	1500pF	25V, B, \pm 10%	GRM188B11E152KA01	MURATA	1608
0	C7	Ceramic Capacitor	-	Not installed	-	-	3216
1	L1	Inductor	3.3 μ H	\pm 20%, DCR=29.7m Ω max, 7.3A	SPM6530T-3R3	TDK	7165
1	R1	Resistor	4.3k Ω	1/10W, 50V, 1%	MCR03ERPF4301	ROHM	1608
1	R2	Resistor	820 Ω	1/10W, 50V, 1%	MCR03ERPF8200	ROHM	1608
1	R3	Resistor	20k Ω	1/10W, 50V, 1%	MCR03ERPF2002	ROHM	1608
1	SW1	Pin header	-	2.54mm \times 3 contacts	PH-1x03SG	USECONN	-
1	U1	IC	-	Buck DC/DC Converter	BD9C601EFJ	ROHM	HTSOP-J8
2	J1, J2	Terminal Block	-	2 contacts, 15A, 14 to 22AWG	TB111-2-2-U-1-1	Alphaplus Connectors & Cables	-
1	-	Jumper	-	Jumper pin for SW1	MJ254-6BK	USECONN	-

Layout

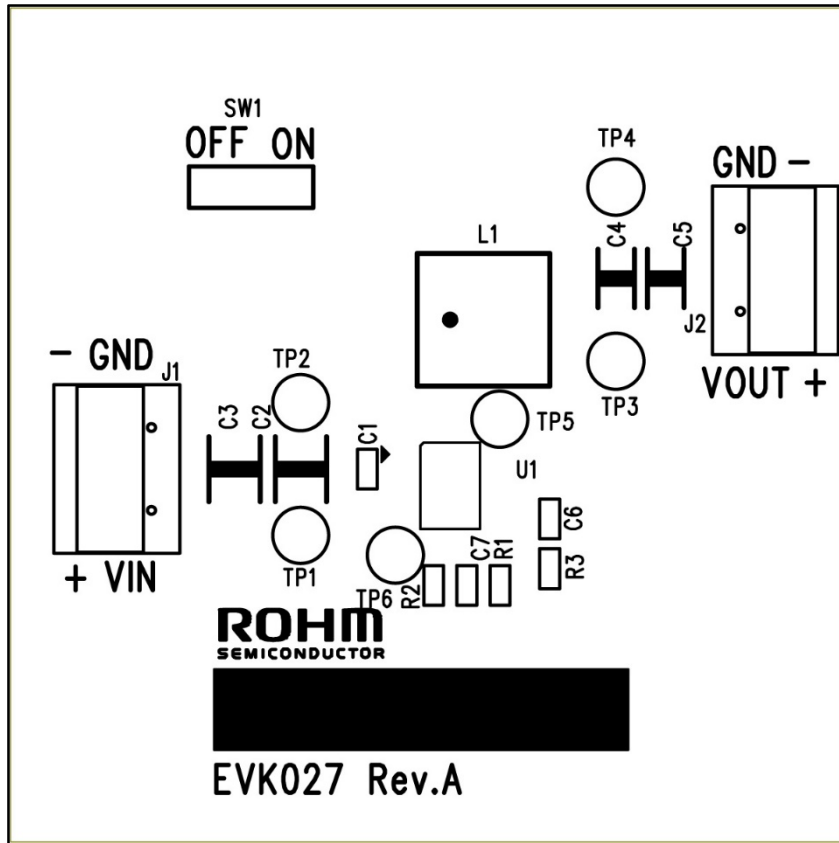

Figure 4. Top Silk Screen (Top view)

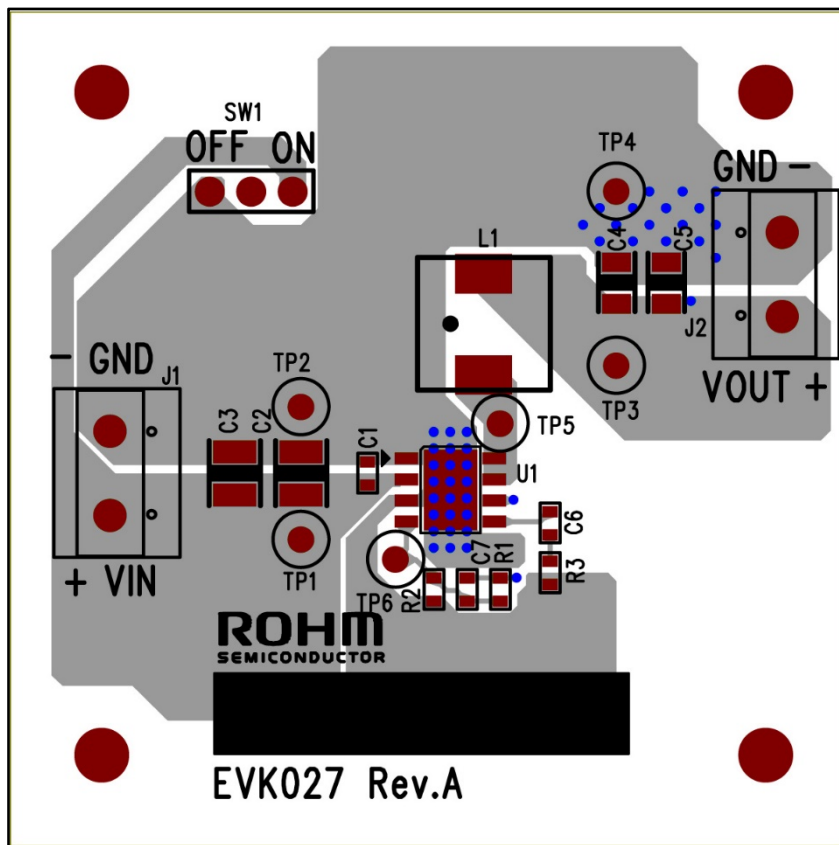

Figure 5. Top Silk Screen and Layout (Top view)

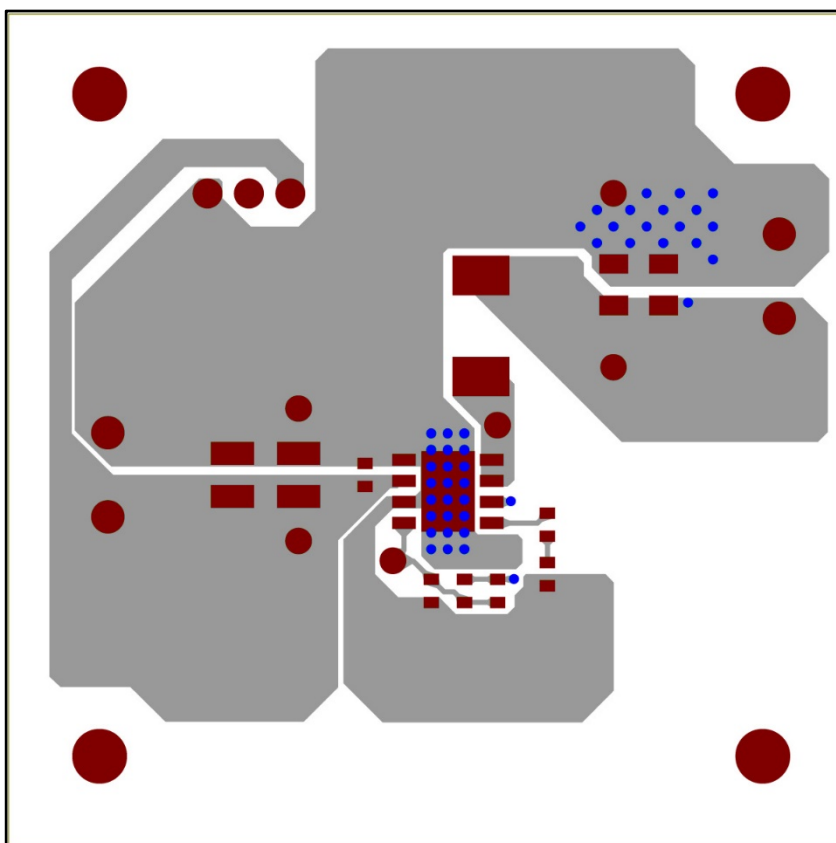

Figure 6. Top Side Layout (Top view)

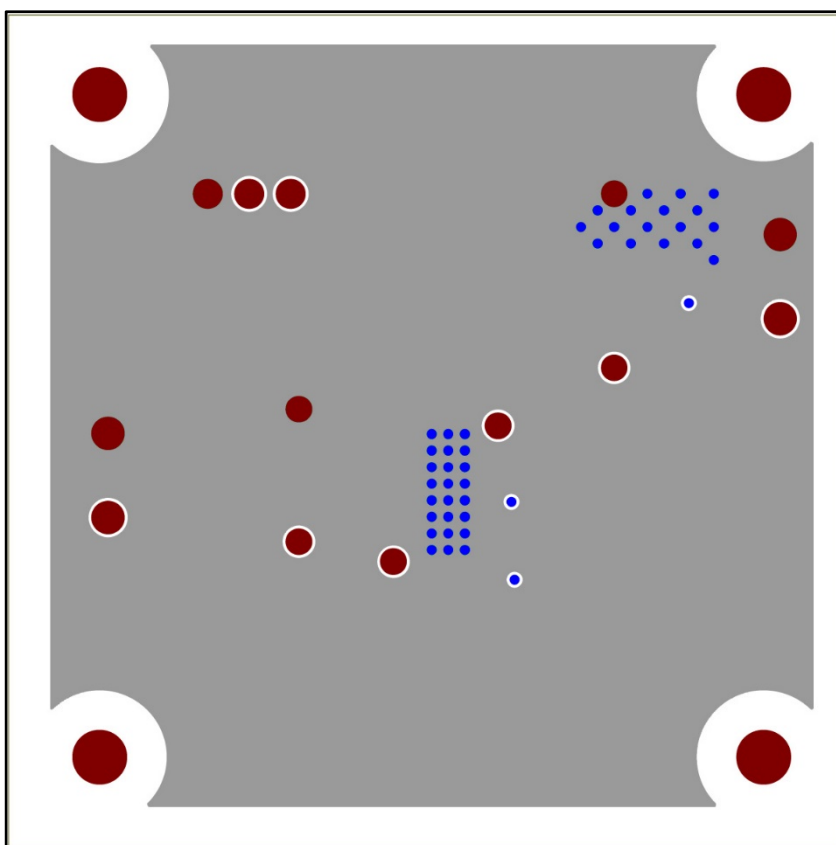

Figure 7. L2 Layout (Top view)

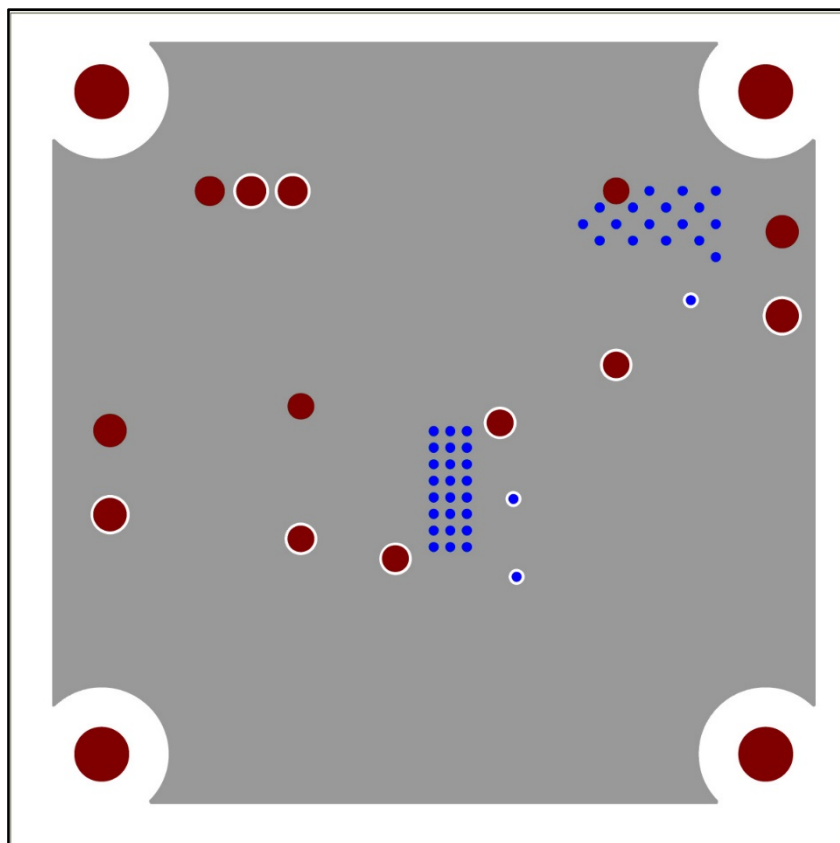

Figure 8. L3 Layout (Top view)

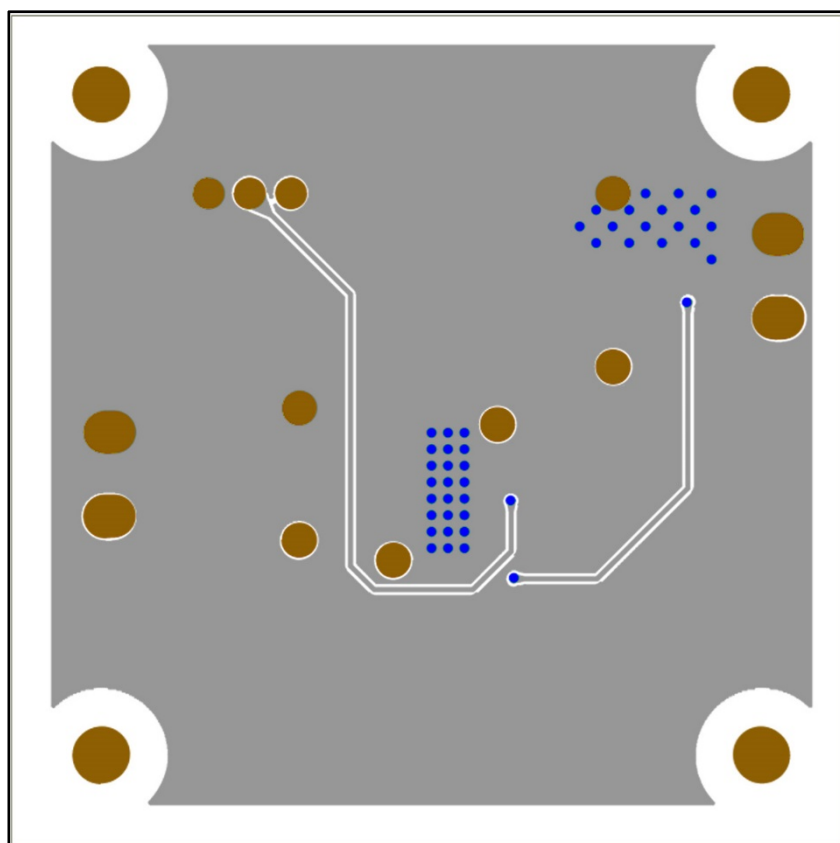

Figure 9. Bottom Side Layout (Top view)

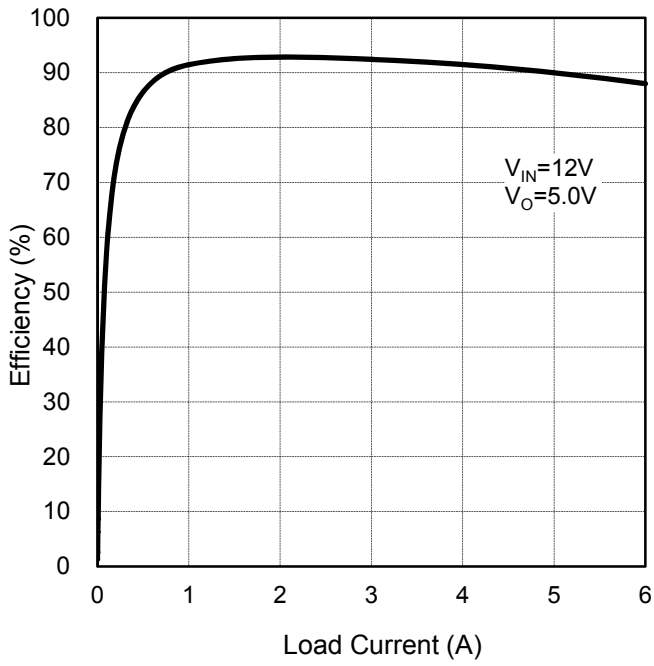

Figure 10. Efficiency vs Load Current

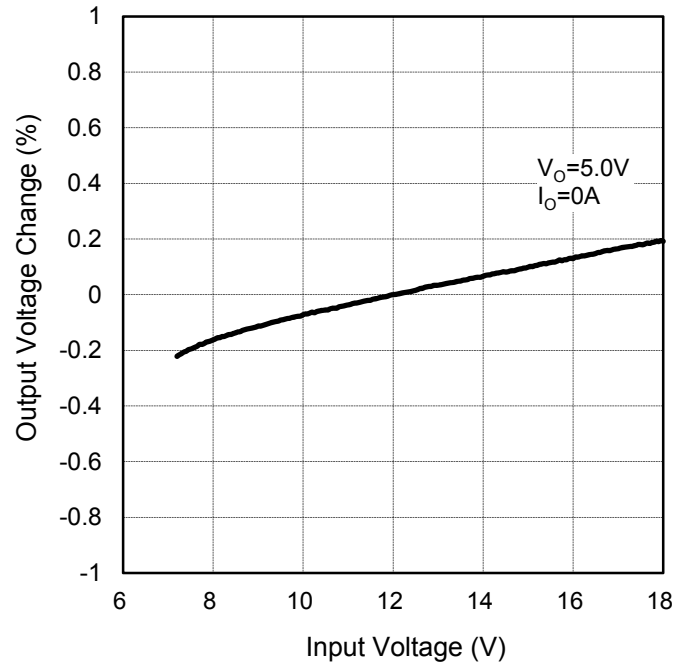

Figure 11. Efficiency vs Load Current

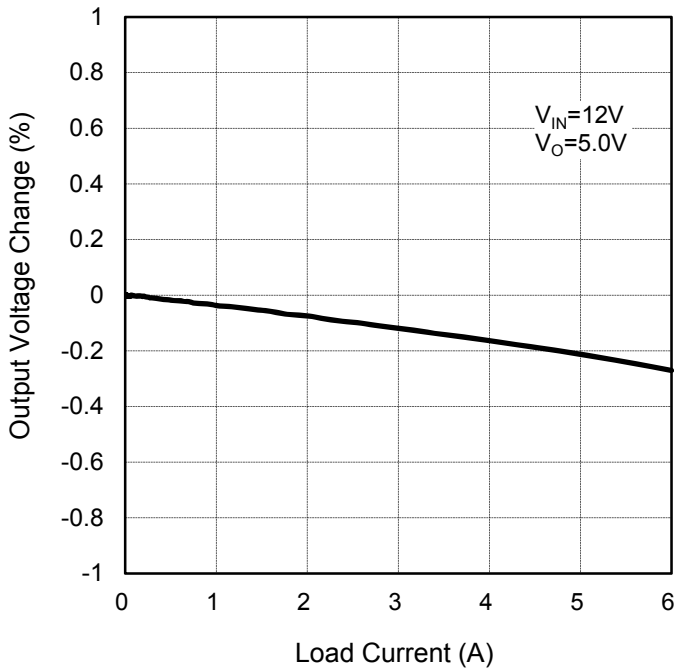

Figure 12. Load Regulation

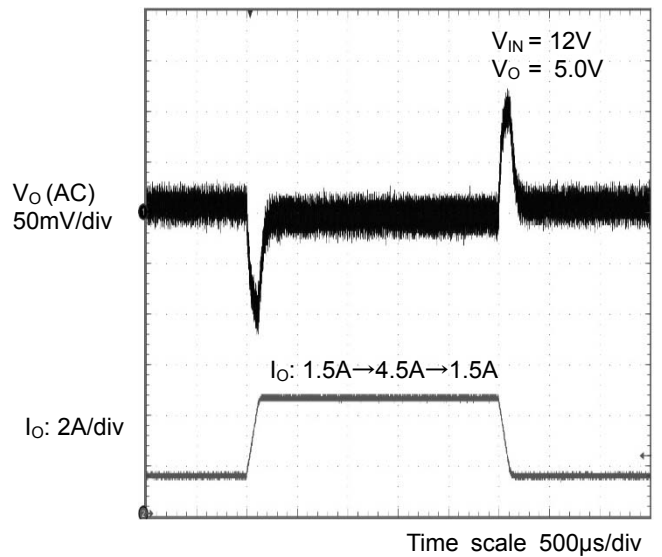

Figure 13. Load Transient Characteristics

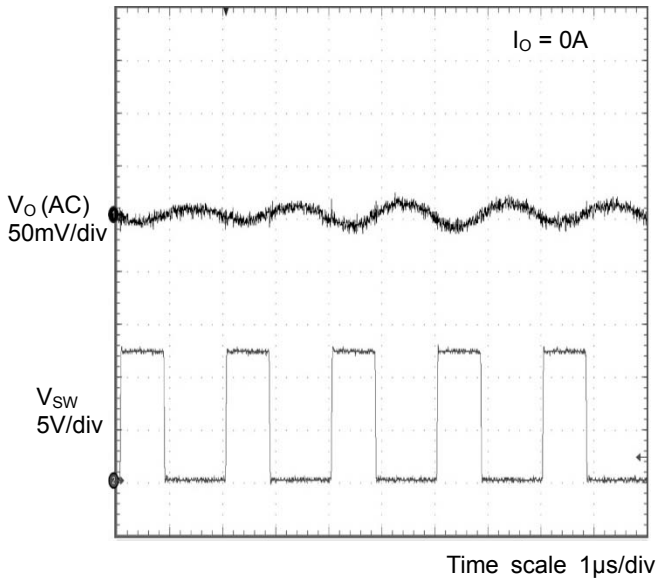

Figure 14. Output Voltage Ripple Wave
 $V_{IN} = 12V, V_O = 5.0V$

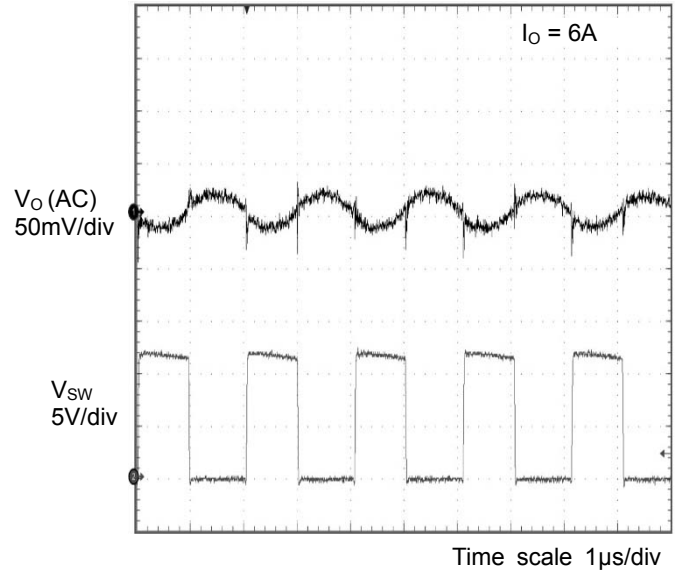

Figure 15. Output Voltage Ripple Wave
 $V_{IN} = 12V, V_O = 5.0V$

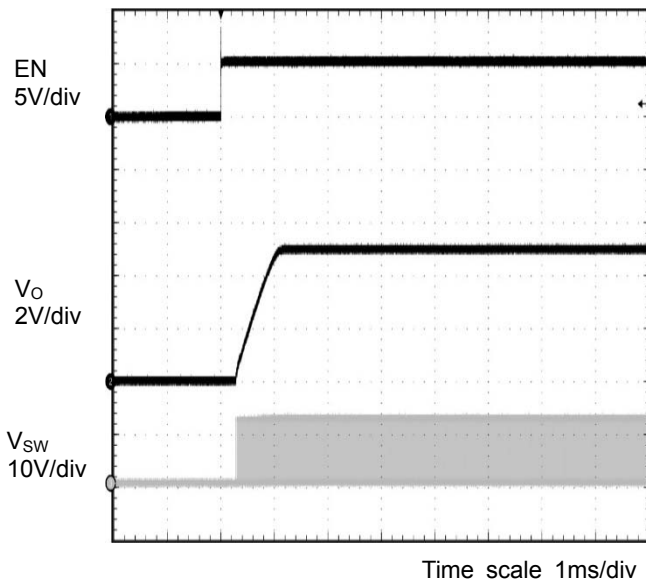

Figure 16. Start-up by EN
 $V_{IN} = 12V, V_O = 5.0V, I_o = 0A$

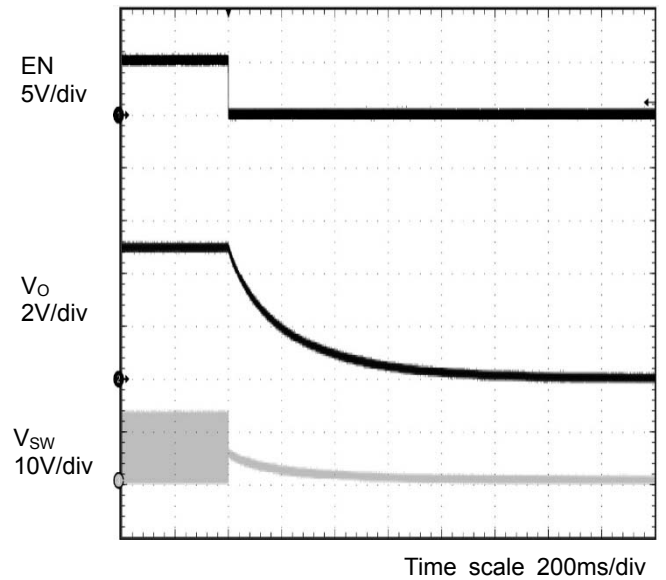

Figure 17. Power-down by EN
 $V_{IN} = 12V, V_O = 5.0V, I_o = 0A$

Notes

No copying or reproduction of this document, whole or in part, is permitted without the consent of ROHM Co., Ltd.

The contents specified herein are subject to change without notice.

The information contained in this document are for the purpose of introducing ROHM products (hereinafter "Products"). When using any such Products, please be sure to refer to the specifications, which can be obtained from ROHM upon request.

Examples of application circuits, circuit constants and any other information contained herein illustrate the standard usage and operation of the Products, and peripheral conditions must be taken into account when designing circuits for mass production.

Great care was taken in ensuring the accuracy of the information specified in this document. However, ROHM shall bear no responsibility for any damages incurred from inaccuracies or the misprint of information.

The technical information specified herein is intended only to show the typical functions and examples of application circuits for the Products. ROHM does not grant, either explicitly or implicitly, any license to use or exercise intellectual property or other rights held by ROHM and other parties. And ROHM shall bear no responsibility whatsoever for any disputes arising from the use of such technical information.

The Products specified in this document are intended to be used with general-use electronic equipment or devices (such as audio visual equipment, office automation equipment, communication devices, electronic appliances, and gaming systems).

The Products specified in this document are not designed to be radiation tolerant.

While ROHM makes every effort to enhance the quality and reliability of its Products, Products may fail or malfunction for a variety of reasons.

Please be sure to implement safety measures to guard against the possibility of physical injury, fire or any other damage that may arise due to Product failure, such as derating, redundancy, fire control and fail-safe designs. ROHM shall bear no responsibility whatsoever for the use of any Product outside of the prescribed scope or not in accordance with the instruction manual.

The Products are not designed or manufactured to be used with any equipment, device or system which requires an extremely high level of reliability, the failure or malfunction of which may result in a direct threat to human life or create a risk of human injury (such as a medical instruments, transportation equipment, aerospace machinery, nuclear reactor controllers, fuel controllers, or other safety device). ROHM shall bear no responsibility in any way for the use of any Products for the above special purposes. If a Product is to be used for any such special purpose, please contact a ROHM sales representative before purchasing.

If intending to export or ship overseas any Product or technology specified herein that is controlled under the Foreign Exchange and Foreign Trade Law it may be necessary to obtain a license or permit under the applicable law.



Thank you for your interest in ROHM products.
Please contact us for additional information or product catalogs.

ROHM Customer Support System

<http://www.rohm.com/contact/>

Mouser Electronics

Authorized Distributor

Click to View Pricing, Inventory, Delivery & Lifecycle Information:

[ROHM Semiconductor:](#)

[BD9C601EFJ-EVK-001](#)

Компания «Океан Электроники» предлагает заключение долгосрочных отношений при поставках импортных электронных компонентов на взаимовыгодных условиях!

Наши преимущества:

- Поставка оригинальных импортных электронных компонентов напрямую с производств Америки, Европы и Азии, а так же с крупнейших складов мира;
- Широкая линейка поставок активных и пассивных импортных электронных компонентов (более 30 млн. наименований);
- Поставка сложных, дефицитных, либо снятых с производства позиций;
- Оперативные сроки поставки под заказ (от 5 рабочих дней);
- Экспресс доставка в любую точку России;
- Помощь Конструкторского Отдела и консультации квалифицированных инженеров;
- Техническая поддержка проекта, помощь в подборе аналогов, поставка прототипов;
- Поставка электронных компонентов под контролем ВП;
- Система менеджмента качества сертифицирована по Международному стандарту ISO 9001;
- При необходимости вся продукция военного и аэрокосмического назначения проходит испытания и сертификацию в лаборатории (по согласованию с заказчиком);
- Поставка специализированных компонентов военного и аэрокосмического уровня качества (Xilinx, Altera, Analog Devices, Intersil, Interpoint, Microsemi, Actel, Aeroflex, Peregrine, VPT, Syfer, Eurofarad, Texas Instruments, MS Kennedy, Miteq, Cobham, E2V, MA-COM, Hittite, Mini-Circuits, General Dynamics и др.);

Компания «Океан Электроники» является официальным дистрибьютором и эксклюзивным представителем в России одного из крупнейших производителей разъемов военного и аэрокосмического назначения «JONHON», а так же официальным дистрибьютором и эксклюзивным представителем в России производителя высокотехнологичных и надежных решений для передачи СВЧ сигналов «FORSTAR».



JONHON

«JONHON» (основан в 1970 г.)

Разъемы специального, военного и аэрокосмического назначения:

(Применяются в военной, авиационной, аэрокосмической, морской, железнодорожной, горно- и нефтедобывающей отраслях промышленности)

«FORSTAR» (основан в 1998 г.)

ВЧ соединители, коаксиальные кабели, кабельные сборки и микроволновые компоненты:

(Применяются в телекоммуникациях гражданского и специального назначения, в средствах связи, РЛС, а так же военной, авиационной и аэрокосмической отраслях промышленности).



Телефон: 8 (812) 309-75-97 (многоканальный)

Факс: 8 (812) 320-03-32

Электронная почта: ocean@oceanchips.ru

Web: <http://oceanchips.ru/>

Адрес: 198099, г. Санкт-Петербург, ул. Калинина, д. 2, корп. 4, лит. А