



Connectors & Cable Assemblies Incorporating HDMI™ Technology

DESCRIPTION

Tyco Electronics' connector incorporating High-Definition Multimedia Interface (HDMI™) technology is an interface for consumer electronics products such as digital television, set-top boxes and DVD players. HDMI supports standard, enhanced, or high-definition video, plus multi-channel audio on a single cable.

APPLICATIONS

- Digital or High-Definition TV's
- Set-top Boxes
- Video Game Consoles
- DVD Players
- Desktop PC's

KEY FEATURES

- Simple User Friendly Connector
 - Replaces existing audio and digital cabling in one assembly
 - Easy-to-use friction lock design provides secure electrical contact and smooth cable insertion/extraction
- Full shielding for ESD protection and lead-free process available
- With or without panel flange
- 19 positions and 5 Gbps of bandwidth to support video and multi-channel audio in a single cable

MECHANICAL

- Durability: 10,000 cycles
- Mating Force: 9.9 lbs. [44.1 N] Max.
- Unmating Force: 2.2 lbs. [9.8] Min. 8.8 lbs. [39.2] Max.

TECHNICAL DOCUMENTS

- Meets Industry Standard High-Definition Multimedia Interface

CONNECTORS

Part Specifications

Product Number	PCB Mount Type	PCB Orientation	Number Of Ports	Packaging	(Dim A) Front Hold Down Legs	(Dim B) Back Hold Down Legs	Mounting Flange			(Dim E) PCB Profile Depth	Mating Finish
							Screw Size	(Dim C) CL of Mating Face to CL of Mounting Hole	(Dim D) Height (PCB- Top of Flange)		
1747981-1	SMT	R/A	1	Tape & Reel	1.8	2.2	-	-	-	11.55	A
1747981-2	SMT	R/A	1	Tape & Reel	1.5	1.5	-	-	-	11.55	A
1-1747981-1	SMT	R/A	1	Tray	1.8	2.2	M3 x 0.5	7.98	14.25	11.55	A
1-1747981-2	SMT	R/A	1	Tray	1.5	1.5	M3 x 0.5	7.98	14.25	11.55	A
1-1747981-3	SMT	R/A	1	Tray	1.8	2.2	4-40	10.08	16.05	11.55	A
1-1747981-4	SMT	R/A	1	Tray	1.8	2.2	M3 x 0.5	10.08	16.05	11.55	A
1-1747981-5	SMT	R/A	1	Tape & Reel	1.5	1.5	M3 x 0.5	7.98	14.25	11.55	A
2-1747981-3	SMT	R/A	1	Tape & Reel	1.8	2.2	M3 x 0.5	10.08	16.05	11.55	C
8-1747981-1	SMT	R/A	1	Tray	1.8	2.2	M3 x 0.5	7.98	14.25	11.55	A
1746679-1	T/H	R/A	1	Tray	1.8	2.2	M3 x 0.5	9.00	15.27	12.9	B
1903015-1	SMT	R/A	1	Tape & Reel	1.9	1.9	-	-	-	9.85	C
1903015-2	SMT	R/A	1	Tray	1.9	1.9	Ø2.65	9.00	15.40	9.85	C
1903015-3	SMT	R/A	1	Tape & Reel	1.9	1.9	M3 x 0.5	9.00	15.40	9.85	C
1903015-4	SMT	R/A	1	Tray	1.9	1.9	M3 x 0.5	9.00	15.40	9.85	C
5-1903015-1	SMT	R/A	1	Tape & Reel	1.9	1.9	-	-	-	9.85	B
5-1903015-2	SMT	R/A	1	Tray	1.9	1.9	Ø2.65	9.00	15.40	9.85	B
5-1903015-4	SMT	R/A	1	Tray	1.9	1.9	M3 x 0.5	9.00	15.40	9.85	B
1888811-1	T/H	R/A	2	Tray	2.1	2.1	M3 x 0.5	10.08	28.00	20.55	D
1888540-1	T/H	R/A	1*	Tray	1.8	2.2	M3 x 0.5	10.08	27.05	20.55	D
2007435-1	T/H	Flag	1	Tray	3.7	3.7	-	-	-	23.10	D

CL= Center Line

All dimensions in mm unless otherwise stated

Mating Finish - Gold or Gold Flash over Palladium Nickel

Mating Finish - **A** = Gold Flash over Palladium Nickel - **B** = 12µ Gold - **C** = 30µ Gold - **D** = Either A or B

*HDMI over E-SATA

Note: Part Numbers are RoHS Compliant.

2

HDMI is a trademark of HDMI Licensing L.L.C.
eSATA is a trademark of Wiebe Tech L.L.C.

PCB HEADER CONNECTORS - Product Dimensions & Part Numbers

Right Angle Surface Mount Header, No Flange (Long Body)

Part Numbers:

1747981-1
1747981-2

Product Specification:

108-78180-1

Qualification Test Report:

501-5640

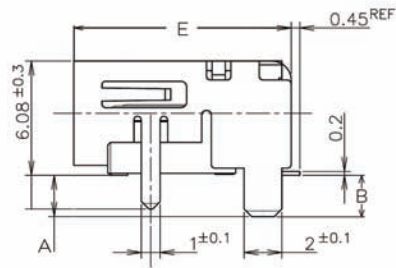
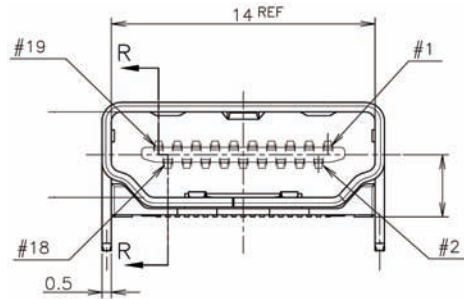
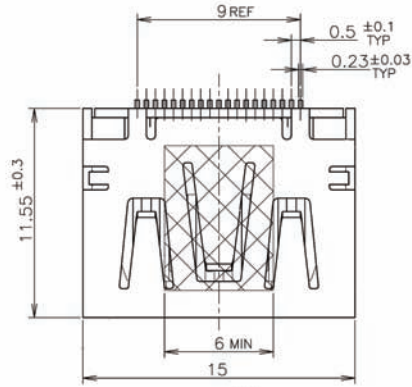

Right Angle Surface Mount Header with Flange (Long Body)

Part Numbers:

1-1747981-1
1-1747981-2
1-1747981-3
1-1747981-4
1-1747981-5
2-1747981-3
8-1747981-1

Product Specification:

108-78180-1

Qualification Test Report:

501-5640
501-5640-1

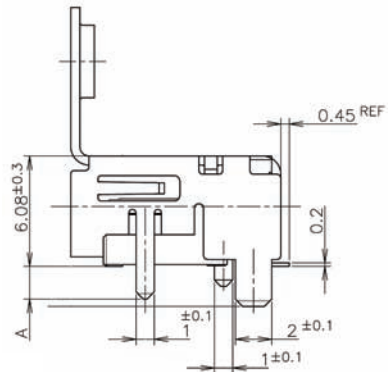
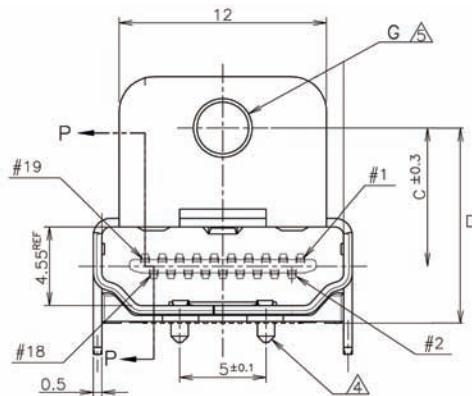
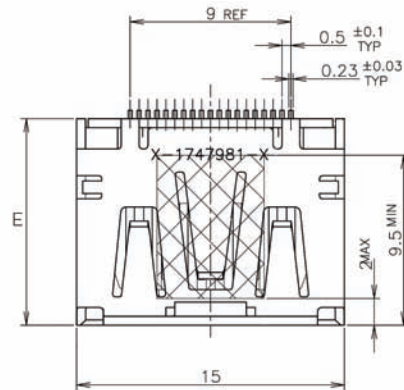

Note: Part Numbers are RoHS Compliant.

HDMI is a trademark of HDMI Licensing L.L.C.

PCB HEADER CONNECTORS - Product Dimensions & Part Numbers

Right Angle Surface Mount Header, No Flange (Short Body)

Part Numbers:

1903015-1
5-1903015-1

Product Specification:

108-78180-2

Qualification Test Report:

501-5640-2

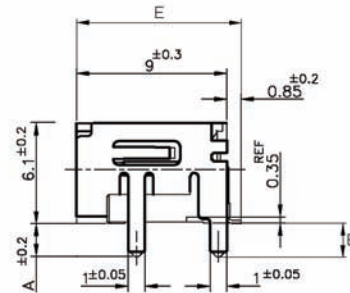
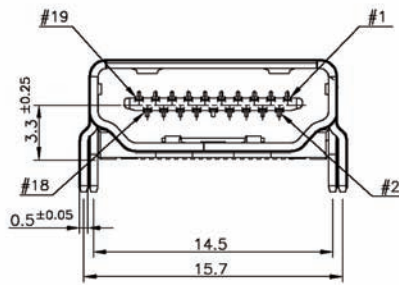
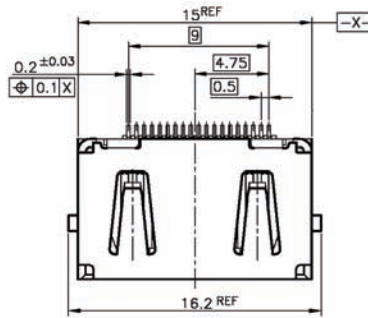

Right Angle Surface Mount Header with Flange (Short Body)

Part Numbers:

1903015-2
1903015-3
1903015-4
5-1903015-2
5-1903015-4

Product Specification:

108-78180-2

Qualification Test Report:

501-5640
501-5640-2
501-5841-2

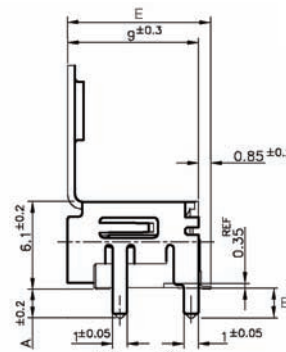
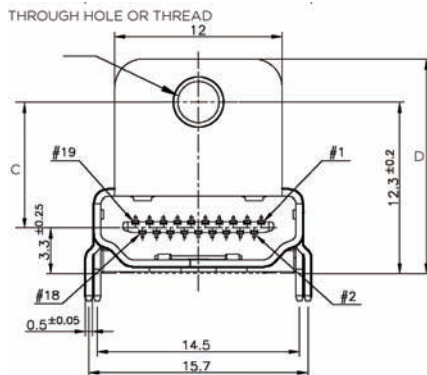
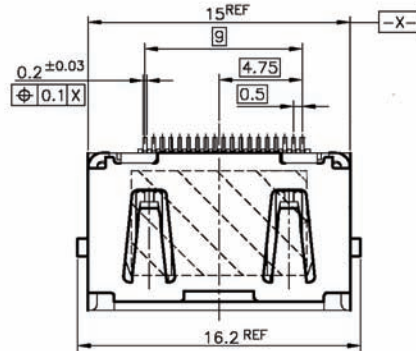

PCB HEADER CONNECTORS - Product Dimensions & Part Numbers

Right Angle Through Hole Header with Flange

Part Numbers:
1746679-1

Product Specification:
108-78180

Qualification Test Report:
501-5640

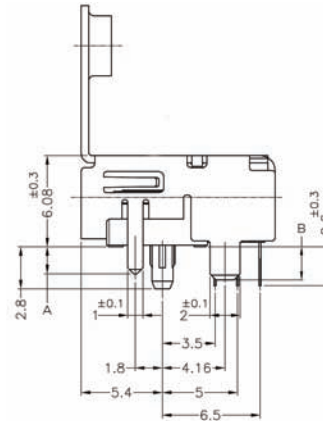
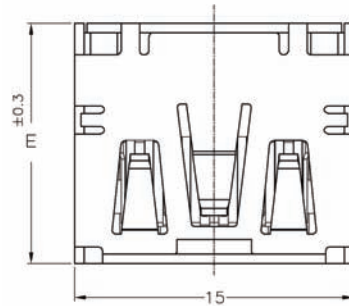
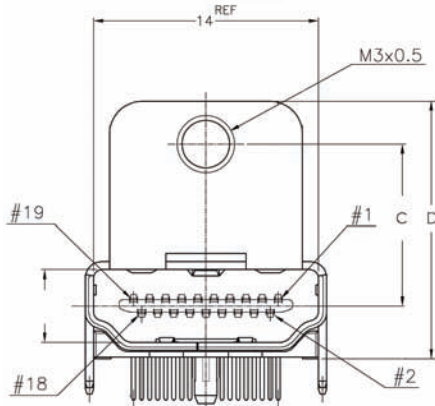

Flag Through Hole Header

Part Numbers:
2007435-1

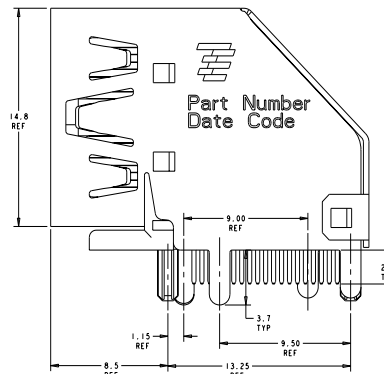
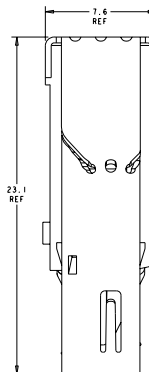
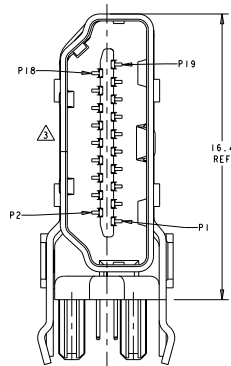

Stacked Right Angle Through Hole Header

Part Number:
1888540-1

Qualification Test Report:
501-662

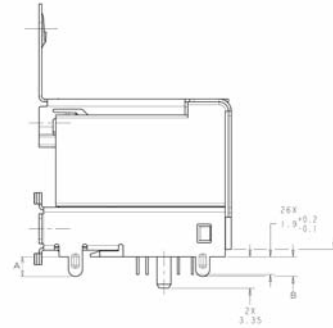
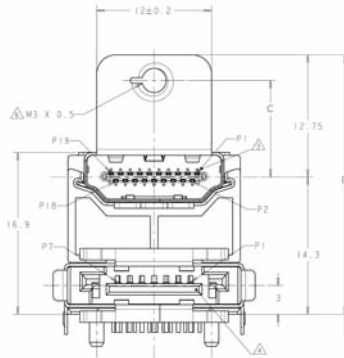
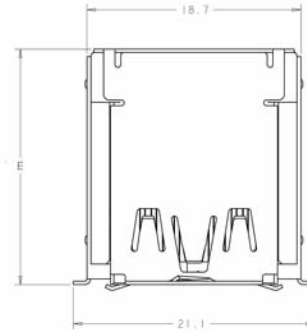

Stacked Right Angle Through Hole Incorporating HDMI Technology over eSATA Technology

Part Number:
1888811-1

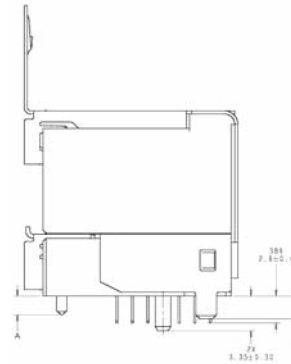
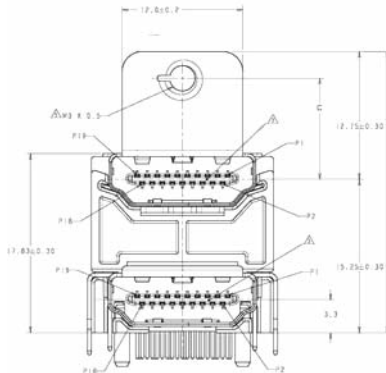
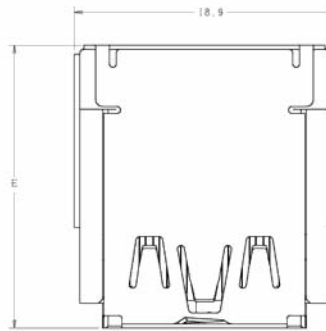

Note: Part Numbers are RoHS Compliant.

HDMI is a trademark of HDMI Licensing L.L.C.
eSATA is a trademark of Wiebe Tech L.L.C.

Connectors & Cable Assemblies Incorporating HDMI Technology

ELECTRICAL

- Voltage Rating: 40 VAC maximum
- Contact Current Rating: 0.5 A minimum
- Dry Circuit Resistance -
 Contacts: 30 mΩ maximum initial
 Shell: 50mΩ maximum initial
- Dielectric Withstanding Voltage -
 Unmated: 500 VAC
 Mated: 300 VAC
- Insulation Resistance -
 Unmated: 100 mΩ maximum
 Mated: 10 mΩ minimum

ENVIRONMENTAL

Temperature Range: -55°C to + 105

CABLE ASSEMBLY PART NUMBERS

Cable Assemblies Incorporating HDMI Technology to Cable Assemblies Incorporating HDMI Technology

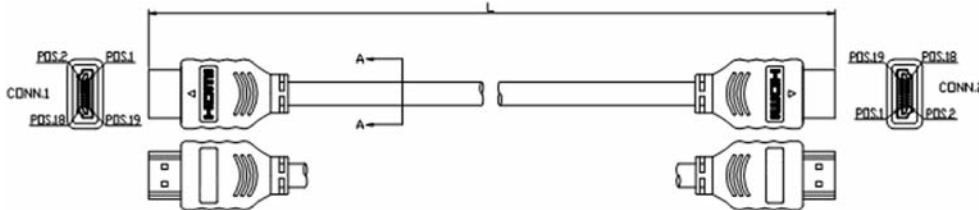

Dimension L	Part Number
1000 -20	1770019-6
750 -10	1770019-5
500 -10	1770019-4
250 -10	1770019-3
3000 -30	1770019-2
2000 -20	1770019-1

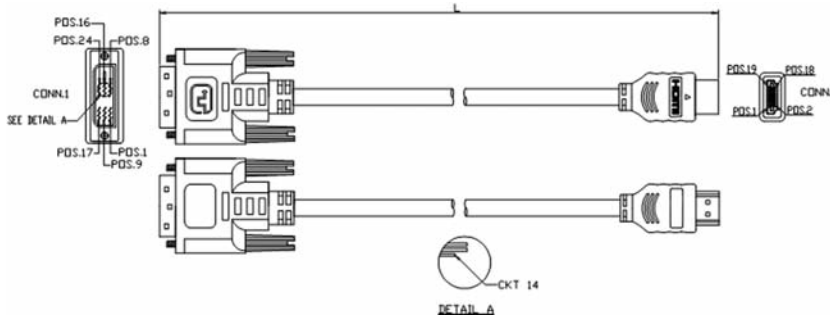

Dimension L	Part Number
1000 -20	1770020-6
750 -10	1770020-5
500 -10	1770020-4
250 -10	1770020-3
3000 -30	1770020-2
2000 -20	1770020-1

SHIELD	BRAID	SHELL	SHELL	SHELL	
C	BLUE	19	YES	19	YES
B	ORANGE	18	YES	18	YES
	YELLOW	17		17	
C	GREEN	16		16	
C	WHITE	15	YES	15	YES
C	VIOLET	14	YES	14	YES
C	RED	13		13	
	WHITE	12		12	
A	DRAIN WIRE	11	YES	11	YES
	GREEN	10	YES	10	YES
	WHITE	9		9	
A	DRAIN WIRE	8		8	
	GREEN	7	YES	7	YES
	WHITE	6	YES	6	YES
A	DRAIN WIRE	5		5	
	GREEN	4		4	
A	WHITE	3	YES	3	YES
A	DRAIN WIRE	2	YES	2	YES
	GREEN	1		1	
UNIT	WIRE COLOR	PIN	HST		HST
CABLE		CONN.1		CONN.2	

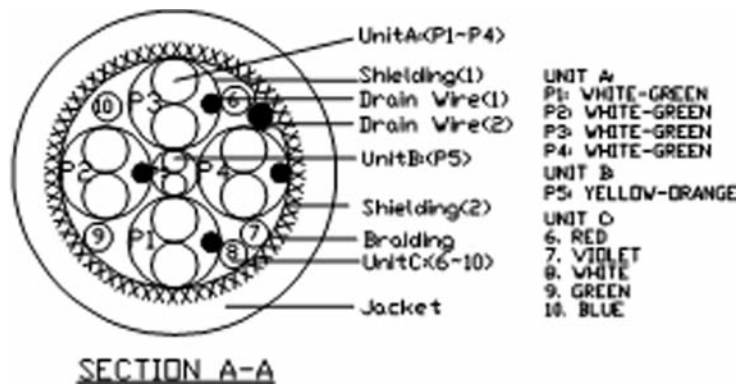

Note: Part Numbers are RoHS Compliant.

HDMI is a trademark of HDMI Licensing L.L.C.

FOR MORE INFORMATION

Connectors:

Americas

Eric Himelright, Product Manager

Phone: 717-986-3750

E-mail: elhimelright@tycoelectronics.com

EMEA

Pieter Groels, Product Manager

Phone: 73-624-6494

E-mail: p.groels@tycoelectronics.com

Asia

Paul Tsai, Product Manager

Phone: 755-2515-4774

E-mail: paul.tsai@tycoelectronics.com

Cable Assemblies:

Americas

John Montgomery, Product Manager

Phone: 717-986-3139

E-mail: monty@tycoelectronics.com

EMEA

Rob Smeets, Product Manager

Phone: 73-624-6327

E-mail: r.smeets@tycoelectronics.com

Asia

Jenny Pi, Product Manager

Phone: 2-87682788 ext. 882

E-mail: jenny.pi@tycoelectronics.com

Technical Support

Internet: <http://www.tycoelectronics.com>

<http://www.hdmi.org>

USA: 1-800-522-6752

Canada: 1-905-470-4425

UK: 44-141-810-8967

Japan: 81-44-844-8013

Restriction on the use of Hazardous Substances (RoHS)

At Tyco Electronics, we're ready to support your RoHS requirements. We've assessed more than 1.5 million end items/components for RoHS compliance, and issued new part numbers where any change was required to eliminate the restricted materials. Part numbers in this catalog are identified as:

RoHS Compliant — Part numbers in this catalog are RoHS Compliant, unless marked otherwise. These products comply with European Union Directive 2002/95/EC as amended 1 January 2006 that restricts the use of lead, mercury, cadmium, hexavalent chromium, PBB, and PBDE in certain electrical and electronic products sold into the EU as of 1 July 2006.

NOTE: For purposes of this Catalog, included within the definition of RoHS Compliant are products that are clearly "Out of Scope" of the RoHS Directive such as hand tools and other non-electrical accessories.

NOTE: Information regarding RoHS compliance is provided based on reasonable inquiry of our suppliers and represents our current actual knowledge based on the information provided by our suppliers. This information is subject to change. For latest compliance status, refer to our website referenced at right.

Getting the Information You Need

Our comprehensive on-line RoHS Customer Support Center provides a forum to answer your questions and support your RoHS needs. A RoHS FAQ (Frequently Asked Questions) is available with links to more detailed information. You can also submit RoHS questions and receive a response within 24 hours during a normal work week.

The Support Center also provides:

- Cross-Reference from Non-compliant to Compliant Products
- Ability to browse RoHS Compliant Products in our on-line catalog
- Downloadable Technical Data Customer Information Presentation
- More detailed information regarding the definitions used above
- So whatever your questions when it comes to RoHS, we've got the answers at www.tycoelectronics.com/leadfree



Disclaimer

While Tyco Electronics Corporation and its affiliates referenced herein ("Tyco Electronics") have made every reasonable effort to ensure the accuracy of the information in this catalog, Tyco Electronics does not guarantee that it is error free, nor does Tyco Electronics make any other representation, warranty or guarantee that the information is accurate, correct reliable or current.

Tyco Electronics reserves the right to make any adjustments to the information contained herein at any time without notice. Tyco Electronics expressly disclaims all implied warranties regarding the information contained herein, including, but not limited to, any implied warranties of merchantability or fitness for a particular purpose. Tyco Electronics' only obligations are those in the Tyco Electronics Standard Terms and Conditions of Sale, and in no case will Tyco Electronics be responsible for any incidental, indirect, or consequential damages arising from the sale, resale, or misuse of its products. Users should independently evaluate the suitability of, and test each product for, their application.

Компания «Океан Электроники» предлагает заключение долгосрочных отношений при поставках импортных электронных компонентов на взаимовыгодных условиях!

Наши преимущества:

- Поставка оригинальных импортных электронных компонентов напрямую с производств Америки, Европы и Азии, а так же с крупнейших складов мира;
- Широкая линейка поставок активных и пассивных импортных электронных компонентов (более 30 млн. наименований);
- Поставка сложных, дефицитных, либо снятых с производства позиций;
- Оперативные сроки поставки под заказ (от 5 рабочих дней);
- Экспресс доставка в любую точку России;
- Помощь Конструкторского Отдела и консультации квалифицированных инженеров;
- Техническая поддержка проекта, помощь в подборе аналогов, поставка прототипов;
- Поставка электронных компонентов под контролем ВП;
- Система менеджмента качества сертифицирована по Международному стандарту ISO 9001;
- При необходимости вся продукция военного и аэрокосмического назначения проходит испытания и сертификацию в лаборатории (по согласованию с заказчиком);
- Поставка специализированных компонентов военного и аэрокосмического уровня качества (Xilinx, Altera, Analog Devices, Intersil, Interpoint, Microsemi, Actel, Aeroflex, Peregrine, VPT, Syfer, Eurofarad, Texas Instruments, MS Kennedy, Miteq, Cobham, E2V, MA-COM, Hittite, Mini-Circuits, General Dynamics и др.);

Компания «Океан Электроники» является официальным дистрибьютором и эксклюзивным представителем в России одного из крупнейших производителей разъемов военного и аэрокосмического назначения «**JONHON**», а так же официальным дистрибьютором и эксклюзивным представителем в России производителя высокотехнологичных и надежных решений для передачи СВЧ сигналов «**FORSTAR**».



JONHON

«**JONHON**» (основан в 1970 г.)

Разъемы специального, военного и аэрокосмического назначения:

(Применяются в военной, авиационной, аэрокосмической, морской, железнодорожной, горно- и нефтедобывающей отраслях промышленности)

«**FORSTAR**» (основан в 1998 г.)

ВЧ соединители, коаксиальные кабели,
кабельные сборки и микроволновые компоненты:

(Применяются в телекоммуникациях гражданского и специального назначения, в средствах связи, РЛС, а так же военной, авиационной и аэрокосмической отраслях промышленности).



Телефон: 8 (812) 309-75-97 (многоканальный)

Факс: 8 (812) 320-03-32

Электронная почта: ocean@oceanchips.ru

Web: <http://oceanchips.ru/>

Адрес: 198099, г. Санкт-Петербург, ул. Калинина, д. 2, корп. 4, лит. А