

Power Resistor for Mounting onto a Heatsink Thick Film Technology



FEATURES

- 800 W at 85 °C bottom case temperature
- Wide resistance range: 0.3 Ω to 900 kΩ E24 series
- Non inductive
- Easy mounting
- Low thermal radiation of the case
- Material categorization: For definitions of compliance please see www.vishay.com/doc?99912

RoHS
COMPLIANT

DIMENSIONS in millimeters

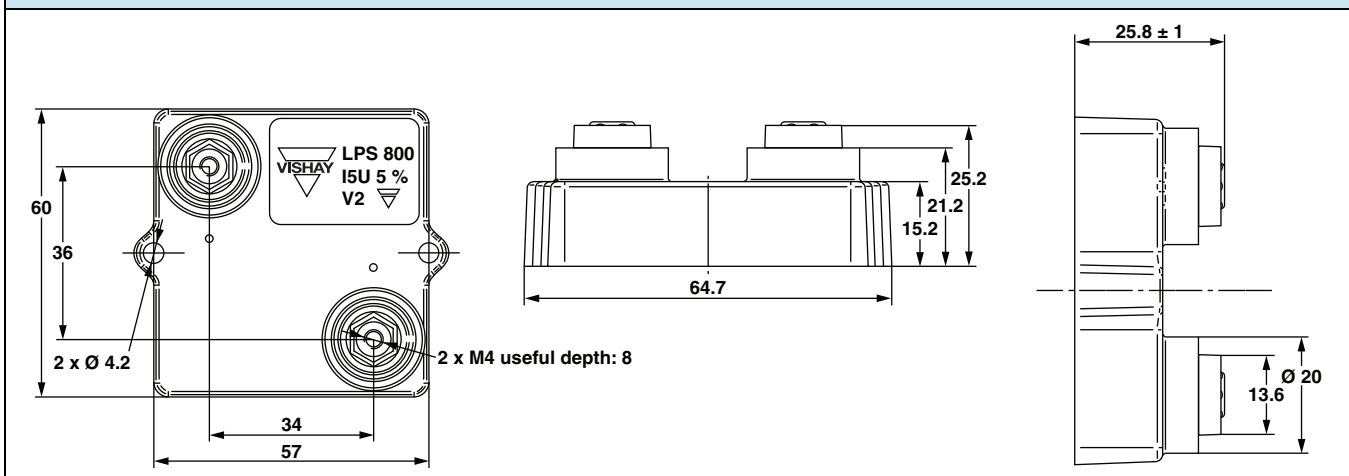

Note

- Tolerances unless stated: ± 0.2 mm

STANDARD ELECTRICAL SPECIFICATIONS

| MODEL | RESISTANCE RANGE Ω | RATED POWER $P_{85^{\circ}\text{C}}$ W | LIMITING ELEMENT VOLTAGE U_L V | TOLERANCE ± % | TEMPERATURE COEFFICIENT ± ppm/°C | CRITICAL RESISTANCE (Ω) |
|---------|-----------------------|--|-------------------------------------|------------------|-------------------------------------|-------------------------|
| LPS 800 | 0.3 to 900K | 800 | 5K | 1, 2, 5, 10 | 150, 300, 500 | 31.25K |

MECHANICAL SPECIFICATIONS

| | |
|-------------------------------|--------------------------|
| Mechanical Protection | Insulated case UL 94 V-0 |
| Resistive Element | Thick film |
| Substrate | Alumina |
| End Connections | Screws M4 |
| Tightening Torque Connections | 2 Nm |
| Tightening Torque Heatsink | 2 Nm |
| Maximum Torque | 2.5 Nm |
| Weight | 83 g ± 10 % |

TECHNICAL SPECIFICATIONS

| | |
|--|--|
| Power Rating and Thermal Resistance | 800 W at + 85 °C bottom case temperature $R_{TH(j-c)}$: 0.112 °C/W |
| Temperature Coefficient - 55 °C/175 °C IEC 60115-1 Standard | $R \leq 1 \Omega$: ± 500 ppm/°C $1 \Omega < R \leq 10 \Omega$: ± 300 ppm/°C $10 \Omega < R$: ± 150 ppm/°C |
| Dielectric Strength IEC 60115-1, 1 min, 10 mA max. | 7 kV _{RMS} or 12 kV _{RMS} |
| Insulation Resistance | ≥ 10 ⁴ MΩ |
| Inductance | ≤ 0.1 μH |

ENVIRONMENTAL SPECIFICATIONS

| | |
|-------------------|-------------------|
| Temperature Range | - 55 °C to 175 °C |
| Climatic Category | 55/175/56 |



| PERFORMANCE | | |
|--------------------------|--|---------------------|
| TESTS | CONDITIONS | REQUIREMENTS |
| Momentary Overload | IEC 60115-1 1.5 x P _r /10 s U _{max.} ≤ U _L = 5000 V | ± (0.25 % + 0.05 Ω) |
| Rapid Temperature Change | IEC 60115-1/IEC 30068-2-14 Test Na 50 cycles - 55 °C to + 175 °C | ± (0.5 % + 0.05 Ω) |
| Load Life | IEC 60115-1 1000 h (90/30) P _r at 85 °C | ± (0.5 % + 0.05 Ω) |
| Humidity (Steady State) | IEC 60115-1 56 days RH 95 %/40 °C | ± (0.5 % + 0.05 Ω) |
| Vibration | MIL STD 202 method 204 cond. D (10 g; 5/500 Hz) | ± (0.25 % + 0.05 Ω) |
| Climatic Sequence | IEC 60115-1 (55/175/56) | ± (1 % + 0.05 Ω) |

RECOMMENDATIONS FOR MOUNTING ONTO A HEATSINK

- Surfaces in contact must be carefully cleaned.
- The heatsink must have an acceptable flatness: From 0.05 mm to 0.1 mm/100 mm.
- Roughness of the heatsink must be around 6.3 μm. In order to improve thermal conductivity, surfaces in contact (alumina, heatsink) should be coated with a silicone grease (type SI 340 from Rhône-Poulenc or Dow 340 from Dow Corning) or a thermal film (type Q Pad II) easier and faster to install than the grease.
- The fastening of the resistor to the heatsink is under pressure control of two screws tightened at 2 Nm for full power availability.

| | |
|-------------------------------|---------|
| Tightening Torque on Heatsink | LPS 800 |
| | 2 Nm |

- The following accessories are supplied with each product:
 - 2 screws CHC M4 x 25 class 8.8 and 2 M4 contact lock washers for heatsink mounting
 - 2 screws TH M4 x 6/6 and 2 M4 contact lock washers for connections.

CHOICE OF THE HEATSINK

The user must choose the heatsink according to the working conditions of the component (power, room temperature). Maximum working temperature must not exceed 175 °C. The dissipated power is simply calculated by the following ratio:

$$P = \frac{\Delta T}{[R_{TH(j-c)} + R_{TH(c-a)}]}$$

- P: Expressed in W
- ΔT: Difference between maximum working temperature and room temperature
- R_{TH(j-c)}: Thermal resistance value measured between resistive layer and outer side of the resistor. It is the thermal resistance of the component: (see specifications environmental paragraph).
- R_{TH(c-a)}: Thermal resistance value measured between outer side of the resistor and room temperature. It is the thermal resistance of the thermal interface, the heatsink (type, shape) and the quality of the fastening device.

Example:

R_{TH(c-a)} for LPS 800 power dissipation 180 W at + 50 °C room temperature.

$$\Delta T \leq 175 \text{ °C} - 50 \text{ °C} = 125 \text{ °C}$$

$$R_{TH(j-c)} + R_{TH(c-a)} = \frac{\Delta T}{P} = \frac{125}{180} = 0.69 \text{ °C/W}$$

$$R_{TH(j-c)} = 0.112 \text{ °C/W}$$

$$R_{TH(c-a)} = 0.69 \text{ °C/W} - 0.112 \text{ °C/W} = 0.578 \text{ °C/W}$$

| | CONFIG. 1: WATER COOLING HEATSINK CP15 AND THERMAL GREASE SI340 | CONFIG. 2: AIR COOLING HEATSINK P207/250 AND THERMAL GREASE SI340 | CONFIG. 3: WATER COOLING HEATSINK CP15 AND THERMAL PAD Q-PAD II | CONFIG. 4: AIR COOLING HEATSINK P207/250 AND THERMAL PAD Q-PAD II |
|---------------------------|---|---|---|---|
| Power dissipation (W) | 710 | 282 | 307 | 180 |
| T° resistive element (°C) | 175 | 175 | 175 | 175 |
| $R_{TH(j-c)}$ max. (°C/W) | 0.112 | 0.112 | 0.112 | 0.112 |
| $R_{TH(c-h)}$ typ. (°C/W) | 0.05 | 0.13 | 0.34 | 0.43 |
| $R_{TH(h-a)}$ max. (°C/W) | 0.059 | 0.29 | 0.059 | 0.29 |
| Fluid T° (°C) | 18 | 25 | 18 | 25 |

Notes

- **Configuration 1:** Water cooling heatsink CP15 from Lytron (304 mm x 95.3 mm x 8 mm) with water flow rate 4 LPM and thermal grease SI340 from BlueStar silicones.
- **Configuration 2:** Air cooling heatsink P207/250 from Semikron (250 mm x 200 mm x 72 mm) and thermal grease SI340 from BlueStar silicones.
- **Configuration 3:** Water cooling heatsink CP15 from Lytron (304 mm x 95.3 mm x 8 mm) with water flow rate 4 LPM and thermal pad Q-Pad II from Berquist.
- **Configuration 4:** Air cooling heatsink P207/250 from Semikron (250 mm x 200 mm x 72 mm) and thermal pad Q-Pad II from Berquist.

OVERLOADS

In any case the applied voltage must be lower than $U_L = 5000$ V.

Short time overload: $1.5 \times P_r / 10$ s

Accidental overload: The values indicated on the following graph are applicable to resistors in air or mounted onto a heatsink.

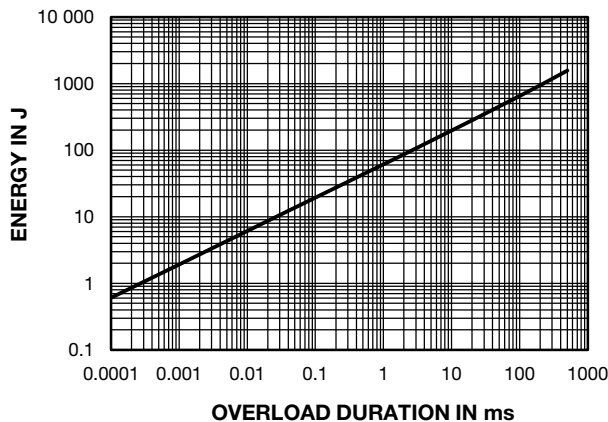
ENERGY CURVE

POWER RATING

The temperature of the case should be maintained within the limits specified in the following figure.

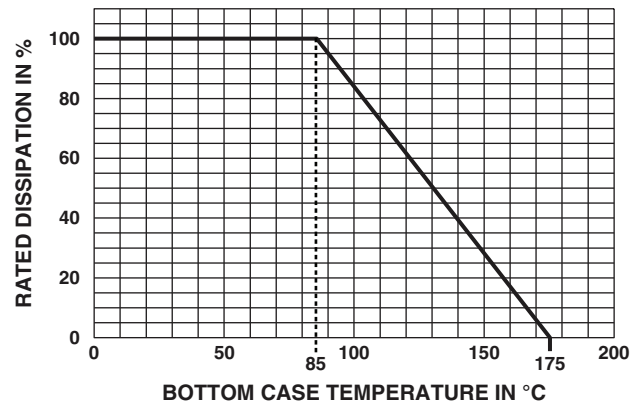
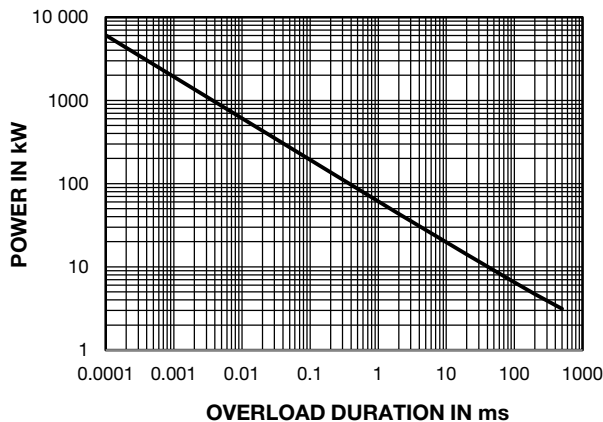
To optimize the thermal conduction, contacting surfaces should be coated with silicone grease or thermal film, and heatsink mounting screws tightened to 2 Nm.

POWER CURVE

MARKING

Series, style, ohmic value (in Ω), tolerance (in %), manufacturing date, Vishay Sfernice trademark.

PACKAGING

Box of 15 units



| ORDERING INFORMATION | | | | | | |
|----------------------|-------|------------------|-----------------------------------|---|-----------|----------------|
| LPS | 800 | 100 kΩ | ± 1 % | xxx | BO15 | e |
| MODEL | STYLE | RESISTANCE VALUE | TOLERANCE | CUSTOM DESIGN | PACKAGING | LEAD (Pb)-FREE |
| | | | ± 1 % ± 2 % ± 5 % ± 10 % | Optional on request: Special TCR, shape etc. | | |

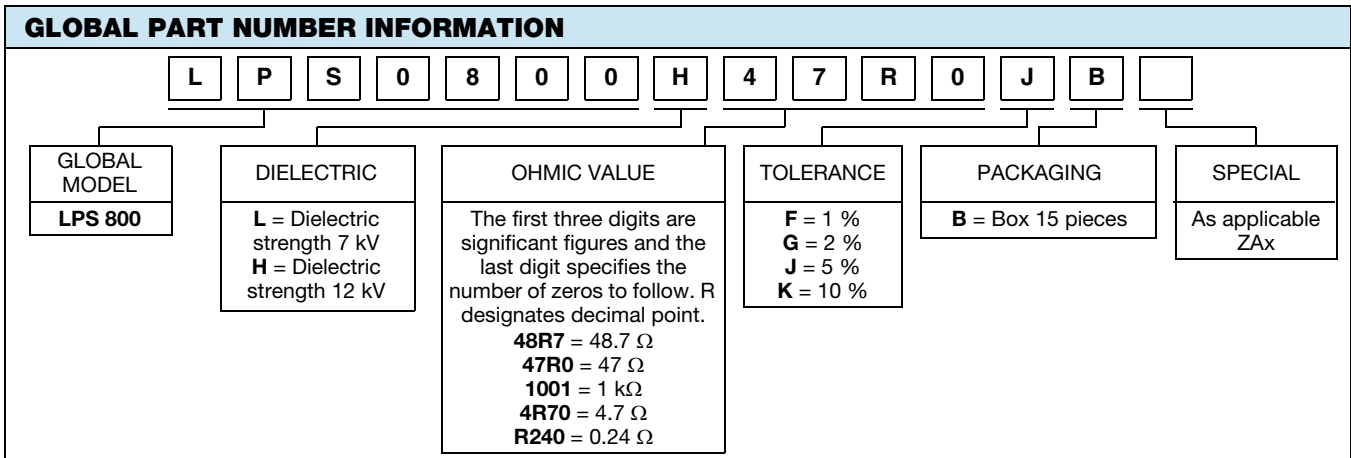



Disclaimer

ALL PRODUCT, PRODUCT SPECIFICATIONS AND DATA ARE SUBJECT TO CHANGE WITHOUT NOTICE TO IMPROVE RELIABILITY, FUNCTION OR DESIGN OR OTHERWISE.

Vishay Intertechnology, Inc., its affiliates, agents, and employees, and all persons acting on its or their behalf (collectively, "Vishay"), disclaim any and all liability for any errors, inaccuracies or incompleteness contained in any datasheet or in any other disclosure relating to any product.

Vishay makes no warranty, representation or guarantee regarding the suitability of the products for any particular purpose or the continuing production of any product. To the maximum extent permitted by applicable law, Vishay disclaims (i) any and all liability arising out of the application or use of any product, (ii) any and all liability, including without limitation special, consequential or incidental damages, and (iii) any and all implied warranties, including warranties of fitness for particular purpose, non-infringement and merchantability.

Statements regarding the suitability of products for certain types of applications are based on Vishay's knowledge of typical requirements that are often placed on Vishay products in generic applications. Such statements are not binding statements about the suitability of products for a particular application. It is the customer's responsibility to validate that a particular product with the properties described in the product specification is suitable for use in a particular application. Parameters provided in datasheets and/or specifications may vary in different applications and performance may vary over time. All operating parameters, including typical parameters, must be validated for each customer application by the customer's technical experts. Product specifications do not expand or otherwise modify Vishay's terms and conditions of purchase, including but not limited to the warranty expressed therein.

Except as expressly indicated in writing, Vishay products are not designed for use in medical, life-saving, or life-sustaining applications or for any other application in which the failure of the Vishay product could result in personal injury or death. Customers using or selling Vishay products not expressly indicated for use in such applications do so at their own risk. Please contact authorized Vishay personnel to obtain written terms and conditions regarding products designed for such applications.

No license, express or implied, by estoppel or otherwise, to any intellectual property rights is granted by this document or by any conduct of Vishay. Product names and markings noted herein may be trademarks of their respective owners.

Material Category Policy

Vishay Intertechnology, Inc. hereby certifies that all its products that are identified as RoHS-Compliant fulfill the definitions and restrictions defined under Directive 2011/65/EU of The European Parliament and of the Council of June 8, 2011 on the restriction of the use of certain hazardous substances in electrical and electronic equipment (EEE) - recast, unless otherwise specified as non-compliant.

Please note that some Vishay documentation may still make reference to RoHS Directive 2002/95/EC. We confirm that all the products identified as being compliant to Directive 2002/95/EC conform to Directive 2011/65/EU.

Vishay Intertechnology, Inc. hereby certifies that all its products that are identified as Halogen-Free follow Halogen-Free requirements as per JEDEC JS709A standards. Please note that some Vishay documentation may still make reference to the IEC 61249-2-21 definition. We confirm that all the products identified as being compliant to IEC 61249-2-21 conform to JEDEC JS709A standards.

Компания «Океан Электроники» предлагает заключение долгосрочных отношений при поставках импортных электронных компонентов на взаимовыгодных условиях!

Наши преимущества:

- Поставка оригинальных импортных электронных компонентов напрямую с производств Америки, Европы и Азии, а так же с крупнейших складов мира;
- Широкая линейка поставок активных и пассивных импортных электронных компонентов (более 30 млн. наименований);
- Поставка сложных, дефицитных, либо снятых с производства позиций;
- Оперативные сроки поставки под заказ (от 5 рабочих дней);
- Экспресс доставка в любую точку России;
- Помощь Конструкторского Отдела и консультации квалифицированных инженеров;
- Техническая поддержка проекта, помощь в подборе аналогов, поставка прототипов;
- Поставка электронных компонентов под контролем ВП;
- Система менеджмента качества сертифицирована по Международному стандарту ISO 9001;
- При необходимости вся продукция военного и аэрокосмического назначения проходит испытания и сертификацию в лаборатории (по согласованию с заказчиком);
- Поставка специализированных компонентов военного и аэрокосмического уровня качества (Xilinx, Altera, Analog Devices, Intersil, Interpoint, Microsemi, Actel, Aeroflex, Peregrine, VPT, Syfer, Eurofarad, Texas Instruments, MS Kennedy, Miteq, Cobham, E2V, MA-COM, Hittite, Mini-Circuits, General Dynamics и др.);

Компания «Океан Электроники» является официальным дистрибьютором и эксклюзивным представителем в России одного из крупнейших производителей разъемов военного и аэрокосмического назначения «JONHON», а так же официальным дистрибьютором и эксклюзивным представителем в России производителя высокотехнологичных и надежных решений для передачи СВЧ сигналов «FORSTAR».



JONHON

«JONHON» (основан в 1970 г.)

Разъемы специального, военного и аэрокосмического назначения:

(Применяются в военной, авиационной, аэрокосмической, морской, железнодорожной, горно- и нефтедобывающей отраслях промышленности)

«FORSTAR» (основан в 1998 г.)

ВЧ соединители, коаксиальные кабели, кабельные сборки и микроволновые компоненты:

(Применяются в телекоммуникациях гражданского и специального назначения, в средствах связи, РЛС, а так же военной, авиационной и аэрокосмической отраслях промышленности).



Телефон: 8 (812) 309-75-97 (многоканальный)

Факс: 8 (812) 320-03-32

Электронная почта: ocean@oceanchips.ru

Web: <http://oceanchips.ru/>

Адрес: 198099, г. Санкт-Петербург, ул. Калинина, д. 2, корп. 4, лит. А