

NBSG16M

2.5 V/3.3 V Multilevel Input to CML Clock/Data Receiver/Driver/Translator Buffer

Description

The NBSG16M is a differential current mode logic (CML) receiver/driver/translator buffer. The device is functionally equivalent to the EP16, LVEP16, or SG16 devices with CML output structure and lower EMI capabilities.

Inputs incorporate internal 50 Ω termination resistors and accept LVNECL (Negative ECL), LVPECL (Positive ECL), LVTTTL, LVCMOS, CML, or LVDS. The CML output structure contains internal 50 Ω source termination resistor to V_{CC} . The device generates 400 mV output amplitude with 50 Ω receiver resistor to V_{CC} .

The V_{BB} pin is internally generated voltage supply available to this device only. For all single-ended input conditions, the unused complementary differential input is connected to V_{BB} as a switching reference voltage. V_{BB} may also rebias AC coupled inputs. When used, decouple V_{BB} via a 0.01 μ F capacitor and limit current sourcing or sinking to 0.5 mA. When not used, V_{BB} output should be left open.

Features

- Maximum Input Clock Frequency > 10 GHz Typical
- Maximum Input Data Rate > 10 Gb/s Typical
- 120 ps Typical Propagation Delay
- 35 ps Typical Rise and Fall Times
- Positive CML Output with Operating Range:
 $V_{CC} = 2.375$ V to 3.465 V with $V_{EE} = 0$ V
- Negative CML Output with RSNECL or NECL Inputs with
Operating Range: $V_{CC} = 0$ V with $V_{EE} = -2.375$ V to -3.465 V
- CML Output Level; 400 mV Peak-to-Peak Output with
50 Ω Receiver Resistor to V_{CC}
- 50 Ω Internal Input and Output Termination Resistors
- Compatible with Existing 2.5 V/3.3 V LVEP, EP, LVEL
and SG Devices
- V_{BB} Reference Voltage Output
- Pb-Free Packages are Available



ON Semiconductor®

<http://onsemi.com>

MARKING DIAGRAM*



QFN-16
MN SUFFIX
CASE 485G

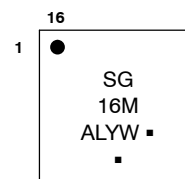

A = Assembly Location
L = Wafer Lot
Y = Year
W = Work Week
▪ = Pb-Free Package

(Note: Microdot may be in either location)

*For additional marking information, refer to Application Note AND8002/D.

ORDERING INFORMATION

See detailed ordering and shipping information in the package dimensions section on page 10 of this data sheet.

NBSG16M

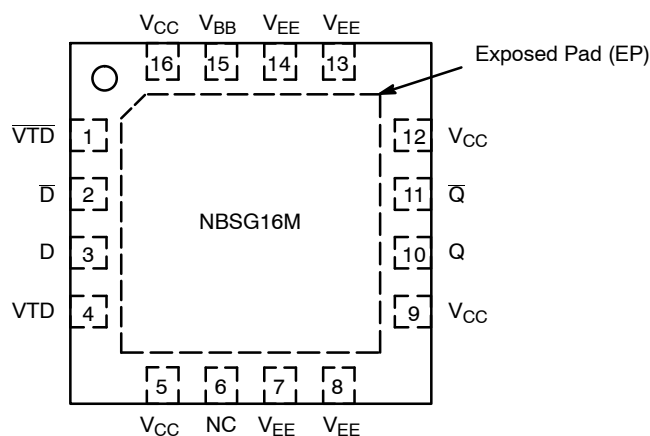

Figure 1. QFN-16 Pinout (Top View)

Table 1. PIN DESCRIPTION

Pin	Name	I/O	Description
1	$\overline{V_{TD}}$	-	Internal 50 Ω Termination Pin. See Table 2. (Note 3)
2	\overline{D}	LVDS, CML, ECL, LVTTTL, LVCMOS Input	Inverted Differential Input (Note 3)
3	D	LVDS, CML, ECL, LVTTTL, LVCMOS Input	Noninverted Differential Input. (Note 3)
4	V_{TD}	-	Internal 50 Ω Termination Pin. See Table 2. (Note 3)
5	V_{CC}	-	Positive Supply Voltage. All V_{CC} pins must be externally connected to Power Supply to guarantee proper operation.
6	NC	-	No Connect (Note 1)
7	V_{EE}	-	Negative Supply Voltage. All V_{EE} pins must be externally connected to Power Supply to guarantee proper operation.
8	V_{EE}	-	Negative Supply Voltage. All V_{EE} pins must be externally connected to Power Supply to guarantee proper operation.
9	V_{CC}	-	Positive Supply Voltage. All V_{CC} pins must be externally connected to Power Supply to guarantee proper operation.
10	Q	CML Output	Noninverted CML Differential Output with Internal 50 Ω Source Termination Resistor. (Note 2)
11	\overline{Q}	CML Output	Inverted CML Differential Output with Internal 50 Ω Source Termination Resistor. (Note 2)
12	V_{CC}	-	Positive Supply Voltage. All V_{CC} pins must be externally connected to Power Supply to guarantee proper operation.
13	V_{EE}	-	Negative Supply Voltage. All V_{EE} pins must be externally connected to Power Supply to guarantee proper operation.
14	V_{EE}	-	Negative Supply Voltage. All V_{EE} pins must be externally connected to Power Supply to guarantee proper operation.
15	V_{BB}	-	Internally Generated ECL Reference Output Voltage
16	V_{CC}	-	Positive Supply Voltage. All V_{CC} pins must be externally connected to Power Supply to guarantee proper operation.
-	EP	-	The Exposed Pad (EP) and the QFN-16 package bottom is thermally connected to the die for improved heat transfer out of package. The exposed pad must be attached to a heat-sinking conduit. The pad is not electrically connected to the die but may be electrically and thermally connected to V_{EE} on the PC board.

1. The NC pins are electrically connected to the die and MUST be left open.
2. CML outputs require 50 Ω receiver termination resistor to V_{CC} for proper operation.
3. In the differential configuration when the input termination pin (V_{TD} , $\overline{V_{TD}}$) are connected to a common termination voltage, and if no signal is applied then the device will be susceptible to self-oscillation.

NBSG16M

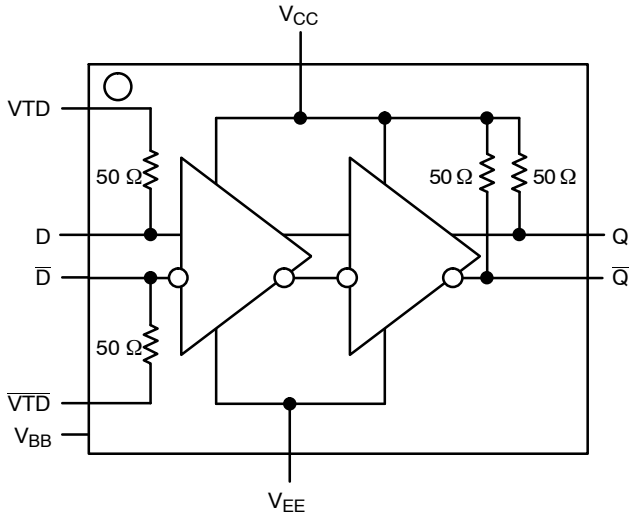

Figure 2. Logic Diagram

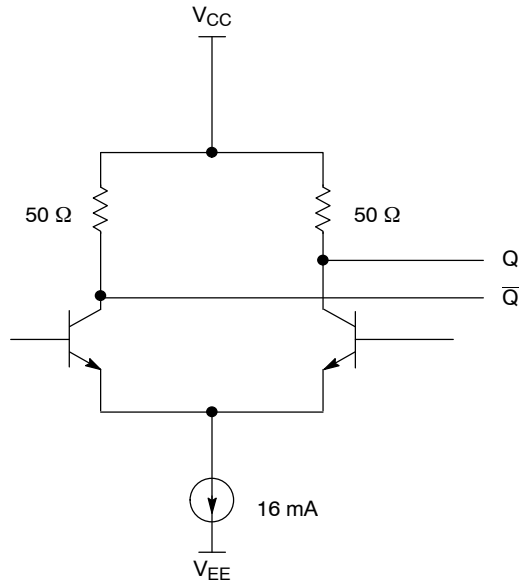

Figure 3. CML Output Structure

Table 2. Interfacing Options

INTERFACING OPTIONS	CONNECTIONS
CML	Connect VTD and \overline{VTD} to V_{CC}
LVDS	Connect VTD and \overline{VTD} together
AC-COUPLED	Bias VTD and \overline{VTD} Inputs within (V_{IHCMR}) Common Mode Range
RSECL, PECL, NECL	Standard ECL Termination Techniques
LVTTTL, LVCMOS	An external voltage should be applied to the unused complementary differential input. Nominal voltage 1.5 V for LVTTTL and $V_{CC}/2$ for LVCMOS inputs.

Table 3. ATTRIBUTES

Characteristics	Value	
ESD Protection	Human Body Model	> 1 kV
	Machine Model	> 100 V
	Charged Device Model	> 4 kV
Moisture Sensitivity, Indefinite Time Out of Drypack (Note 4)	Pb Pkg	Pb-Free Pkg
	QFN-16	Level 1
Flammability Rating	Oxygen Index: 28 to 34	UL 94 V-0 @ 0.125 in
Transistor Count	145	
Meets or exceeds JEDEC Spec EIA/JESD78 IC Latchup Test		

4. For additional Moisture Sensitivity information, refer to Application Note AND8003/D.

NBSG16M

Table 4. MAXIMUM RATINGS

Symbol	Parameter	Condition 1	Condition 2	Rating	Unit
V_{CC}	Positive Power Supply	$V_{EE} = 0\text{ V}$		3.6	V
V_{EE}	Negative Power Supply	$V_{CC} = 0\text{ V}$		-3.6	V
V_I	Positive Input Negative Input	$V_{EE} = 0\text{ V}$ $V_{CC} = 0\text{ V}$	$V_I \leq V_{CC}$ $V_I \geq V_{EE}$	3.6 -3.6	V V
V_{INPP}	Differential Input Voltage $ D - \bar{D} $	$V_{CC} - V_{EE} \geq 2.8\text{ V}$ $V_{CC} - V_{EE} < 2.8\text{ V}$		2.8 $ V_{CC} - V_{EE} $	V
I_{IN}	Input Current Through R_T (50 Ω Resistor)	Static Surge		45 80	mA mA
I_{out}	Output Current	Continuous Surge		25 50	mA mA
I_{BB}	V_{BB} Sink/Source			1.0	mA
T_A	Operating Temperature Range			-40 to +85	$^{\circ}\text{C}$
T_{stg}	Storage Temperature Range			-65 to +150	$^{\circ}\text{C}$
θ_{JA}	Thermal Resistance (Junction-to-Ambient) (Note 5)	0 lfpm 500 lfpm	QFN-16 QFN-16	42 35	$^{\circ}\text{C}/\text{W}$ $^{\circ}\text{C}/\text{W}$
θ_{JC}	Thermal Resistance (Junction-to-Case)	1S2P (Note 5)	QFN-16	4.0	$^{\circ}\text{C}/\text{W}$
T_{sol}	Wave Solder Pb Pb-Free	<2 to 3 sec @ 248 $^{\circ}\text{C}$ <2 to 3 sec @ 260 $^{\circ}\text{C}$		265 265	$^{\circ}\text{C}$

Stresses exceeding Maximum Ratings may damage the device. Maximum Ratings are stress ratings only. Functional operation above the Recommended Operating Conditions is not implied. Extended exposure to stresses above the Recommended Operating Conditions may affect device reliability.

5. JEDEC standard multilayer board – 1S2P (1 signal, 2 power)

NBSG16M

Table 5. DC CHARACTERISTICS, POSITIVE CML OUTPUT $V_{CC} = 2.5\text{ V}$; $V_{EE} = 0\text{ V}$ (Note 6)

Symbol	Characteristic	-40°C			25°C			85°C			Unit
		Min	Typ	Max	Min	Typ	Max	Min	Typ	Max	
I_{CC}	Positive Power Supply Current	37	43	51	37	43	51	37	43	51	mA
V_{OH}	Output HIGH Voltage (Note 7)	$V_{CC} - 40$	$V_{CC} - 10$	V_{CC}	$V_{CC} - 40$	$V_{CC} - 10$	V_{CC}	$V_{CC} - 40$	$V_{CC} - 10$	V_{CC}	mV
V_{OL}	Output LOW Voltage (Note 6)		$V_{CC} - 400$	$V_{CC} - 330$		$V_{CC} - 400$	$V_{CC} - 330$		$V_{CC} - 400$	$V_{CC} - 330$	mV
V_{IH}	Input HIGH Voltage (Single-Ended) (Note 8)	$V_{EE} + 1.275$	$V_{CC} - 1.0^*$	V_{CC}	$V_{EE} + 1.275$	$V_{CC} - 1.0^*$	V_{CC}	$V_{EE} + 1.275$	$V_{CC} - 1.0^*$	V_{CC}	V
V_{IL}	Input LOW Voltage (Single-Ended) (Note 8)	V_{EE}	$V_{CC} - 1.4^*$	$V_{IH} - 0.150$	V_{EE}	$V_{CC} - 1.4^*$	$V_{IH} - 0.150$	V_{EE}	$V_{CC} - 1.4^*$	$V_{IH} - 0.150$	V
V_{BB}	ECL Reference Voltage Output	1075	1170	1265	1075	1170	1265	1075	1170	1265	mV
V_{IHCMR}	Input HIGH Voltage Common Mode Range (Note 8) (Differential Configuration)	1.2		2.5	1.2		2.5	1.2		2.5	V
R_{TIN}	Internal Input Termination Resistor	45	50	55	45	50	55	45	50	55	Ω
R_{TOUT}	Internal Output Termination Resistor	45	50	55	45	50	55	45	50	55	Ω
I_{IH}	Input HIGH Current (@ V_{IH})		60	100		60	100		60	100	μA
I_{IL}	Input LOW Current (@ V_{IL})		25	50		25	50		25	50	μA

NOTE: Device will meet the specifications after thermal equilibrium has been established when mounted in a test socket or printed circuit board with maintained transverse airflow greater than 500 lfm. Electrical parameters are guaranteed only over the declared operating temperature range. Functional operation of the device exceeding these conditions is not implied. Device specification limit values are applied individually under normal operating conditions and not valid simultaneously.

6. Input and output parameters vary 1:1 with V_{CC} . V_{EE} can vary +0.125 V to -0.965 V.

7. All loading with 50 Ω to V_{CC} .

8. V_{IHCMR} min varies 1:1 with V_{EE} , V_{IHCMR} max varies 1:1 with V_{CC} . The V_{IHCMR} range is referenced to the most positive side of the differential input signal.

*Typicals used for testing purposes.

NBSG16M

Table 6. DC CHARACTERISTICS, POSITIVE CML OUTPUT $V_{CC} = 3.3\text{ V}$; $V_{EE} = 0\text{ V}$ (Note 9)

Symbol	Characteristic	-40°C			25°C			85°C			Unit
		Min	Typ	Max	Min	Typ	Max	Min	Typ	Max	
I_{CC}	Positive Power Supply Current	37	43	51	37	43	51	37	43	51	mA
V_{OH}	Output HIGH Voltage (Note 10)	$V_{CC} - 40$	$V_{CC} - 10$	V_{CC}	$V_{CC} - 40$	$V_{CC} - 10$	V_{CC}	$V_{CC} - 40$	$V_{CC} - 10$	V_{CC}	mV
V_{OL}	Output LOW Voltage (Note 9)		$V_{CC} - 400$	$V_{CC} - 330$		$V_{CC} - 400$	$V_{CC} - 330$		$V_{CC} - 400$	$V_{CC} - 330$	mV
V_{IH}	Input HIGH Voltage (Single-Ended) (Note 11)	$V_{EE} + 1.275$	$V_{CC} - 1.0^*$	V_{CC}	$V_{EE} + 1.275$	$V_{CC} - 1.0^*$	V_{CC}	$V_{EE} + 1.275$	$V_{CC} - 1.0^*$	V_{CC}	V
V_{IL}	Input LOW Voltage (Single-Ended) (Note 11)	V_{EE}	$V_{CC} - 1.4^*$	$V_{IH} - 0.150$	V_{EE}	$V_{CC} - 1.4^*$	$V_{IH} - 0.150$	V_{EE}	$V_{CC} - 1.4^*$	$V_{IH} - 0.150$	V
V_{BB}	ECL Reference Voltage Output	1875	1970	2065	1875	1970	2065	1875	1970	2065	mV
V_{IHCMR}	Input HIGH Voltage Common Mode Range (Note 11) (Differential Configuration)	1.2		3.3	1.2		3.3	1.2		3.3	V
R_{TIN}	Internal Input Termination Resistor	45	50	55	45	50	55	45	50	55	Ω
R_{TOUT}	Internal Output Termination Resistor	45	50	55	45	50	55	45	50	55	Ω
I_{IH}	Input HIGH Current (@ V_{IH})		60	100		60	100		60	100	μA
I_{IL}	Input LOW Current (@ V_{IL})		25	50		25	50		25	50	μA

NOTE: Device will meet the specifications after thermal equilibrium has been established when mounted in a test socket or printed circuit board with maintained transverse airflow greater than 500 lpm. Electrical parameters are guaranteed only over the declared operating temperature range. Functional operation of the device exceeding these conditions is not implied. Device specification limit values are applied individually under normal operating conditions and not valid simultaneously.

9. Input and output parameters vary 1:1 with V_{CC} . V_{EE} can vary +0.925 V to -0.165 V.

10. All loading with 50 Ω to V_{CC} .

11. V_{IHCMR} min varies 1:1 with V_{EE} , V_{IHCMR} max varies 1:1 with V_{CC} . The V_{IHCMR} range is referenced to the most positive side of the differential input signal.

*Typicals used for testing purposes.

NBSG16M

Table 7. DC CHARACTERISTICS, NEGATIVE CML OUTPUT $V_{CC} = 0\text{ V}$; $V_{EE} = -3.465\text{ to }-2.375\text{ V}$ (Note 12)

Symbol	Characteristic	-40°C			25°C			85°C			Unit
		Min	Typ	Max	Min	Typ	Max	Min	Typ	Max	
I_{CC}	Positive Power Supply Current	37	43	51	37	43	51	37	43	51	mA
V_{OH}	Output HIGH Voltage (Note 13)	$V_{CC} - 40$	$V_{CC} - 10$	V_{CC}	$V_{CC} - 40$	$V_{CC} - 10$	V_{CC}	$V_{CC} - 40$	$V_{CC} - 10$	V_{CC}	mV
V_{OL}	Output LOW Voltage (Note 12)		$V_{CC} - 400$	$V_{CC} - 330$		$V_{CC} - 400$	$V_{CC} - 330$		$V_{CC} - 400$	$V_{CC} - 330$	mV
V_{IH}	Input HIGH Voltage (Single-Ended) (Note 13)	$V_{EE} + 1.275$	$V_{CC} - 1.0^*$	V_{CC}	$V_{EE} + 1.275$	$V_{CC} - 1.0^*$	V_{CC}	$V_{EE} + 1.275$	$V_{CC} - 1.0^*$	V_{CC}	V
V_{IL}	Input LOW Voltage (Single-Ended) (Note 13)	V_{EE}	$V_{CC} - 1.4^*$	$V_{IH}^- - 0.150$	V_{EE}	$V_{CC} - 1.4^*$	$V_{IH}^- - 0.150$	V_{EE}	$V_{CC} - 1.4^*$	$V_{IH}^- - 0.150$	V
V_{BB}	ECL Reference Voltage Output	-1425	-1330	-1235	-1425	-1330	-1235	-1425	-1330	-1235	mV
V_{IHCMR}	Input HIGH Voltage Common Mode Range (Note 14) (Differential Configuration)	$V_{EE} + 1.2$		V_{CC}	$V_{EE} + 1.2$		V_{CC}	$V_{EE} + 1.2$		V_{CC}	V
R_{TIN}	Internal Input Termination Resistor	45	50	55	45	50	55	45	50	55	Ω
R_{TOUT}	Internal Output Termination Resistor	45	50	55	45	50	55	45	50	55	Ω
I_{IH}	Input HIGH Current (@ V_{IH})		60	100		60	100		60	100	μA
I_{IL}	Input LOW Current (@ V_{IL})		25	50		25	50		25	50	μA

NOTE: Device will meet the specifications after thermal equilibrium has been established when mounted in a test socket or printed circuit board with maintained transverse airflow greater than 500 lfm. Electrical parameters are guaranteed only over the declared operating temperature range. Functional operation of the device exceeding these conditions is not implied. Device specification limit values are applied individually under normal operating conditions and not valid simultaneously.

12. Input and output parameters vary 1:1 with V_{CC} .

13. All loading with $50\ \Omega$ to V_{CC} .

14. V_{IHCMR} min varies 1:1 with V_{EE} , V_{IHCMR} max varies 1:1 with V_{CC} . The V_{IHCMR} range is referenced to the most positive side of the differential input signal.

*Typicals used for testing purposes.

NBSG16M

Table 8. AC CHARACTERISTICS $V_{CC} = 0\text{ V}$; $V_{EE} = -3.465\text{ V}$ to -2.375 V or $V_{CC} = 2.375\text{ V}$ to 3.465 V ; $V_{EE} = 0\text{ V}$

Symbol	Characteristic	-40°C			25°C			85°C			Unit
		Min	Typ	Max	Min	Typ	Max	Min	Typ	Max	
V_{OUTPP}	Output Voltage Amplitude (See Figure 4) (Note 15) $f_{in} < 7\text{ GHz}$ $f_{in} < 10\text{ GHz}$	300 200	400 250		300 200	400 250		300 100	400 150		mV
t_{PLH} , t_{PHL}	Propagation Delay to Output Differential	90	110	150	100	120	150	100	125	155	ps
t_{SKEW}	Duty Cycle Skew (Note 16)		3	15		3	15		3	15	ps
t_{JITTER}	RMS Random Clock Jitter (Note 18) Peak-to-Peak Data Dependent Jitter (Note 19) $f_{in} < 10\text{ GHz}$ $f_{in} < 10\text{ Gb/s}$		0.2 8	1 15		0.2 8	1 15		0.2 8	1.0 15	ps
V_{INPP}	Input Voltage Swing/Sensitivity (Differential Configuration) (Note 17)	75		2500	75		2500	75		2500	mV
t_r t_f	Output Rise/Fall Times @ 1 GHz (20% – 80%) Q, \bar{Q}	21	35	53	21	35	53	21	35	53	ps

NOTE: Device will meet the specifications after thermal equilibrium has been established when mounted in a test socket or printed circuit board with maintained transverse airflow greater than 500 lfm. Electrical parameters are guaranteed only over the declared operating temperature range. Functional operation of the device exceeding these conditions is not implied. Device specification limit values are applied individually under normal operating conditions and not valid simultaneously.

15. Measured using a 400 mV source, 50% duty cycle clock source. All loading with $50\ \Omega$ to V_{CC} . Input edge rates 40 ps (20% – 80%).

16. See Figure 8 $t_{skew} = |t_{PLH} - t_{PHL}|$ for a nominal 50% differential clock input waveform.

17. $V_{INPP(max)}$ cannot exceed $V_{CC} - V_{EE}$. (Applicable only when $V_{CC} - V_{EE} < 2500\text{ mV}$). Input voltage swing is a single-ended measurement operating in differential mode.

18. Additive RMS jitter with 50% duty cycle clock signal at 10GHz.

19. Additive Peak-to-Peak data dependent jitter with NRZ PRBS $2^{31}-1$ data rate at 10 Gb/s.

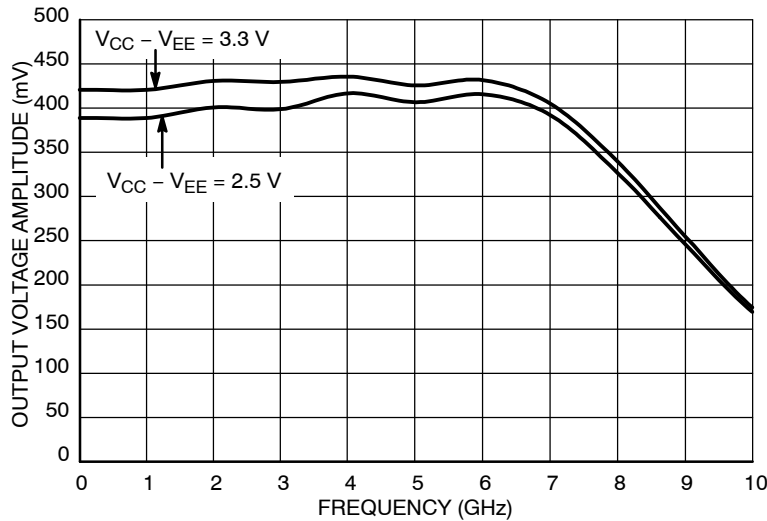

Figure 4. Output Voltage Amplitude (V_{OUTPP}) versus Input Clock Frequency (f_{in}) at Ambient Temperature (Typical)

NBSG16M

Application Information

All inputs can accept PECL, CML, and LVDS signal levels. The input voltage can range from V_{CC} to 1.2 V.

Examples interfaces are illustrated below in a 50 Ω environment ($Z = 50 \Omega$).

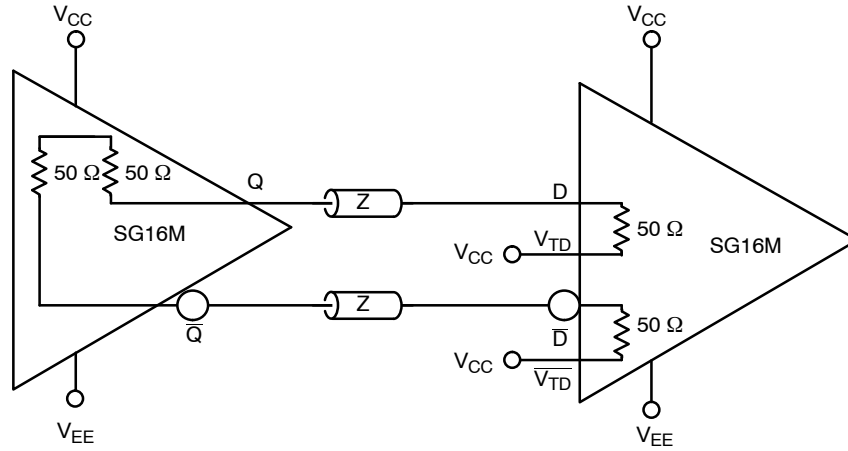

Figure 5. CML to CML Interface

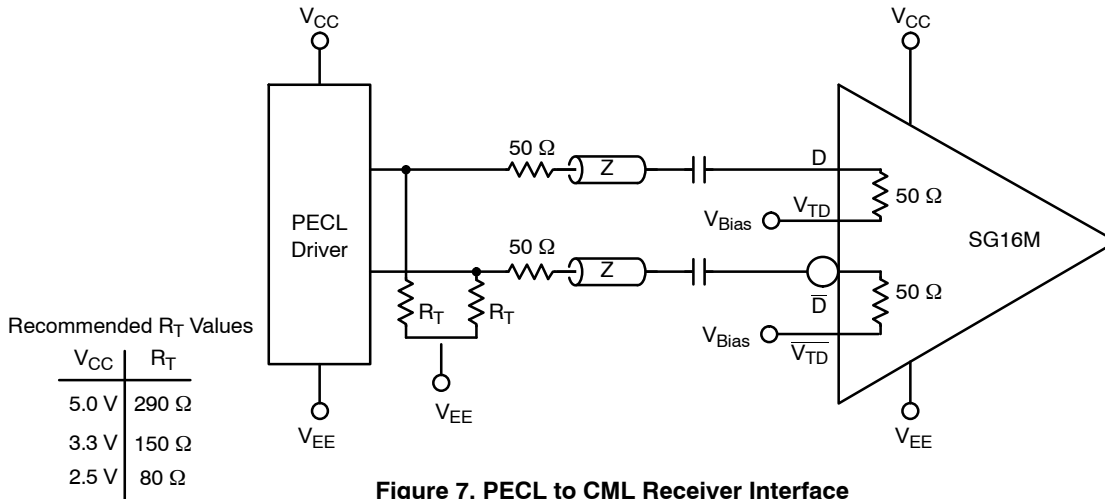

Figure 7. PECL to CML Receiver Interface

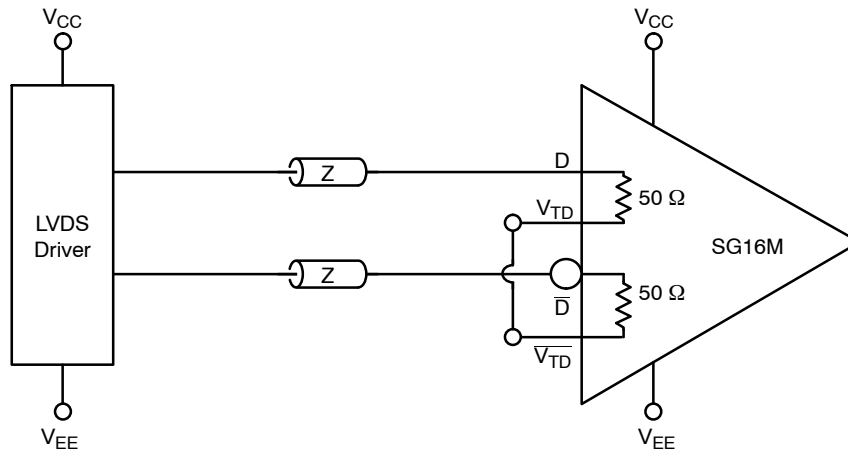

Figure 6. LVDS to CML Receiver Interface

NBSG16M

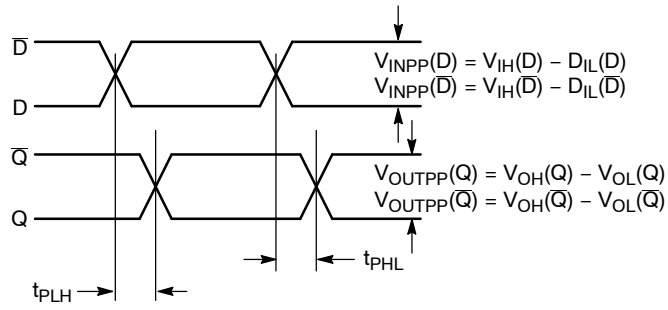
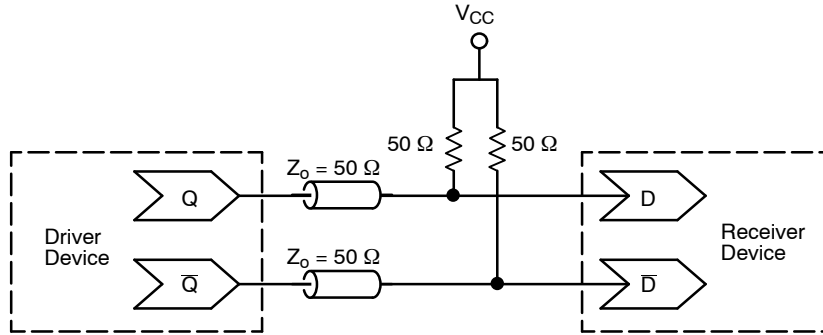

Figure 8. AC Reference Measurement



**Figure 9. Typical Termination for Output Driver and Device Evaluation
(Refer to Application Note AND8020 – Termination of ECL Logic Devices)**

ORDERING INFORMATION

Device	Package	Shipping†
NBSG16MMN	QFN-16	123 Units / Rail
NBSG16MMNG	QFN-16 (Pb-Free)	123 Units / Rail
NBSG16MMNR2	QFN-16	3000 / Tape & Reel
NBSG16MMNR2G	QFN-16 (Pb-Free)	3000 / Tape & Reel

†For information on tape and reel specifications, including part orientation and tape sizes, please refer to our Tape and Reel Packaging Specifications Brochure, BRD8011/D.

NBSG16M

PACKAGE DIMENSIONS

16 PIN QFN
CASE 485G-01
ISSUE C

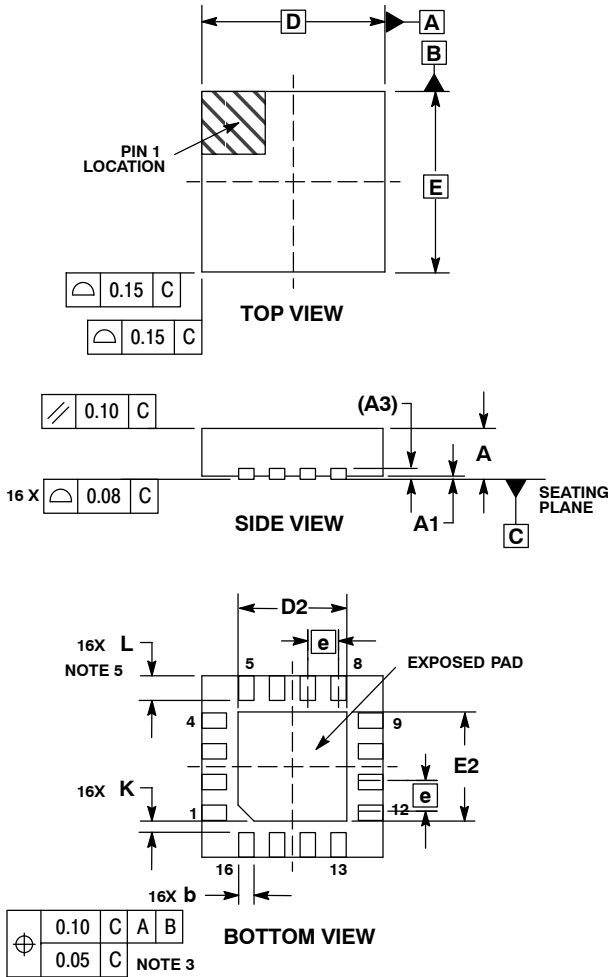

- NOTES:
1. DIMENSIONING AND TOLERANCING PER ASME Y14.5M, 1994.
 2. CONTROLLING DIMENSION: MILLIMETERS.
 3. DIMENSION b APPLIES TO PLATED TERMINAL AND IS MEASURED BETWEEN 0.25 AND 0.30 MM FROM TERMINAL.
 4. COPLANARITY APPLIES TO THE EXPOSED PAD AS WELL AS THE TERMINALS.
 5. L_{max} CONDITION CAN NOT VIOLATE 0.2 MM MINIMUM SPACING BETWEEN LEAD TIP AND FLAG

MILLIMETERS		
DIM	MIN	MAX
A	0.80	1.00
A1	0.00	0.05
A3	0.20 REF	
b	0.18	0.30
D	3.00 BSC	
D2	1.65	1.85
E	3.00 BSC	
E2	1.65	1.85
e	0.50 BSC	
K	0.18 TYP	
L	0.30	0.50

SOLDERING FOOTPRINT*

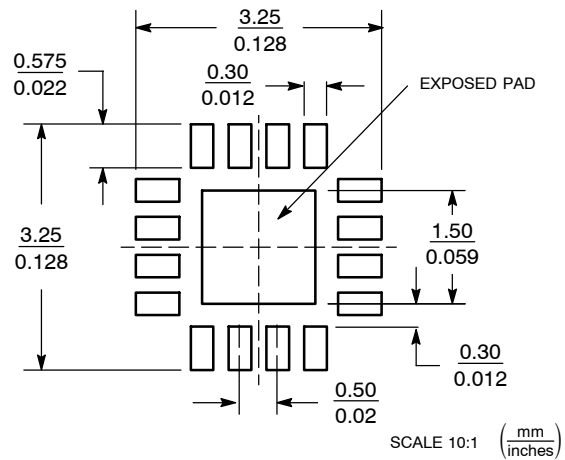

*For additional information on our Pb-Free strategy and soldering details, please download the ON Semiconductor Soldering and Mounting Techniques Reference Manual, SOLDERRM/D.

ON Semiconductor and are registered trademarks of Semiconductor Components Industries, LLC (SCILLC). SCILLC reserves the right to make changes without further notice to any products herein. SCILLC makes no warranty, representation or guarantee regarding the suitability of its products for any particular purpose, nor does SCILLC assume any liability arising out of the application or use of any product or circuit, and specifically disclaims any and all liability, including without limitation special, consequential or incidental damages. "Typical" parameters which may be provided in SCILLC data sheets and/or specifications can and do vary in different applications and actual performance may vary over time. All operating parameters, including "Typicals" must be validated for each customer application by customer's technical experts. SCILLC does not convey any license under its patent rights nor the rights of others. SCILLC products are not designed, intended, or authorized for use as components in systems intended for surgical implant into the body, or other applications intended to support or sustain life, or for any other application in which the failure of the SCILLC product could create a situation where personal injury or death may occur. Should Buyer purchase or use SCILLC products for any such unintended or unauthorized application, Buyer shall indemnify and hold SCILLC and its officers, employees, subsidiaries, affiliates, and distributors harmless against all claims, costs, damages, and expenses, and reasonable attorney fees arising out of, directly or indirectly, any claim of personal injury or death associated with such unintended or unauthorized use, even if such claim alleges that SCILLC was negligent regarding the design or manufacture of the part. SCILLC is an Equal Opportunity/Affirmative Action Employer. This literature is subject to all applicable copyright laws and is not for resale in any manner.

PUBLICATION ORDERING INFORMATION

LITERATURE FULFILLMENT:
Literature Distribution Center for ON Semiconductor
P.O. Box 5163, Denver, Colorado 80217 USA
Phone: 303-675-2175 or 800-344-3860 Toll Free USA/Canada
Fax: 303-675-2176 or 800-344-3867 Toll Free USA/Canada
Email: orderlit@onsemi.com

N. American Technical Support: 800-282-9855 Toll Free
USA/Canada
Europe, Middle East and Africa Technical Support:
Phone: 421 33 790 2910
Japan Customer Focus Center
Phone: 81-3-5773-3850

ON Semiconductor Website: www.onsemi.com
Order Literature: <http://www.onsemi.com/orderlit>

For additional information, please contact your local Sales Representative

Компания «Океан Электроники» предлагает заключение долгосрочных отношений при поставках импортных электронных компонентов на взаимовыгодных условиях!

Наши преимущества:

- Поставка оригинальных импортных электронных компонентов напрямую с производств Америки, Европы и Азии, а так же с крупнейших складов мира;
- Широкая линейка поставок активных и пассивных импортных электронных компонентов (более 30 млн. наименований);
- Поставка сложных, дефицитных, либо снятых с производства позиций;
- Оперативные сроки поставки под заказ (от 5 рабочих дней);
- Экспресс доставка в любую точку России;
- Помощь Конструкторского Отдела и консультации квалифицированных инженеров;
- Техническая поддержка проекта, помощь в подборе аналогов, поставка прототипов;
- Поставка электронных компонентов под контролем ВП;
- Система менеджмента качества сертифицирована по Международному стандарту ISO 9001;
- При необходимости вся продукция военного и аэрокосмического назначения проходит испытания и сертификацию в лаборатории (по согласованию с заказчиком);
- Поставка специализированных компонентов военного и аэрокосмического уровня качества (Xilinx, Altera, Analog Devices, Intersil, Interpoint, Microsemi, Actel, Aeroflex, Peregrine, VPT, Syfer, Eurofarad, Texas Instruments, MS Kennedy, Miteq, Cobham, E2V, MA-COM, Hittite, Mini-Circuits, General Dynamics и др.);

Компания «Океан Электроники» является официальным дистрибьютором и эксклюзивным представителем в России одного из крупнейших производителей разъемов военного и аэрокосмического назначения «JONHON», а так же официальным дистрибьютором и эксклюзивным представителем в России производителя высокотехнологичных и надежных решений для передачи СВЧ сигналов «FORSTAR».



JONHON

«JONHON» (основан в 1970 г.)

Разъемы специального, военного и аэрокосмического назначения:

(Применяются в военной, авиационной, аэрокосмической, морской, железнодорожной, горно- и нефтедобывающей отраслях промышленности)

«FORSTAR» (основан в 1998 г.)

ВЧ соединители, коаксиальные кабели,
кабельные сборки и микроволновые компоненты:

(Применяются в телекоммуникациях гражданского и специального назначения, в средствах связи, РЛС, а так же военной, авиационной и аэрокосмической отраслях промышленности).



Телефон: 8 (812) 309-75-97 (многоканальный)

Факс: 8 (812) 320-03-32

Электронная почта: ocean@oceanchips.ru

Web: <http://oceanchips.ru/>

Адрес: 198099, г. Санкт-Петербург, ул. Калинина, д. 2, корп. 4, лит. А