



## PROGRAMMABLE OVERVOLTAGE PROTECTOR QUAD FORWARD-CONDUCTING P-GATE THYRISTOR

### TISP61089QB SLIC Overvoltage Protector

#### Quad Voltage-Programmable Protector

- Wide -20 V to -155 V Programming Range
- Low 5 mA max. Gate Triggering Current
- High 150 mA min. Holding Current
- Rated for ITU-T and YD/T-950 10/700 impulses
- Rated for Telcordia Intra-building impulses

#### 10/700 Protection Voltage Specified

Element	Protection Level 40 A, 5/310
Diode	+12
Crowbar $V_{GG} = -48 V$	-64

#### Description

Bourns® TISP61089QB is a quad forward-conducting buffered p-gate overvoltage protector. It is designed to protect monolithic SLICs (Subscriber Line Interface Circuits) against overvoltages on the telephone line caused by lightning, a.c. power contact and induction. The TISP61089QB limits voltages that exceed the SLIC supply rail voltage. The TISP61089QB parameters are specified to allow equipment compliance with Telcordia GR-1089-CORE Intra-building, ITU-T K.20, K.21 and K.45 and YD/T-950.

The SLIC line driver section is typically powered from 0 V (ground) and a negative voltage in the region of -20 V to -155 V. The protector gate is connected to this negative supply. This references the protection (clipping) voltage to the negative supply voltage. As the protection voltage will then track the negative supply voltage the overvoltage stress on the SLIC is minimized.

Positive overvoltages are clipped to ground by diode forward conduction. Negative overvoltages are initially clipped close to the SLIC negative supply rail value. If sufficient current is available from the overvoltage, then the protector will crowbar into a low voltage on-state condition. As the overvoltage subsides, the high holding current of the crowbar helps prevent d.c. latchup.

These monolithic protection devices are fabricated in ion-implanted planar vertical power structures for high reliability and are virtually transparent in normal operation. The TISP61089QB buffered gate design reduces the loading on the SLIC supply during overvoltages caused by power cross and induction. The TISP61089QB is available in an 8-pin plastic small-outline surface mount package.

#### How to Order

Device	Package	Carrier	Order As	Marking Code	Standard Quantity
TISP61089QB	8 Pin Small Outline (D008)	Embossed Tape Reeled	TISP61089QBDR-S	1089QB	2500

#### D Package (Top View)

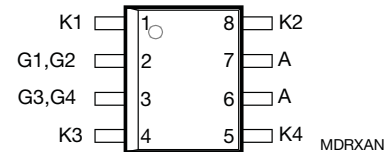

#### Device Symbol

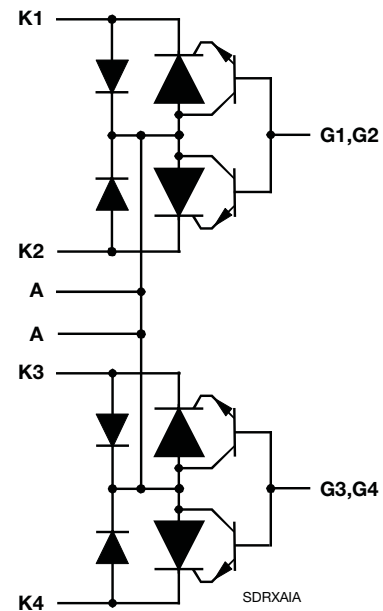

\*RoHS Directive 2002/95/EC Jan. 27, 2003 including annex and RoHS Recast 2011/65/EU June 8, 2011.

JULY 2010 - REVISED MAY 2012

Specifications are subject to change without notice.

Customers should verify actual device performance in their specific applications.

# TISP61089QB SLIC Overvoltage Protector

**BOURNS®**

## Absolute Maximum Ratings, $T_J = 25\text{ °C}$ (Unless Otherwise Noted)

Rating	Symbol	Value	Unit
Repetitive peak off-state voltage, $I_G = 0$	$V_{DRM}$	-170	V
Repetitive peak gate-cathode voltage, $V_{KA} = 0$	$V_{GKRM}$	-167	V
Non-repetitive peak on-state pulse current (see Notes 1 and 2) 10/1000 $\mu\text{s}$ (Bellcore GR-1089-CORE, Issue 1, November 1994, Section 4) 5/310 $\mu\text{s}$ (ITU-T K.20/21/45, YD/T-950, open circuit voltage waveshape 10/700) 2/40 $\mu\text{s}$ (IEC61000-4-5, 1.2/50 $\mu\text{s}$ open circuit voltage, 2 ohm + 10 ohm, see Note 4) 2/10 $\mu\text{s}$ (Bellcore GR-1089-CORE, Issue 1, November 1994, Section 4)	$I_{TSP}$	30 40 85 120	A
Non-repetitive peak on-state current, 60 Hz (see Notes 1, 2 and 3) 900 s	$I_{TSM}$	0.5	A
Non-repetitive peak gate current, 2/10 $\mu\text{s}$ pulse, cathodes commoned (see Notes 1 and 2)	$I_{GSM}$	40	A
Junction temperature	$T_J$	-40 to +150	$^{\circ}\text{C}$
Storage temperature range	$T_{stg}$	-40 to +150	$^{\circ}\text{C}$

- NOTES: 1. Initially the protector must be in thermal equilibrium with  $T_J = 25\text{ °C}$ . The surge may be repeated after the device returns to its initial conditions.
2. These non-repetitive rated currents are peak values for either polarity. The rated current values may be applied to any cathode-anode terminal pair. Additionally, all cathode-anode terminal pairs may have their rated current values applied simultaneously (in this case the anode terminal current will be four times the rated current value of an individual terminal pair).
3. EIA/JESD51-2 environment and EIA/JESD51-7 high effective thermal conductivity test board (multi-layer) connected with 0.6 mm printed wiring track widths.
4. Combination wave generator as specified in ITU-T K.20, K.21, K.44.

## Recommended Operating Conditions

	Min	Typ	Max	Unit
$C_G$ Gate decoupling capacitor		100		nF

## Electrical Characteristics, $T_J = 25\text{ °C}$ (Unless Otherwise Noted)

Parameter	Test Conditions	Min	Typ	Max	Unit
$I_D$ Off-state current	$V_D = V_{DRM}, V_{GK} = 0$			-5	$\mu\text{A}$
$V_{(BO)}$ Breakover voltage	10/700 $\mu\text{s}$ , $I_T = -40\text{ A}$ , $R_S = 55\ \Omega$ , $V_{GG} = -48\text{ V}$ , $C_G = 100\text{ nF}$			-64	V
$V_F$ Forward voltage	$I_F = 5\text{ A}$ , $t_w = 200\ \mu\text{s}$			3	V
$V_{FRM}$ Peak forward recovery voltage	10/700 $\mu\text{s}$ , $I_F = 40\text{ A}$ , $R_S = 55\ \Omega$ , $V_{GG} = -48\text{ V}$ , $C_G = 100\text{ nF}$		12		V
$I_H$ Holding current	$I_T = -1\text{ A}$ , $di/dt = 1\text{ A/ms}$ , $V_{GG} = -100\text{ V}$	-150			mA
$I_{GAS}$ Gate reverse current	$V_{GG} = V_{GK} = V_{GKRM}, V_{KA} = 0$			-5	$\mu\text{A}$
$I_{GT}$ Gate trigger current	$I_T = 3\text{ A}$ , $t_{p(g)} \geq 20\ \mu\text{s}$ , $V_{GG} = -100\text{ V}$			5	mA
$V_{GT}$ Gate trigger voltage	$I_T = 3\text{ A}$ , $t_{p(g)} \geq 20\ \mu\text{s}$ , $V_{GG} = -100\text{ V}$			2.5	V
$C_{AK}$ Anode-cathode off-state capacitance	$f = 1\text{ MHz}$ , $V_d = 1\text{ V}$ , $I_G = 0$ , (see Note 5)	$V_D = -3\text{ V}$		100	pF
		$V_D = -48\text{ V}$		50	

- NOTE: 5. These capacitance measurements employ a three terminal capacitance bridge incorporating a guard circuit. The unmeasured device terminals are a.c. connected to the guard terminal of the bridge.

# TISP61089QB SLIC Overvoltage Protector

**BOURNS®**

## Thermal Characteristics

Parameter	Test Conditions	Min	Typ	Max	Unit
$R_{\theta JA}$	Junction to free air thermal resistance			160	°C/W

*Test Conditions:  $P_{tot} = 0.8\text{ W}$ ,  $T_A = 25\text{ °C}$ ,  $5\text{ cm}^2$ , FR4 PCB*

## Parameter Measurement Information

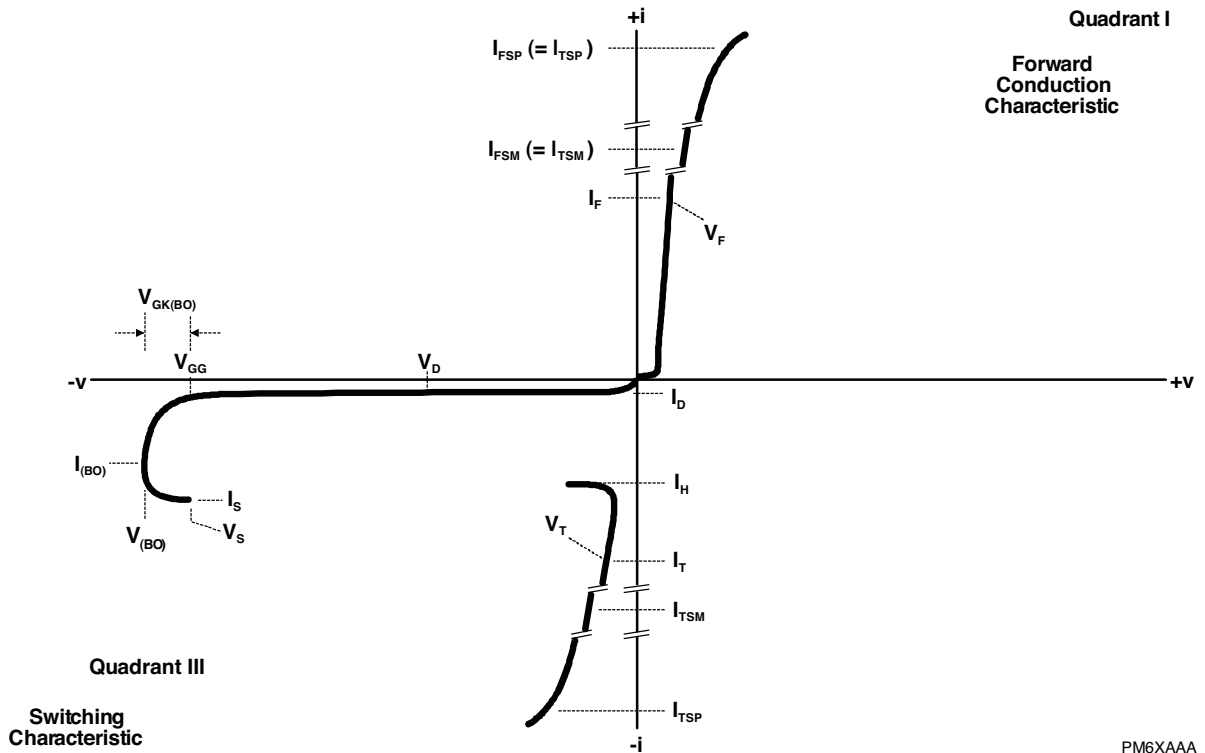

Figure 1. Voltage-Current Characteristic

PM6XAAA

# TISP61089QB SLIC Overvoltage Protector

**BOURNS®**

## Applications Information

### Typical Applications Circuit

Figure 2 shows a typical TISP61089QB SLIC card protection circuit. The incoming line conductors, RING1/RING2 and TIP1/TIP2, connect to the relay matrix via the series overcurrent protection. Positive temperature coefficient (PTC) thermistors can be used for overcurrent protection. The resistance of the PTC thermistor will reduce the prospective current from the surge generator for the TISP61089QB.

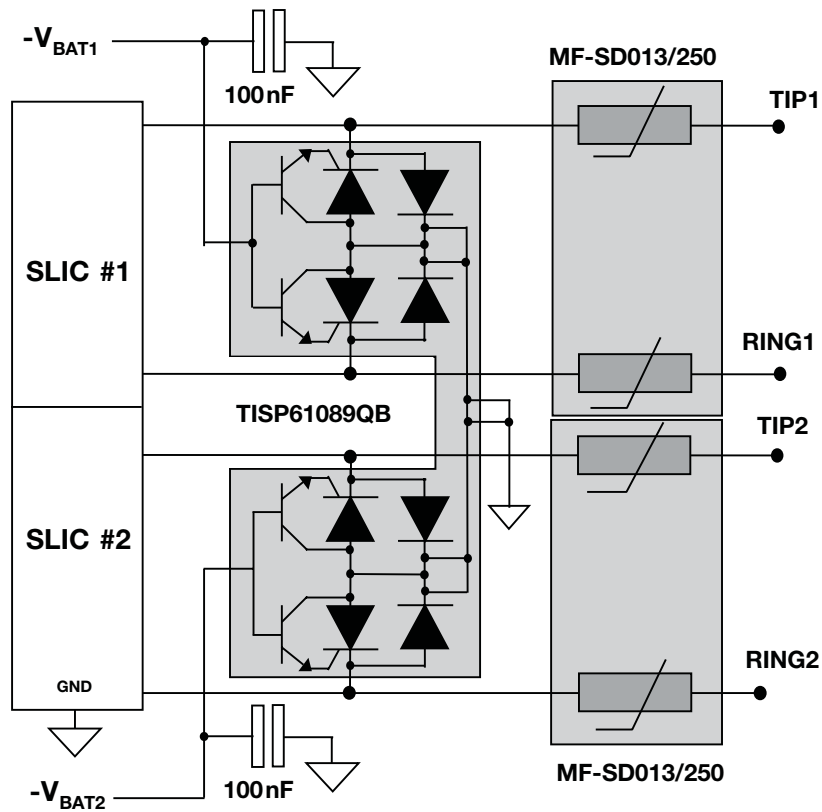

## **Bourns Sales Offices**

<u>Region</u>	<u>Phone</u>	<u>Fax</u>
The Americas:	+1-951-781-5500	+1-951-781-5700
Europe:	+41(0)41-7685555	+41(0)41-7685510
Asia-Pacific:	+886-2-25624117	+886-2-25624116

## **Technical Assistance**

<u>Region</u>	<u>Phone</u>	<u>Fax</u>
The Americas:	+1-951-781-5500	+1-951-781-5700
Europe:	+41(0)41-7685555	+41(0)41-7685510
Asia-Pacific:	+886-2-25624117	+886-2-25624116

**[www.bourns.com](http://www.bourns.com)**

Bourns® products are available through an extensive network of manufacturer's representatives, agents and distributors. To obtain technical applications assistance, a quotation, or to place an order, contact a Bourns representative in your area.

**BOURNS®**

"TISP" is a registered trademark of Bourns Ltd., a Bourns Company, in the United States and other countries, except that "TISP" is a registered trademark of Bourns, Inc. in China.  
"Bourns" is a registered trademark of Bourns, Inc. in the U.S. and other countries.

Компания «Океан Электроники» предлагает заключение долгосрочных отношений при поставках импортных электронных компонентов на взаимовыгодных условиях!

Наши преимущества:

- Поставка оригинальных импортных электронных компонентов напрямую с производств Америки, Европы и Азии, а так же с крупнейших складов мира;
- Широкая линейка поставок активных и пассивных импортных электронных компонентов (более 30 млн. наименований);
- Поставка сложных, дефицитных, либо снятых с производства позиций;
- Оперативные сроки поставки под заказ (от 5 рабочих дней);
- Экспресс доставка в любую точку России;
- Помощь Конструкторского Отдела и консультации квалифицированных инженеров;
- Техническая поддержка проекта, помощь в подборе аналогов, поставка прототипов;
- Поставка электронных компонентов под контролем ВП;
- Система менеджмента качества сертифицирована по Международному стандарту ISO 9001;
- При необходимости вся продукция военного и аэрокосмического назначения проходит испытания и сертификацию в лаборатории (по согласованию с заказчиком);
- Поставка специализированных компонентов военного и аэрокосмического уровня качества (Xilinx, Altera, Analog Devices, Intersil, Interpoint, Microsemi, Actel, Aeroflex, Peregrine, VPT, Syfer, Eurofarad, Texas Instruments, MS Kennedy, Miteq, Cobham, E2V, MA-COM, Hittite, Mini-Circuits, General Dynamics и др.);

Компания «Океан Электроники» является официальным дистрибьютором и эксклюзивным представителем в России одного из крупнейших производителей разъемов военного и аэрокосмического назначения «JONHON», а так же официальным дистрибьютором и эксклюзивным представителем в России производителя высокотехнологичных и надежных решений для передачи СВЧ сигналов «FORSTAR».



## JONHON

«JONHON» (основан в 1970 г.)

Разъемы специального, военного и аэрокосмического назначения:

(Применяются в военной, авиационной, аэрокосмической, морской, железнодорожной, горно- и нефтедобывающей отраслях промышленности)

«FORSTAR» (основан в 1998 г.)

ВЧ соединители, коаксиальные кабели,  
кабельные сборки и микроволновые компоненты:

(Применяются в телекоммуникациях гражданского и специального назначения, в средствах связи, РЛС, а так же военной, авиационной и аэрокосмической отраслях промышленности).



Телефон: 8 (812) 309-75-97 (многоканальный)

Факс: 8 (812) 320-03-32

Электронная почта: [ocean@oceanchips.ru](mailto:ocean@oceanchips.ru)

Web: <http://oceanchips.ru/>

Адрес: 198099, г. Санкт-Петербург, ул. Калинина, д. 2, корп. 4, лит. А