



LC824204-13YB

4:1 Micro USB Switch with Accessory detection and OVP

ON Semiconductor®

<http://onsemi.com>

Overview

The LC824204-13YB is the IC suitable for use in multi function and high performance switch as well as compatible accessory detector which supports micro USB connector for DSC, DVC and mobile phone.

This IC includes low impedance USB supply switch (100 mΩ) which enables high speed battery charge as well as USB2.0-capable switch with low input capacitance, negative input-capable low distortion audio switch, UART, microphone (Mono, Stereo), and various video signal switches.

Also, this IC integrates auto detector for accessories which is capable of detecting accessories compliant to CEA936-A automotive kit and ACA standard which includes MCPC standard established in June 2010. In addition, it's capable of detecting a lot of charger accessories, such as Dedicated (D+/D- short) charger, Apple charger, SONY charger, USB charger and so on. Switching operation is controlled via I²C serial interface.

Function

- Configuration
 - Audio-SW (Mono/Stereo, Negative signal capable)
 - USB2.0-SW (LowSpeed/FullSpeed/HighSpeed-capable)
 - UART-SW
 - Video-SW (Video + V_Audio-R/L)
 - MIC-SW (DP/VBUS switch, Mono/Stereo-capable)
 - VBUS-SW
 - High speed battery charge –capable (100mΩ)
 - Integrated OVP, OCP, TSD
 - DP/DM short-circuit detection, VBUS auto detection
 - Various charger detection (Dedicated, Apple, SONY, USB)
 - ID detection function
 - Integrated 5-bit ADC
 - I²C Interrupt function
- Package
 - WLCSP Pin25, 2.07 mm × 2.07 mm, 0.4 mm pitch
 - Halogen-free, lead-free-capable
- Operating temperature
 - -30 to 85°C
- Supply voltage
 - VDD : 3.0 to 3.6 V
 - VBUS : 4.5 to 5.5 V
- ID detection for the accessories
 - MCPC standard, CEA936-A automotive kit standard, ACA standard-compliant
- Application
 - DSC, DVC, mobile phone

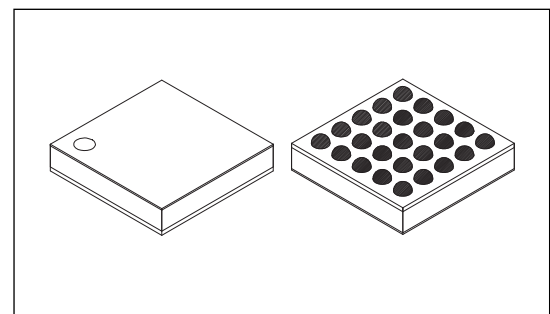

WLP25(2.07X2.07)

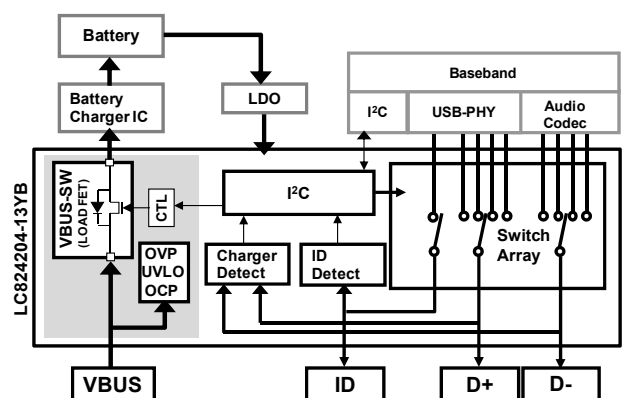

Application Diagram

ORDERING INFORMATION

See detailed ordering and shipping information on page 14 of this data sheet.

LC824204-13YB

Block Diagram

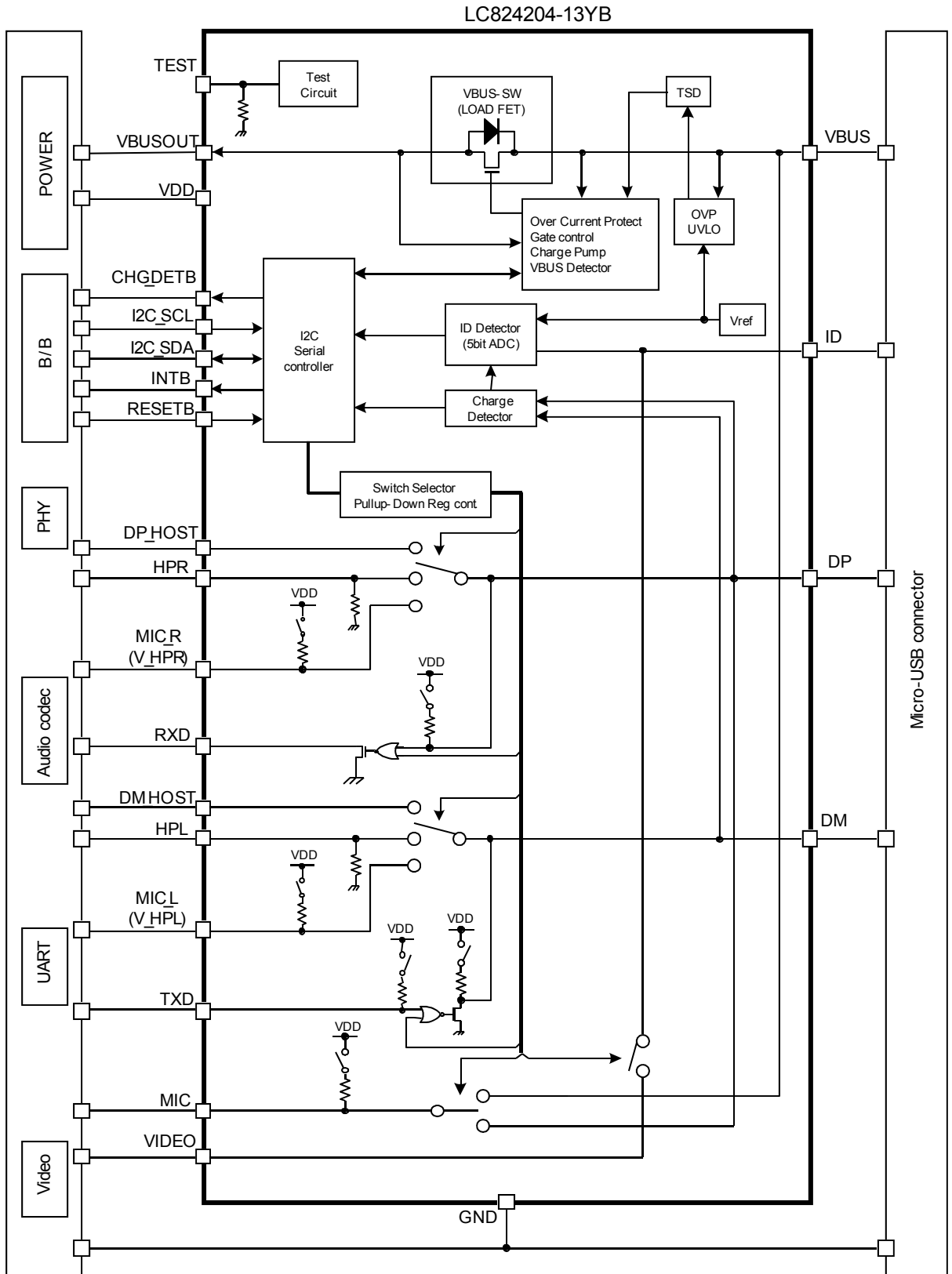

LC824204-13YB

Pin Assignment

Top Through View					
A	VDD	VBUSOUT	VBUSOUT	VBUS	VBUS
B	I2C_SDA	MIC_L (V_HPL)	HPL	DM_HOST	DM
C	I2C_SCL	MIC_R (V_HPR)	HPR	DP_HOST	DP
D	INTB	CHG _DET	MIC	VIDEO	ID
E	RXD	TXD	TEST	RESETB	GND
	1	2	3	4	5

Pin Description

Ball No.	Name	Direction	Description
1A	VDD	P	Power Supply for SW-IC
4A,5A	VBUS	P/I	Power Supply for USB and Battery, MIC input
5E	GND	P	Ground
2A,3A	VBUSOUT	O	Output from VBUS
5D	ID	I/O	ID input, Video output
2D	CHG_DET	O	Charger Detection output*
5C	DP	I/O	USB bath/Audio output, MIC/MIC_R input, UART output*
5B	DM	I/O	USB bath/Audio output, MIC_L input, UART input
4B	DM_HOST	I/O	USB differential data I/O minus
4C	DP_HOST	I/O	USB differential data I/O plus
3C	HPR	I	Audio Right input (Video Audio Right input)
3B	HPL	I	Audio Left input (Video Audio Left input)
1E	RXD	O	UART receive data output*
2E	TXD	I	UART transmission data input
3D	MIC	O	MIC output
4D	VIDEO	I	Video input
2C	MIC_R (V_HPR)	I/O	Stereo MIC R output (Video Audio Right input)
2B	MIC_L (V_HPL)	I/O	Stereo MIC L output (Video Audio Left input)
1C	I2C_SCL	I	I ² C Serial Clock signal
1B	I2C_SDA	I/O	I ² C Serial Data signal*
1D	INTB	O	Interrupt signal*
4E	RESETB	I	Hard Reset input (Low active)
3E	TEST	I	Test pin

Notice) If Video function is not needed, please use the port of Video as NC pins.

LC824204-13YB

Absolute Maximum Ratings at Ta = 25°C

Parameter		Ratings	Unit	
Maximum supply voltage	VDD	-0.3 to 4.6	V	
	VBUS	-0.3 to 28.0	V	
Maximum input /output voltage	DP/DM pin ↔ Signal pin	USB_Path	-0.5 to 4.6	V
		UART_Path	-0.3 to 4.6	V
		AUDIO_Path	-1.5 to 4.6	V
		AUDIO Input Range	3.0	Vpp
		MIC(DP)_Path	-0.5 to 4.6	V
		MIC(DP) Input Range	2.0	Vpp
	VBUS ↔ MIC Pin	MIC(VBUS)_Path	-0.3 to 4.6	V
		MIC(VBUS) Input Range	2.0	Vpp
	DP/DM pin ↔ Signal pin	Stereo-MIC_Path	-0.5 to 4.6	V
		Stereo-MIC Input Range	2.0	Vpp
	VIDEO pin ↔ ID pin	VIDEO_Path	-1.5 to 4.6	V
		VIDEO Input Range	3.0	Vpp
Maximum input/output voltage	VBUSOUT (Output Only)	-0.3 to 6.0	V	
	Others ¹⁾	-0.3 to 4.6	V	
Allowable loss ²⁾	Pd (Ta = 25°C)	690	mW	
Operating temperature range	Topr	-30 to +85	°C	
Storage temperature range	Tstg	-55 to +125	°C	

Stresses exceeding Maximum Ratings may damage the device. Maximum Ratings are stress ratings only. Functional operation above the Recommended Operating Conditions is not implied. Extended exposure to stresses above the Recommended Operating Conditions may affect device reliability.

*1) The Others means I2C_SCL, I2C_SDA, INTB, RESETB, CHG_DET, and TEST pin.

*2) The values were obtained with glass epoxy board of 50 x 40 x 0.9t mm.

Recommended Operating Conditions at Ta = 25°C

Parameter	Symbol	Min	Max	Unit	Condition
VDD voltage	VDD	3.0	3.6	V	
VBUS voltage	VBUS	4.5	5.5	V	
AUDIO input range	VSW_AUDIO	-1.4	1.4	V	
MIC(DP) input range	VSW_MICDP	0	2.5	V	bias < 2.0 V, 1.0 Vpp
MIC(VBUS) input range	VSW_MICVBUS	0	2.5	V	bias < 2.0 V, 1.0 Vpp
Stereo-MIC input range	VSW_SMIC	0	2.5	V	bias < 2.0 V, 1.0 Vpp
VIDEO input range	VSW_VIDEO	-1.4	1.4	V	1.0 Vpp
USB input range	VUSBIn	0	3.6	V	
Other signal input *	Vin	0	VDD	V	
Allowed capacitance of load of accessory ID pin	IDcap		300	pF	

* Other signal input signifies I2C_SCL, I2C_SDA, RESETB, TEST, TXD and RX (DP) pin.

LC824204-13YB

Electrical Characteristics at Ta = 25°C

Parameter	Symbol	Conditions	Min	Typ	Max	Unit
■VDD Current Consumption						
Sleep Mode Current	IDDS2	VBUS = open, RESETB = 0 V → VDD, I2C_SCL = I2C_SDA = VDD, TEST = 0 V, Others_pin = open	-	50	60	μA
Active Mode Current (Audio + VBUS MIC-mode)	IDD1	AUDIO-mode (288k) VBUS = open, RESETB = VDD, I2C_SCL = I2C_SDA = VDD, TEST = 0 V, Others_pin = open	-	80	100	μA
Active Mode Current (USB mode)	IDD2	USB-mode(open) VBUS = 5.0 V, RESETB = VDD, I2C_SCL = I2C_SDA = VDD, TEST = 0 V, Others_pin = open	-	80	100	μA
■AUDIO-SW						
Signal Range	VIN_LR		-1.4	-	1.4	V
AUDIO_SW ON Resistance	RLR	HPR/HPL = -10 mA, DP/DM = -1.3 V, Calculated by R = V / 0.01	-	6.5	12	Ω
Pull Down Resistance	RHPLR		30	50	70	kΩ
■USB-SW						
Signal Range	VIN_USB		0	-	3.6	V
USB_SW ON Resistance	RONUSB	DP/DM = 0 V, DP_HOST/DM_HOST SINK = 10 mA, Calculated by R = V / 0.01		3.2	5	Ω
■MIC-SW (DP Input)						
Signal Range	VIN_MIC1	Vbias < 2.0 V, VSW_MICDP = 1.0 Vpp	0	-	2.5	V
MIC_SW ON Resistance	RMIC1	DP = 0.1 V, MIC = -10 mA, Calculated by R = V / 0.01	-	7.5	15	Ω
Pull Down Resistance	RPUMIC1		1.2	2.2	3.2	kΩ
■MIC-SW (VBUS Input)						
Signal Range	VIN_MIC2	Vbias < 2.0 V, VSW_MICB = 1.0 Vpp	0	-	2.5	V
MIC_SW ON Resistance	RMIC2	VBUS = 0.1 V, MIC = -10 mA, Calculated by R = V / 0.01	-	7.5	15	Ω
Pull Down Resistance	RPUMIC2		1.2	2.2	3.2	kΩ
■StereoMIC-SW (include DP_MIC)						
Signal Range	VIN_MIC3	Vbias < 2.0 V, VSW_SMIC = 1.0 Vpp	0	-	2.5	V
MIC_SW ON Resistance	RMIC3	DP/DM = 0.1 V, MIC_R/MIC_L = -10 mA, Calculated by R = V / 0.01	-	7.5	15	Ω
Pull Down Resistance	RPUMIC3		1.2	2.2	3.2	kΩ
■VIDEO-SW						
Signal Range	VIN_V	VSW_VIDEO = 1.0 Vpp	-1.4	-	1.4	V
VIDEO_SW ON Resistance	RV	Video = -1.4 V, ID = -10 mA, Calculated by R = V / 0.01	-	4	8	Ω

LC824204-13YB

Electrical Characteristics at Ta = 25°C

Parameter	Symbol	Conditions	Min	Typ	Max	Unit
-----------	--------	------------	-----	-----	-----	------

■ UART-SW

TX (DM)						
Low Level Output Voltage	VOL_TX	SINK = 1 mA	-	-	0.4	V
Pull Up Resistance	RTX		5	10	15	kΩ
TXD						
High Level Input Voltage	VIHTXD		1.5	-	-	V
Low Level Input Voltage	VILTXD		-	-	0.7	V
Pull Up Resistance	RTXD		5	10	15	kΩ
RX (DP)						
High Level Input Voltage	VIHRX		1.5	-	-	V
Low Level Input Voltage	VILRX		-	-	0.7	V
Pull Up Resistance	RRX		5	10	15	kΩ
RXD						
Low Level Output Voltage	VOL_RXD	SINK = 1 mA	-	-	0.4	V

■ VBUS-SW

VBUS_SW ON Resistance	RVBUS	VBUS = 5.0 V, VBUSOUT = -300 mA, Calculated by $R = V / 0.3$	-	100	250	mΩ
UVL Cancel Voltage	VVBUSH_DET	VDD = 3.3 V, VBUS = upper	3.8	4.0	4.2	V
UVL Detect Voltage	VVBUSL_DET	VDD = 3.3 V, VBUS = lower	3.0	3.2	3.4	V
OVP Threshold Voltage	VOVP	VDD = 3.3 V, VBUS = upper & lower	5.8	6.0	6.4	V
Charging Current	ICL2	VBUS_ILIMIT = Mid	420	-	(700)	mA
	ICL3	VBUS_ILIMIT = High	650	-	(1050)	mA
	ICL4	VBUS_ILIMIT = Super	1500	-	-	mA

■ I2C_SCL, I2C_SDA

High Level Input Voltage	VIH_I2C		1.5	-	VDD+0.5	V
Low Level Input Voltage	VIL_I2C		-0.3	-	0.3	V
Hysteresis of inputs	VHYS_I2C		0.05*VDD	-	-	V

■ RESETB, TEST

High Level Input Voltage	VIH_IO		1.5	-	-	V
Low Level Input Voltage	VIL_IO		-	-	0.3	V

■ I2C_SDA, INTB, CHG_DET

Low Level Output Voltage	VOL_I2C	SINK = 3 mA	-	-	0.4	V
--------------------------	---------	-------------	---	---	-----	---

Function Description

Charger Detection

By using charger detector circuit including built-in D+/D- short-circuit detector, you can judge the connection of DP pin and DM pin and then detect charger according to USB Charger and Battery Charging Specification Revision 1.1 as well as CEA936-A automotive kit specification. This IC can detect the charger of the following list.

Detectable charger list
Standard Downstream Port (USB mode)
Dedicated Charging Port (D+/D- short ACC)
Apple Charger
SONY Charger
D- High Charger (Basic CarKit Type1,2 ACC)
VBUS only ACC (No Charger Detect)

Accessory ID Detection

Accessory is detected according to CEA936-A automotive kit and ACA standard including MCPC standard using ID detection circuit including built-in 5-bit ADC. Accessories are judged from the resistance value of accessory (RID) connected to ID pin. ID range of RID varies depends on each standard. See Resistance (RID) and Detectable accessory for the further details.

Resistance (RID) and Detectable Accessory

RID	Detectable Accessory	Comments
Open	No Accessory	
Open	AC Adapter (Fast Charger)	(D+/D- : Shorted)
Open(over 1M)	USB-Mode	(D+/D- : Not shorted)
750k + 47k (759k to 835k)	Audio with MIC (Mono)	
510k + 47k (531k-583k)	Audio (Mono Earphone) + Charger (Std Charger) + MIC (D+ in)	(D+/D- : Not shorted)
440k (436k-444k)	Fast Charger (Typ2 Charger)	Charger 5Wire/Type2 (D+/D- : Shorted)
	CarKit (Type2)	BasicCarKit 5Wire/type2 also used for Muting (D- : High)
390k (379k-408k)	Video-Audio	
	Video-Audio with VBUS	(D+/D- : Not shorted)
240k + 47k (275k-294k)	Audio with MIC (Stereo)	
	Audio with VBUS (Stereo)	MIC-SW turns off when VBUS Detection. (D+/D- : Not shorted)

LC824204-13YB

Table of Resistance (RID) and Detectable Accessory

RID	Detectable Accessory	Comments
200k (198k-202k)	Std Charger (Typ1Charger)	Charger 5Wire/Type1 (D+/D- : Shorted)
	Carkit (Type1)	BasicCarkit 5Wire/type1 also used for Muting (D- : High)
150k-180k	UART	
119k-124k-132k	RID_A	ACA A-device (RID_A) Vbus come fm Charger
100k-102k (96k-106k)	Audio (Stereo)	Headset / Stereo
		Phone Powered Accessory (D+/D- : Not shorted)
65k-68k-72k	RID_B	ACA B-device, no connect (RID_B) Vbus come fm Charger can SRP
35k-36.5k-39k	RID_C	ACA B-device, no connect (RID_C) Vbus come fm Charger no SRP
20k	Custom Accessory	
14k	Stereo-MIC with VBUS	D+/D- : Not shorted
11k	Stereo-MIC	
7k	Custom Accessory with VBUS	D+/D- : Not shorted
4k	Custom Accessory	
3.1k	Custom Accessory with VBUS	D+/D- : Not shorted
2.5k	Custom Accessory	
1.7k	Custom Accessory with VBUS	D+/D- : Not shorted
75	Video	
	Video with VBUS	D+/D- : Not shorted
0-10	USB-OTG Host	

LC824204-13YB

Table of Resistance (RID) and Selecting switch.

RID	Detectable Accessory	SW Selection								
		VBUS	USB	AUDIO_R	AUDIO_L	UART	MIC_VBUS	MIC_D+	VIDEO	Stereo-MIC
Open	No Accessory	OFF	OFF	OFF	OFF	OFF	OFF	OFF	OFF	OFF
	AC Adapter (Fast Charger)	ON	OFF	OFF	OFF	OFF	OFF	OFF	OFF	OFF
	USB-Mode	ON	ON	OFF	OFF	OFF	OFF	OFF	OFF	OFF
750k + 47k	Audio (with MIC) (Mono)	OFF	OFF	OFF	ON	OFF	ON	OFF	OFF	OFF
510k + 47k	Audio (Mono Earphone) +Charger (Std Charger) +MIC (D+ in)	ON	OFF	OFF	ON	OFF	OFF	ON	OFF	OFF
440k	Fast Charger (Typ2Charger)	ON	OFF	OFF	OFF	OFF	OFF	OFF	OFF	OFF
	Carkit (Type2)	ON	OFF	OFF	OFF	OFF	OFF	OFF	OFF	OFF
390k	Video-Audio	OFF	OFF	ON	ON	OFF	OFF	OFF	ON	OFF
	Video-Audio with VBUS	ON	OFF	ON	ON	OFF	OFF	OFF	ON	OFF
240k + 47k	Audio with MIC (Stereo)	OFF	OFF	ON	ON	OFF	ON	OFF	OFF	OFF
	Audio with VBUS (Stereo)	ON	OFF	ON	ON	OFF	OFF	OFF	OFF	OFF
200k	Std Charger (Typ1Chager)	ON	OFF	OFF	OFF	OFF	OFF	OFF	OFF	OFF
	Carkit (Type1)	ON	OFF	OFF	OFF	OFF	OFF	OFF	OFF	OFF
150k-180k	UART	OFF	OFF	OFF	OFF	ON	OFF	OFF	OFF	OFF
119k-124k-132k	RID_A	ON	ON	OFF	OFF	OFF	OFF	OFF	OFF	OFF
100k-102k	Audio (Stereo) :Headset / Stereo	OFF	OFF	ON	ON	OFF	OFF	OFF	OFF	OFF
	Audio (Stereo) Phone Powered Accessory ^{*1)}	OFF	OFF	ON	ON	OFF	OFF	OFF	OFF	OFF
65k-68k-72k	RID_B	ON	OFF	OFF	OFF	OFF	OFF	OFF	OFF	OFF
35k-36.5k-39k	RID_C	ON	ON	OFF	OFF	OFF	OFF	OFF	OFF	OFF
20k	Custom Accessory ^{*2)}	-	-	-	-	-	-	-	-	-
14k	Custom Accessory with VBUS ^{*2)}	-	-	-	-	-	-	-	-	-
11k	Stereo-MIC	OFF	OFF	OFF	OFF	OFF	OFF	OFF	OFF	ON
7k	Custom Accessory with VBUS ^{*2)}	-	-	-	-	-	-	-	-	-
4k	Custom Accessory ^{*2)}	-	-	-	-	-	-	-	-	-
3.1k	Custom Accessory with VBUS ^{*2)}	-	-	-	-	-	-	-	-	-
2.5k	Custom Accessory ^{*2)}	-	-	-	-	-	-	-	-	-
1.7k	Custom Accessory with VBUS ^{*2)}	-	-	-	-	-	-	-	-	-
75	VIDEO	OFF	OFF	ON	ON	OFF	OFF	OFF	ON	OFF
	VIDEO with VBUS	ON	OFF	ON	ON	OFF	OFF	OFF	ON	OFF
0-10	USB-OTG Host ^{*1)}	OFF	ON	OFF	OFF	OFF	OFF	OFF	OFF	OFF

Note *1) You can only detect RID (you cannot select SW).

Note *2) Custom Accessory : User can define SW selection.

I²Cbus timing (serial I/F)

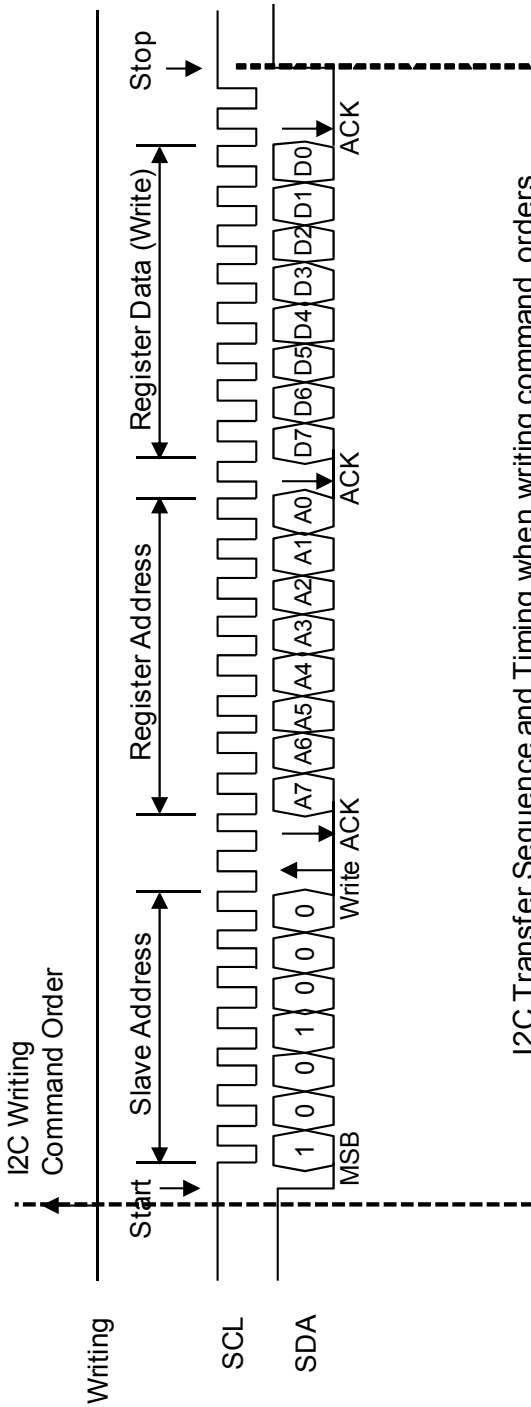

I2C Transfer Sequence and Timing when writing command orders

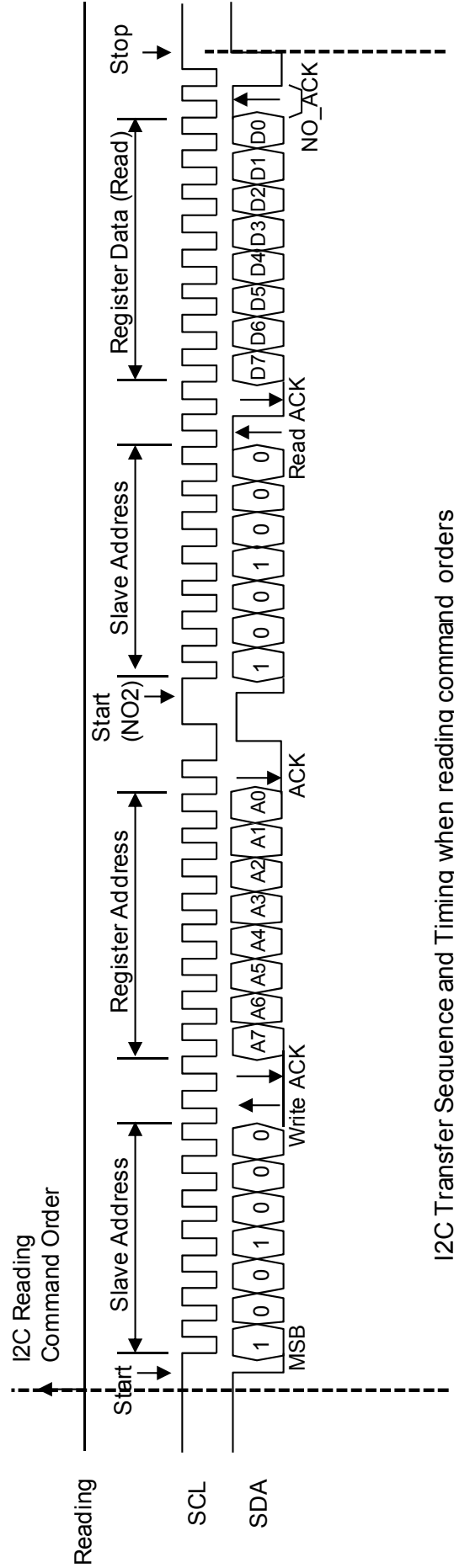

I2C Transfer Sequence and Timing when reading command orders

LC824204-13YB

*I²Cbus timing

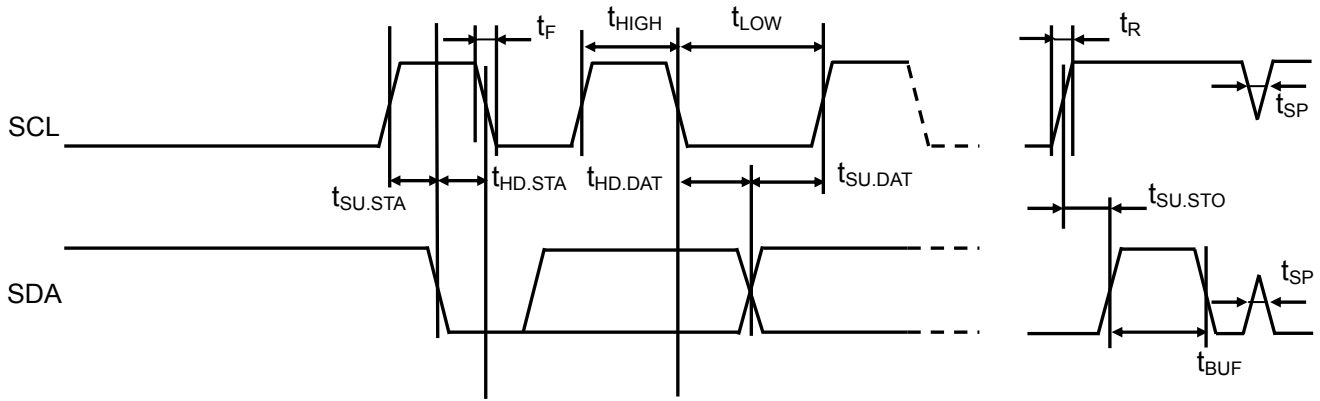

Symbol	Parameter	Min	Max	Unit
tSCL	SCL clock fr.	0	400	kHz
tBUF	Bus release period	1.3		μs
tHD:STA	Hold time (Start)	0.6		μs
tLOW	SCL_Lo period	1.3		μs
tHIGH	SCL_Hi period	0.6		μs
tR	Rise time		300	ns
tF	Fall time		300	ns
tSU:STA	Setup time (Start)	0.6		μs
tSU:STO	Setup time (Stop)	0.6		μs
tSU:DAT	Setup time (Data)	100		ns
tHD:DAT	Hold time (Data)	0		ns
tSP	Removable spike width		50	ns

I²C system reset

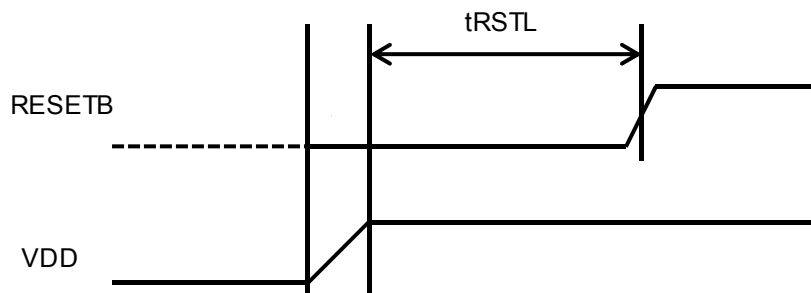

Symbol	Parameter	Min	Max	Unit
tRSTL ^{*1)}	resetLow time	5		μs

* 1) RESETB is the reset signal of the group of register by I²C. Therefore, you need Low period for tRSTL after powering VDD.

I/O Equivalent Circuit

PortName	Circuit	PortName	Circuit
VBUS VBUSOUT		HPL HPR	
ID		MIC_L (V_HPL) MIC_R (V_HPR) MIC VIDEO	
RXD		DP DM DP_HOST DM_HOST	
TXD		INTB	
I2C_SCL		I2C_SDA	
CHG_DET		RESETB	
TEST			

Application Circuit Example

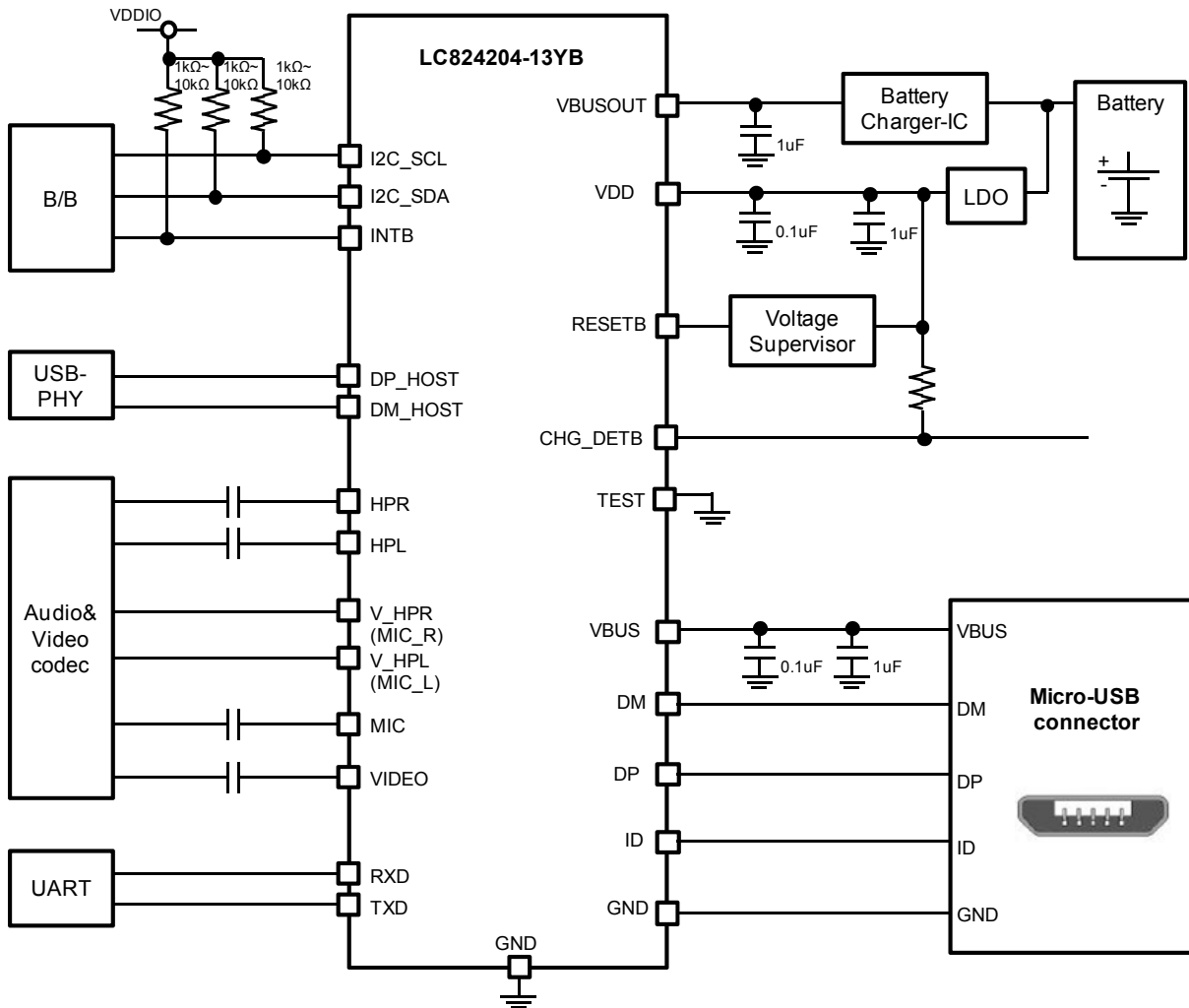

Caution:

- (1) Connect a capacitor higher than 1 μF to VBUSOUT
- (2) Pull Up supply for CHG_DETB (open drain) should be the same VDD as the LSI. Since Pch protector diode is connected to CHG_DETB, when VDD is OFF, latch up may occur when the signal level turns high by the pull up.
- (3) Make sure to connect capacitor (C cut) to VIDEO pin.
- (4) TEST should be either GND or Open.

LC824204-13YB

Package Dimensions

WLCSP 25pin 2.07 mm × 2.07 mm, 0.4 mm pitch
unit : mm

WLCSP25 2.07x2.07 / WLP25
CASE 567EF
ISSUE O

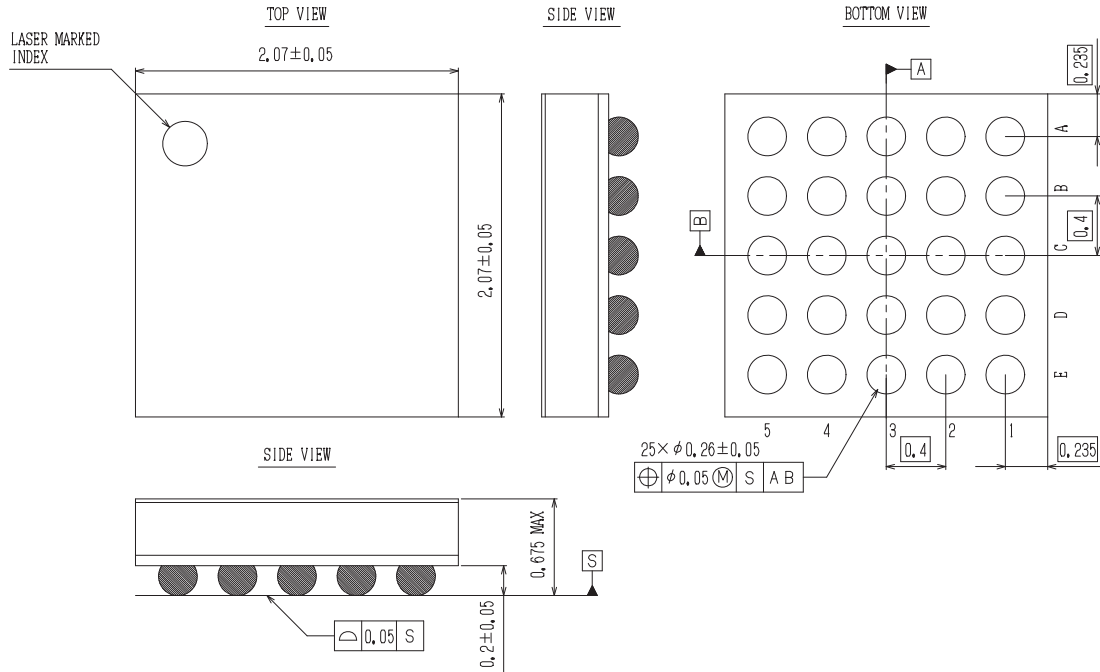

ORDERING INFORMATION

Device	Package	Shipping (Qty / Packing)
LC824204-13YB-VH	WLP25(2.07X2.07) (Pb-Free / Halogen Free)	4000 / Tape & Reel

ON Semiconductor and the ON logo are registered trademarks of Semiconductor Components Industries, LLC (SCILLC). SCILLC owns the rights to a number of patents, trademarks, copyrights, trade secrets, and other intellectual property. A listing of SCILLC's product/patent coverage may be accessed at www.onsemi.com/site/pdf/Patent-Marking.pdf. SCILLC reserves the right to make changes without further notice to any products herein. SCILLC makes no warranty, representation or guarantee regarding the suitability of its products for any particular purpose, nor does SCILLC assume any liability arising out of the application or use of any product or circuit, and specifically disclaims any and all liability, including without limitation special, consequential or incidental damages. "Typical" parameters which may be provided in SCILLC data sheets and/or specifications can and do vary in different applications and actual performance may vary over time. All operating parameters, including "Typicals" must be validated for each customer application by customer's technical experts. SCILLC does not convey any license under its patent rights nor the rights of others. SCILLC products are not designed, intended, or authorized for use as components in systems intended for surgical implant into the body, or other applications intended to support or sustain life, or for any other application in which the failure of the SCILLC product could create a situation where personal injury or death may occur. Should Buyer purchase or use SCILLC products for any such unintended or unauthorized application, Buyer shall indemnify and hold SCILLC and its officers, employees, subsidiaries, affiliates, and distributors harmless against all claims, costs, damages, and expenses, and reasonable attorney fees arising out of, directly or indirectly, any claim of personal injury or death associated with such unintended or unauthorized use, even if such claim alleges that SCILLC was negligent regarding the design or manufacture of the part. SCILLC is an Equal Opportunity/Affirmative Action Employer. This literature is subject to all applicable copyright laws and is not for resale in any manner.

Компания «Океан Электроники» предлагает заключение долгосрочных отношений при поставках импортных электронных компонентов на взаимовыгодных условиях!

Наши преимущества:

- Поставка оригинальных импортных электронных компонентов напрямую с производств Америки, Европы и Азии, а так же с крупнейших складов мира;
- Широкая линейка поставок активных и пассивных импортных электронных компонентов (более 30 млн. наименований);
- Поставка сложных, дефицитных, либо снятых с производства позиций;
- Оперативные сроки поставки под заказ (от 5 рабочих дней);
- Экспресс доставка в любую точку России;
- Помощь Конструкторского Отдела и консультации квалифицированных инженеров;
- Техническая поддержка проекта, помощь в подборе аналогов, поставка прототипов;
- Поставка электронных компонентов под контролем ВП;
- Система менеджмента качества сертифицирована по Международному стандарту ISO 9001;
- При необходимости вся продукция военного и аэрокосмического назначения проходит испытания и сертификацию в лаборатории (по согласованию с заказчиком);
- Поставка специализированных компонентов военного и аэрокосмического уровня качества (Xilinx, Altera, Analog Devices, Intersil, Interpoint, Microsemi, Actel, Aeroflex, Peregrine, VPT, Syfer, Eurofarad, Texas Instruments, MS Kennedy, Miteq, Cobham, E2V, MA-COM, Hittite, Mini-Circuits, General Dynamics и др.);

Компания «Океан Электроники» является официальным дистрибьютором и эксклюзивным представителем в России одного из крупнейших производителей разъемов военного и аэрокосмического назначения «JONHON», а так же официальным дистрибьютором и эксклюзивным представителем в России производителя высокотехнологичных и надежных решений для передачи СВЧ сигналов «FORSTAR».



JONHON

«JONHON» (основан в 1970 г.)

Разъемы специального, военного и аэрокосмического назначения:

(Применяются в военной, авиационной, аэрокосмической, морской, железнодорожной, горно- и нефтедобывающей отраслях промышленности)

«FORSTAR» (основан в 1998 г.)

ВЧ соединители, коаксиальные кабели, кабельные сборки и микроволновые компоненты:

(Применяются в телекоммуникациях гражданского и специального назначения, в средствах связи, РЛС, а так же военной, авиационной и аэрокосмической отраслях промышленности).



Телефон: 8 (812) 309-75-97 (многоканальный)

Факс: 8 (812) 320-03-32

Электронная почта: ocean@oceanchips.ru

Web: <http://oceanchips.ru/>

Адрес: 198099, г. Санкт-Петербург, ул. Калинина, д. 2, корп. 4, лит. А