



Is Now Part of



**ON Semiconductor®**

To learn more about ON Semiconductor, please visit our website at  
[www.onsemi.com](http://www.onsemi.com)

Please note: As part of the Fairchild Semiconductor integration, some of the Fairchild orderable part numbers will need to change in order to meet ON Semiconductor's system requirements. Since the ON Semiconductor product management systems do not have the ability to manage part nomenclature that utilizes an underscore (\_), the underscore (\_) in the Fairchild part numbers will be changed to a dash (-). This document may contain device numbers with an underscore (\_). Please check the ON Semiconductor website to verify the updated device numbers. The most current and up-to-date ordering information can be found at [www.onsemi.com](http://www.onsemi.com). Please email any questions regarding the system integration to [Fairchild\\_questions@onsemi.com](mailto:Fairchild_questions@onsemi.com).

ON Semiconductor and the ON Semiconductor logo are trademarks of Semiconductor Components Industries, LLC dba ON Semiconductor or its subsidiaries in the United States and/or other countries. ON Semiconductor owns the rights to a number of patents, trademarks, copyrights, trade secrets, and other intellectual property. A listing of ON Semiconductor's product/patent coverage may be accessed at [www.onsemi.com/site/pdf/Patent-Marking.pdf](http://www.onsemi.com/site/pdf/Patent-Marking.pdf). ON Semiconductor reserves the right to make changes without further notice to any products herein. ON Semiconductor makes no warranty, representation or guarantee regarding the suitability of its products for any particular purpose, nor does ON Semiconductor assume any liability arising out of the application or use of any product or circuit, and specifically disclaims any and all liability, including without limitation special, consequential or incidental damages. Buyer is responsible for its products and applications using ON Semiconductor products, including compliance with all laws, regulations and safety requirements or standards, regardless of any support or applications information provided by ON Semiconductor. "Typical" parameters which may be provided in ON Semiconductor data sheets and/or specifications can and do vary in different applications and actual performance may vary over time. All operating parameters, including "Typicals" must be validated for each customer application by customer's technical experts. ON Semiconductor does not convey any license under its patent rights nor the rights of others. ON Semiconductor products are not designed, intended, or authorized for use as a critical component in life support systems or any FDA Class 3 medical devices or medical devices with a same or similar classification in a foreign jurisdiction or any devices intended for implantation in the human body. Should Buyer purchase or use ON Semiconductor products for any such unintended or unauthorized application, Buyer shall indemnify and hold ON Semiconductor and its officers, employees, subsidiaries, affiliates, and distributors harmless against all claims, costs, damages, and expenses, and reasonable attorney fees arising out of, directly or indirectly, any claim of personal injury or death associated with such unintended or unauthorized use, even if such claim alleges that ON Semiconductor was negligent regarding the design or manufacture of the part. ON Semiconductor is an Equal Opportunity/Affirmative Action Employer. This literature is subject to all applicable copyright laws and is not for resale in any manner.



# FAN7888

## 3 Half-Bridge Gate-Drive IC

### Features

- Floating Channel for Bootstrap Operation to +200 V
- Typically 350 mA / 650 mA Sourcing/Sinking Current Driving Capability for All Channels
- 3 Half-Bridge Gate Driver
- Extended Allowable Negative  $V_S$  Swing to -9.8 V for Signal Propagation at  $V_{BS}=15$  V
- Matched Propagation Delay Time Maximum: 50 ns
- 3.3 V and 5 V Input Logic Compatible
- Built-in Shoot-Through Prevention Circuit for All Channels with 270 ns Typical Dead Time
- Built-in Common Mode dv/dt Noise Canceling Circuit
- Built-in UVLO Functions for All Channels

### Applications

- 3-Phase Motor Inverter Driver

### Related Resources

- [AN-6076 - Design and Application Guide of Bootstrap Circuit for High-Voltage Gate-Drive IC](#)
- [AN-9052 - Design Guide for Selection of Bootstrap Components](#)
- [AN-8102 - Recommendations to Avoid Short Pulse Width Issues in HVIC Gate Driver Applications](#)

### Description

The FAN7888 is a monolithic three half-bridge gate-drive IC designed for high-voltage, high-speed driving MOS-FETs and IGBTs operating up to +200 V.

Fairchild's high-voltage process and common-mode noise canceling technique provide stable operation of high-side drivers under high-dv/dt noise circumstances.

An advanced level-shift circuit allows high-side gate driver operation up to  $V_S=-9.8$  V (typical) for  $V_{BS}=15$  V.

The UVLO circuits prevent malfunction when  $V_{DD}$  and  $V_{BS}$  are lower than the specified threshold voltage.

Output drivers typically source/sink 350 mA / 650 mA, respectively, which is suitable for three-phase half-bridge applications in motor drive systems.

20-SOIC



### Ordering Information

Part Number	Package	Operating Temperature Range	Packing Method
FAN7888MX	20-SOIC	-40°C to +125°C	Tape & Reel

### Typical Application Circuit

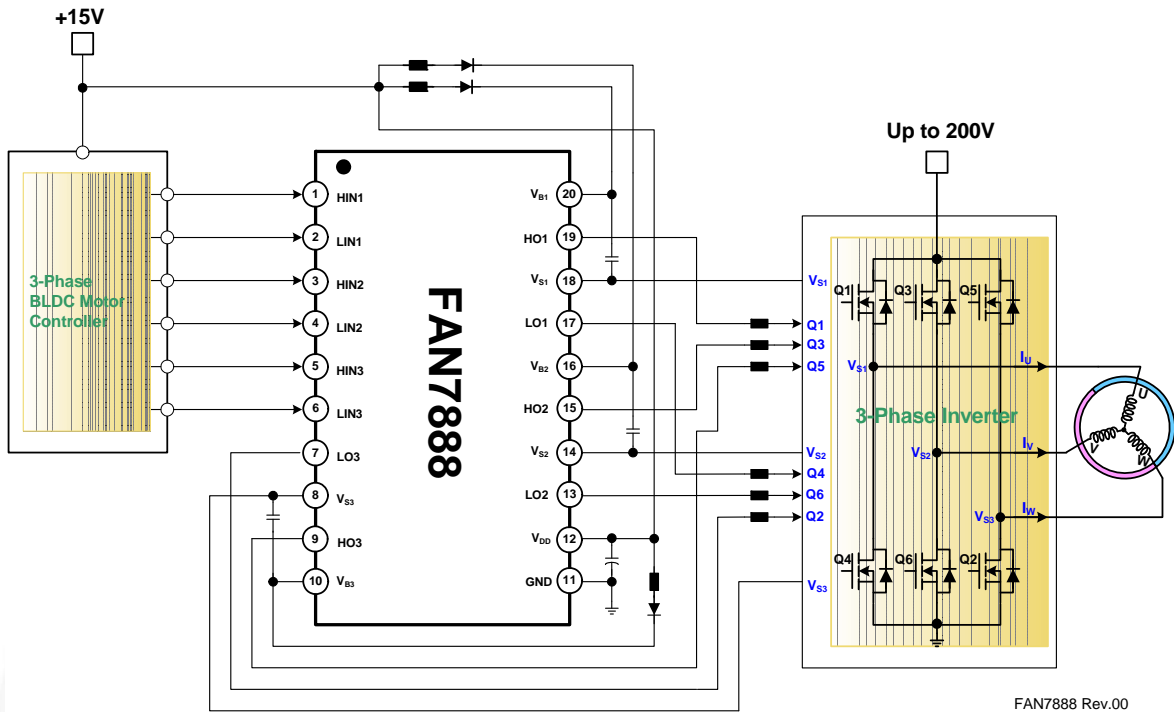

Figure 1. 3-Phase BLDC Motor Drive Application

### Internal Block Diagram

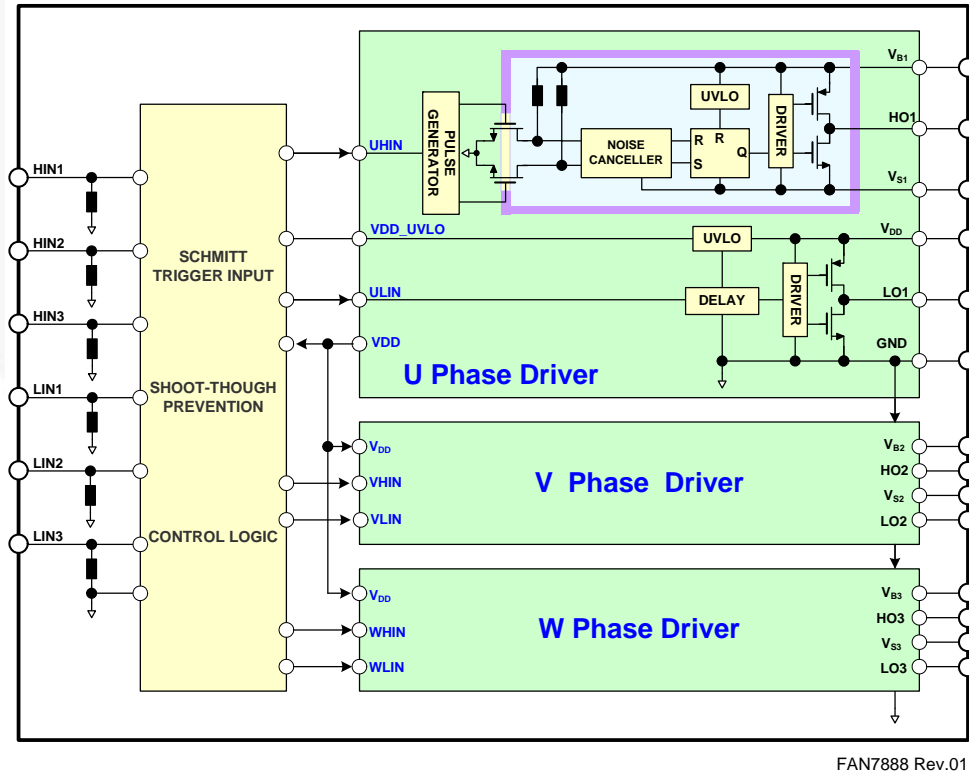
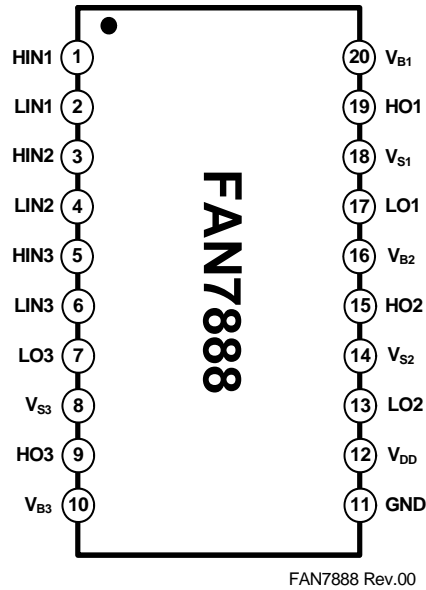

Figure 2. Functional Block Diagram

## Pin Configuration



FAN7888 Rev.00

Figure 3. Pin Configuration (Top View)

## Pin Definitions

Pin #	Name	Description
1	HIN1	Logic input 1 for high-side gate 1 driver
2	LIN1	Logic input 1 for low-side gate 1 driver
3	HIN2	Logic input 2 for high-side gate 2 driver
4	LIN2	Logic input 2 for low-side gate 2 driver
5	HIN3	Logic input 3 for high-side gate 3 driver
6	LIN3	Logic input 3 for low-side gate 3 driver
7	LO3	Low-side gate driver 3 output
8	$V_{S3}$	High-side driver 3 floating supply offset voltage
9	HO3	High-side driver 3 gate driver output
10	$V_{B3}$	High-side driver 3 floating supply voltage
11	GND	Ground
12	$V_{DD}$	Logic and all low-side gate drivers power supply voltage
13	LO2	Low-side gate driver 2 output
14	$V_{S2}$	High-side driver 2 floating supply offset voltage
15	HO2	High-side driver 2 gate driver output
16	$V_{B2}$	High-side driver 2 floating supply voltage
17	LO1	Low-side gate driver 1 output
18	$V_{S1}$	High-side driver 1 floating supply offset voltage
19	HO1	High-side driver 1 gate driver output
20	$V_{B1}$	High-side driver 1 floating supply voltage

## Absolute Maximum Ratings

Stresses exceeding the absolute maximum ratings may damage the device. The device may not function or be operable above the recommended operating conditions and stressing the parts to these levels is not recommended. In addition, extended exposure to stresses above the recommended operating conditions may affect device reliability. The absolute maximum ratings are stress ratings only.  $T_A=25^{\circ}\text{C}$ , unless otherwise specified.

Symbol	Parameter	Min.	Max.	Unit
$V_B$	High-Side Floating Supply Voltage of $V_{B1,2,3}$	-0.3	225.0	V
$V_S$	High-Side Floating Supply Offset Voltage of $V_{S1,2,3}$	$V_{B1,2,3}-25$	$V_{B1,2,3}+0.3$	V
$V_{HO1,2,3}$	High-Side Floating Output Voltage	$V_{S1,2,3}-0.3$	$V_{B1,2,3}+0.3$	V
$V_{DD}$	Low-Side and Logic-fixed Supply Voltage	-0.3	25.0	V
$V_{LO1,2,3}$	Low-Side Output Voltage	-0.3	$V_{DD}+0.3$	V
$V_{IN}$	Logic Input Voltage (HIN1,2,3 and LIN1,2,3)	-0.3	$V_{DD}+0.3$	V
$dV_S/dt$	Allowable Offset Voltage Slew Rate		50	V/ns
$P_D$	Power Dissipation <sup>(1)(2)(3)</sup>		1.47	W
$\theta_{JA}$	Thermal Resistance, Junction-to-ambient		85	$^{\circ}\text{C}/\text{W}$
$T_J$	Junction Temperature		+150	$^{\circ}\text{C}$
$T_{STG}$	Storage Temperature	-55	+150	$^{\circ}\text{C}$

### Notes:

- Mounted on 76.2 x 114.3 x 1.6 mm PCB (FR-4 glass epoxy material).
- Refer to the following standards:
  - JESD51-2: Integral circuits thermal test method environmental conditions - natural convection
  - JESD51-3: Low effective thermal conductivity test board for leaded surface-mount packages.
- Do not exceed  $P_D$  under any circumstances.

## Recommended Operating Conditions

The Recommended Operating Conditions table defines the conditions for actual device operation. Recommended operating conditions are specified to ensure optimal performance to the datasheet specifications. Fairchild does not recommend exceeding them or designing to Absolute Maximum Ratings.

Symbol	Parameter	Min.	Max.	Unit
$V_{B1,2,3}$	High-Side Floating Supply Voltage	$V_{S1,2,3}+10$	$V_{S1,2,3}+20$	V
$V_{S1,2,3}$	High-Side Floating Supply Offset Voltage	$6-V_{DD}$	200	V
$V_{DD}$	Supply Voltage	10	20	V
$V_{HO1,2,3}$	High-Side Output Voltage	$V_{S1,2,3}$	$V_{B1,2,3}$	V
$V_{LO1,2,3}$	Low-Side Output Voltage	GND	$V_{DD}$	V
$V_{IN}$	Logic Input Voltage (HIN1,2,3 and LIN1,2,3)	GND	$V_{DD}$	V
$T_A$	Ambient Temperature	-40	+125	$^{\circ}\text{C}$

## Electrical Characteristics

$V_{BIAS}$  ( $V_{DD}$ ,  $V_{BS1,2,3}$ )=15.0 V,  $T_A=25^\circ\text{C}$ , unless otherwise specified. The  $V_{IN}$  and  $I_{IN}$  parameters are referenced to GND. The  $V_O$  and  $I_O$  parameters are referenced to GND and  $V_{S1,2,3}$  and are applicable to the respective outputs LO1,2,3 and HO1,2,3.

Symbol	Characteristics	Condition	Min.	Typ.	Max.	Unit
<b>LOW-SIDE POWER SUPPLY SECTION</b>						
$I_{QDD}$	Quiescent $V_{DD}$ Supply Current	$V_{LIN1,2,3}=0$ V or 5 V		160	350	$\mu\text{A}$
$I_{PDD1,2,3}$	Operating $V_{DD}$ Supply Current for each Channel	$f_{LIN1,2,3}=20$ kHz, rms Value		500	900	$\mu\text{A}$
$V_{DDUV+}$	$V_{DD}$ Supply Under-Voltage Positive-Going Threshold	$V_{DD}=\text{Sweep}$ , $V_{BS}=15$ V	7.2	8.2	9.0	V
$V_{DDUV-}$	$V_{DD}$ Supply Under-Voltage Negative-Going Threshold	$V_{DD}=\text{Sweep}$ , $V_{BS}=15$ V	6.8	7.8	8.5	V
$V_{DDHYS}$	$V_{DD}$ Supply Under-Voltage Lockout Hysteresis	$V_{DD}=\text{Sweep}$ , $V_{BS}=15$ V		0.4		V
<b>BOOTSTRAPPED POWER SUPPLY SECTION</b>						
$I_{QBS1,2,3}$	Quiescent $V_{BS}$ Supply Current for each Channel	$V_{HIN1,2,3}=0$ V or 5 V		50	120	$\mu\text{A}$
$I_{PBS1,2,3}$	Operating $V_{BS}$ Supply Current for each Channel	$f_{HIN1,2,3}=20$ kHz, rms Value		400	800	$\mu\text{A}$
$V_{BSUV+}$	$V_{BS}$ Supply Under-Voltage Positive-going Threshold	$V_{DD}=15$ V, $V_{BS}=\text{Sweep}$	7.2	8.2	9.0	V
$V_{BSUV-}$	$V_{BS}$ Supply Under-Voltage Negative-going Threshold	$V_{DD}=15$ V, $V_{BS}=\text{Sweep}$	6.8	7.8	8.5	V
$V_{BSHYS}$	$V_{BS}$ Supply Under-Voltage Lockout Hysteresis	$V_{DD}=15$ V, $V_{BS}=\text{Sweep}$		0.4		V
$I_{LK}$	Offset Supply Leakage Current	$V_{B1,2,3}=V_{S1,2,3}=200$ V			10	$\mu\text{A}$
<b>GATE DRIVER OUTPUT SECTION</b>						
$V_{OH}$	High-Level Output Voltage, $V_{BIAS}-V_O$	$I_O=20$ mA			1.0	V
$V_{OL}$	Low-Level Output Voltage, $V_O$	$I_O=20$ mA			0.6	V
$I_{O+}$	Output HIGH Short-Circuit Pulsed Current <sup>(4)</sup>	$V_O=0$ V, $V_{IN}=5$ V with PW <10 $\mu\text{s}$	250	350		mA
$I_{O-}$	Output LOW Short-Circuit Pulsed Current <sup>(4)</sup>	$V_O=15$ V, $V_{IN}=0$ V with PW <10 $\mu\text{s}$	500	650		mA
$V_S$	Allowable Negative $V_S$ Pin Voltage for IN Signal Propagation to $H_O$			-9.8	-7.0	V
<b>LOGIC INPUT SECTION (HIN, LIN)</b>						
$V_{IH}$	Logic "1" Input Voltage		2.5			V
$V_{IL}$	Logic "0" Input Voltage				1.0	V
$I_{IN+}$	Logic "1" Input Bias Current	$V_{IN}=5$ V		25	50	$\mu\text{A}$
$I_{IN-}$	Logic "0" Input Bias Current <sup>(4)</sup>	$V_{IN}=0$ V			2.0	$\mu\text{A}$
$R_{IN}$	Input Pull-Down Resistance		100	200	300	K $\Omega$

### Note:

4. This parameter is guaranteed by design.

## Dynamic Electrical Characteristics

$T_A=25^\circ\text{C}$ ,  $V_{\text{BIAS}} (V_{\text{DD}}, V_{\text{BS1,2,3}})=15.0\text{ V}$ ,  $V_{\text{S1,2,3}}=\text{GND}$ ,  $C_{\text{Load}}=1000\text{ pF}$  unless otherwise specified.

Symbol	Parameter	Conditions	Min.	Typ.	Max.	Unit
$t_{\text{ON}}$	Turn-on Propagation Delay	$V_{\text{S1,2,3}}=0\text{ V}$		130	220	ns
$t_{\text{OFF}}$	Turn-off Propagation Delay	$V_{\text{S1,2,3}}=0\text{ V}$		150	240	ns
$t_{\text{R}}$	Turn-on Rise Time			50	120	ns
$t_{\text{F}}$	Turn-off Fall Time			30	80	ns
MT1	Turn-on Delay Matching   $t_{\text{ON(H)}} - t_{\text{OFF(L)}}  $				50	ns
MT2	Turn-off Delay Matching   $t_{\text{OFF(H)}} - t_{\text{ON(L)}}  $				50	ns
DT	Dead Time		100	270	440	ns
MDT	Dead-time Matching   $t_{\text{DT1}} - t_{\text{DT2}}  $				60	ns

## Typical Characteristics

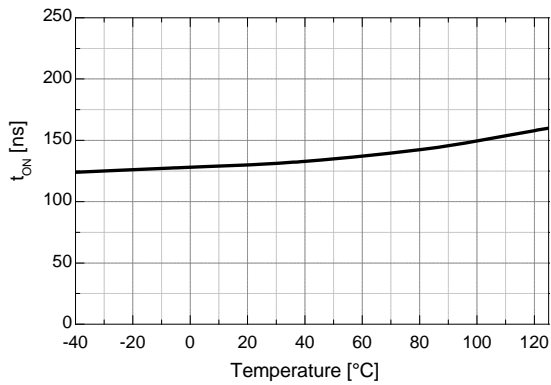

Figure 4. Turn-on Propagation Delay vs. Temp.

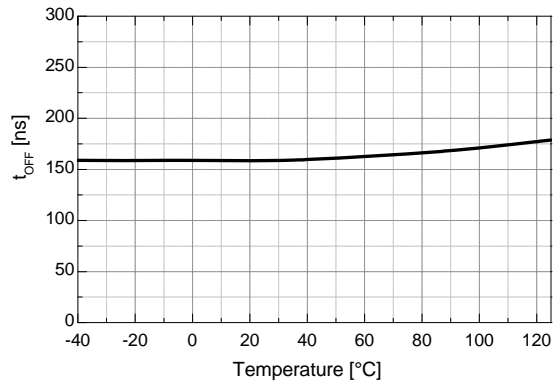

Figure 5. Turn-off Propagation Delay vs. Temp.

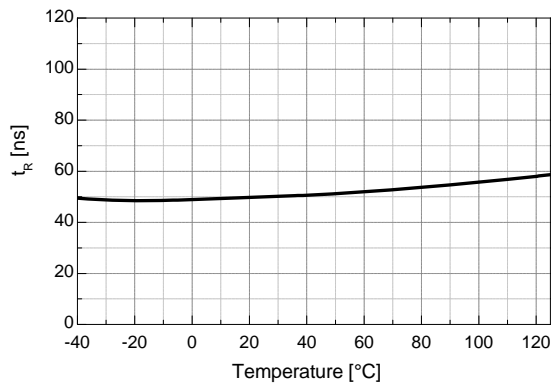

Figure 6. Turn-on Rise Time vs. Temp.

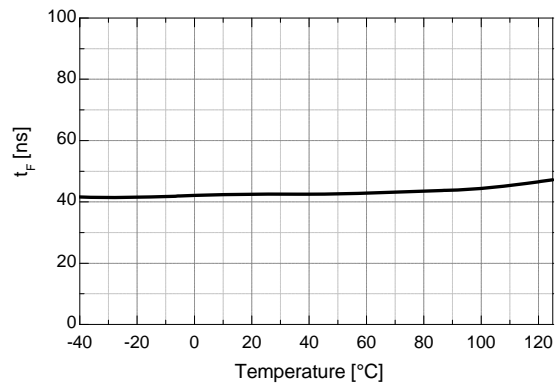

Figure 7. Turn-off Fall Time vs. Temp.

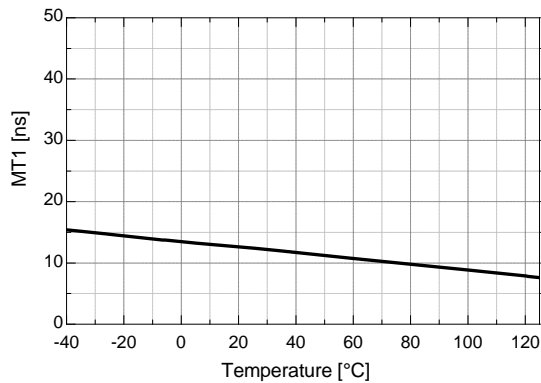

Figure 8. Turn-on Delay Matching vs. Temp.

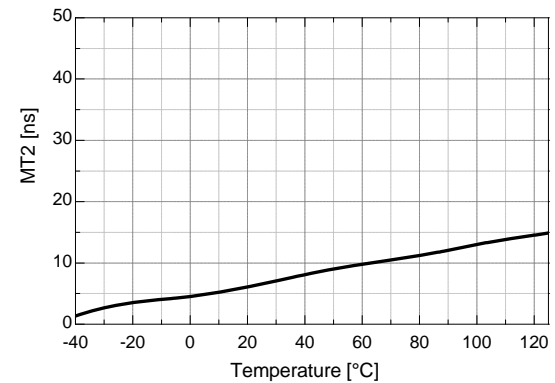

Figure 9. Turn-off Delay Matching vs. Temp.



Typical Characteristics (Continued)

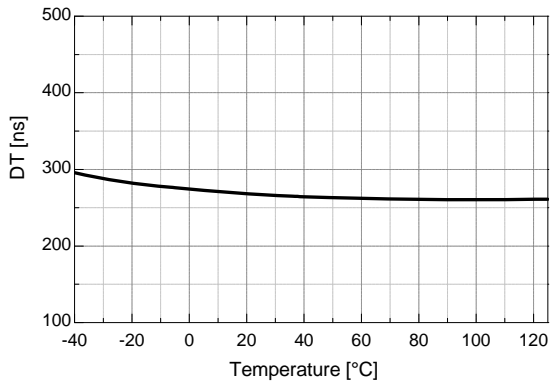

Figure 10. Dead Time vs. Temp.

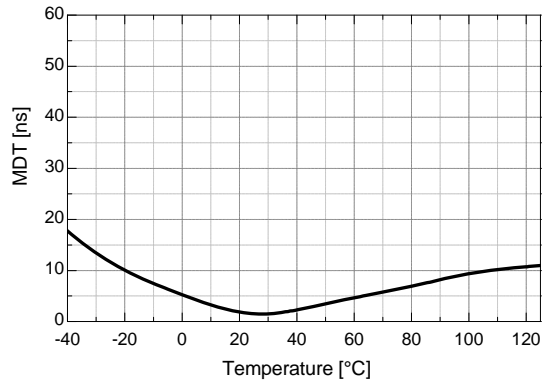

Figure 11. Dead-Time Matching vs. Temp.

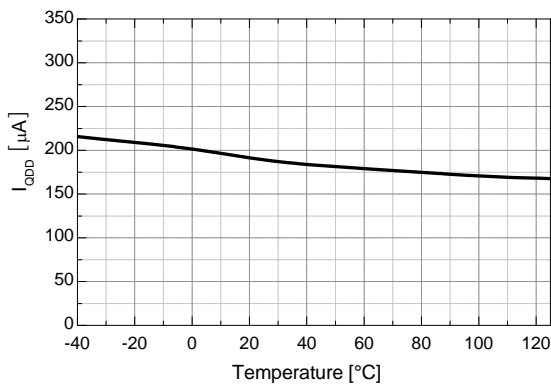

Figure 12. Quiescent V<sub>DD</sub> Supply Current vs. Temp.

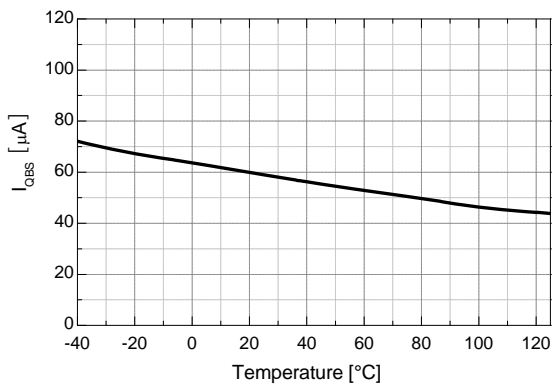

Figure 13. Quiescent V<sub>BS</sub> Supply Current vs. Temp.

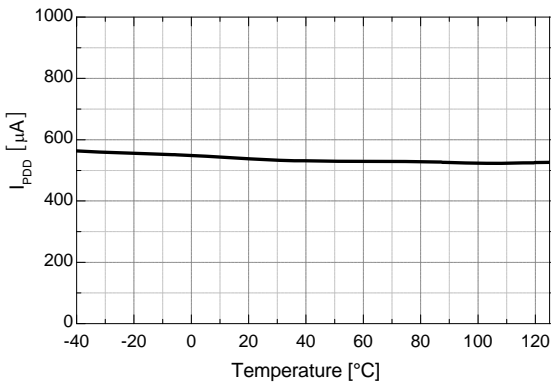

Figure 14. Operating V<sub>DD</sub> Supply Current vs. Temp.

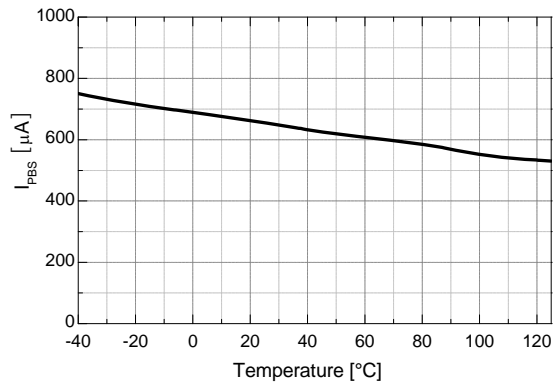

Figure 15. Operating V<sub>BS</sub> Supply Current vs. Temp.

Typical Characteristics (Continued)

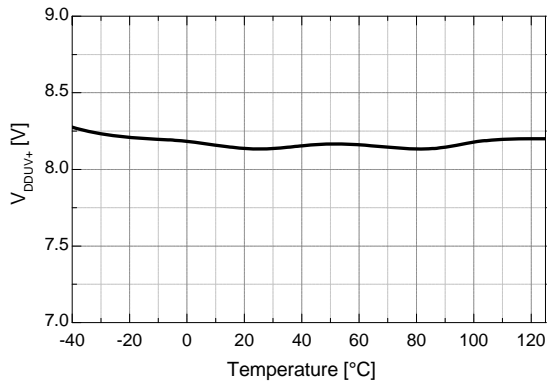

Figure 16. V<sub>DD</sub> UVLO+ vs. Temp.

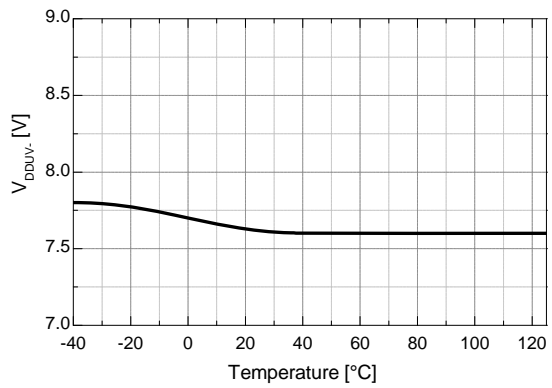

Figure 17. V<sub>DD</sub> UVLO- vs. Temp.

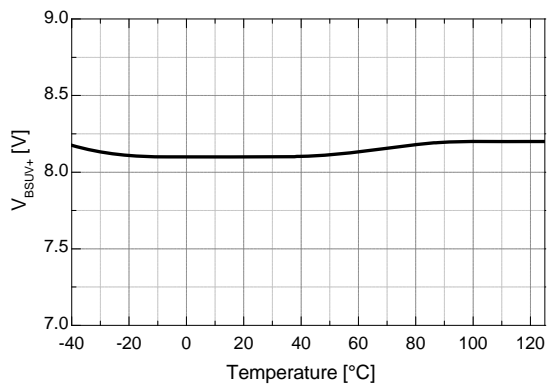

Figure 18. V<sub>BS</sub> UVLO+ vs. Temp.

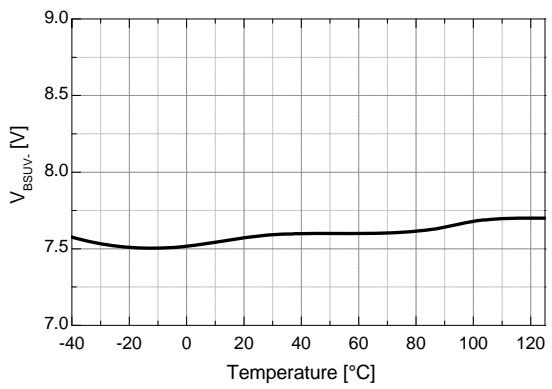

Figure 19. V<sub>BS</sub> UVLO- vs. Temp.

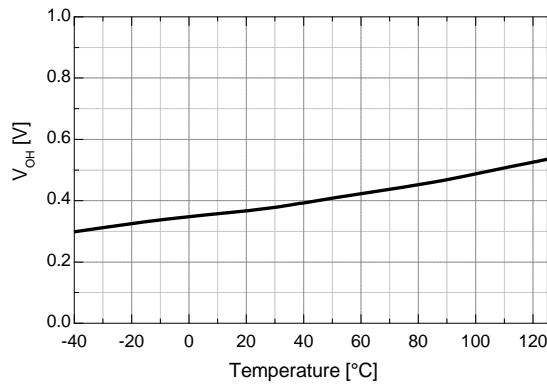

Figure 20. High-Level Output Voltage vs. Temp.

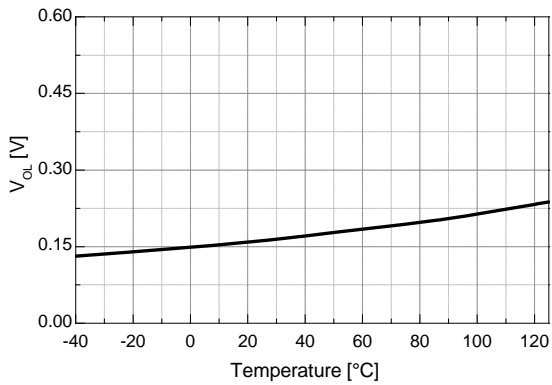

Figure 21. Low-Level Output Voltage vs. Temp.

Typical Characteristics (Continued)

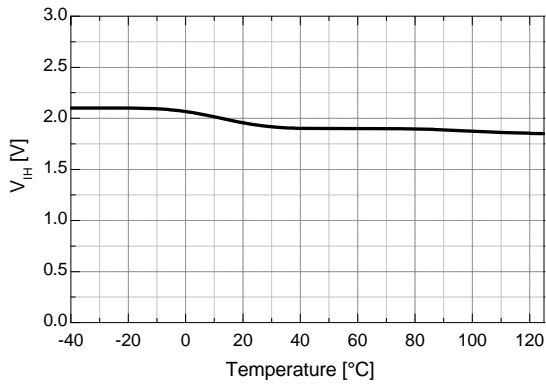

Figure 22. Logic High Input Voltage vs. Temp.

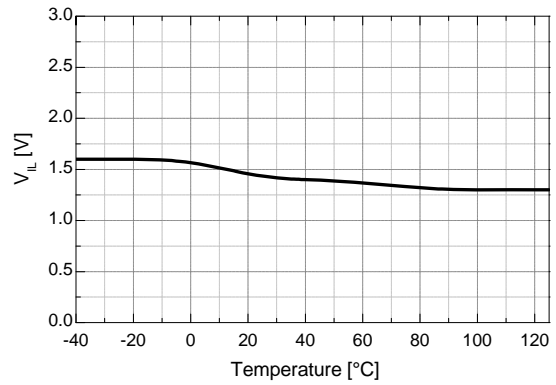

Figure 23. Logic Low Input Voltage vs. Temp.

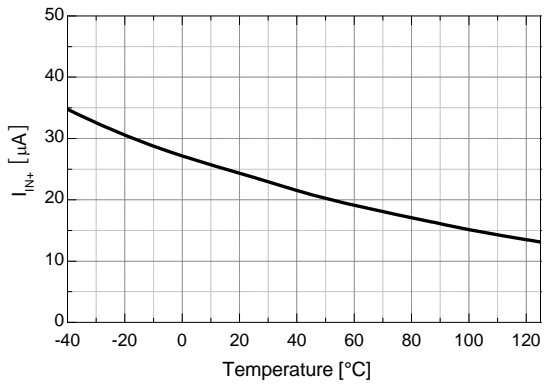

Figure 24. Logic Input High Bias Current vs. Temp.

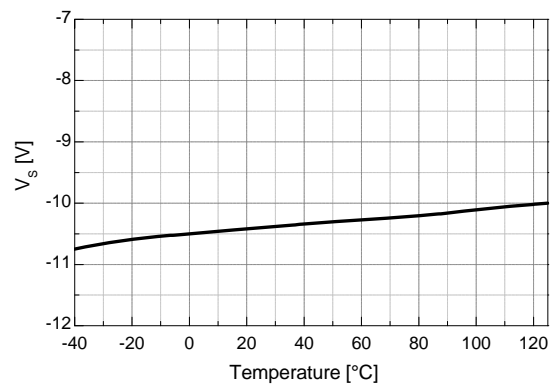

Figure 25. Allowable Negative V<sub>S</sub> Voltage vs. Temp.

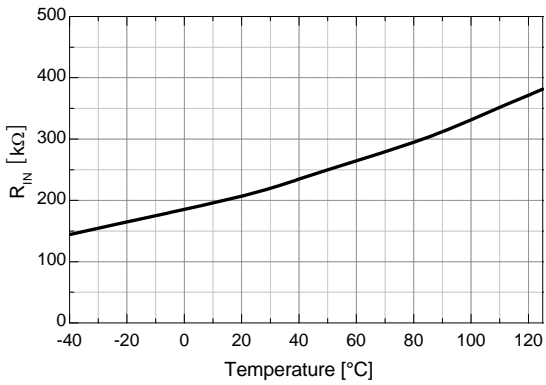

Figure 26. Input Pull-down Resistance vs. Temp.

## Application Information

### 1. Protection Function

#### 1.1 Under-Voltage Lockout (UVLO)

The high- and low-side drivers include under-voltage lockout (UVLO) protection circuitry for each channel that monitors the supply voltage ( $V_{DD}$ ) and bootstrap capacitor voltage ( $V_{BS1,2,3}$ ) independently. It can be designed to prevent malfunction when  $V_{DD}$  and  $V_{BS1,2,3}$  are lower than the specified threshold voltage. The UVLO hysteresis prevents chattering during power supply transitions.

#### 1.2 Shoot-Through Prevention Function

The FAN7888 has shoot-through prevention circuitry monitoring the high- and low-side control inputs. It can be designed to prevent outputs of high and low side from turning on at same time, as shown Figure 27 and 28.

### 2. Operational Notes

The FAN7888 is a three half-bridge gate driver with internal, typical 270 ns dead-time for the three-phase brushless DC (BLDC) motor drive system, as shown in Figure 1.

Figure 29 shows a switching sequence of 120° electrical commutation for a three-phase BLDC motor drive system. The waveforms are idealized: they assumed that the generated back EMF waveforms are trapezoidal with flat tops of sufficient width to produce constant torque when the line currents are perfectly rectangular, 120° electrical degrees, with the switching sequence as shown in Figure 29. The operating waveforms of the wye-connection reveal that repeat every 60 electrical degrees, with each 60° segment being “commutated” to another phase, as shown in Figure 29.

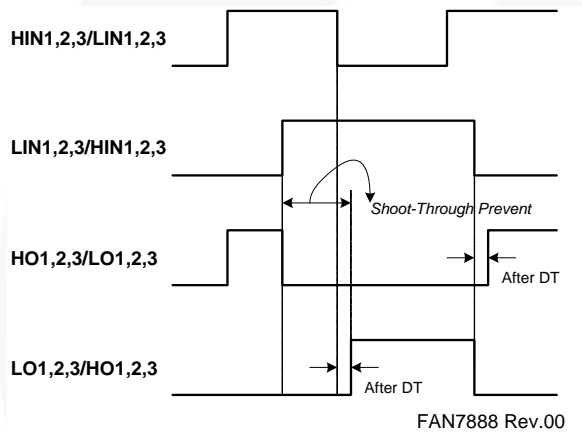

Figure 27. Waveforms for Shoot-Through Prevention

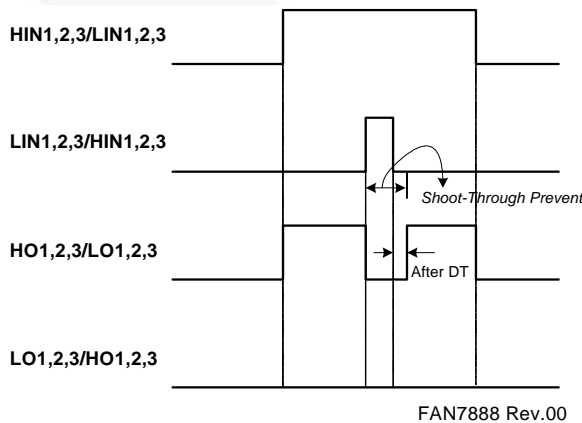

Figure 28. Waveforms for Shoot-Through Prevention

Application Information (Continued)

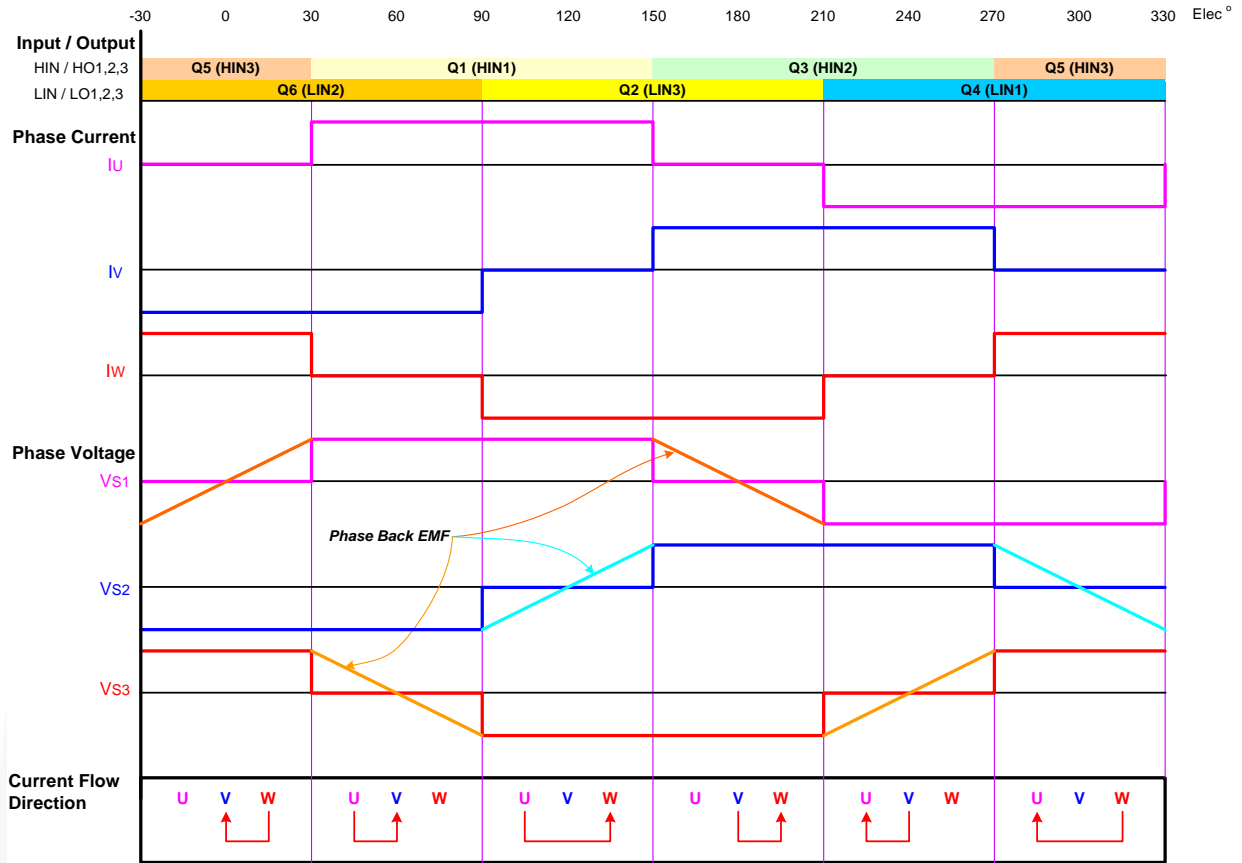

Figure 29. 120° Commutation Operation Waveforms for 3-Phase BLDC Motor Application

Switching Time Diagram

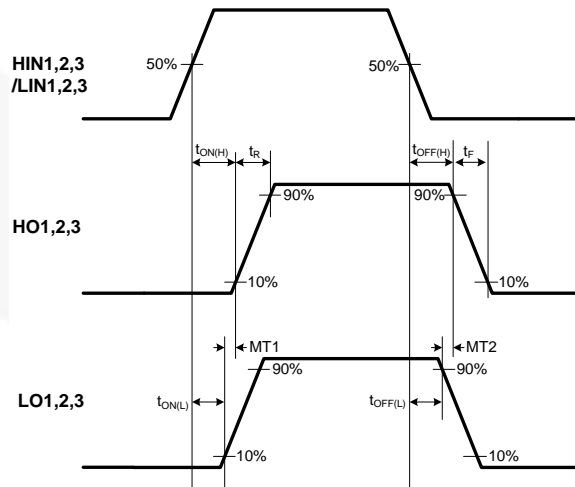
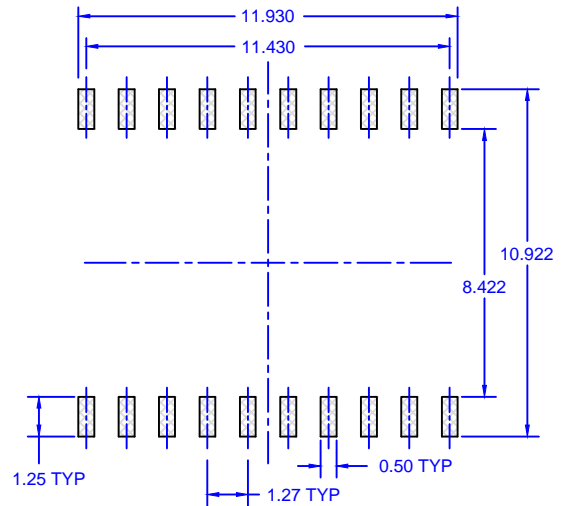
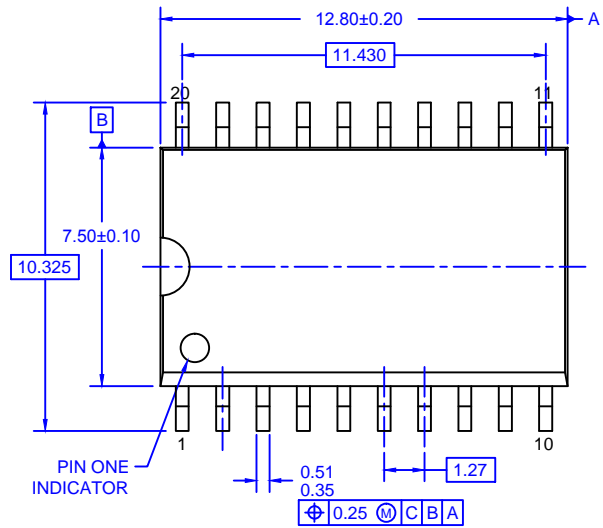
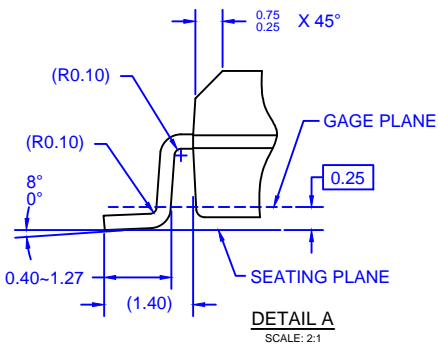
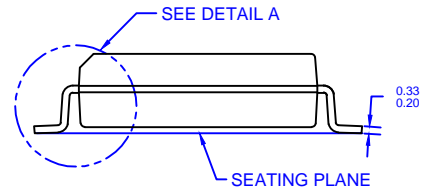
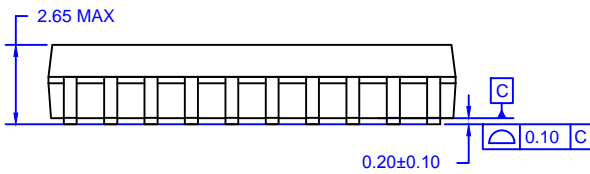

Figure 30. Switching Time Definition



LAND PATTERN RECOMMENDATION



PIN#1 IDENTIFICATION OPTIONS

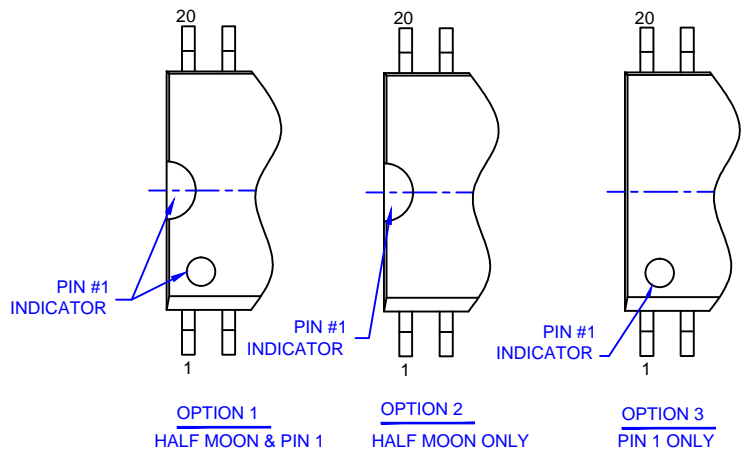

NOTES: UNLESS OTHERWISE SPECIFIED

- A) THIS PACKAGE CONFORMS TO JEDEC MS-013.
- B) ALL DIMENSIONS ARE IN MILLIMETERS.
- C) DIMENSIONS DO NOT INCLUDE MOLD FLASH OR BURRS.
- D) LANDPATTERN RECOMMENDATION IS FSC DESIGN
- E) FILENAME AND REVISION: M20Brev4

ON Semiconductor and  are trademarks of Semiconductor Components Industries, LLC dba ON Semiconductor or its subsidiaries in the United States and/or other countries. ON Semiconductor owns the rights to a number of patents, trademarks, copyrights, trade secrets, and other intellectual property. A listing of ON Semiconductor's product/patent coverage may be accessed at [www.onsemi.com/site/pdf/Patent-Marking.pdf](http://www.onsemi.com/site/pdf/Patent-Marking.pdf). ON Semiconductor reserves the right to make changes without further notice to any products herein. ON Semiconductor makes no warranty, representation or guarantee regarding the suitability of its products for any particular purpose, nor does ON Semiconductor assume any liability arising out of the application or use of any product or circuit, and specifically disclaims any and all liability, including without limitation special, consequential or incidental damages. Buyer is responsible for its products and applications using ON Semiconductor products, including compliance with all laws, regulations and safety requirements or standards, regardless of any support or applications information provided by ON Semiconductor. "Typical" parameters which may be provided in ON Semiconductor data sheets and/or specifications can and do vary in different applications and actual performance may vary over time. All operating parameters, including "Typicals" must be validated for each customer application by customer's technical experts. ON Semiconductor does not convey any license under its patent rights nor the rights of others. ON Semiconductor products are not designed, intended, or authorized for use as a critical component in life support systems or any FDA Class 3 medical devices or medical devices with a same or similar classification in a foreign jurisdiction or any devices intended for implantation in the human body. Should Buyer purchase or use ON Semiconductor products for any such unintended or unauthorized application, Buyer shall indemnify and hold ON Semiconductor and its officers, employees, subsidiaries, affiliates, and distributors harmless against all claims, costs, damages, and expenses, and reasonable attorney fees arising out of, directly or indirectly, any claim of personal injury or death associated with such unintended or unauthorized use, even if such claim alleges that ON Semiconductor was negligent regarding the design or manufacture of the part. ON Semiconductor is an Equal Opportunity/Affirmative Action Employer. This literature is subject to all applicable copyright laws and is not for resale in any manner.

## PUBLICATION ORDERING INFORMATION

### LITERATURE FULFILLMENT:

Literature Distribution Center for ON Semiconductor  
19521 E. 32nd Pkwy, Aurora, Colorado 80011 USA  
**Phone:** 303-675-2175 or 800-344-3860 Toll Free USA/Canada  
**Fax:** 303-675-2176 or 800-344-3867 Toll Free USA/Canada  
**Email:** [orderlit@onsemi.com](mailto:orderlit@onsemi.com)

**N. American Technical Support:** 800-282-9855 Toll Free  
USA/Canada  
**Europe, Middle East and Africa Technical Support:**  
Phone: 421 33 790 2910  
**Japan Customer Focus Center**  
Phone: 81-3-5817-1050

**ON Semiconductor Website:** [www.onsemi.com](http://www.onsemi.com)  
**Order Literature:** <http://www.onsemi.com/orderlit>  
For additional information, please contact your local  
Sales Representative

# Mouser Electronics

Authorized Distributor

Click to View Pricing, Inventory, Delivery & Lifecycle Information:

[ON Semiconductor:](#)

[FAN7888M](#) [FAN7888MX](#)



Компания «Океан Электроники» предлагает заключение долгосрочных отношений при поставках импортных электронных компонентов на взаимовыгодных условиях!

Наши преимущества:

- Поставка оригинальных импортных электронных компонентов напрямую с производств Америки, Европы и Азии, а так же с крупнейших складов мира;
- Широкая линейка поставок активных и пассивных импортных электронных компонентов (более 30 млн. наименований);
- Поставка сложных, дефицитных, либо снятых с производства позиций;
- Оперативные сроки поставки под заказ (от 5 рабочих дней);
- Экспресс доставка в любую точку России;
- Помощь Конструкторского Отдела и консультации квалифицированных инженеров;
- Техническая поддержка проекта, помощь в подборе аналогов, поставка прототипов;
- Поставка электронных компонентов под контролем ВП;
- Система менеджмента качества сертифицирована по Международному стандарту ISO 9001;
- При необходимости вся продукция военного и аэрокосмического назначения проходит испытания и сертификацию в лаборатории (по согласованию с заказчиком);
- Поставка специализированных компонентов военного и аэрокосмического уровня качества (Xilinx, Altera, Analog Devices, Intersil, Interpoint, Microsemi, Actel, Aeroflex, Peregrine, VPT, Syfer, Eurofarad, Texas Instruments, MS Kennedy, Miteq, Cobham, E2V, MA-COM, Hittite, Mini-Circuits, General Dynamics и др.);

Компания «Океан Электроники» является официальным дистрибьютором и эксклюзивным представителем в России одного из крупнейших производителей разъемов военного и аэрокосмического назначения «**JONHON**», а так же официальным дистрибьютором и эксклюзивным представителем в России производителя высокотехнологичных и надежных решений для передачи СВЧ сигналов «**FORSTAR**».



## JONHON

«**JONHON**» (основан в 1970 г.)

Разъемы специального, военного и аэрокосмического назначения:

(Применяются в военной, авиационной, аэрокосмической, морской, железнодорожной, горно- и нефтедобывающей отраслях промышленности)

«**FORSTAR**» (основан в 1998 г.)

ВЧ соединители, коаксиальные кабели,  
кабельные сборки и микроволновые компоненты:

(Применяются в телекоммуникациях гражданского и специального назначения, в средствах связи, РЛС, а так же военной, авиационной и аэрокосмической отраслях промышленности).



Телефон: 8 (812) 309-75-97 (многоканальный)

Факс: 8 (812) 320-03-32

Электронная почта: [ocean@oceanchips.ru](mailto:ocean@oceanchips.ru)

Web: <http://oceanchips.ru/>

Адрес: 198099, г. Санкт-Петербург, ул. Калинина, д. 2, корп. 4, лит. А