

To our customers,

Old Company Name in Catalogs and Other Documents

On April 1st, 2010, NEC Electronics Corporation merged with Renesas Technology Corporation, and Renesas Electronics Corporation took over all the business of both companies. Therefore, although the old company name remains in this document, it is a valid Renesas Electronics document. We appreciate your understanding.

Renesas Electronics website: <http://www.renesas.com>

April 1st, 2010
Renesas Electronics Corporation

Issued by: Renesas Electronics Corporation (<http://www.renesas.com>)

Send any inquiries to <http://www.renesas.com/inquiry>.

Notice

1. All information included in this document is current as of the date this document is issued. Such information, however, is subject to change without any prior notice. Before purchasing or using any Renesas Electronics products listed herein, please confirm the latest product information with a Renesas Electronics sales office. Also, please pay regular and careful attention to additional and different information to be disclosed by Renesas Electronics such as that disclosed through our website.
2. Renesas Electronics does not assume any liability for infringement of patents, copyrights, or other intellectual property rights of third parties by or arising from the use of Renesas Electronics products or technical information described in this document. No license, express, implied or otherwise, is granted hereby under any patents, copyrights or other intellectual property rights of Renesas Electronics or others.
3. You should not alter, modify, copy, or otherwise misappropriate any Renesas Electronics product, whether in whole or in part.
4. Descriptions of circuits, software and other related information in this document are provided only to illustrate the operation of semiconductor products and application examples. You are fully responsible for the incorporation of these circuits, software, and information in the design of your equipment. Renesas Electronics assumes no responsibility for any losses incurred by you or third parties arising from the use of these circuits, software, or information.
5. When exporting the products or technology described in this document, you should comply with the applicable export control laws and regulations and follow the procedures required by such laws and regulations. You should not use Renesas Electronics products or the technology described in this document for any purpose relating to military applications or use by the military, including but not limited to the development of weapons of mass destruction. Renesas Electronics products and technology may not be used for or incorporated into any products or systems whose manufacture, use, or sale is prohibited under any applicable domestic or foreign laws or regulations.
6. Renesas Electronics has used reasonable care in preparing the information included in this document, but Renesas Electronics does not warrant that such information is error free. Renesas Electronics assumes no liability whatsoever for any damages incurred by you resulting from errors in or omissions from the information included herein.
7. Renesas Electronics products are classified according to the following three quality grades: “Standard”, “High Quality”, and “Specific”. The recommended applications for each Renesas Electronics product depends on the product’s quality grade, as indicated below. You must check the quality grade of each Renesas Electronics product before using it in a particular application. You may not use any Renesas Electronics product for any application categorized as “Specific” without the prior written consent of Renesas Electronics. Further, you may not use any Renesas Electronics product for any application for which it is not intended without the prior written consent of Renesas Electronics. Renesas Electronics shall not be in any way liable for any damages or losses incurred by you or third parties arising from the use of any Renesas Electronics product for an application categorized as “Specific” or for which the product is not intended where you have failed to obtain the prior written consent of Renesas Electronics. The quality grade of each Renesas Electronics product is “Standard” unless otherwise expressly specified in a Renesas Electronics data sheets or data books, etc.
 - “Standard”: Computers; office equipment; communications equipment; test and measurement equipment; audio and visual equipment; home electronic appliances; machine tools; personal electronic equipment; and industrial robots.
 - “High Quality”: Transportation equipment (automobiles, trains, ships, etc.); traffic control systems; anti-disaster systems; anti-crime systems; safety equipment; and medical equipment not specifically designed for life support.
 - “Specific”: Aircraft; aerospace equipment; submersible repeaters; nuclear reactor control systems; medical equipment or systems for life support (e.g. artificial life support devices or systems), surgical implantations, or healthcare intervention (e.g. excision, etc.), and any other applications or purposes that pose a direct threat to human life.
8. You should use the Renesas Electronics products described in this document within the range specified by Renesas Electronics, especially with respect to the maximum rating, operating supply voltage range, movement power voltage range, heat radiation characteristics, installation and other product characteristics. Renesas Electronics shall have no liability for malfunctions or damages arising out of the use of Renesas Electronics products beyond such specified ranges.
9. Although Renesas Electronics endeavors to improve the quality and reliability of its products, semiconductor products have specific characteristics such as the occurrence of failure at a certain rate and malfunctions under certain use conditions. Further, Renesas Electronics products are not subject to radiation resistance design. Please be sure to implement safety measures to guard them against the possibility of physical injury, and injury or damage caused by fire in the event of the failure of a Renesas Electronics product, such as safety design for hardware and software including but not limited to redundancy, fire control and malfunction prevention, appropriate treatment for aging degradation or any other appropriate measures. Because the evaluation of microcomputer software alone is very difficult, please evaluate the safety of the final products or system manufactured by you.
10. Please contact a Renesas Electronics sales office for details as to environmental matters such as the environmental compatibility of each Renesas Electronics product. Please use Renesas Electronics products in compliance with all applicable laws and regulations that regulate the inclusion or use of controlled substances, including without limitation, the EU RoHS Directive. Renesas Electronics assumes no liability for damages or losses occurring as a result of your noncompliance with applicable laws and regulations.
11. This document may not be reproduced or duplicated, in any form, in whole or in part, without prior written consent of Renesas Electronics.
12. Please contact a Renesas Electronics sales office if you have any questions regarding the information contained in this document or Renesas Electronics products, or if you have any other inquiries.

(Note 1) “Renesas Electronics” as used in this document means Renesas Electronics Corporation and also includes its majority-owned subsidiaries.

(Note 2) “Renesas Electronics product(s)” means any product developed or manufactured by or for Renesas Electronics.

1. Overview

This MCU is built using the high-performance silicon gate CMOS process using a R8C/Tiny Series CPU core and is packaged in a 32-pin plastic molded LQFP. This MCU operates using sophisticated instructions featuring a high level of instruction efficiency. With 1M bytes of address space, it is capable of executing instructions at high speed.

1.1 Applications

Electric household appliance, office equipment, housing equipment (sensor, security), general industrial equipment, audio, etc.

1.2 Performance Overview

Table 1.1. lists the performance outline of this MCU.

Table 1.1 Performance outline

Item		Performance
CPU	Number of basic instructions	89 instructions
	Minimum instruction execution time	50 ns ($f(X_{IN}) = 20 \text{ MHz}$, $V_{CC} = 3.0 \text{ to } 5.5 \text{ V}$) 100 ns ($f(X_{IN}) = 10 \text{ MHz}$, $V_{CC} = 2.7 \text{ to } 5.5 \text{ V}$)
	Operating mode	Single-chip
	Address space	1M bytes
	Memory capacity	See Table 1.2.
Peripheral function	Port	Input/Output: 22 (including LED drive port), Input: 2
	LED drive port	I/O port: 8
	Timer	Timer X: 8 bits x 1 channel, Timer Y: 8 bits x 1 channel, Timer Z: 8 bits x 1 channel (Each timer equipped with 8-bit prescaler) Timer C: 16 bits x 1 channel (Circuits of input capture and output compare)
	Serial Interface	•1 channel Clock synchronous, UART •1 channel UART
	A/D converter	10-bit A/D converter: 1 circuit, 12 channels
	Watchdog timer	15 bits x 1 (with prescaler)
	Interrupt	Internal: 11 factors, External: 5 factors, Software: 4 factors, Priority level: 7 levels
	Clock generation circuit	2 circuits •Main clock generation circuit (Equipped with a built-in feedback resistor) •On-chip oscillator (high speed, low speed) On High-speed on-chip oscillator the frequency adjustment function is usable.
	Oscillation stop detection function	Main clock oscillation stop detection function
	Voltage detection circuit	Included
	Power on reset circuit	Included
Electrical characteristics	Supply voltage	$V_{CC} = 3.0 \text{ to } 5.5 \text{ V}$ ($f(X_{IN}) = 20 \text{ MHz}$) $V_{CC} = 2.7 \text{ to } 5.5 \text{ V}$ ($f(X_{IN}) = 10 \text{ MHz}$)
	Power consumption	Typ. 9 mA ($V_{CC} = 5.0 \text{ V}$, ($f(X_{IN}) = 20 \text{ MHz}$) Typ. 5 mA ($V_{CC} = 3.0 \text{ V}$, ($f(X_{IN}) = 10 \text{ MHz}$) Typ. 35 μA ($V_{CC} = 3.0 \text{ V}$, Wait mode, Peripheral clock off) Typ. 0.7 μA ($V_{CC} = 3.0 \text{ V}$, Stop mode)
Flash memory	Program/erase supply voltage	$V_{CC} = 2.7 \text{ to } 5.5 \text{ V}$
	Program/erase endurance	100 times
Operating ambient temperature		-20 to 85 °C -40 to 85 °C (D-version)
Package		32-pin plastic mold LQFP

1.3 Block Diagram

Figure 1.1 shows this MCU block diagram.

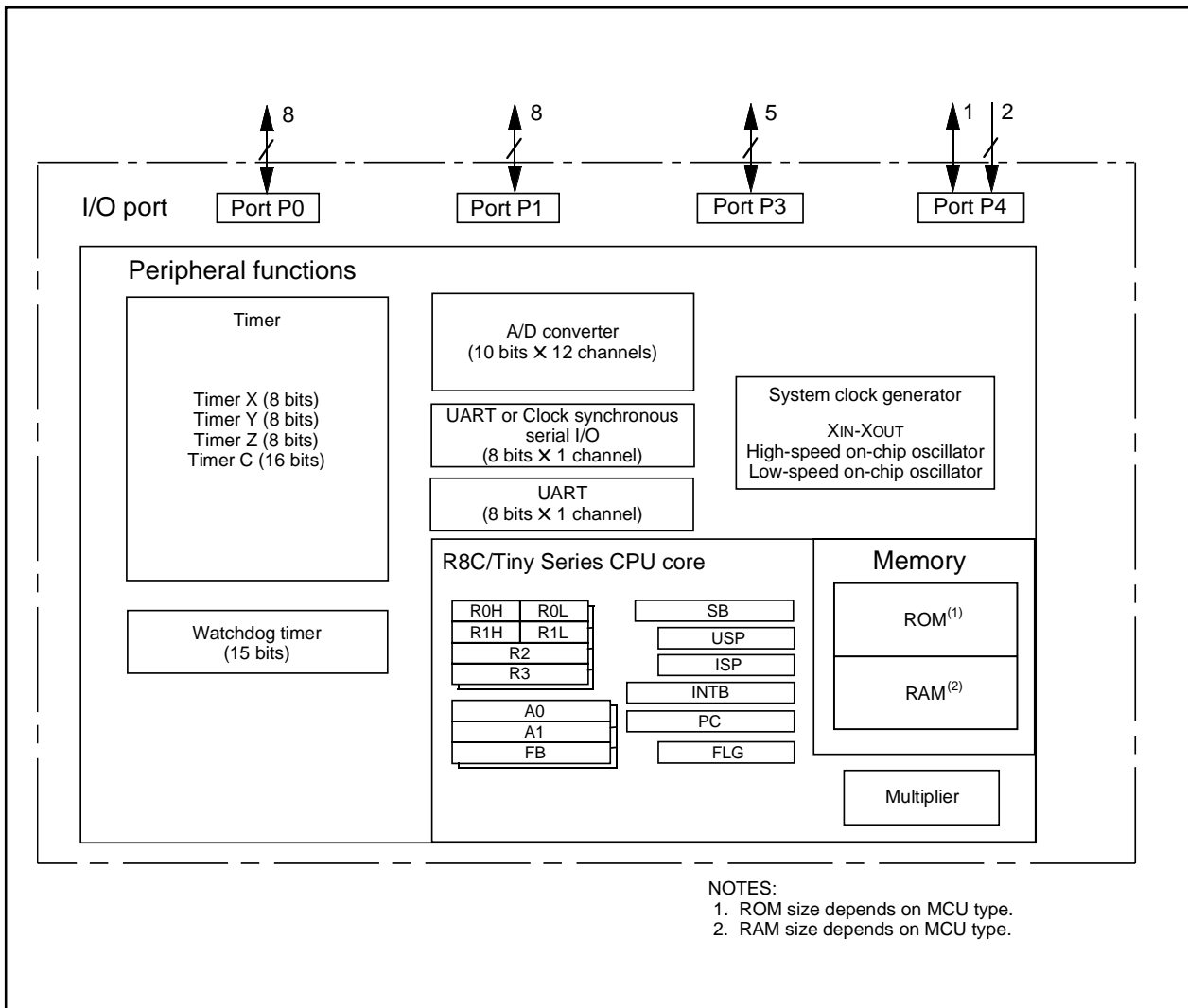

Figure 1.1 Block Diagram

1.4 Product Information

Table 1.2 lists the product information.

Table 1.2 Product Information

As of January 2006

Type No.	ROM capacity	RAM capacity	Package type	Remarks
R5F21112FP	8K bytes	512 bytes	PLQP0032GB-A	Flash memory version
R5F21113FP	12K bytes	768 bytes	PLQP0032GB-A	
R5F21114FP	16K bytes	1K bytes	PLQP0032GB-A	
R5F21112DFP	8K bytes	512 bytes	PLQP0032GB-A	D version
R5F21113DFP	12K bytes	768 bytes	PLQP0032GB-A	
R5F21114DFP	16K bytes	1K bytes	PLQP0032GB-A	

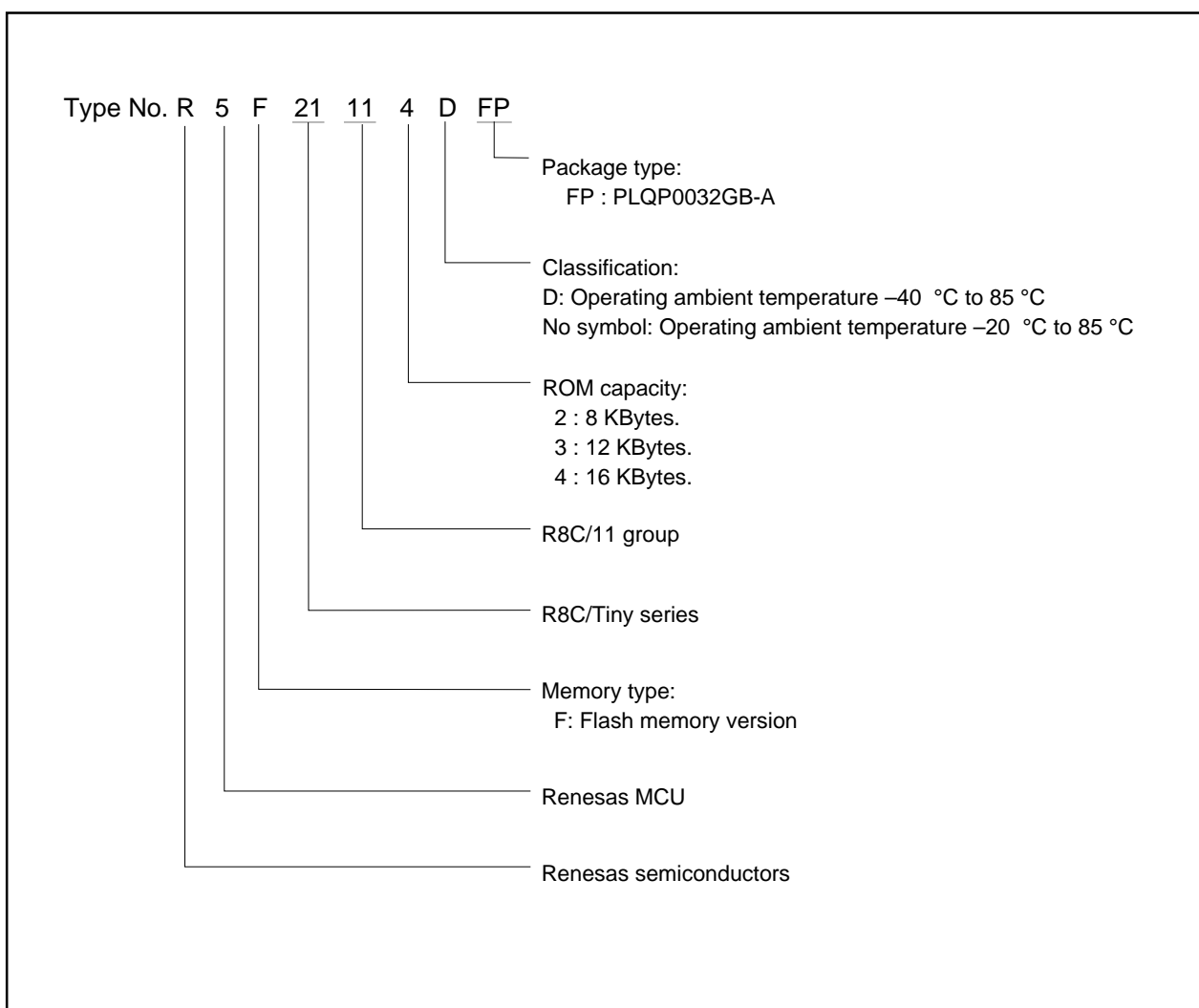

Figure 1.2 Type No., Memory Size, and Package

1.5 Pin Assignments

Figure 1.3 shows the pin configuration (top view).

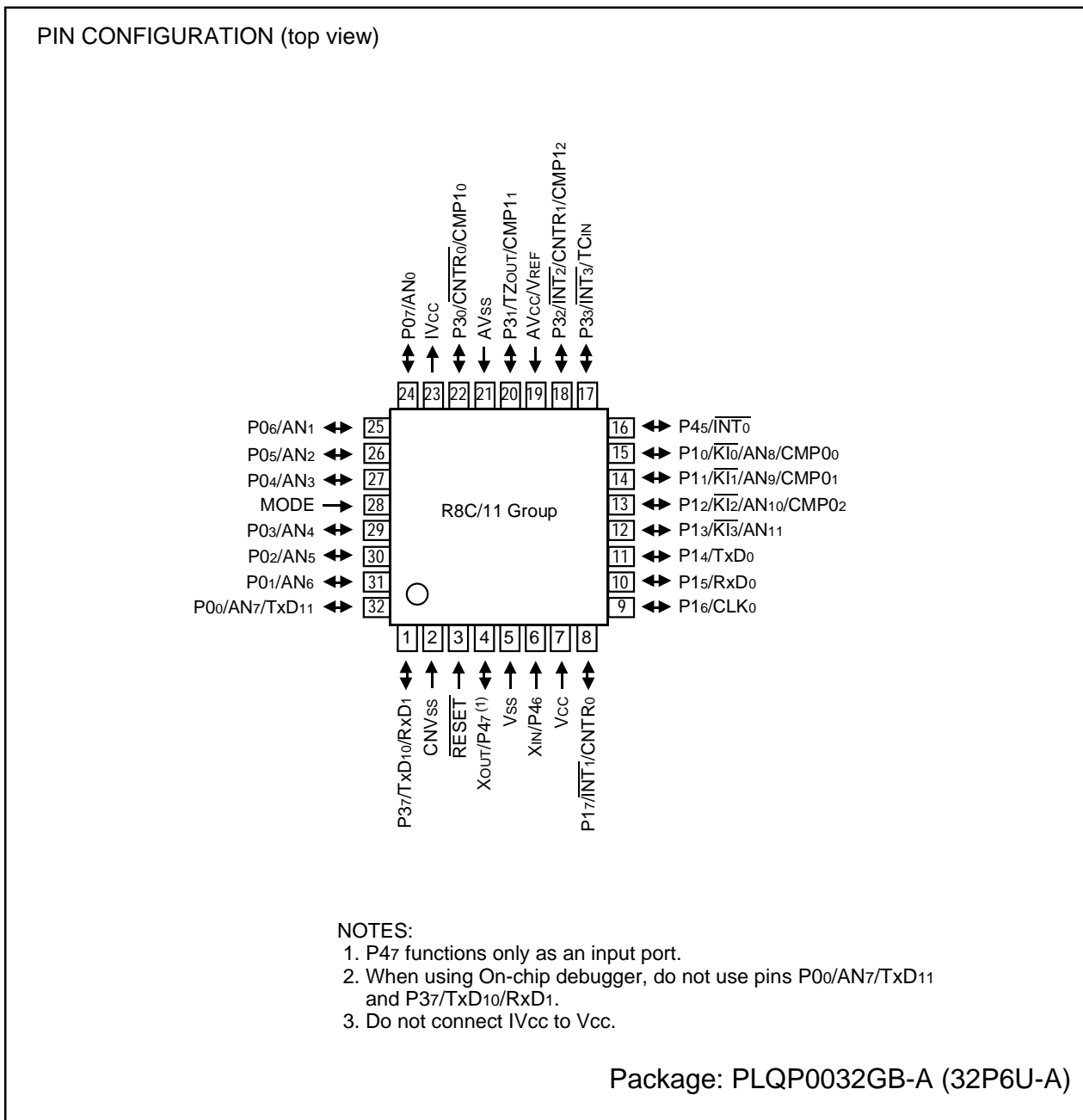

Figure 1.3 Pin Assignments (Top View)

1.6 Pin Description

Table 1.3 shows the pin description

Table 1.3 Pin description

Signal name	Pin name	I/O type	Function
Power supply input	Vcc, Vss	I	Apply 2.7 V to 5.5 V to the Vcc pin. Apply 0 V to the Vss pin.
IVcc	IVcc	O	This pin is to stabilize internal power supply. Connect this pin to Vss via a capacitor (0.1 μ F). Do not connect to Vcc.
Analog power supply input	AVcc, AVss	I	Power supply input pins for A/D converter. Connect the AVcc pin to Vcc. Connect the AVss pin to Vss. Connect a capacitor between pins AVcc and AVss.
Reset input	RESET	I	Input "L" on this pin resets the MCU.
CNVss	CNVss	I	Connect this pin to Vss via a resistor.
MODE	MODE	I	Connect this pin to Vcc via a resistor.
Main clock input	XIN	I	These pins are provided for the main clock generating circuit I/O. Connect a ceramic resonator or a crystal oscillator between the XIN and XOUT pins. To use an externally derived clock, input it to the XIN pin and leave the XOUT pin open.
Main clock output	XOUT	O	
INT interrupt input	INT $\bar{0}$ to INT $\bar{3}$	I	INT interrupt input pins.
Key input interrupt	KI $\bar{0}$ to KI $\bar{3}$	I	Key input interrupt pins.
Timer X	CNTR $\bar{0}$	I/O	Timer X I/O pin
	CNTR $\bar{0}$	O	Timer X output pin
Timer Y	CNTR $\bar{1}$	I/O	Timer Y I/O pin
Timer Z	TZOUT	O	Timer Z output pin
Timer C	TCIN	I	Timer C input pin
	CMP $\bar{0}$ to CMP $\bar{0}$ ₂ , CMP $\bar{1}$ ₀ to CMP $\bar{1}$ ₂	O	Timer C output pins
Serial interface	CLK $\bar{0}$	I/O	Transfer clock I/O pin.
	RxD $\bar{0}$, RxD $\bar{1}$	I	Serial data input pins.
	TxD $\bar{0}$, TxD $\bar{1}$ ₀ , TxD $\bar{1}$ ₁	O	Serial data output pins.
Reference voltage input	VREF	I	Reference voltage input pin for A/D converter. Connect the VREF pin to Vcc.
A/D converter	AN $\bar{0}$ to AN $\bar{1}$ ₁	I	Analog input pins for A/D converter
I/O port	P $\bar{0}$ to P $\bar{7}$, P $\bar{1}$ ₀ to P $\bar{1}$ ₇ , P $\bar{3}$ ₀ to P $\bar{3}$ ₃ , P $\bar{3}$ ₇ , P $\bar{4}$ ₅	I/O	These are 8-bit CMOS I/O ports. Each port has an I/O select direction register, allowing each pin in that port to be directed for input or output individually. Any port set to input can select whether to use a pull-up resistor or not by program. P $\bar{1}$ ₀ to P $\bar{1}$ ₇ also function as LED drive ports.
Input port	P $\bar{4}$ ₆ , P $\bar{4}$ ₇	I	Port for input-only

2. Central Processing Unit (CPU)

Figure 2.1 shows the CPU registers. The CPU has 13 registers. Of these, R0, R1, R2, R3, A0, A1 and FB comprise a register bank. Two sets of register banks are provided.

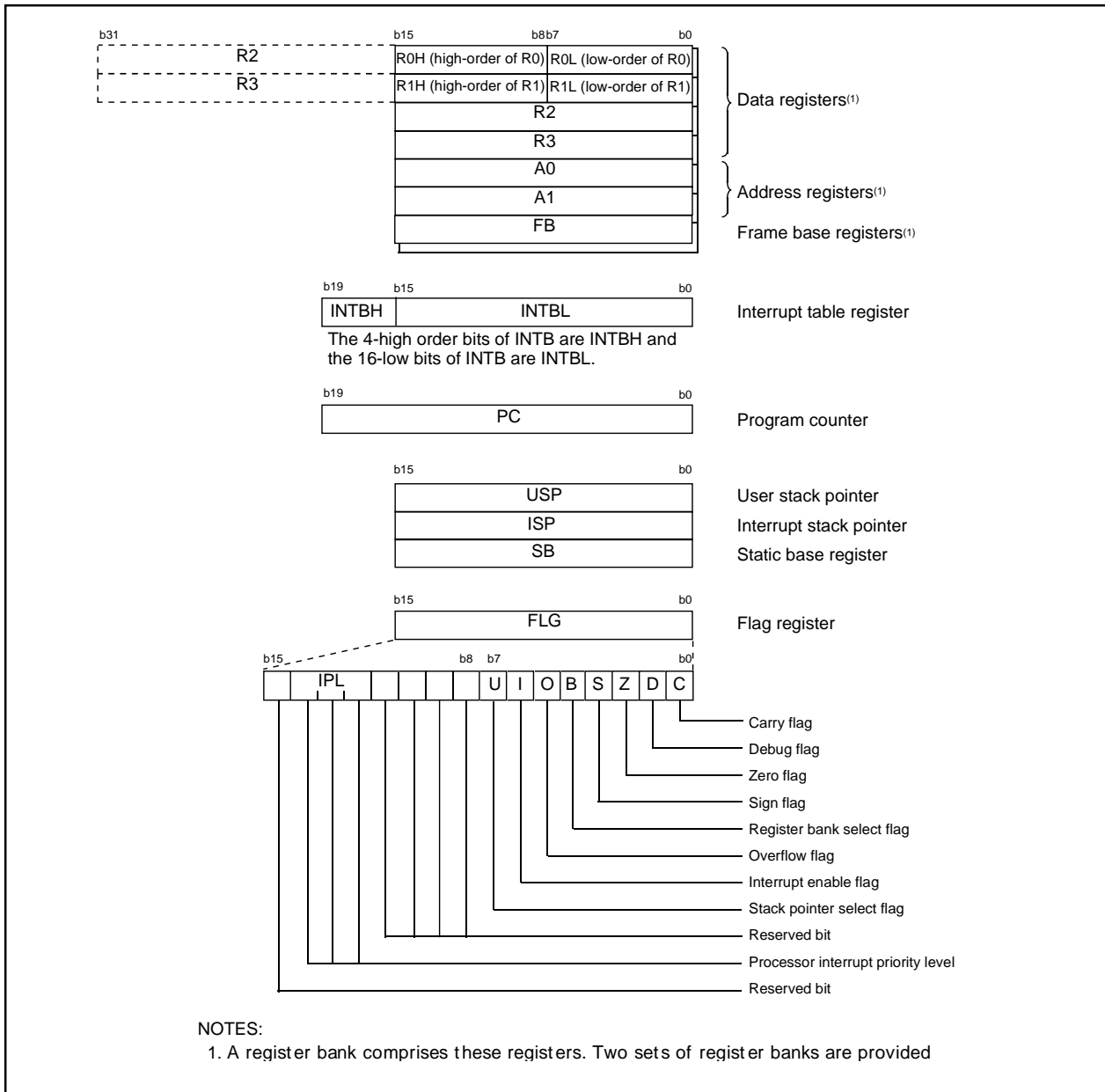

Figure 2.1 CPU Register

2.1 Data Registers (R0, R1, R2 and R3)

R0 is a 16-bit register for transfer, arithmetic and logic operations. The same applies to R1 to R3. The R0 can be split into high-order bit (R0H) and low-order bit (R0L) to be used separately as 8-bit data registers. The same applies to R1H and R1L as R0H and R0L. R2 can be combined with R0 to be used as a 32-bit data register (R2R0). The same applies to R3R1 as R2R0.

2.2 Address Registers (A0 and A1)

A0 is a 16-bit register for address register indirect addressing and address register relative addressing. They also are used for transfer, arithmetic and logic operations. The same applies to A1 as A0. A0 can be combined with A1 to be used as a 32-bit address register (A1A0).

2.3 Frame Base Register (FB)

FB is a 16-bit register for FB relative addressing.

2.4 Interrupt Table Register (INTB)

INTB is a 20-bit register indicates the start address of an interrupt vector table.

2.5 Program Counter (PC)

PC, 20 bits wide, indicates the address of an instruction to be executed.

2.6 User Stack Pointer (USP) and Interrupt Stack Pointer (ISP)

The stack pointer (SP), USP and ISP, are 16 bits wide each.

The U flag of FLG is used to switch between USP and ISP.

2.7 Static Base Register (SB)

SB is a 16-bit register for SB relative addressing.

2.8 Flag Register (FLG)

FLG is a 11-bit register indicating the CPU state.

2.8.1 Carry Flag (C)

The C flag retains a carry, borrow, or shift-out bit that has occurred in the arithmetic logic unit.

2.8.2 Debug Flag (D)

The D flag is for debug only. Set to "0".

2.8.3 Zero Flag (Z)

The Z flag is set to "1" when an arithmetic operation resulted in 0; otherwise, "0".

2.8.4 Sign Flag (S)

The S flag is set to "1" when an arithmetic operation resulted in a negative value; otherwise, "0".

2.8.5 Register Bank Select Flag (B)

The register bank 0 is selected when the B flag is "0". The register bank 1 is selected when this flag is set to "1".

2.8.6 Overflow Flag (O)

The O flag is set to "1" when the operation resulted in an overflow; otherwise, "0".

2.8.7 Interrupt Enable Flag (I)

The I flag enables a maskable interrupt.

An interrupt is disabled when the I flag is set to "0", and are enabled when the I flag is set to "1". The I flag is set to "0" when an interrupt request is acknowledged.

2.8.8 Stack Pointer Select Flag (U)

ISP is selected when the U flag is set to "0", USP is selected when the U flag is set to "1".

The U flag is set to "0" when a hardware interrupt request is acknowledged or the INT instruction of software interrupt numbers 0 to 31 is executed.

2.8.9 Processor Interrupt Priority Level (IPL)

IPL, 3 bits wide, assigns processor interrupt priority levels from level 0 to level 7.

If a requested interrupt has greater priority than IPL, the interrupt is enabled.

2.8.10 Reserved Bit

When write to this bit, set to "0". When read, its content is indeterminate.

3. Memory

Figure 3.1 is a memory map of this MCU. This MCU provides 1-Mbyte address space from addresses 00000₁₆ to FFFFF₁₆.

The internal ROM is allocated lower addresses beginning with address 0FFFF₁₆. For example, a 16-Kbyte internal ROM is allocated addresses from 0C000₁₆ to 0FFFF₁₆.

The fixed interrupt vector table is allocated addresses 0FFDC₁₆ to 0FFFF₁₆. They store the starting address of each interrupt routine.

The internal RAM is allocated higher addresses beginning with address 00400₁₆. For example, a 1-Kbyte internal RAM is allocated addresses 00400₁₆ to 007FF₁₆. The internal RAM is used not only for storing data, but for calling subroutines and stacks when interrupt request is acknowledged.

Special function registers (SFR) are allocated addresses 00000₁₆ to 002FF₁₆. The peripheral function control registers are located them. All addresses, which have nothing allocated within the SFR, are reserved area and cannot be accessed by users.

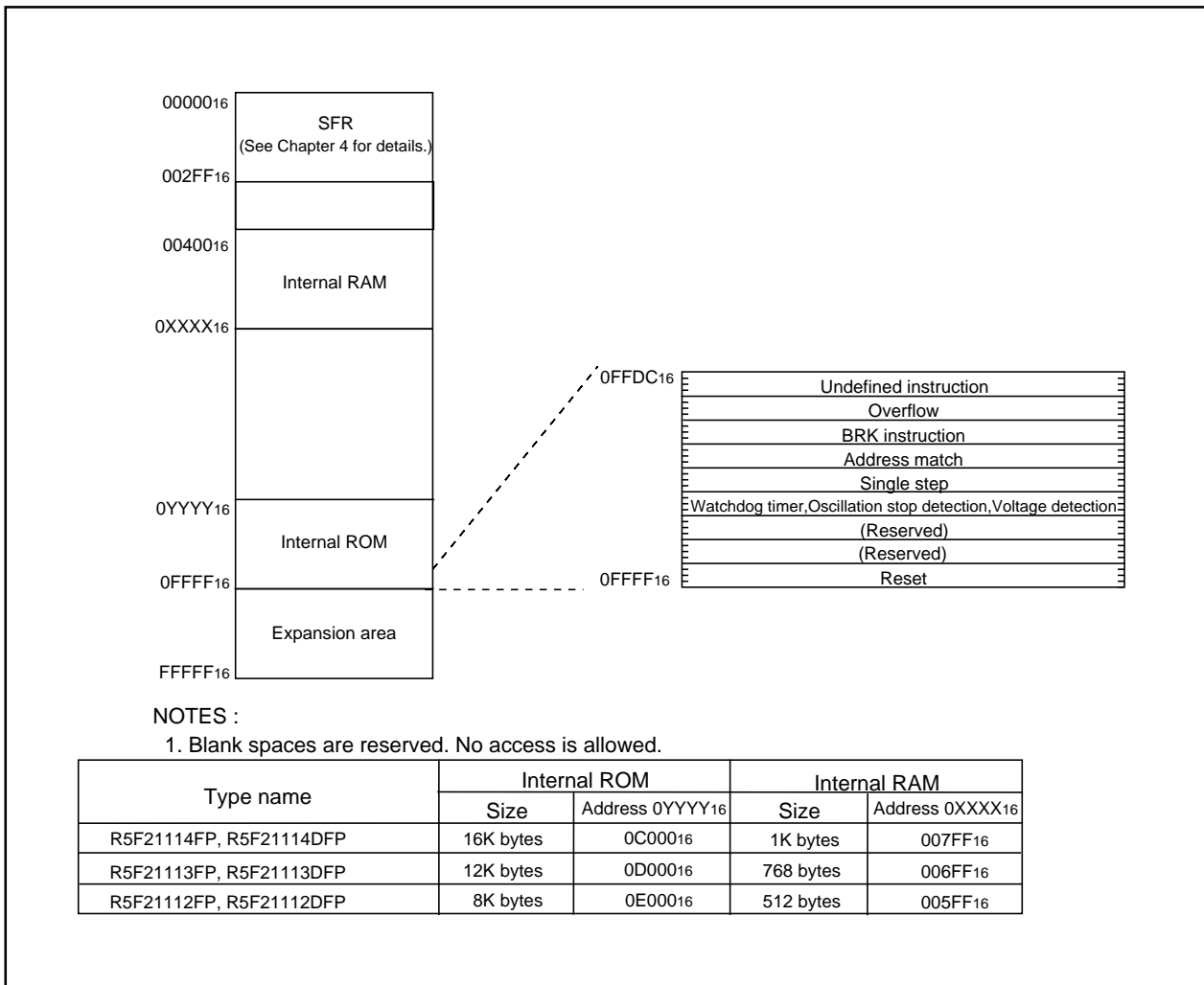

Figure 3.1 Memory Map

4. Special Function Register (SFR)

SFR(Special Function Register) is the control register of peripheral functions. Tables 4.1 to 4.4 list the SFR information

Table 4.1 SFR Information(1)(1)

Address	Register	Symbol	After reset
0000 ₁₆			
0001 ₁₆			
0002 ₁₆			
0003 ₁₆			
0004 ₁₆	Processor mode register 0	PM0	0016
0005 ₁₆	Processor mode register 1	PM1	0016
0006 ₁₆	System clock control register 0	CM0	011010002
0007 ₁₆	System clock control register 1	CM1	001000002
0008 ₁₆	High-speed on-chip oscillator control register 0	HR0	0016
0009 ₁₆	Address match interrupt enable register	AIER	XXXXXX002
000A ₁₆	Protect register	PRCR	00XXX0002
000B ₁₆	High-speed on-chip oscillator control register 1	HR1	4016
000C ₁₆	Oscillation stop detection register	OCD	000001002
000D ₁₆	Watchdog timer reset register	WDTR	XX16
000E ₁₆	Watchdog timer start register	WDTS	XX16
000F ₁₆	Watchdog timer control register	WDC	000111112
0010 ₁₆	Address match interrupt register 0	RMAD0	0016
0011 ₁₆			0016
0012 ₁₆			X016
0013 ₁₆			
0014 ₁₆	Address match interrupt register 1	RMAD1	0016
0015 ₁₆			0016
0016 ₁₆			X016
0017 ₁₆			
0018 ₁₆			
0019 ₁₆	Voltage detection register 1 ⁽²⁾	VCR1	000010002
001A ₁₆	Voltage detection register 2 ⁽²⁾	VCR2	0016 ⁽³⁾ 10000002 ⁽⁴⁾
001B ₁₆			
001C ₁₆			
001D ₁₆			
001E ₁₆	INT0 input filter select register	INT0F	XXXXX0002
001F ₁₆	Voltage detection interrupt register ⁽²⁾	D4INT	0016 ⁽³⁾ 010000012 ⁽⁴⁾
0020 ₁₆			
0021 ₁₆			
0022 ₁₆			
0023 ₁₆			
0024 ₁₆			
0025 ₁₆			
0026 ₁₆			
0027 ₁₆			
0028 ₁₆			
0029 ₁₆			
002A ₁₆			
002B ₁₆			
002C ₁₆			
002D ₁₆			
002E ₁₆			
002F ₁₆			
0030 ₁₆			
0031 ₁₆			
0032 ₁₆			
0033 ₁₆			
0034 ₁₆			
0035 ₁₆			
0036 ₁₆			
0037 ₁₆			
0038 ₁₆			
0039 ₁₆			
003A ₁₆			
003B ₁₆			
003C ₁₆			
003D ₁₆			
003E ₁₆			
003F ₁₆			

X : Undefined

NOTES:

- Blank spaces are reserved. No access is allowed.
- Software reset or the watchdog timer reset does not affect this register.
- Owing to Reset input.
- In the case of RESET pin = H retaining.

Table 4.2 SFR Information(2)⁽¹⁾

Address	Register	Symbol	After reset
0040 ₁₆			
0041 ₁₆			
0042 ₁₆			
0043 ₁₆			
0044 ₁₆			
0045 ₁₆			
0046 ₁₆			
0047 ₁₆			
0048 ₁₆			
0049 ₁₆			
004A ₁₆			
004B ₁₆			
004C ₁₆			
004D ₁₆	Key input interrupt control register	KUPIC	XXXXX0002
004E ₁₆	AD conversion interrupt control register	ADIC	XXXXX0002
004F ₁₆			
0050 ₁₆	Compare 1 interrupt control register	CMP1IC	XXXXX0002
0051 ₁₆	UART0 transmit interrupt control register	S0TIC	XXXXX0002
0052 ₁₆	UART0 receive interrupt control register	S0RIC	XXXXX0002
0053 ₁₆	UART1 transmit interrupt control register	S1TIC	XXXXX0002
0054 ₁₆	UART1 receive interrupt control register	S1RIC	XXXXX0002
0055 ₁₆	INT2 interrupt control register	INT2IC	XXXXX0002
0056 ₁₆	Timer X interrupt control register	TXIC	XXXXX0002
0057 ₁₆	Timer Y interrupt control register	TYIC	XXXXX0002
0058 ₁₆	Timer Z interrupt control register	TZIC	XXXXX0002
0059 ₁₆	INT1 interrupt control register	INT1IC	XXXXX0002
005A ₁₆	INT3 interrupt control register	INT3IC	XXXXX0002
005B ₁₆	Timer C interrupt control register	TCIC	XXXXX0002
005C ₁₆	Compare 0 interrupt control register	CMP0IC	XXXXX0002
005D ₁₆	INT0 interrupt control register	INT0IC	XX00X0002
005E ₁₆			
005F ₁₆			
0060 ₁₆			
0061 ₁₆			
0062 ₁₆			
0063 ₁₆			
0064 ₁₆			
0065 ₁₆			
0066 ₁₆			
0067 ₁₆			
0068 ₁₆			
0069 ₁₆			
006A ₁₆			
006B ₁₆			
006C ₁₆			
006D ₁₆			
006E ₁₆			
006F ₁₆			
0070 ₁₆			
0071 ₁₆			
0072 ₁₆			
0073 ₁₆			
0074 ₁₆			
0075 ₁₆			
0076 ₁₆			
0077 ₁₆			
0078 ₁₆			
0079 ₁₆			
007A ₁₆			
007B ₁₆			
007C ₁₆			
007D ₁₆			
007E ₁₆			
007F ₁₆			

X : Undefined

NOTES:

- Blank spaces are reserved. No access is allowed.

Table 4.3 SFR Information(3)(1)

Address	Register	Symbol	After reset
0080 ₁₆	Timer Y, Z mode register	TYZMR	0016
0081 ₁₆	Prescaler Y register	PREY	FF16
0082 ₁₆	Timer Y secondary register	TYSC	FF16
0083 ₁₆	Timer Y primary register	TYPR	FF16
0084 ₁₆	Timer Y, Z waveform output control register	PUM	0016
0085 ₁₆	Prescaler Z register	PREZ	FF16
0086 ₁₆	Timer Z secondary register	TZSC	FF16
0087 ₁₆	Timer Z primary register	TZPR	FF16
0088 ₁₆			
0089 ₁₆			
008A ₁₆	Timer Y, Z output control register	TYZOC	0016
008B ₁₆	Timer X mode register	TXMR	0016
008C ₁₆	Prescaler X register	PREX	FF16
008D ₁₆	Timer X register	TX	FF16
008E ₁₆	Timer count source set register	TCSS	0016
008F ₁₆			
0090 ₁₆	Timer C register	TC	0016
0091 ₁₆			0016
0092 ₁₆			
0093 ₁₆			
0094 ₁₆			
0095 ₁₆			
0096 ₁₆	External input enable register	INTEN	0016
0097 ₁₆			
0098 ₁₆	Key input enable register	KIEN	0016
0099 ₁₆			
009A ₁₆	Timer C control register 0	TCC0	0016
009B ₁₆	Timer C control register 1	TCC1	0016
009C ₁₆	Capture, compare 0 register	TM0	0016
009D ₁₆			0016 ⁽²⁾
009E ₁₆	Compare 1 register	TM1	FF16
009F ₁₆			FF16
00A0 ₁₆	UART0 transmit/receive mode register	U0MR	0016
00A1 ₁₆	UART0 bit rate register	U0BRG	XX16
00A2 ₁₆	UART0 transmit buffer register	U0TB	XX16
00A3 ₁₆			XX16
00A4 ₁₆	UART0 transmit/receive control register 0	U0C0	000010002
00A5 ₁₆	UART0 transmit/receive control register 1	U0C1	000000102
00A6 ₁₆	UART0 receive buffer register	U0RB	XX16
00A7 ₁₆			XX16
00A8 ₁₆	UART1 transmit/receive mode register	U1MR	0016
00A9 ₁₆	UART1 bit rate register	U1BRG	XX16
00AA ₁₆	UART1 transmit buffer register	U1TB	XX16
00AB ₁₆			XX16
00AC ₁₆	UART1 transmit/receive control register 0	U1C0	000010002
00AD ₁₆	UART1 transmit/receive control register 1	U1C1	000000102
00AE ₁₆	UART1 receive buffer register	U1RB	XX16
00AF ₁₆			XX16
00B0 ₁₆	UART transmit/receive control register 2	UCON	0016
00B1 ₁₆			
00B2 ₁₆			
00B3 ₁₆			
00B4 ₁₆			
00B5 ₁₆			
00B6 ₁₆			
00B7 ₁₆			
00B8 ₁₆			
00B9 ₁₆			
00BA ₁₆			
00BB ₁₆			
00BC ₁₆			
00BD ₁₆			
00BE ₁₆			
00BF ₁₆			

X : Undefined

NOTES:

- Blank spaces are reserved. No access is allowed.
- When output compare mode (the TCC13 bit in the TCC1 register = 1) is selected, the value after reset is set to "FFFF16".

Table 4.4 SFR Information(4)(1)

Address	Register	Symbol	After reset
00C0 ₁₆	AD register	AD	XX ₁₆
00C1 ₁₆			XX ₁₆
00C2 ₁₆			
00C3 ₁₆			
00C4 ₁₆			
00C5 ₁₆			
00C6 ₁₆			
00C7 ₁₆			
00C8 ₁₆			
00C9 ₁₆			
00CA ₁₆			
00CB ₁₆			
00CC ₁₆			
00CD ₁₆			
00CE ₁₆			
00CF ₁₆			
00D0 ₁₆			
00D1 ₁₆			
00D2 ₁₆			
00D3 ₁₆			
00D4 ₁₆	AD control register 2	ADCON2	00 ₁₆
00D5 ₁₆			
00D6 ₁₆	AD control register 0	ADCON0	00000XX ₂
00D7 ₁₆	AD control register 1	ADCON1	00 ₁₆
00D8 ₁₆			
00D9 ₁₆			
00DA ₁₆			
00DB ₁₆			
00DC ₁₆			
00DD ₁₆			
00DE ₁₆			
00DF ₁₆			
00E0 ₁₆	Port P0 register	P0	XX ₁₆
00E1 ₁₆	Port P1 register	P1	XX ₁₆
00E2 ₁₆	Port P0 direction register	PD0	00 ₁₆
00E3 ₁₆	Port P1 direction register	PD1	00 ₁₆
00E4 ₁₆			
00E5 ₁₆	Port P3 register	P3	XX ₁₆
00E6 ₁₆			
00E7 ₁₆	Port P3 direction register	PD3	00 ₁₆
00E8 ₁₆	Port P4 register	P4	XX ₁₆
00E9 ₁₆			
00EA ₁₆	Port P4 direction register	PD4	00 ₁₆
00EB ₁₆			
00EC ₁₆			
00ED ₁₆			
00EE ₁₆			
00EF ₁₆			
00F0 ₁₆			
00F1 ₁₆			
00F2 ₁₆			
00F3 ₁₆			
00F4 ₁₆			
00F5 ₁₆			
00F6 ₁₆			
00F7 ₁₆			
00F8 ₁₆			
00F9 ₁₆			
03FA ₁₆			
00FB ₁₆			
00FC ₁₆	Pull-up control register 0	PUR0	00XX0000 ₂
00FD ₁₆	Pull-up control register 1	PUR1	XXXXXX0X ₂
00FE ₁₆	Port P1 drive capacity control register	DRR	00 ₁₆
00FF ₁₆	Timer C output control register	TCOUT	00 ₁₆
~ ~ ~			
01B3 ₁₆	Flash memory control register 4	FMR4	01000000 ₂
01B4 ₁₆			
01B5 ₁₆	Flash memory control register 1	FMR1	0100XX0X ₂
01B6 ₁₆			
01B7 ₁₆	Flash memory control register 0	FMR0	00000001 ₂

X : Undefined

NOTES:

1. Blank columns, 0100₁₆ to 01B2₁₆ and 01B8₁₆ to 02FF₁₆ are all reserved. No access is allowed.

5. Electrical Characteristics

Table 5.1 Absolute Maximum Ratings

Symbol	Parameter	Condition	Rated value	Unit
V _{CC}	Supply voltage	V _{CC} =AV _{CC}	-0.3 to 6.5	V
AV _{CC}	Analog supply voltage	V _{CC} =AV _{CC}	-0.3 to 6.5	V
V _I	Input voltage		-0.3 to V _{CC} +0.3	V
V _O	Output voltage		-0.3 to V _{CC} +0.3	V
P _d	Power dissipation	T _{opr} =25 °C	300	mW
T _{opr}	Operating ambient temperature		-20 to 85 / -40 to 85 (D version)	°C
T _{stg}	Storage temperature		-65 to 150	°C

Table 5.2 Recommended Operating Conditions

Symbol	Parameter	Conditions	Standard			Unit	
			Min.	Typ.	Max.		
V _{CC}	Supply voltage		2.7	—	5.5	V	
AV _{CC}	Analog supply voltage		—	V _{CC} (³)	—	V	
V _{SS}	Supply voltage		—	0	—	V	
AV _{SS}	Analog supply voltage		—	0	—	V	
V _{IH}	"H" input voltage		0.8V _{CC}	—	V _{CC}	V	
V _{IL}	"L" input voltage		0	—	0.2V _{CC}	V	
I _{OH} (sum)	"H" peak all output currents	Sum of all pins' IOH (peak)	—	—	-60.0	mA	
I _{OH} (peak)	"H" peak output current		—	—	-10.0	mA	
I _{OH} (avg)	"H" average output current		—	—	-5.0	mA	
I _{OL} (sum)	"L" peak all output currents	Sum of all pins' IOL (peak)	—	—	60	mA	
I _{OL} (peak)	"L" peak output current	Except P1 ₀ to P1 ₇	—	—	10	mA	
		P1 ₀ to P1 ₇	Drive capacity HIGH	—	—	30	mA
			Drive capacity LOW	—	—	10	mA
I _{OL} (avg)	"L" average output current	Except P1 ₀ to P1 ₇	—	—	5	mA	
		P1 ₀ to P1 ₇	Drive capacity HIGH	—	—	15	mA
			Drive capacity LOW	—	—	5	mA
f (XIN)	Main clock input oscillation frequency	3.0V ≤ V _{CC} ≤ 5.5V	0	—	20	MHz	
		2.7V ≤ V _{CC} < 3.0V	0	—	10	MHz	

NOTES:

1. V_{CC} = AV_{CC} = 2.7 to 5.5V at T_{opr} = -20 to 85 °C / -40 to 85 °C, unless otherwise specified.
2. The typical values when average output current is 100ms.
3. Hold V_{CC}=AV_{CC}.

Table 5.3 A/D Conversion Characteristics

Symbol	Parameter		Measuring condition	Standard			Unit
				Min.	Typ.	Max.	
—	Resolution		$V_{ref} = V_{CC}$	—	—	10	Bit
—	Absolute accuracy	10 bit mode	$\phi_{AD} = 10 \text{ MHz}$, $V_{ref} = V_{CC} = 5.0 \text{ V}$	—	—	± 3	LSB
		8 bit mode	$\phi_{AD} = 10 \text{ MHz}$, $V_{ref} = V_{CC} = 5.0 \text{ V}$	—	—	± 2	LSB
		10 bit mode	$\phi_{AD} = 10 \text{ MHz}$, $V_{ref} = V_{CC} = 3.3 \text{ V}^{(3)}$	—	—	± 5	LSB
		8 bit mode	$\phi_{AD} = 10 \text{ MHz}$, $V_{ref} = V_{CC} = 3.3 \text{ V}^{(3)}$	—	—	± 2	LSB
R_{LADDER}	Ladder resistance		$V_{REF} = V_{CC}$	10	—	40	$k\Omega$
t_{CONV}	Conversion time	10 bit mode	$\phi_{AD} = 10 \text{ MHz}$, $V_{ref} = V_{CC} = 5.0 \text{ V}$	3.3	—	—	μs
		8 bit mode	$\phi_{AD} = 10 \text{ MHz}$, $V_{ref} = V_{CC} = 5.0 \text{ V}$	2.8	—	—	μs
V_{REF}	Reference voltage			—	$V_{CC}^{(4)}$	—	V
V_{IA}	Analog input voltage			0	—	V_{ref}	V
—	A/D operating clock frequency ⁽²⁾	Without sample & hold		0.25	—	10	MHz
		With sample & hold		1.0	—	10	MHz

NOTES:

1. $V_{CC} = AV_{CC} = 2.7$ to 5.5 V at $T_{opr} = -20$ to $85 \text{ }^\circ\text{C}$ / -40 to $85 \text{ }^\circ\text{C}$, unless otherwise specified.
2. If f_{AD} exceeds 10 MHz more, divide the f_{AD} and hold A/D operating clock frequency (ϕ_{AD}) 10 MHz or below.
3. If the AV_{CC} is less than 4.2V, divide the f_{AD} and hold A/D operating clock frequency (ϕ_{AD}) $f_{AD}/2$ or below.
4. Hold $V_{CC} = V_{ref}$.

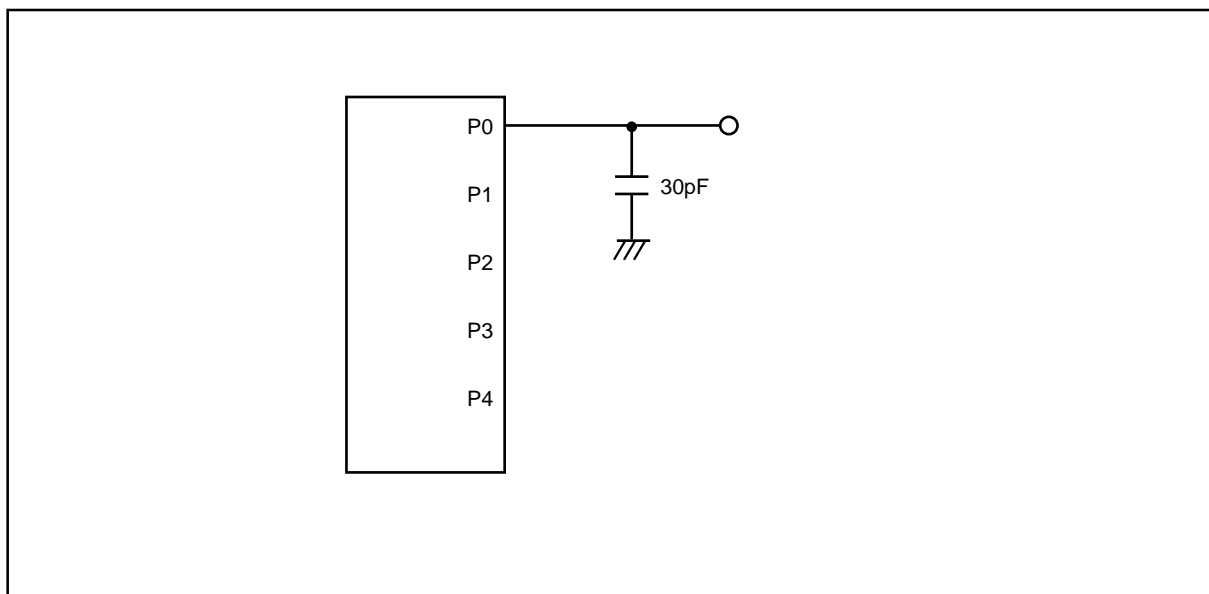

Figure 5.1 Port P0 to P4 measurement circuit

Table 5.4 Flash Memory Version Electrical Characteristics

Symbol	Parameter	Measuring condition	Standard			Unit
			Min.	Typ.	Max	
—	Program/erase endurance		100	—	—	times
—	Byte program time		—	50	400	μs
—	Block erase time		—	0.4	9	s
td(SR-ES)	Time delay from suspend request until erase suspend		—	—	8	ms
—	Erase Suspend Request Interval		10	—	—	ms
—	Program, Erase voltage		2.7	—	5.5	V
—	Read voltage		2.7	—	5.5	V
—	Program, Erase temperature		0	—	60	°C
—	Data hold time ⁽²⁾	Ambient temperature=55 °C	20	—	—	year

NOTES:

1. Referenced to $V_{CC1}=AV_{CC}=2.7$ to $5.5V$ at $T_{opr} = 0$ to 60 °C unless otherwise specified.
2. The data hold time includes time that the power supply is off or the clock is not supplied.

Table 5.5 Voltage Detection Circuit Electrical Characteristics

Symbol	Parameter	Measuring condition	Standard			Unit
			Min.	Typ.	Max.	
Vdet	Voltage detection level		3.3	3.8	4.3	V
—	Voltage detection interrupt request generating time ⁽²⁾		—	40	—	μs
—	Voltage detection circuit self consumption current	VC27=1, VCC=5.0V	—	600	—	nA
td(E-A)	Waiting time till voltage detection circuit operation starts ⁽³⁾		—	—	20	μs
Vccmin	Minimum value of microcomputer operation voltage		2.7	—	—	V

NOTES:

1. The measuring condition is $V_{CC}=AV_{CC}=2.7V$ to $5.5V$ and $T_{opr}= -40^{\circ}C$ to $85^{\circ}C$.
2. This shows the time until the voltage detection interrupt request is generated since the voltage passes Vdet.
3. This shows the required time until the voltage detection circuit operates when setting to "1" again after setting the VC27 bit in the VCR2 register to "0".

**Figure 5.2 Time delay from Suspend Request until Erase Suspend**

Table 5.6 Reset Circuit Electrical Characteristics (When Using Hardware Reset 2^(1, 3))

Symbol	Parameter	Measuring condition	Standard			Unit
			Min.	Typ.	Max.	
Vpor2	Power-on reset valid voltage	-20°C ≤ Topr < 85°C	—	—	Vdet	V
tw(Vpor2-Vdet)	Supply voltage rising time when power-on reset is canceled ⁽²⁾	-20°C ≤ Topr < 85°C, tw(por2) ≥ 0s ⁽⁴⁾	—	—	100	ms

NOTES:

1. The voltage detection circuit which is embedded in a microcomputer is a factor to generate the hardware reset 2. Refer to 5.1.2 Hardware Reset 2 of Hardware Manual for details.
2. This condition is not applicable when using with Vcc ≥ 1.0V.
3. When turning power on after the external power has been held below the valid voltage (Vpor1) for greater than 10 seconds, refer to Table 5.7 Reset Circuit Electrical Characteristics (When Not Using Hardware Reset 2).
4. tw(por2) is time to hold the external power below effective voltage (Vpor2).

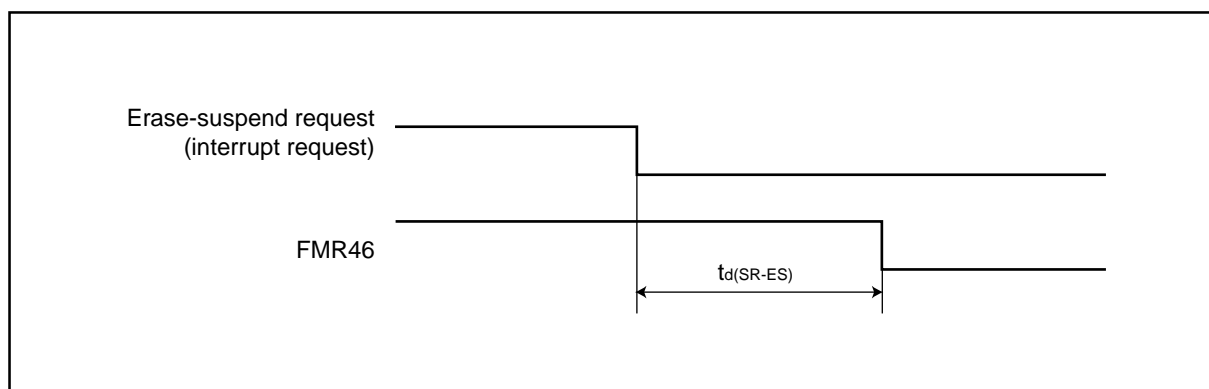
Table 5.7 Reset Circuit Electrical Characteristics (When Not Using Hardware Reset 2)

Symbol	Parameter	Measuring condition	Standard			Unit
			Min.	Typ.	Max.	
Vpor1	Power-on reset valid voltage	-20°C ≤ Topr < 85°C	—	—	0.1	V
tw(Vpor1-Vdet)	Supply voltage rising time when power-on reset is canceled	0°C ≤ Topr ≤ 85°C, tw(por1) ≥ 10s ⁽²⁾	—	—	100	ms
tw(Vpor1-Vdet)	Supply voltage rising time when power-on reset is canceled	-20°C ≤ Topr < 0°C, tw(por1) ≥ 30s ⁽²⁾	—	—	100	ms
tw(Vpor1-Vdet)	Supply voltage rising time when power-on reset is canceled	-20°C ≤ Topr < 0°C, tw(por1) ≥ 10s ⁽²⁾	—	—	1	ms
tw(Vpor1-Vdet)	Supply voltage rising time when power-on reset is canceled	0°C ≤ Topr ≤ 85°C, tw(por1) ≥ 1s ⁽²⁾	—	—	0.5	ms

NOTES:

1. When not using hardware reset 2, use with Vcc ≥ 2.7V.
2. tw(por1) is time to hold the external power below effective voltage (Vpor1).

**Figure 5.3 Reset Circuit Electrical Characteristics**

Table 5.8 High-speed On-Chip Oscillator Circuit Electrical Characteristics

Symbol	Parameter	Measuring condition	Standard			Unit
			Min.	Typ.	Max.	
—	High-speed on-chip oscillator frequency 1 / (td(HRoffset)+td(HR)) when the reset is released	VCC=5.0V, Topr=25 °C Set "4016" in the HR1 register	6	8	10	MHz
td(HRoffset)	Settable high-speed on-chip oscillator minimum period	VCC=5.0V, Topr=25 °C Set "0016" in the HR1 register	—	61	—	ns
td(HR)	High-speed on-chip oscillator period adjusted unit	Differences when setting "0116" and "0016" in the HR register	—	1	—	ns
—	High-speed on-chip oscillator frequency temperature dependence(1)	Frequency fluctuation in temperature range of -10 °C to 50 °C	—	±5	—	%
—	High-speed on-chip oscillator frequency temperature dependence(2)	Frequency fluctuation in temperature range of -40 °C to 85 °C	—	±10	—	%

NOTES:

1. The measuring condition is Vcc=AVcc=5.0 V and Topr=25 °C.

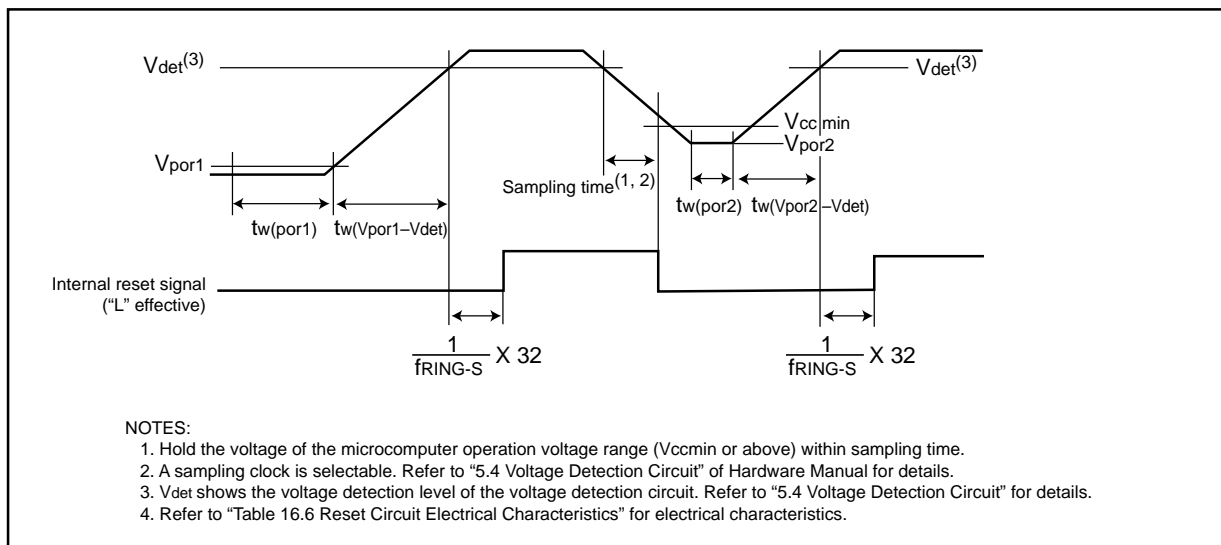
Table 5.9 Power Circuit Timing Characteristics

Symbol	Parameter	Measuring condition	Standard			Unit
			Min.	Typ.	Max.	
td(P-R)	Time for internal power supply stabilization during powering-on ⁽²⁾		1	—	2000	μs
td(R-S)	STOP release time ⁽³⁾		—	—	150	μs

NOTES:

1. The measuring condition is Vcc=AVcc=2.7 to 5.5 V and Topr=25 °C.
2. This shows the wait time until the internal power supply generating circuit is stabilized during power-on.
3. This shows the time until BCLK starts from the interrupt acknowledgement to cancel stop mode.

Table 5.10 Electrical Characteristics (1) [Vcc=5V]

Symbol	Parameter		Measuring condition	Standard			Unit	
				Min.	Typ.	Max.		
VOH	"H" output voltage	Except XOUT	I _{OH} =-5mA	Vcc-2.0	—	Vcc	V	
			I _{OH} =-200μA	Vcc-0.3	—	Vcc	V	
		XOUT	Drive ability HIGH	I _{OH} =-1 mA	Vcc-2.0	—	Vcc	V
			Drive ability LOW	I _{OH} =-500μA	Vcc-2.0	—	Vcc	V
VOL	"L" output voltage	Except P10 to P17, XOUT	I _{OL} = 5 mA	—	—	2.0	V	
			I _{OL} = 200 μA	—	—	0.45	V	
		P10 to P17	Drive capacity HIGH	I _{OL} = 15 mA	—	—	2.0	V
			Drive capacity LOW	I _{OL} = 5 mA	—	—	2.0	V
			Drive capacity LOW	I _{OL} = 200 μA	—	—	0.45	V
		XOUT	Drive capacity HIGH	I _{OL} = 1 mA	—	—	2.0	V
			Drive capacity LOW	I _{OL} =500 μA	—	—	2.0	V
VT+·VT-	Hysteresis	INT0, INT1, INT2, INT3, KI0, KI1, KI2, KI3, CNTR0, CNTR1, TCIN, RxD0, RxD1, P45		0.2	—	1.0	V	
		RESET		0.2	—	2.2	V	
I _{IH}	"H" input current		V _I =5V	—	—	5.0	μA	
I _{IL}	"L" input current		V _I =0V	—	—	-5.0	μA	
R _{PULLUP}	Pull-up resistance		V _I =0V	30	50	167	kΩ	
R _{XIN}	Feedback resistance	XIN		—	1.0	—	MΩ	
f _{RING-S}	Low-speed on-chip oscillator frequency			40	125	250	kHz	
V _{RAM}	RAM retention voltage		At stop mode	2.0	—	—	V	

NOTES:

1. Referenced to Vcc = AVcc = 4.2 to 5.5V at Topr = -20 to 85 °C / -40 to 85 °C, f(XIN)=20MHz unless otherwise specified.

Table 5.11 Electrical Characteristics (2) [Vcc=5V]

Symbol	Parameter	Measuring condition	Standard			Unit	
			Min.	Typ.	Max.		
I _{CC}	Power supply current (V _{CC} =3.3 to 5.5V) In single-chip mode, the output pins are open and other pins are V _{SS}	High-speed mode X _{IN} =20 MHz (square wave) High-speed on-chip oscillator off Low-speed on-chip oscillator on=125 kHz No division	—	9	15	mA	
			X _{IN} =16 MHz (square wave) High-speed on-chip oscillator off Low-speed on-chip oscillator on=125 kHz No division	—	8	14	mA
				X _{IN} =10 MHz (square wave) High-speed on-chip oscillator off Low-speed on-chip oscillator on=125 kHz No division	—	5	—
		Medium-speed mode X _{IN} =20 MHz (square wave) High-speed on-chip oscillator off Low-speed on-chip oscillator on=125 kHz Division by 8	—		4	—	mA
			X _{IN} =16 MHz (square wave) High-speed on-chip oscillator off Low-speed on-chip oscillator on=125 kHz Division by 8	—	3	—	mA
				X _{IN} =10 MHz (square wave) High-speed on-chip oscillator off Low-speed on-chip oscillator on=125 kHz Division by 8	—	2	—
		High-speed on-chip oscillator mode Main clock off High-speed on-chip oscillator on=8 MHz Low-speed on-chip oscillator on=125 kHz No division	—		4	8	mA
			Main clock off High-speed on-chip oscillator on=8 MHz Low-speed on-chip oscillator on=125 kHz Division by 8	—	1.5	—	mA
		Low-speed on-chip oscillator mode Main clock off High-speed on-chip oscillator off Low-speed on-chip oscillator on=125 kHz Division by 8		—	470	900	μA
			Wait mode Main clock off High-speed on-chip oscillator off Low-speed on-chip oscillator on=125 kHz When a WAIT instruction is executed ⁽¹⁾ Peripheral clock operation VC27="0"	—	40	80	μA
		Wait mode Main clock off High-speed on-chip oscillator off Low-speed on-chip oscillator on=125 kHz When a WAIT instruction is executed ⁽¹⁾ Peripheral clock off VC27="0"		—	38	76	μA
			Stop mode Main clock off, Topr = 25 °C High-speed on-chip oscillator off Low-speed on-chip oscillator off CM10="1" Peripheral clock off VC27="0"	—	0.8	3.0	μA

NOTES:

1. Timer Y is operated with timer mode.
2. Referenced to V_{CC} = AV_{CC} = 4.2 to 5.5V at Topr = -20 to 85 °C / -40 to 85 °C, f(X_{IN})=20MHz unless otherwise specified.

Timing requirements (Unless otherwise noted: $V_{CC} = 5V$, $V_{SS} = 0V$ at $T_{opr} = 25\text{ }^{\circ}C$) [$V_{CC}=5V$]**Table 5.12 XIN input**

Symbol	Parameter	Standard		Unit
		Min.	Max.	
tC(XIN)	XIN input cycle time	50	–	ns
tWH(XIN)	XIN input HIGH pulse width	25	–	ns
tWL(XIN)	XIN input LOW pulse width	25	–	ns

Table 5.13 CNTR0 input, CNTR1 input, $\overline{INT2}$ input

Symbol	Parameter	Standard		Unit
		Min.	Max.	
tC(CNTR0)	CNTR0 input cycle time	100	–	ns
tWH(CNTR0)	CNTR0 input HIGH pulse width	40	–	ns
tWL(CNTR0)	CNTR0 input LOW pulse width	40	–	ns

Table 5.14 TCIN input, $\overline{INT3}$ input

Symbol	Parameter	Standard		Unit
		Min.	Max.	
tC(TCIN)	TCIN input cycle time	400 ⁽¹⁾	–	ns
tWH(TCIN)	TCIN input HIGH pulse width	200 ⁽²⁾	–	ns
tWL(TCIN)	TCIN input LOW pulse width	200 ⁽²⁾	–	ns

NOTES:

1. When using the Timer C input capture mode, adjust the cycle time above (1/ Timer C count source frequency x 3).
2. When using the Timer C input capture mode, adjust the pulse width above (1/ Timer C count source frequency x 1.5).

Table 5.15 Serial Interface

Symbol	Parameter	Standard		Unit
		Min.	Max.	
tC(CK)	CLKi input cycle time	200	–	ns
tW(CKH)	CLKi input HIGH pulse width	100	–	ns
tW(CKL)	CLKi input LOW pulse width	100	–	ns
td(C-Q)	TxDi output delay time	–	80	ns
th(C-Q)	TxDi hold time	0	–	ns
tsu(D-C)	RxDi input setup time	35	–	ns
th(C-D)	RxDi input hold time	90	–	ns

Table 5.16 External interrupt $\overline{INT0}$ input

Symbol	Parameter	Standard		Unit
		Min.	Max.	
tW(INH)	$\overline{INT0}$ input HIGH pulse width	250 ⁽¹⁾	–	ns
tW(INL)	$\overline{INT0}$ input LOW pulse width	250 ⁽²⁾	–	ns

NOTES:

1. When selecting the digital filter by the $\overline{INT0}$ input filter select bit, use the $\overline{INT0}$ input HIGH pulse width to the greater value, either (1/ digital filter clock frequency x 3) or the minimum value of standard.
2. When selecting the digital filter by the $\overline{INT0}$ input filter select bit, use the $\overline{INT0}$ input LOW pulse width to the greater value, either (1/ digital filter clock frequency x 3) or the minimum value of standard.

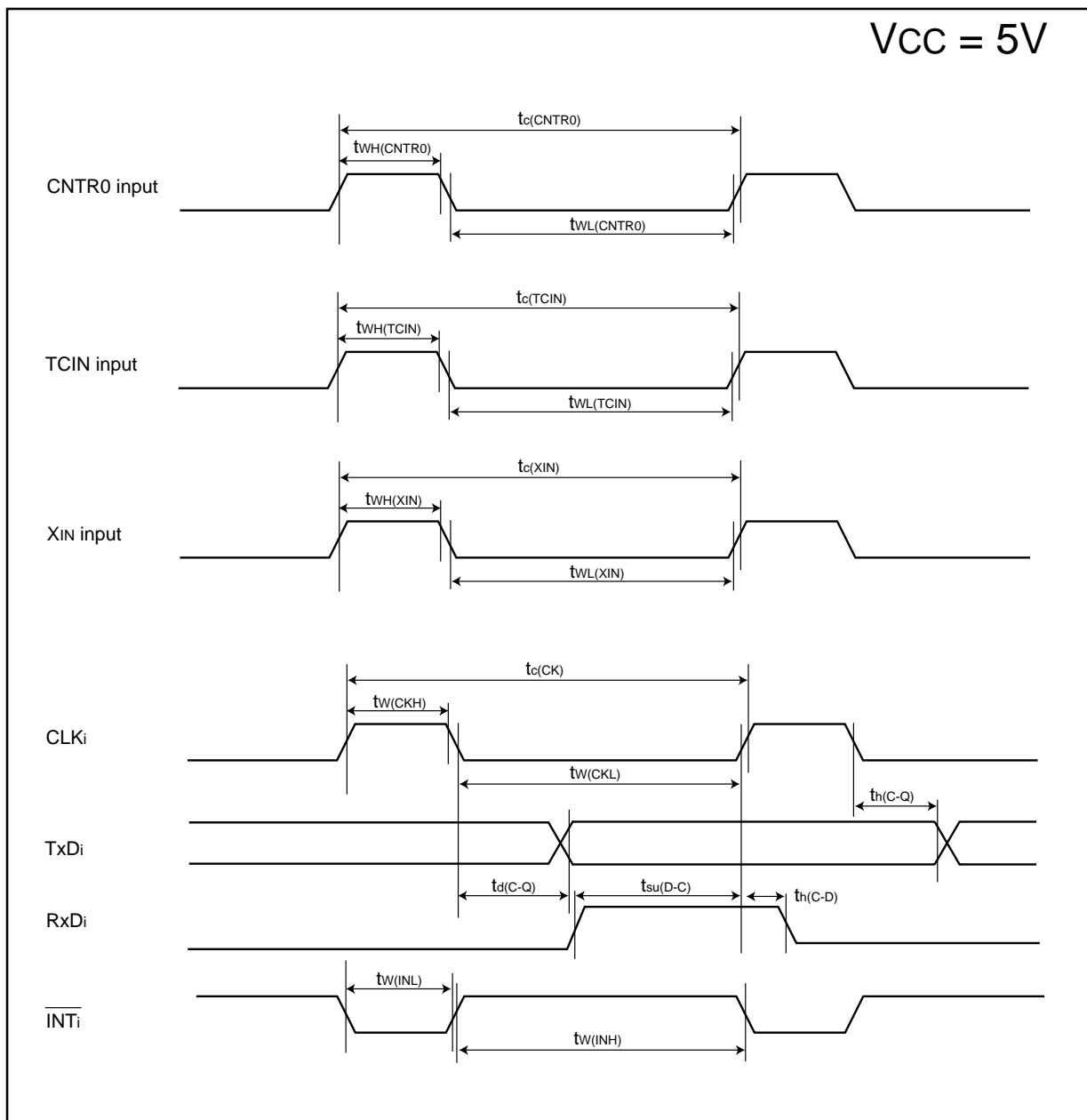

Figure 5.4 Vcc=5V timing diagram

Table 5.17 Electrical Characteristics (3) [Vcc=3V]

Symbol	Parameter		Measuring condition		Standard			Unit
					Min.	Typ.	Max.	
VOH	"H" output voltage	Except XOUT	IOH=-1mA		Vcc-0.5	—	Vcc	V
		XOUT	Drive capacity HIGH	IOH=-0.1 mA	Vcc-0.5	—	Vcc	v
			Drive capacity LOW	IOH=-50 μA	Vcc-0.5	—	Vcc	v
VOL	"L" output voltage	Except P10 to P17, XOUT	IOL= 1 mA		—	—	0.5	V
		P10 to P17	Drive capacity HIGH	IOL= 2 mA	—	—	0.5	V
			Drive capacity LOW	IOL= 1 mA	—	—	0.5	v
		XOUT	Drive capacity HIGH	IOL= 0.1 mA	—	—	0.5	v
			Drive capacity LOW	IOL=50 μA	—	—	0.5	v
VT+-VT-	Hysteresis	INT0, INT1, INT2, INT3, K10, K11, K12, K13, CNTR0, CNTR1, TCIN, RxD0, RxD1, P45			0.2	—	0.8	v
		RESET			0.2	—	1.8	v
IiH	"H" input current			Vi=3V	—	—	4.0	μA
IiL	"L" input current			Vi=0V	—	—	-4.0	μA
RPULLUP	Pull-up resistance			Vi=0V	66	160	500	kΩ
RiXIN	Feedback resistance	XIN			—	3.0	—	MΩ
fRING-S	Low-speed on-chip oscillator frequency				40	125	250	kHz
V _{RAM}	RAM retention voltage		At stop mode		2.0	—	—	V

NOTES:

1. Referenced to Vcc = AVcc = 2.7 to 3.3V at Topr = -20 to 85 °C / -40 to 85 °C, f(XIN)=10MHz unless otherwise specified.

Table 5.18 Electrical Characteristics (4) [Vcc=3V]

Symbol	Parameter	Measuring condition	Standard			Unit	
			Min.	Typ.	Max.		
I _{cc}	Power supply current (V _{cc} =2.7 to 3.3V) In single-chip mode, the output pins are open and other pins are V _{ss}	High-speed mode X _{IN} =20 MHz (square wave) High-speed on-chip oscillator off Low-speed on-chip oscillator on=125 kHz No division	—	8	13	mA	
			X _{IN} =16 MHz (square wave) High-speed on-chip oscillator off Low-speed on-chip oscillator on=125 kHz No division	—	7	12	mA
				X _{IN} =10 MHz (square wave) High-speed on-chip oscillator off Low-speed on-chip oscillator on=125 kHz No division	—	5	—
		Medium-speed mode X _{IN} =20 MHz (square wave) High-speed on-chip oscillator off Low-speed on-chip oscillator on=125 kHz Division by 8	—		3	—	mA
			X _{IN} =16 MHz (square wave) High-speed on-chip oscillator off Low-speed on-chip oscillator on=125 kHz Division by 8	—	2.5	—	mA
				X _{IN} =10 MHz (square wave) High-speed on-chip oscillator off Low-speed on-chip oscillator on=125 kHz Division by 8	—	1.6	—
		High-speed on-chip oscillator mode Main clock off High-speed on-chip oscillator on=8 MHz Low-speed on-chip oscillator on=125 kHz No division	—		3.5	7.5	mA
			Main clock off High-speed on-chip oscillator on=8 MHz Low-speed on-chip oscillator on=125 kHz Division by 8	—	1.5	—	mA
		Low-speed on-chip oscillator mode Main clock off High-speed on-chip oscillator off Low-speed on-chip oscillator on=125 kHz Division by 8		—	420	800	μA
		Wait mode Main clock off High-speed on-chip oscillator off Low-speed on-chip oscillator on=125 kHz When a WAIT instruction is executed ⁽¹⁾ Peripheral clock operation VC27="0"	—	37	74	μA	
Wait mode Main clock off High-speed on-chip oscillator off Low-speed on-chip oscillator on=125 kHz When a WAIT instruction is executed ⁽¹⁾ Peripheral clock off VC27="0"	—		35	70	μA		
	Stop mode Main clock off, Topr = 25 °C High-speed on-chip oscillator off Low-speed on-chip oscillator off CM10="1" Peripheral clock off VC27="0"	—	0.7	3.0	μA		

NOTES:

1. Timer Y is operated with timer mode.
2. Referenced to V_{cc} = AV_{cc} = 2.7 to 3.3V at Topr = -20 to 85 °C / -40 to 85 °C, f(X_{IN})=10MHz unless otherwise specified.

Timing requirements (Unless otherwise noted: Vcc = 3V, Vss = 0V at Topr = 25 °C) [Vcc=3V]**Table 5.19 XIN input**

Symbol	Parameter	Standard		Unit
		Min.	Max.	
tC(XIN)	XIN input cycle time	100	–	ns
tWH(XIN)	XIN input HIGH pulse width	40	–	ns
tWL(XIN)	XIN input LOW pulse width	40	–	ns

Table 5.20 CNTR0 input, CNTR1 input, INT2 input

Symbol	Parameter	Standard		Unit
		Min.	Max.	
tC(CNTR0)	CNTR0 input cycle time	300	–	ns
tWH(CNTR0)	CNTR0 input HIGH pulse width	120	–	ns
tWL(CNTR0)	CNTR0 input LOW pulse width	120	–	ns

Table 5.21 TCIN input, INT3 input

Symbol	Parameter	Standard		Unit
		Min.	Max.	
tC(TCIN)	TCIN input cycle time	1200 ⁽¹⁾	–	ns
tWH(TCIN)	TCIN input HIGH pulse width	600 ⁽²⁾	–	ns
tWL(TCIN)	TCIN input LOW pulse width	600 ⁽²⁾	–	ns

NOTES:

1. When using the Timer C input capture mode, adjust the cycle time above (1/ Timer C count source frequency x 3).
2. When using the Timer C input capture mode, adjust the pulse width above (1/ Timer C count source frequency x 1.5).

Table 5.22 Serial Interface

Symbol	Parameter	Standard		Unit
		Min.	Max.	
tC(CLK)	CLKi input cycle time	300	–	ns
tW(CLKH)	CLKi input HIGH pulse width	150	–	ns
tW(CLKL)	CLKi input LOW pulse width	150	–	ns
td(C-Q)	TxDi output delay time	–	160	ns
th(C-Q)	TxDi hold time	0	–	ns
tsu(D-C)	RxDi input setup time	55	–	ns
th(C-D)	RxDi input hold time	90	–	ns

Table 5.23 External interrupt INT0 input

Symbol	Parameter	Standard		Unit
		Min.	Max.	
tW(INH)	INT0 input HIGH pulse width	380 ⁽¹⁾	–	ns
tW(INL)	INT0 input LOW pulse width	380 ⁽²⁾	–	ns

NOTES:

1. When selecting the digital filter by the INT0 input filter select bit, use the INT0 input HIGH pulse width to the greater value, either (1/ digital filter clock frequency x 3) or the minimum value of standard.
2. When selecting the digital filter by the INT0 input filter select bit, use the INT0 input LOW pulse width to the greater value, either (1/ digital filter clock frequency x 3) or the minimum value of standard.

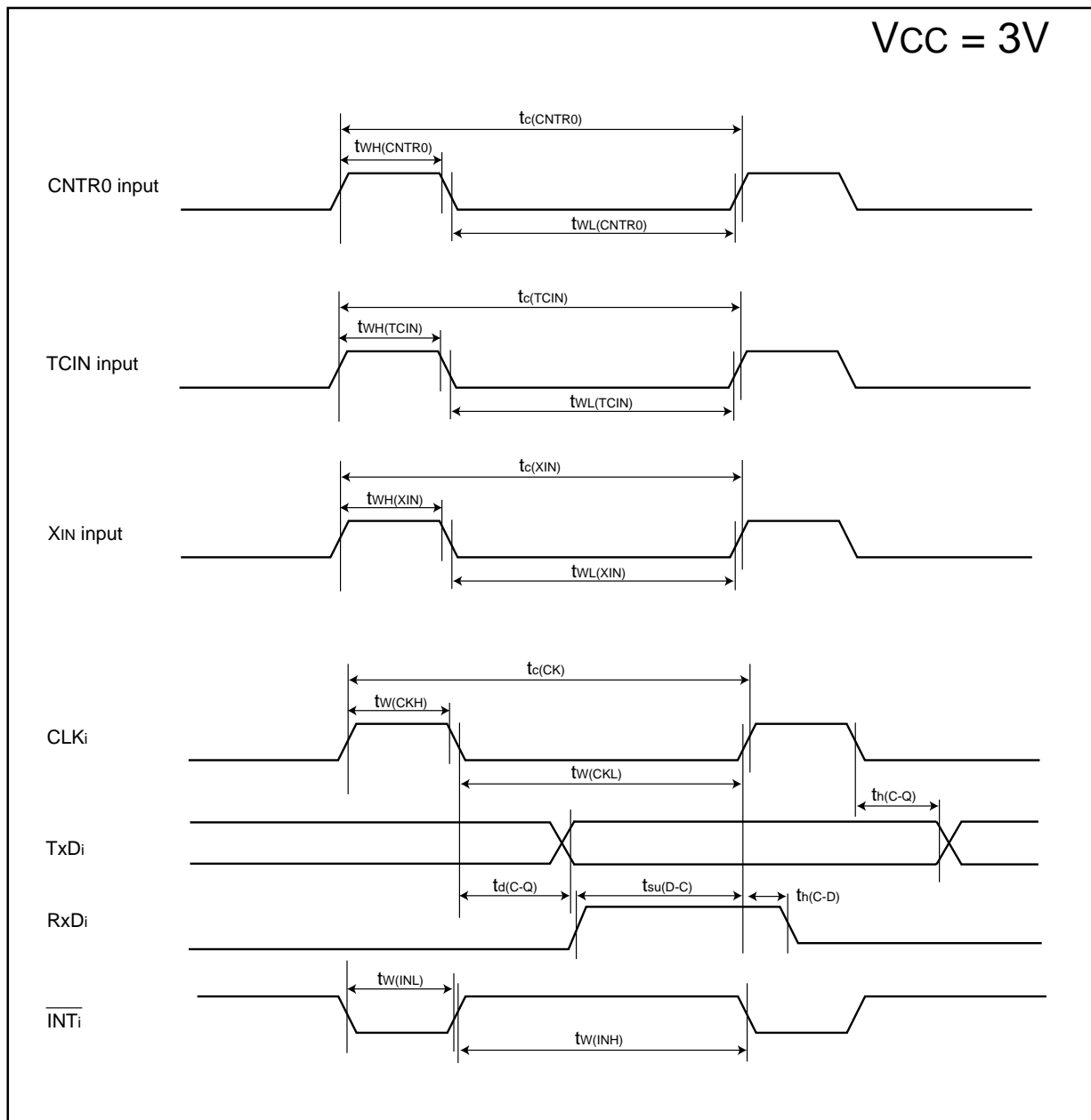
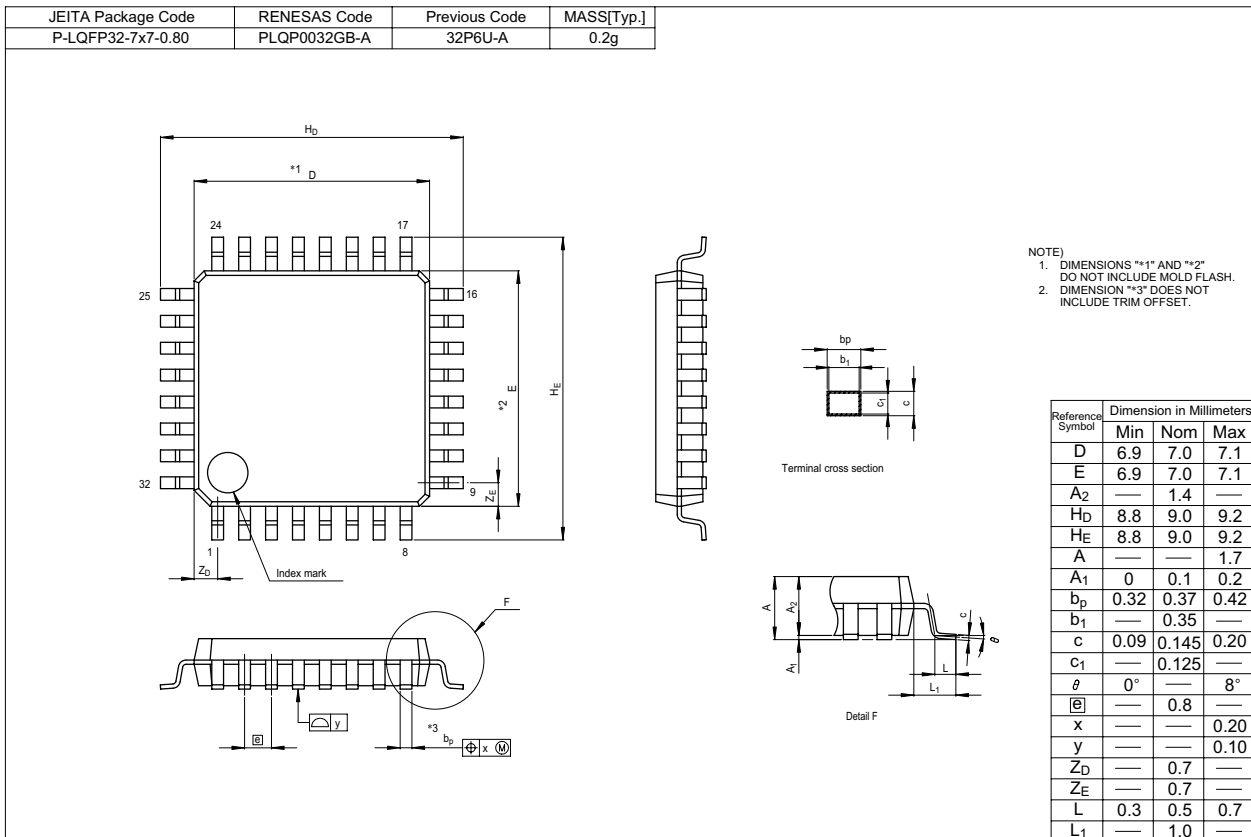

Figure 5.5 Vcc=3V timing diagram

Package Dimensions



REVISION HISTORY

R8C/11 Group Datasheet

Rev.	Date	Description	
		Page	Summary
1.00	Jun. 19, 2003		First edition issued
1.10	Sep. 08, 2003	2 5 6 10 12 14	Table 1.1: Shortest instruction execution time and f(XIN) changed Figure 1.3: Pin name changed from TXOUT to CNTR0 Table 1.3: Pin name changed from TXOUT to CNTR0 The value of HR1 register after reset changed The value of TC register after reset changed Chapter "5. Electrical Characteristics" added
1.20	Oct. 31, 2003	2 6 11 14 15 17 19 20 21 22 23 24 25	Table 1.1: Power consumption values added Table 1.3: Resistor value for CNVss and MODE deleted Register name of address 005016 modified from CMP2IC to CMP1IC, register name of address 005C16 modified from CMP1IC to CMP0IC Table 5.2: Note 3 and Note 4 deleted tsamp in Table 5.3 deleted Figure 5.1 added Table 5.10: Vcc changed from "4.2 to 5.5V" to "3.3V to 5.5V", low-power on-chip oscillator changed from "on 100kHz" to "125kHz", XIN=5MHz deleted and XIN=10MHz added in high-speed mode and medium-speed mode, VC27="0" added in stop mode measuring condition, data added and modified Table 11 to Table 15 added Figure 5.2 added Table 5.16: Note 1, f(BCLK)=5 MHz changed to 10 MHz Table 5.17: low-power ring oscillator changed from "on 100kHz" to "125kHz", XIN=5MHz deleted and XIN=10MHz added in high-speed mode and medium-speed mode, VC27="0" added in stop mode measuring condition, data added and modified Table 5.18 to Table 5.22 added Figure 5.3 added
1.30	Dec 05, 2003	4 15	Table 1.2 : ** deleted Table 5.4 revised
1.40	Sep 30, 2004	all pages 2 5 6 9 10-13 12 14 15 16 17 18	Words standardized (on-chip oscillator, serial interface, A/D) Table 1.1 revised Figure 1.3, NOTES 3 added Table 1.3 revised Figure 3.1, NOTES added One body sentence in chapter 4 added ; Title of Table 4.1 to 4.4 added Table 4.3 revised ; Table 4.4 revised Table 5.2 revised Table 5.3 revised Table 5.4 revised ; Table 16.5 revised Table 5.6, 5.7 adn 5.8 revised ; Figure 5.3 revised Table 5.9 revised ; Table 5.10 revised

REVISION HISTORY

R8C/11 Group Datasheet

Rev.	Date	Description	
		Page	Summary
1.40	Sep 30, 2004	20	Table 5.12 revised ; Table 5.16 revised
		22	Table 16.17 revised
		24	Table 16.19 revised
1.50	Apr.27.2005	4	Table 1.2, Figure 1.2 package name revised
		5	Figure 1.3 package name revised
		10	Table 4.1 revised
		12	Table 4.3 revised
		15	Table 5.3 partly revised
		16	Table 5.4 partly added
		17	Table 5.6, Table 5.7 revised
		18	Table 5.9, Table 10 partly revised
		22	Table 5.17 partly revised
26	Package Dimensions revised		
1.60	Jan.27.2006	2	Table 1.1 Performance outline revised
		3	Figure 1.1 Block diagram partly revised
		4	1.4 Product Information, title of Table 1.2 "Product List" → "Product Informaton" revised
			Figure 1.2 Type No., Memory Size, and Package partly revised
		6	Table 1.3 Pin description revised
		7-8	2 Central Processing Unit (CPU) revised
			Figure 2.1 CPU register revised
		10	Table 4.1 SFR Information(1) NOTES:1 revised
		11	Table 4.2 SFR Information(2) NOTES:1 revised
		12	Table 4.3 SFR Information(3); 0081 ₁₆ : "Prescaler Y" → "Prescaler Y Register" 0082 ₁₆ : "Timer Y Secondary" → "Timer Y Secondary Register" 0083 ₁₆ : "Timer Y Primary" → "Timer Y Primary Register" 0085 ₁₆ : "Prescaler Z" → "Prescaler Z Register" 0086 ₁₆ : "Timer Z Secondary" → "Timer Z Secondary Register" 0087 ₁₆ : "Timer Z Primary" → "Timer Z Primary Register" 008C ₁₆ : "Prescaler X" → "Prescaler X Register" revised NOTES:1, 2 revised
		13	Table 4.4 SFR Information(4) NOTES:1 revised
		14	Table 5.2 Recommended Operating Conditions; NOTES: 1, 2, 3 revised
		15	Table 5.3 A/D Conversion Characteristics; "A/D operation clock frequency" → "A/D operating clock frequency" revised NOTES: 1, 2, 3, 4 revised
		16	Table 5.4 Flash Memory (Program ROM) Electrical Characteristics; "Topr" → "Ambient temperature" revised Measuring condition of byte program time and block erase time deleted
		17	Table 5.6 Reset Circuit Electrical Characteristics (When Using Hardware Reset 2) NOTES: 3 revised
		18	Table 5.8 High-speed On-Chip Oscillator Circuit Electrical Characteristics; "High-speed on-chip oscillator temperature dependence" → "High-speed on-chip oscillator frequency temperature dependence" revised Table 5.10 Electrical Characteristics (1) [V _{CC} =5V]; "P1 ₀ to P1 ₇ Except Xout" → "Except P1 ₀ to P1 ₇ , Xout" revised

REVISION HISTORY

R8C/11 Group Datasheet

Rev.	Date	Description	
		Page	Summary
1.60	Jan.27.2006	19	Table 5.11 Electrical Characteristics (2) [Vcc=5V] NOTES: 1, 2 revised Measuring condition Stop mode: "Topr = 25 °C"
		22	Table 5.17 Electrical Characteristics (3) [Vcc=3V] "P1 ₀ to P1 ₇ Except X _{OUT} " → "Except P1 ₀ to P1 ₇ , X _{OUT} " revised
		23	Table 5.18 Electrical Characteristics (4) [Vcc=3V] NOTES: 1, 2 revised Measuring condition Stop mode: "Topr = 25 °C"

Keep safety first in your circuit designs!

1. Renesas Technology Corp. puts the maximum effort into making semiconductor products better and more reliable, but there is always the possibility that trouble may occur with them. Trouble with semiconductors may lead to personal injury, fire or property damage.
Remember to give due consideration to safety when making your circuit designs, with appropriate measures such as (i) placement of substitutive, auxiliary circuits, (ii) use of nonflammable material or (iii) prevention against any malfunction or mishap.

Notes regarding these materials

1. These materials are intended as a reference to assist our customers in the selection of the Renesas Technology Corp. product best suited to the customer's application; they do not convey any license under any intellectual property rights, or any other rights, belonging to Renesas Technology Corp. or a third party.
 2. Renesas Technology Corp. assumes no responsibility for any damage, or infringement of any third-party's rights, originating in the use of any product data, diagrams, charts, programs, algorithms, or circuit application examples contained in these materials.
 3. All information contained in these materials, including product data, diagrams, charts, programs and algorithms represents information on products at the time of publication of these materials, and are subject to change by Renesas Technology Corp. without notice due to product improvements or other reasons. It is therefore recommended that customers contact Renesas Technology Corp. or an authorized Renesas Technology Corp. product distributor for the latest product information before purchasing a product listed herein.
The information described here may contain technical inaccuracies or typographical errors.
Renesas Technology Corp. assumes no responsibility for any damage, liability, or other loss rising from these inaccuracies or errors.
Please also pay attention to information published by Renesas Technology Corp. by various means, including the Renesas Technology Corp. Semiconductor home page (<http://www.renesas.com>).
 4. When using any or all of the information contained in these materials, including product data, diagrams, charts, programs, and algorithms, please be sure to evaluate all information as a total system before making a final decision on the applicability of the information and products. Renesas Technology Corp. assumes no responsibility for any damage, liability or other loss resulting from the information contained herein.
 5. Renesas Technology Corp. semiconductors are not designed or manufactured for use in a device or system that is used under circumstances in which human life is potentially at stake. Please contact Renesas Technology Corp. or an authorized Renesas Technology Corp. product distributor when considering the use of a product contained herein for any specific purposes, such as apparatus or systems for transportation, vehicular, medical, aerospace, nuclear, or undersea repeater use.
 6. The prior written approval of Renesas Technology Corp. is necessary to reprint or reproduce in whole or in part these materials.
 7. If these products or technologies are subject to the Japanese export control restrictions, they must be exported under a license from the Japanese government and cannot be imported into a country other than the approved destination.
Any diversion or reexport contrary to the export control laws and regulations of Japan and/or the country of destination is prohibited.
 8. Please contact Renesas Technology Corp. for further details on these materials or the products contained therein.
-



RENESAS SALES OFFICES

<http://www.renesas.com>

Refer to "<http://www.renesas.com/en/network>" for the latest and detailed information.

Renesas Technology America, Inc.

450 Holger Way, San Jose, CA 95134-1368, U.S.A
Tel: <1> (408) 382-7500, Fax: <1> (408) 382-7501

Renesas Technology Europe Limited

Dukes Meadow, Millboard Road, Bourne End, Buckinghamshire, SL8 5FH, U.K.
Tel: <44> (1628) 585-100, Fax: <44> (1628) 585-900

Renesas Technology (Shanghai) Co., Ltd.

Unit 205, AZIA Center, No.133 Yincheng Rd (n), Pudong District, Shanghai 200120, China
Tel: <86> (21) 5877-1818, Fax: <86> (21) 6887-7898

Renesas Technology Hong Kong Ltd.

7th Floor, North Tower, World Finance Centre, Harbour City, 1 Canton Road, Tsimshatsui, Kowloon, Hong Kong
Tel: <852> 2265-6688, Fax: <852> 2730-6071

Renesas Technology Taiwan Co., Ltd.

10th Floor, No.99, Fushing North Road, Taipei, Taiwan
Tel: <886> (2) 2715-2888, Fax: <886> (2) 2713-2999

Renesas Technology Singapore Pte. Ltd.

1 Harbour Front Avenue, #06-10, Keppel Bay Tower, Singapore 098632
Tel: <65> 6213-0200, Fax: <65> 6278-8001

Renesas Technology Korea Co., Ltd.

Kukje Center Bldg. 18th Fl., 191, 2-ka, Hangang-ro, Yongsan-ku, Seoul 140-702, Korea
Tel: <82> (2) 796-3115, Fax: <82> (2) 796-2145

Renesas Technology Malaysia Sdn. Bhd

Unit 906, Block B, Menara Amcorp, Amcorp Trade Centre, No.18, Jalan Persiaran Barat, 46050 Petaling Jaya, Selangor Darul Ehsan, Malaysia
Tel: <603> 7955-9390, Fax: <603> 7955-9510

Mouser Electronics

Authorized Distributor

Click to View Pricing, Inventory, Delivery & Lifecycle Information:

Renesas Electronics:

[R5F21112DFP#U0](#) [R5F21114FP#W4](#) [R5F21113DFP#U0](#) [R5F21114FP#U0](#) [R5F21114DFP#U0](#) [R5F21113FP#U0](#)
[R5F21112FP#U0](#)

Компания «Океан Электроники» предлагает заключение долгосрочных отношений при поставках импортных электронных компонентов на взаимовыгодных условиях!

Наши преимущества:

- Поставка оригинальных импортных электронных компонентов напрямую с производств Америки, Европы и Азии, а так же с крупнейших складов мира;
- Широкая линейка поставок активных и пассивных импортных электронных компонентов (более 30 млн. наименований);
- Поставка сложных, дефицитных, либо снятых с производства позиций;
- Оперативные сроки поставки под заказ (от 5 рабочих дней);
- Экспресс доставка в любую точку России;
- Помощь Конструкторского Отдела и консультации квалифицированных инженеров;
- Техническая поддержка проекта, помощь в подборе аналогов, поставка прототипов;
- Поставка электронных компонентов под контролем ВП;
- Система менеджмента качества сертифицирована по Международному стандарту ISO 9001;
- При необходимости вся продукция военного и аэрокосмического назначения проходит испытания и сертификацию в лаборатории (по согласованию с заказчиком);
- Поставка специализированных компонентов военного и аэрокосмического уровня качества (Xilinx, Altera, Analog Devices, Intersil, Interpoint, Microsemi, Actel, Aeroflex, Peregrine, VPT, Syfer, Eurofarad, Texas Instruments, MS Kennedy, Miteq, Cobham, E2V, MA-COM, Hittite, Mini-Circuits, General Dynamics и др.);

Компания «Океан Электроники» является официальным дистрибьютором и эксклюзивным представителем в России одного из крупнейших производителей разъемов военного и аэрокосмического назначения «JONHON», а так же официальным дистрибьютором и эксклюзивным представителем в России производителя высокотехнологичных и надежных решений для передачи СВЧ сигналов «FORSTAR».



JONHON

«JONHON» (основан в 1970 г.)

Разъемы специального, военного и аэрокосмического назначения:

(Применяются в военной, авиационной, аэрокосмической, морской, железнодорожной, горно- и нефтедобывающей отраслях промышленности)

«FORSTAR» (основан в 1998 г.)

ВЧ соединители, коаксиальные кабели, кабельные сборки и микроволновые компоненты:

(Применяются в телекоммуникациях гражданского и специального назначения, в средствах связи, РЛС, а так же военной, авиационной и аэрокосмической отраслях промышленности).



Телефон: 8 (812) 309-75-97 (многоканальный)

Факс: 8 (812) 320-03-32

Электронная почта: ocean@oceanchips.ru

Web: <http://oceanchips.ru/>

Адрес: 198099, г. Санкт-Петербург, ул. Калинина, д. 2, корп. 4, лит. А