



**ATTENTION**  
OBSERVE PRECAUTIONS  
FOR HANDLING  
ELECTROSTATIC  
DISCHARGE  
SENSITIVE  
DEVICES

Part Number: AAAF3529LSEEZGKQBKS

Hyper Red  
Green  
Blue

### Features

- Outstanding material efficiency.
- Low power consumption.
- Can produce any color in visible spectrum, including white light.
- Suitable for all SMD assembly and solder process.
- Available on tape and reel.
- Package: 2000pcs / reel .
- Moisture sensitivity level : level 3.
- Low current IF=2mA operating.
- RoHS compliant.

### Descriptions

- The Hyper Red source color devices are made with AlGaInP on GaAs substrate Light Emitting Diode.
- The Green source color devices are made with InGaN on Sapphire Light Emitting Diode.
- The Blue source color devices are made with InGaN on Sapphire Light Emitting Diode.
- Electrostatic discharge and power surge could damage the LEDs.
- It is recommended to use a wrist band or anti-electrostatic glove when handling the LEDs.
- All devices, equipments and machineries must be electrically grounded.

### Package Dimensions

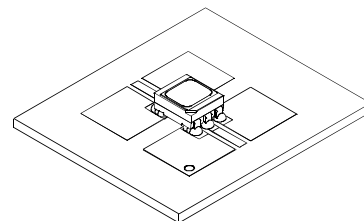
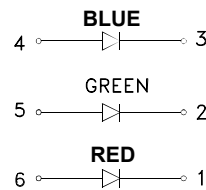
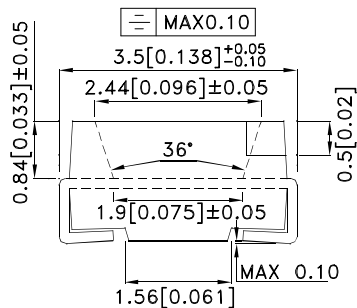
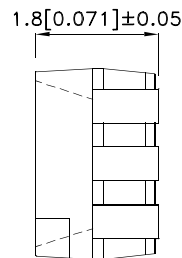
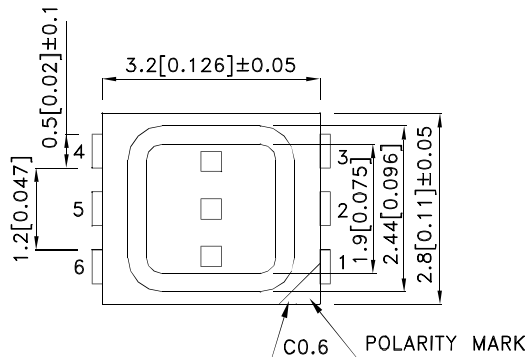

#### Notes:

1. All dimensions are in millimeters (inches).
2. Tolerance is  $\pm 0.25(0.01")$  unless otherwise noted.
3. The specifications, characteristics and technical data described in the datasheet are subject to change without prior notice.
4. The device has a single mounting surface. The device must be mounted according to the specifications.



## Handling Precautions

Compare to epoxy encapsulant that is hard and brittle, silicone is softer and flexible. Although its characteristic significantly Orangeuces thermal stress, it is more susceptible to damage by external mechanical force.

As a result, special handling precautions need to be observed during assembly using silicone encapsulated LED products. Failure to comply might lead to damage and premature failure of the LED.

1. Handle the component along the side surfaces by using forceps or appropriate tools.

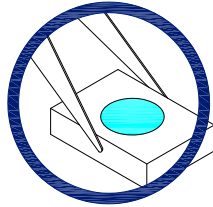

2. Do not directly touch or handle the silicone lens surface. It may damage the internal circuitry.

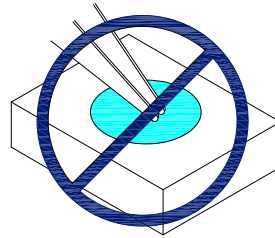
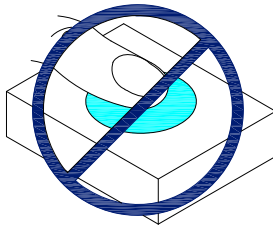

3. Do not stack together assembled PCBs containing exposed LEDs. Impact may scratch the silicone lens or damage the internal circuitry.

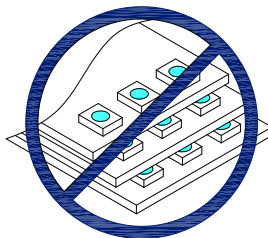

- 4.1. The inner diameter of the SMD pickup nozzle should not exceed the size of the LED to prevent air leaks.
- 4.2. A pliable material is suggested for the nozzle tip to avoid scratching or damaging the LED surface during pickup.
- 4.3. The dimensions of the component must be accurately programmed in the pick-and-place machine to insure precise pickup and avoid damage during production.

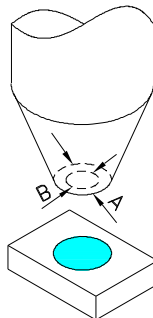

5. As silicone encapsulation is permeable to gases, some corrosive substances such as  $H_2S$  might corrode silver plating of leadframe. Special care should be taken if an LED with silicone encapsulation is to be used near such substances.

## Selection Guide

| Part No.            | Emitting Color (Material) | Lens Type   | Iv (mcd) [2]<br>@ 2mA |      | Viewing<br>Angle [1] |
|---------------------|---------------------------|-------------|-----------------------|------|----------------------|
|                     |                           |             | Min.                  | Typ. | 2θ1/2                |
| AAAF3529LSEEZGKQBKS | Hyper Red (AlGaInP)       | Water Clear | 10                    | 20   | 120°                 |
|                     | Green (InGaN)             |             | 80                    | 180  |                      |
|                     | Blue (InGaN)              |             | 12                    | 30   |                      |

Notes:

1. θ1/2 is the angle from optical centerline where the luminous intensity is 1/2 of the optical peak value.
2. Luminous intensity / luminous Flux: +/-15%.
3. Luminous intensity value is traceable to the CIE127-2007 compliant national standards.

## Electrical / Optical Characteristics at TA=25°C

| Symbol | Parameter                | Emitting Color             | Typ.                | Max.              | Units | Test Conditions |
|--------|--------------------------|----------------------------|---------------------|-------------------|-------|-----------------|
| λpeak  | Peak Wavelength          | Hyper Red<br>Green<br>Blue | 630<br>515<br>460   |                   | nm    | If=2mA          |
| λD [1] | Dominant Wavelength      | Hyper Red<br>Green<br>Blue | 621<br>525<br>465   |                   | nm    | If=2mA          |
| Δλ1/2  | Spectral Line Half-width | Hyper Red<br>Green<br>Blue | 20<br>35<br>25      |                   | nm    | If=2mA          |
| C      | Capacitance              | Hyper Red<br>Green<br>Blue | 25<br>45<br>100     |                   | pF    | Vf=0V;f=1MHz    |
| Vf [2] | Forward Voltage          | Hyper Red<br>Green<br>Blue | 1.8<br>2.65<br>2.65 | 2.1<br>3.1<br>3.1 | V     | If=2mA          |
| Ir     | Reverse Current          | Hyper Red<br>Green<br>Blue |                     | 10<br>50<br>50    | uA    | VR=5V           |

Notes:

- 1.Wavelength: +/-1nm.
- 2.Forward Voltage: +/-0.1V.
- 3.Wavelength value is traceable to the CIE127-2007 compliant national standards.
- 4.Excess driving current and/or operating temperature higher than recommended conditions may result in severe light degradation or premature failure.

## Absolute Maximum Ratings at TA=25°C

| Parameter                               | Hyper Red      | Green | Blue | Units |
|---|----------------|-------|------|-------|
| Power dissipation                       | 105            | 93    | 93   | mW    |
| DC Forward Current                      | 50             | 30    | 30   | mA    |
| Peak Forward Current [1]                | 195            | 150   | 150  | mA    |
| Electrostatic Discharge Threshold (HBM) | -              | 450   | 250  | V     |
| Reverse Voltage                         | 5              |       |      | V     |
| Operating Temperature                   | -40°C To +85°C |       |      |       |
| Storage Temperature                     | -40°C To +85°C |       |      |       |

Notes:

1. 1/10 Duty Cycle, 0.1ms Pulse Width.

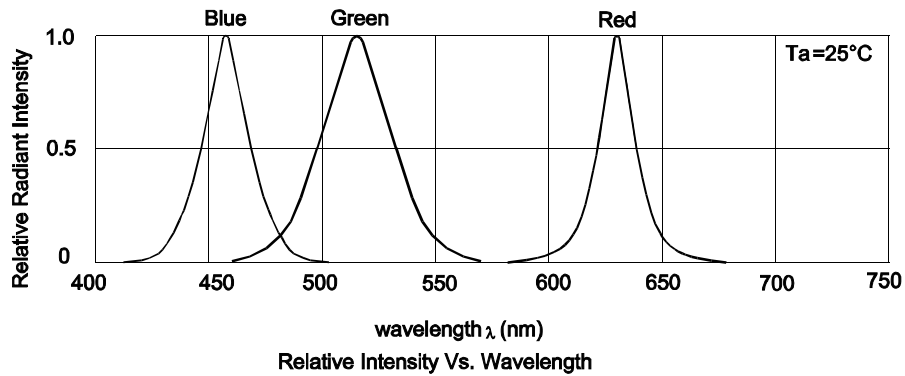

## AAAF3529LSEEZGKBKS Hyper Red

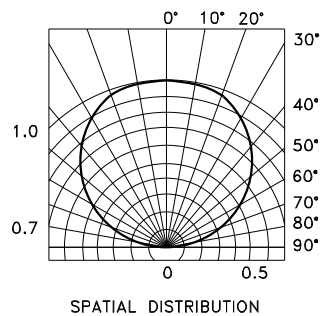
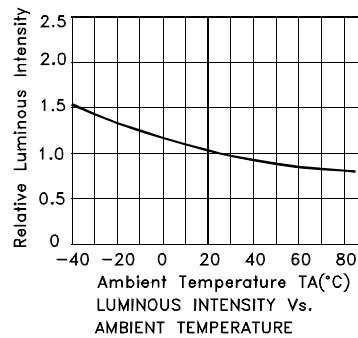
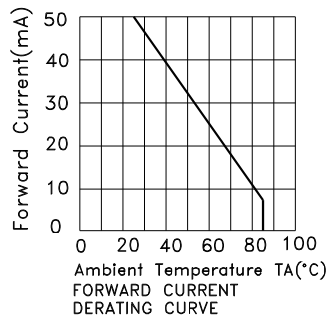
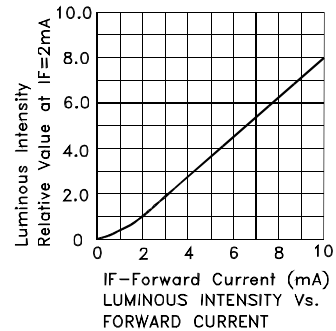
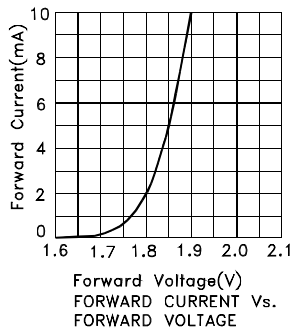

## Green

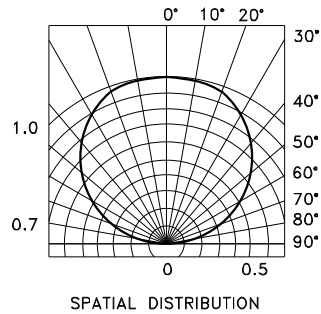
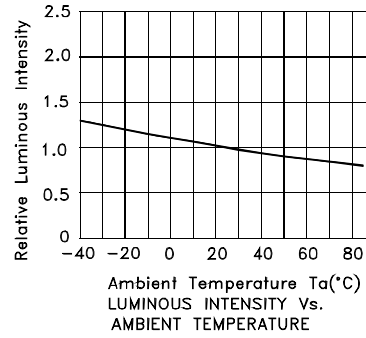
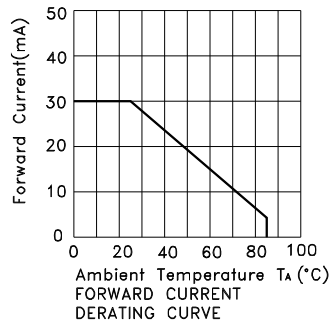
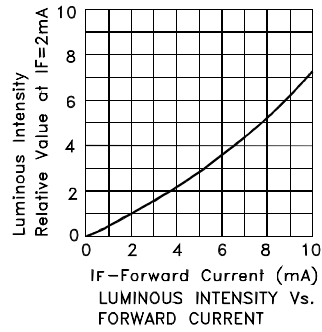
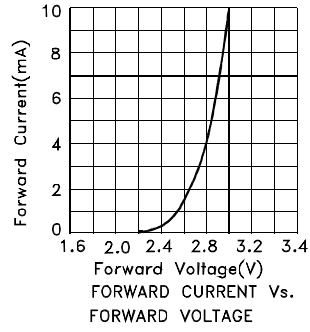

## Blue

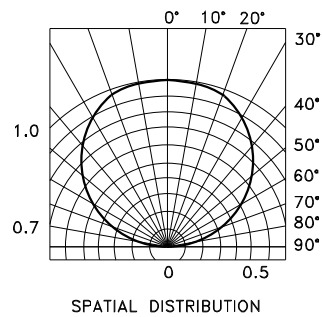
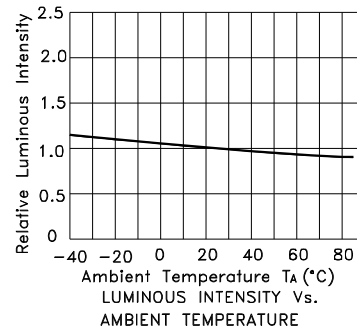
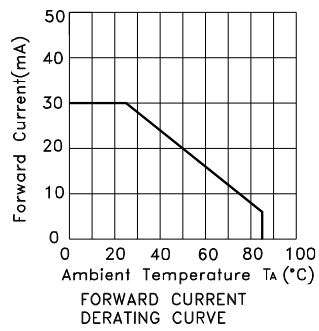
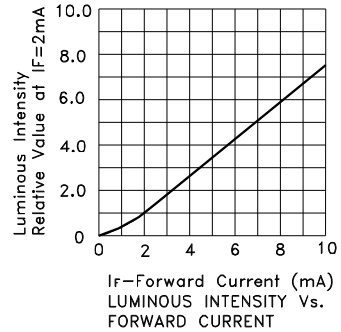
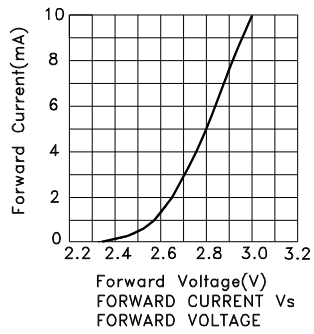

## AAAF3529LSEEZGKBKS

Reflow soldering is recommended and the soldering profile is shown below.  
Other soldering methods are not recommended as they might cause damage to the product.

Reflow Soldering Profile For Lead-free SMT Process.

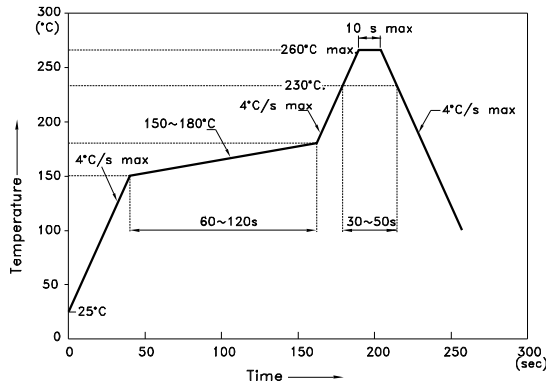

NOTES:

1. We recommend the reflow temperature 245°C(+/-5°C). The maximum soldering temperature should be limited to 260°C.
2. Don't cause stress to the epoxy resin while it is exposed to high temperature.
3. Number of reflow process shall be 2 times or less.

### Recommended Soldering Pattern (Units : mm; Tolerance: ± 0.1)

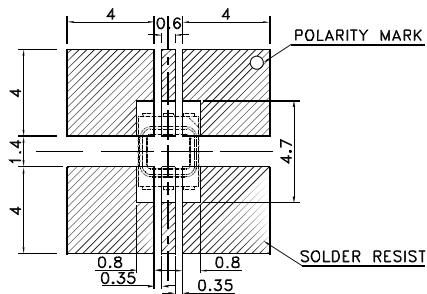

### Reel Dimension

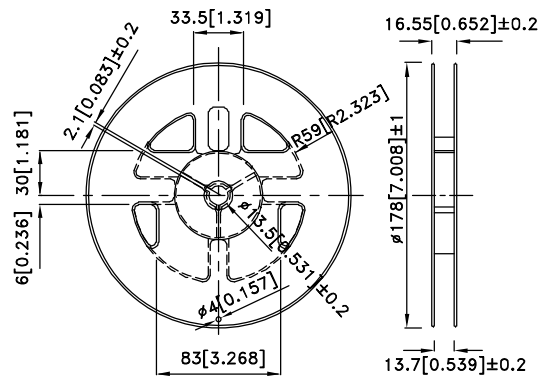

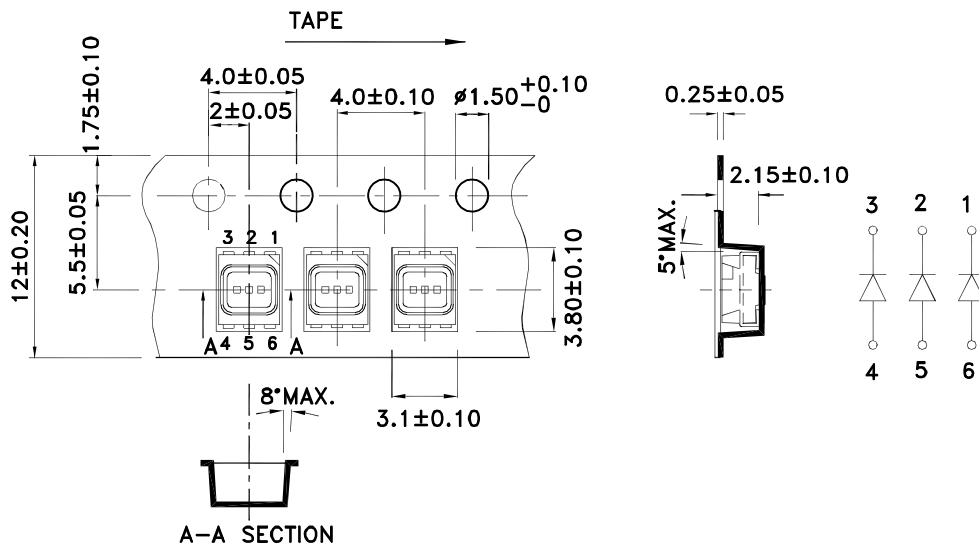

### Tape Dimensions (Units : mm)

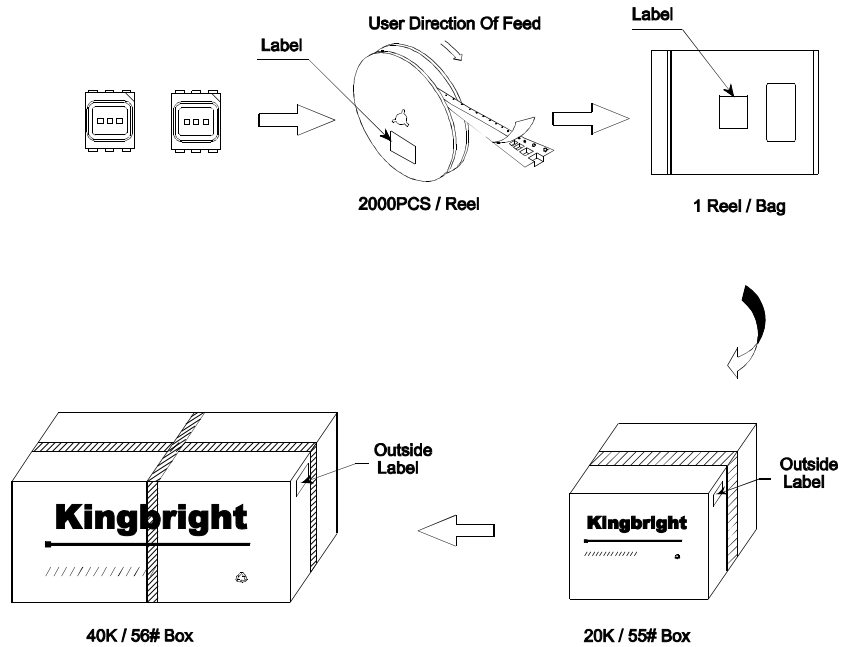

## PACKING & LABEL SPECIFICATIONS

AAAF3529LSEEZGKBKS



|  |      |                           |
|--|------|---------------------------|
| <b>Kingbright</b>  |      |                           |
| P/NO: AAAF3529xxx  |      |                           |
| QTY: 2000 PCS  | Q.C. | Q.C.<br>xxxxxxx<br>PASSED |
| S/N: XXXX  |      |                           |
| CODE: XXX  |      |                           |
| LOT NO:  |      |                           |
|  |      |                           |
| RoHS Compliant   |      |                           |

### Terms and conditions for the usage of this document

1. The information included in this document reflects representative usage scenarios and is intended for technical reference only.
2. The part number, type, and specifications mentioned in this document are subject to future change and improvement without notice. Before production usage customer should refer to the latest datasheet for the updated specifications.
3. When using the products referenced in this document, please make sure the product is being operated within the environmental and electrical limits specified in the datasheet. If customer usage exceeds the specified limits, Kingbright will not be responsible for any subsequent issues.
4. The information in this document applies to typical usage in consumer electronics applications. If customer's application has special reliability requirements or have life-threatening liabilities, such as automotive or medical usage, please consult with Kingbright representative for further assistance.
5. The contents and information of this document may not be reproduced or re-transmitted without permission by Kingbright.
6. All design applications should refer to Kingbright application notes available at <http://www.KingbrightUSA.com/ApplicationNotes>



Компания «Океан Электроники» предлагает заключение долгосрочных отношений при поставках импортных электронных компонентов на взаимовыгодных условиях!

Наши преимущества:

- Поставка оригинальных импортных электронных компонентов напрямую с производств Америки, Европы и Азии, а так же с крупнейших складов мира;
- Широкая линейка поставок активных и пассивных импортных электронных компонентов (более 30 млн. наименований);
- Поставка сложных, дефицитных, либо снятых с производства позиций;
- Оперативные сроки поставки под заказ (от 5 рабочих дней);
- Экспресс доставка в любую точку России;
- Помощь Конструкторского Отдела и консультации квалифицированных инженеров;
- Техническая поддержка проекта, помощь в подборе аналогов, поставка прототипов;
- Поставка электронных компонентов под контролем ВП;
- Система менеджмента качества сертифицирована по Международному стандарту ISO 9001;
- При необходимости вся продукция военного и аэрокосмического назначения проходит испытания и сертификацию в лаборатории (по согласованию с заказчиком);
- Поставка специализированных компонентов военного и аэрокосмического уровня качества (Xilinx, Altera, Analog Devices, Intersil, Interpoint, Microsemi, Actel, Aeroflex, Peregrine, VPT, Syfer, Eurofarad, Texas Instruments, MS Kennedy, Miteq, Cobham, E2V, MA-COM, Hittite, Mini-Circuits, General Dynamics и др.);

Компания «Океан Электроники» является официальным дистрибьютором и эксклюзивным представителем в России одного из крупнейших производителей разъемов военного и аэрокосмического назначения «JONHON», а так же официальным дистрибьютором и эксклюзивным представителем в России производителя высокотехнологичных и надежных решений для передачи СВЧ сигналов «FORSTAR».



## JONHON

«JONHON» (основан в 1970 г.)

Разъемы специального, военного и аэрокосмического назначения:

(Применяются в военной, авиационной, аэрокосмической, морской, железнодорожной, горно- и нефтедобывающей отраслях промышленности)

«FORSTAR» (основан в 1998 г.)

ВЧ соединители, коаксиальные кабели, кабельные сборки и микроволновые компоненты:

(Применяются в телекоммуникациях гражданского и специального назначения, в средствах связи, РЛС, а так же военной, авиационной и аэрокосмической отраслях промышленности).



Телефон: 8 (812) 309-75-97 (многоканальный)

Факс: 8 (812) 320-03-32

Электронная почта: [ocean@oceanchips.ru](mailto:ocean@oceanchips.ru)

Web: <http://oceanchips.ru/>

Адрес: 198099, г. Санкт-Петербург, ул. Калинина, д. 2, корп. 4, лит. А