

AIT-II CONNECTOR

0.64 terminal

Board-to-wire/Wire-to-wire

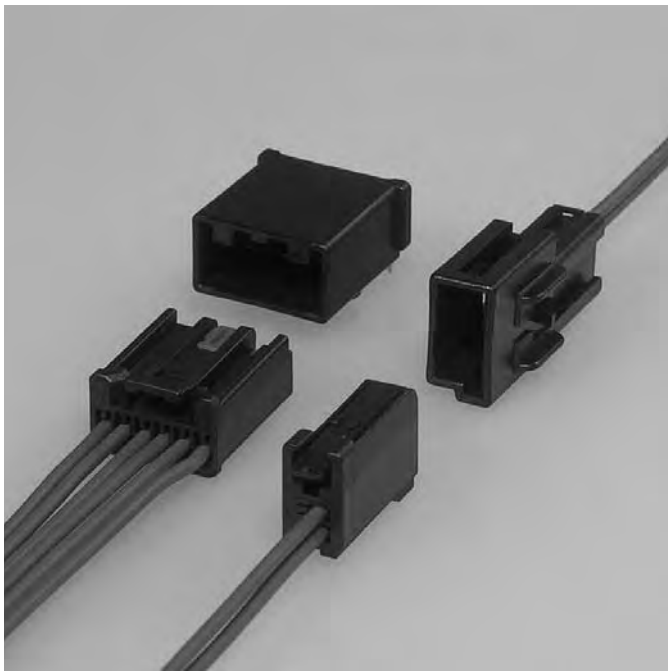

0.64 unsealed low-profile connector series for use in a wide range of automotive applications.

Features

● Ultra Low Profile Connector

Over 30% Height Reduction as compared to the Standard USCAR Footprints.

● Variations

There are multiple varieties of AIT-II Connectors which can satisfy your needs.

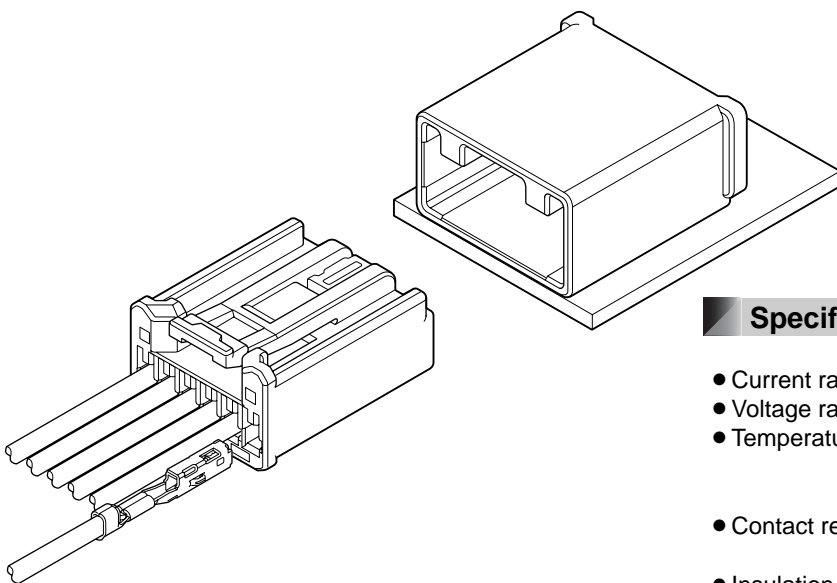

Specifications

- Current rating: 5 A DC max.
- Voltage rating: 14 V DC
- Temperature range: -40°C to +105°C
(including temperature rise in applying electrical current)
- Contact resistance: Initial value/ 15 mΩ max.
After environmental tests/ 15 mΩ max.
- Insulation resistance: 100 MΩ min.
- Applicable wire: SAE/ AVSS/ CAVS/ FLRY
0.3 mm² to 0.85 mm²

- * Compliant with ELV/RoHS.
- * Contact JST for details.

Female terminal

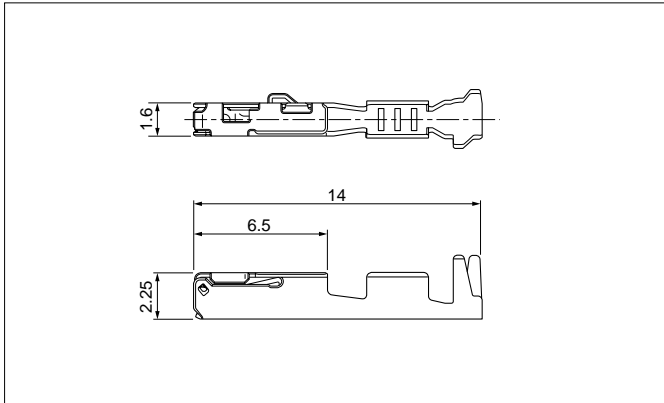

Model No.	Applicable wire range		Q'ty/reel
	Conductor (mm ²)	Insulation O.D. (mm)	
①SAIT-A03T-M064	0.3 to 0.5	≤1.9	6,500
①SAIT-A02T-M064	0.75 to 0.85	≤1.9	6,500
②SAIT-A03GF-M064	0.3 to 0.5	≤1.9	6,500
②SAIT-A02GF-M064	0.75 to 0.85	≤1.9	6,500

Material and Finish

- ① Copper alloy, tin-plated (reflow treatment)
- ② Copper alloy, nickel-undercoated,
Contact area; gold-plated
Barrel area; tin-plated

Female connector (Single row)

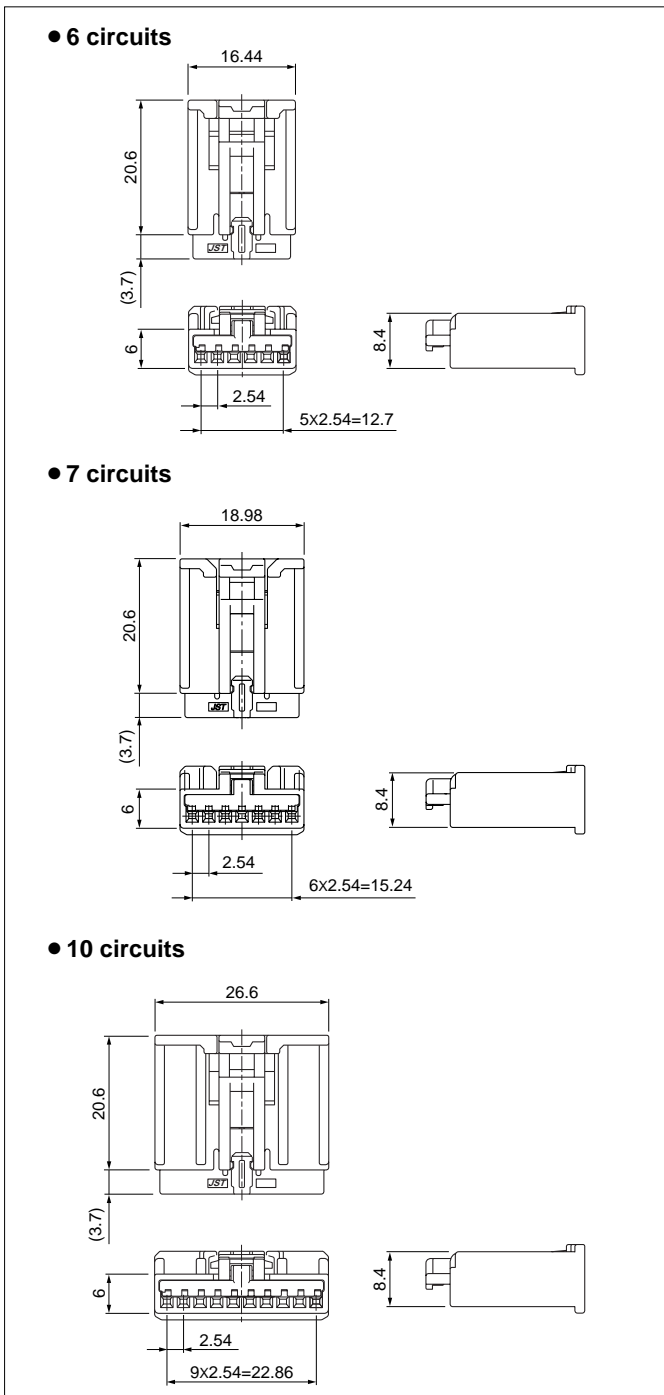

Circuits	Model No.	Q'ty/box	Housing Color
6	AIT2PB-06-1AK	5,250	Black
	AIT2PB-06-1BH	5,250	Gray
	AIT2PB-06-1FS	5,250	Natural (White)
7	AIT2PB-07-1BH	300	Gray
	AIT2PB-07-1FS	300	Natural (White)
10	AIT2PB-10-1AK	3,000	Black
	AIT2PB-10-1BH	3,000	Gray
	AIT2PB-10-1DM	3,000	Green
	AIT2PB-10-1FS	3,000	Natural (White)
	AIT2PB-10-1AD	3,000	Orange

Material and Finish

- Housing: Glass-filled PBT
- TPA: Glass-filled PBT, Red

AIT-II CONNECTOR

Female connector (Dual row)

• 10 circuits

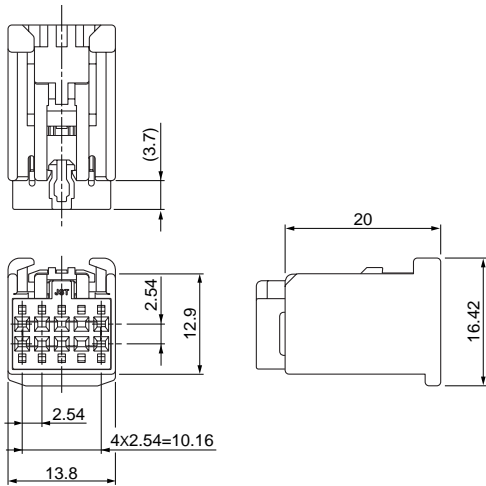

• 18 circuits

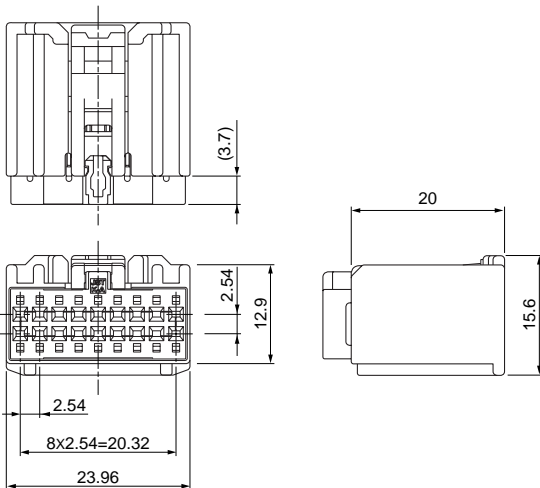

• 22 circuits

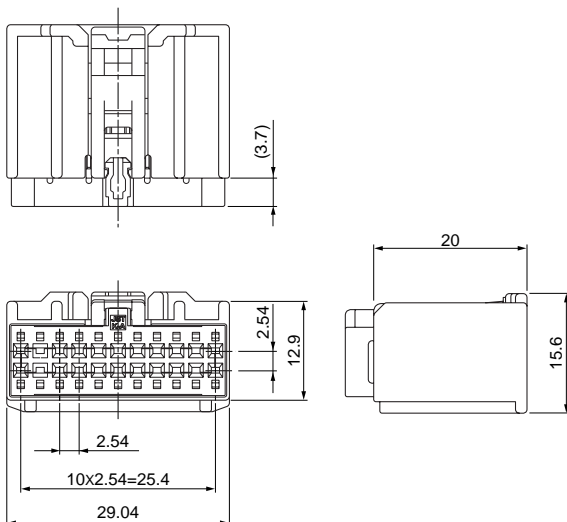

Circuits	Model No.	Q'ty/box	Housing Color	TPA Color
10	AIT2PB-10P-2AK	200	Black	Natural (White)
	AIT2PB-10P-2BH	200	Gray	Natural (White)
18	AIT2PB-18-2AD	120	Orange	Black
	AIT2PB-18-2BD	120	Orange	Natural (White)
	AIT2PB-18-2AK	120	Black	Natural (White)
	AIT2PB-18-2BH	120	Gray	Natural (White)
	AIT2PB-18-2DM	120	Green	Natural (White)
	AIT2PB-18-2FS	120	Natural (White)	Black
22	AIT2PB-22-2AK	100	Black	Natural (White)
	AIT2PB-22-2BH	100	Gray	Natural (White)
	AIT2PB-22-2CN	100	Brown	Natural (White)
	AIT2PB-22-2FS	100	Natural (White)	Black

Material and Finish

Housing: Glass-filled PBT
TPA: Glass-filled PBT

Female connector (Side Lock)

Side-Load TPA

● 3 circuits

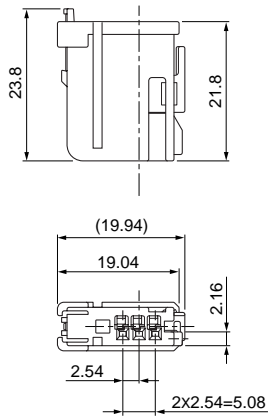

● 4 circuits

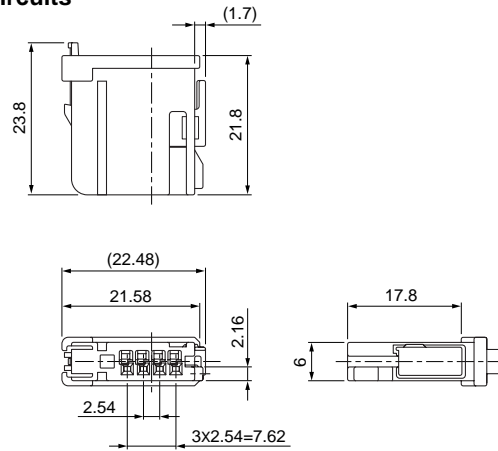

Front-Load TPA

● 2 circuits

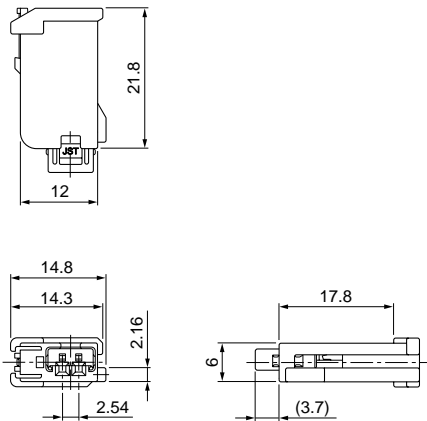

● 4 circuits

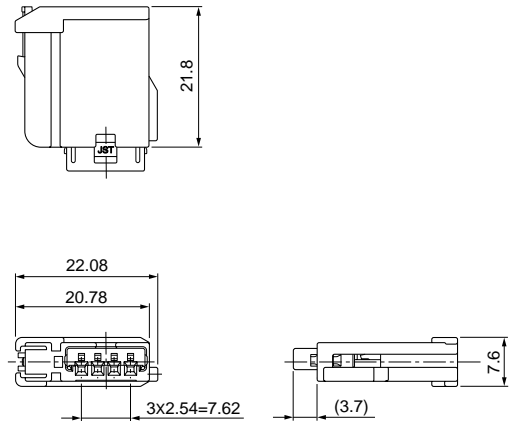

Circuits	TPA Location	Model No.	Q'ty/box	Housing Color
2	Front-Load	AIT2PB-02G-1AK	8,400	Black
		AIT2PB-02A-1FS	8,400	Natural (White)
3	Side-Load	AIT2PB-03B-1AK	6,000	Black
4	Front-Load	AIT2PB-04G-1AK	5,500	Black
	Side-Load	AIT2PB-04B-1AK	400	Black

Material and Finish

Housing: Glass-filled PBT
TPA: Glass-filled PBT, Red

AIT-II CONNECTOR

Male terminal

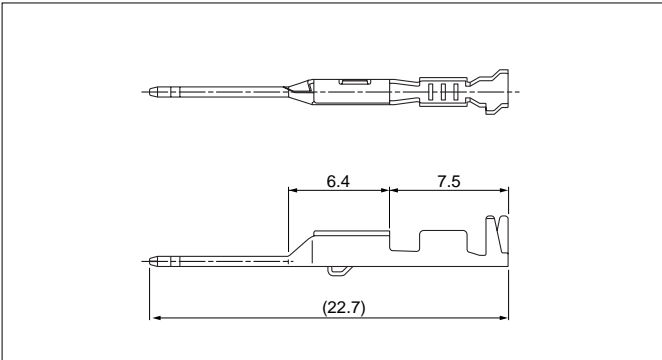

Model No.	Applicable wire range		Q'ty/reel
	Conductor (mm ²)	Insulation O.D. (mm)	
①SAITW-A03T-064	0.3 to 0.5	≤1.9	9,000
①SAITW-A02T-064	0.75 to 0.85	≤1.9	7,000
②SAITW-A03GF-064	0.3 to 0.5	≤1.9	9,000
②SAITW-A02GF-064	0.75 to 0.85	≤1.9	7,000

Material and Finish

- ①Brass, tin-plated (reflow treatment)
- ②Brass, nickel-undercoated, Contact area: gold-plated
Barrel area: tin-plated

Male connector (Top entry type)

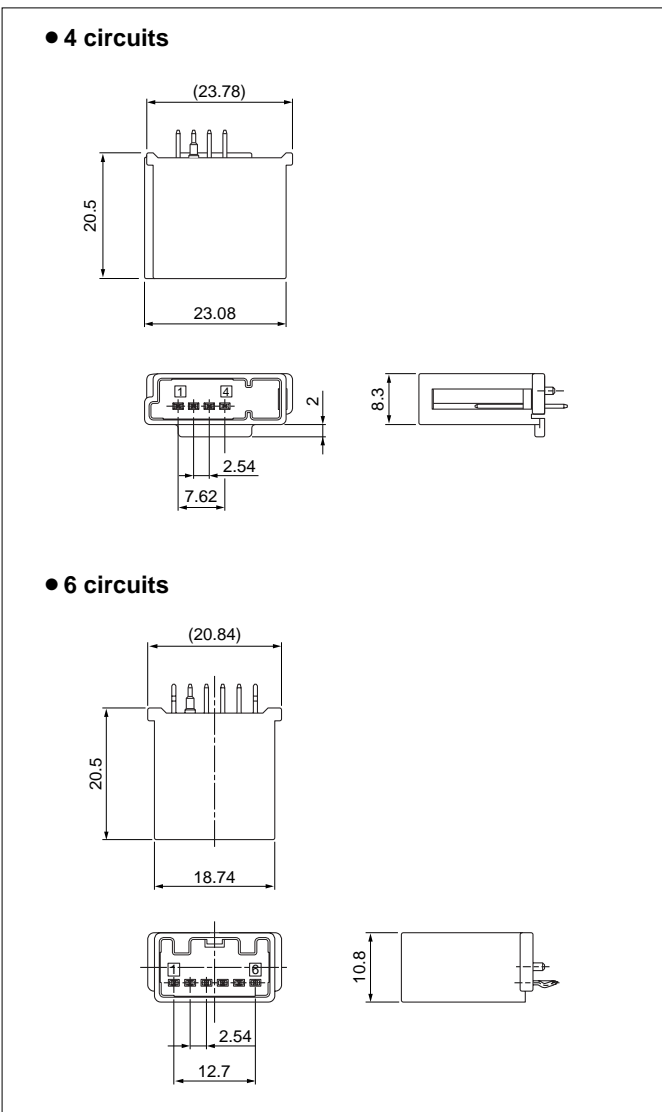

Circuits	Model No.	Q'ty/box	Housing Color
4	①B04BA-AIT2-1AK	108	Black
6	②B06BA-AIT2-1AK-K	120	Black

Material and Finish

- Housing: ①Glass-filled nylon
②Glass-filled PBT
- Pin: Brass, tin-plated

Male connector (Side entry type)

Single row

• 2 circuits

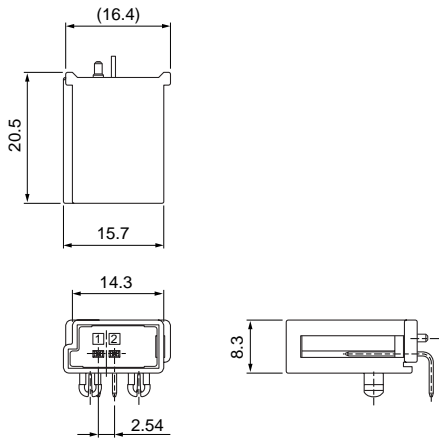

• 6 circuits

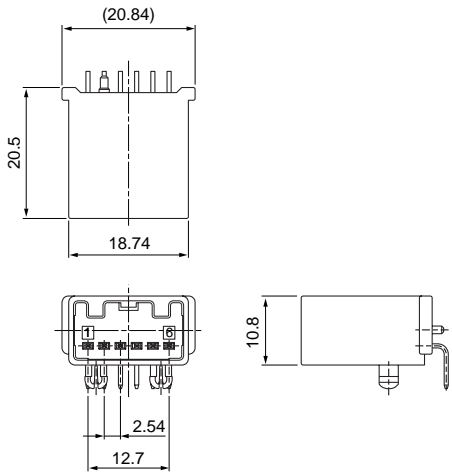

• 10 circuits

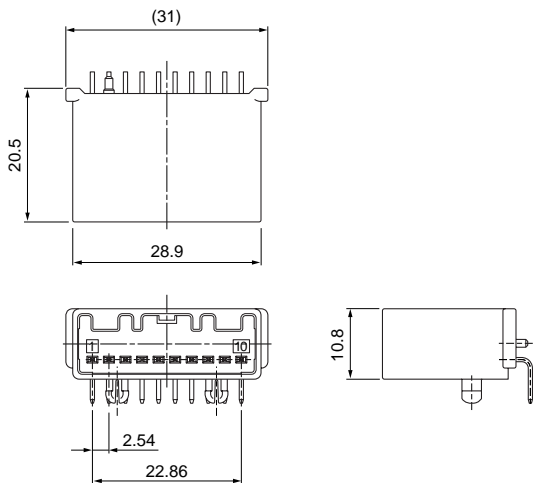

Circuits	Model No.	Q'ty/box	Housing Color
2	① S02BA-AIT2-1AK	96	Black
	① S02BA-AIT2-1FS		Natural (White)
6	① S06B-AIT2-1AK	80	Black
	① S06B-AIT2-1FS		Natural (White)
	① S06B1-AIT2-1FS		Natural (White)
	② S06B1-AIT2G-1AK		Black
10	② S10B-AIT2G-1AK	72	Black
	② S10B-AIT2G-1AD		Orange

Material and Finish

Housing: Glass-filled PBT

Pin: ① Brass, tin-plated

② Brass, tin-plated, nickel-undercoated,

Contact area: gold-plated

AIT-II CONNECTOR

Male connector (Side entry type)

Dual row

• 10 circuits

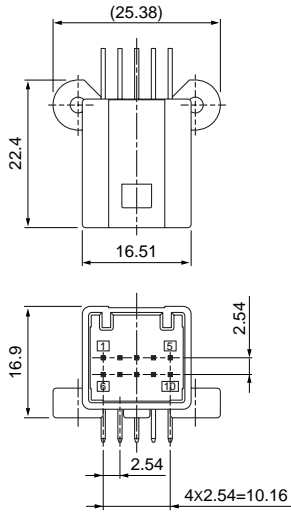

• 18 circuits

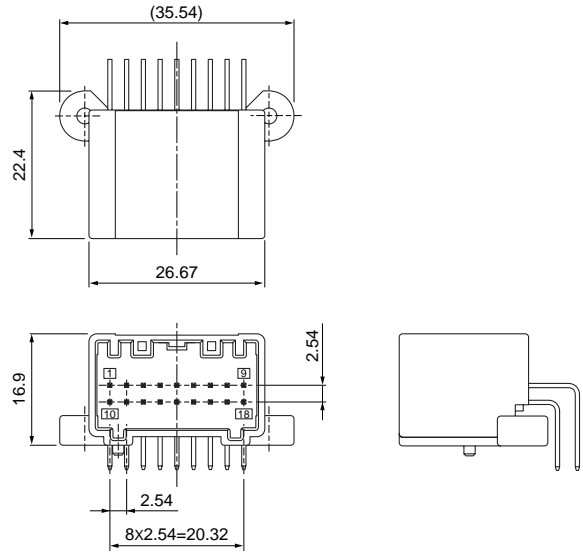

• 20 circuits

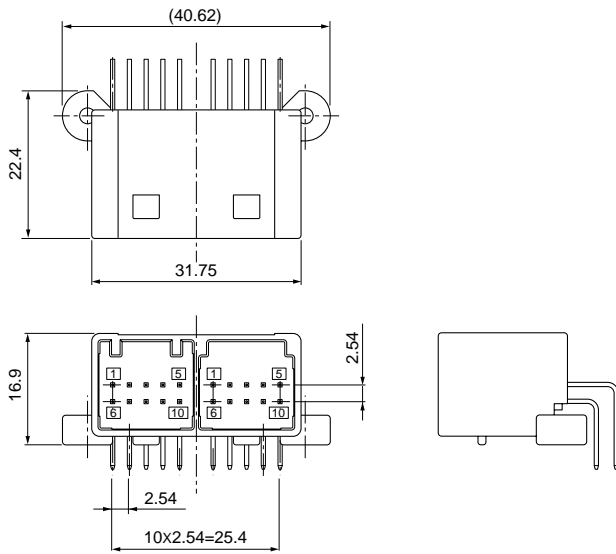

• 22 circuits

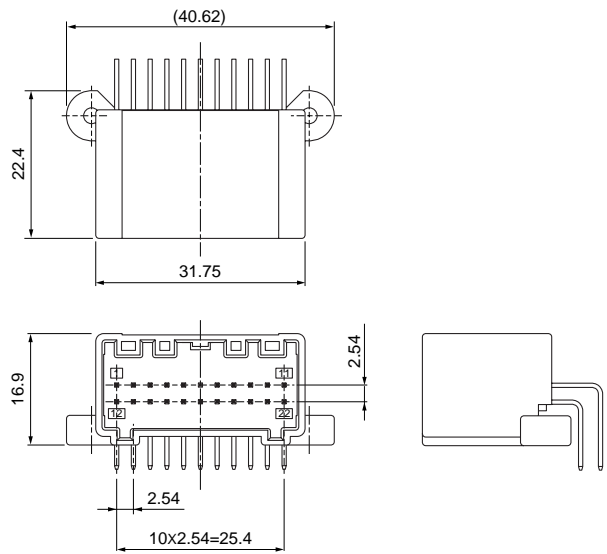

Circuits	Model No.	Q'ty/box	Housing Color
10	① S10B-AIT2-2AK (LF)(SN)	224	Black
	② S10B-AIT2G-2AK		Black
18	② S18B-AIT2G-2AK	160	Gray
	② S18B-AIT2G-2BH		Green
	② S18B-AIT2G-2DM		Natural (White)
	② S18B-AIT2G-2FS		Orange
	② S18B-AIT2G-2AD		Orange
20	② S20B-AIT2G-2A2BK	128	Black
	② S22B-AIT2G-2AK		Black
22	② S22B-AIT2G-2BH	128	Gray
	② S22B-AIT2G-2CN		Brown
	② S22B-AIT2G-2FS		Natural (White)

Material and Finish

Housing: Glass-filled PBT

Pin: ① Brass, tin-plated

② Brass, tin-plated, Contact area: gold-plated

Male connector (Wire-to-wire)

• 2 circuits

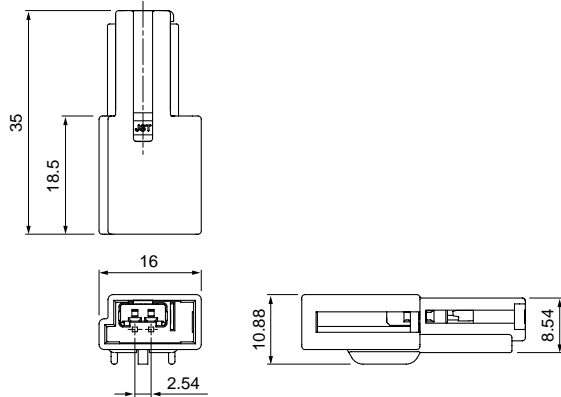

• 3 circuits

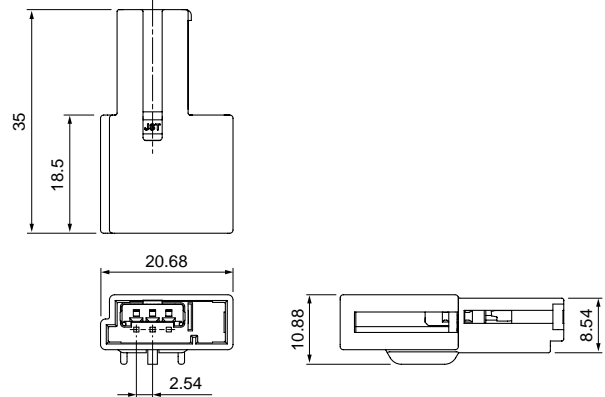

• 6 circuits

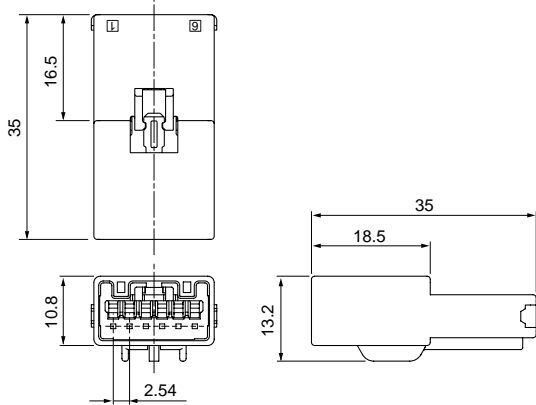

• 7 circuits

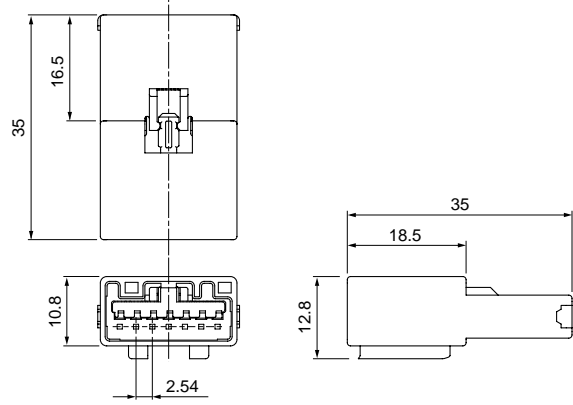

• 10 circuits (Dual row)

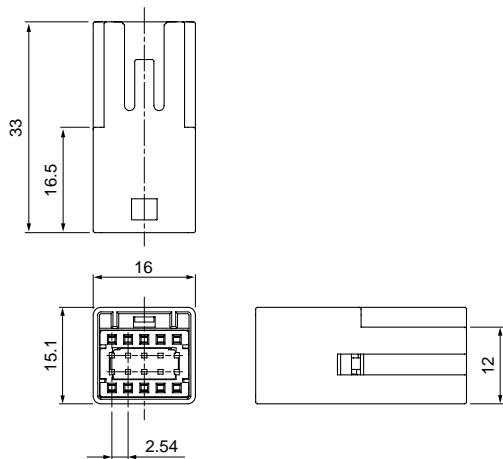

• 22 circuits (Dual row)

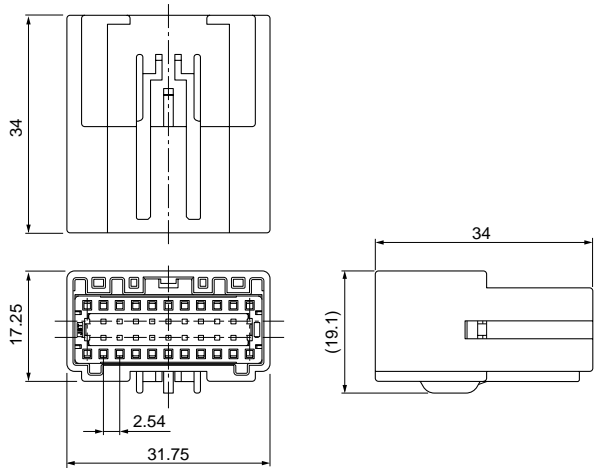

Circuits	Model No.	Q'ty/box	Housing Color	TPA Color
2	AIT2WSB-02A-1AK	300	Black	Red
3	AIT2WSB-03A-1AK	200	Black	Red
6	AIT2WSB-06-1AK	150	Black	Red
	AIT2WSB-06-1FS	150	Natural (White)	Red
7	AIT2WSB-07-1FS	150	Natural (White)	Red
	AIT2WSB-07-1FK	150	Black	Red
10	AIT2WSB-10A-2AK	150	Black	Natural (White)
	AIT2WSB-10A-2BH	150	Gray	Natural (White)
22	AIT2WSB-22-2AK	60	Black	Natural

Material

Housing: Glass-filled PBT
TPA: Glass-filled PBT

PC board layout, Assembly layout

Top entry type

● 4 circuits

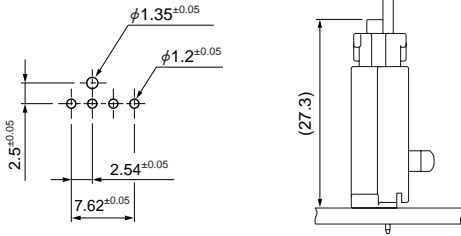

● 6 circuits

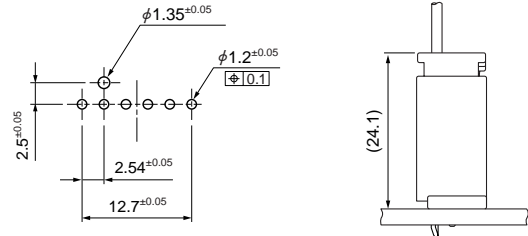

Side entry type

Single row

● 2 circuits

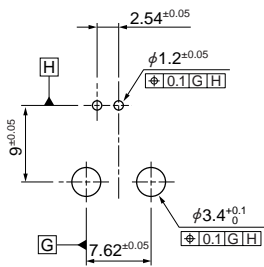

● 6 circuits

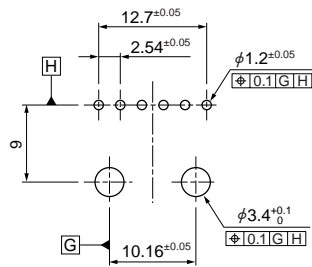

● 10 circuits

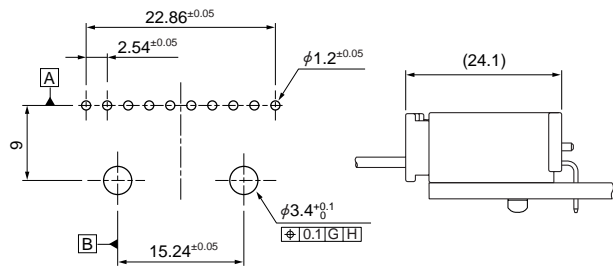

Dual row

● 10 circuits

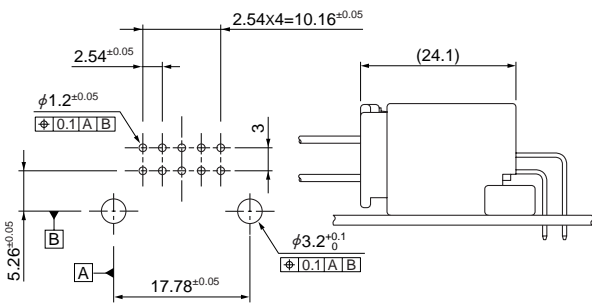

● 20 circuits

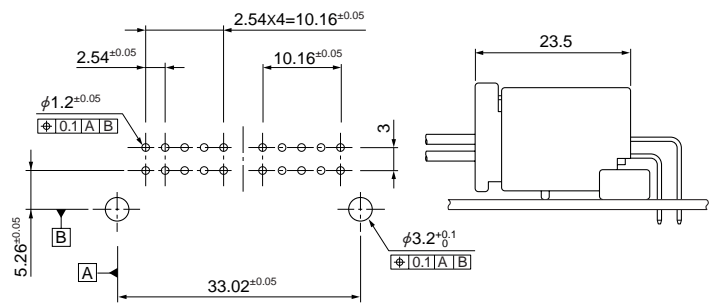

● 18 circuits

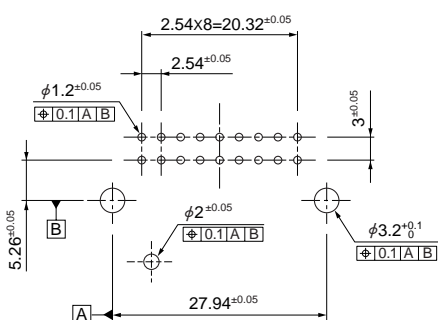

● 22 circuits

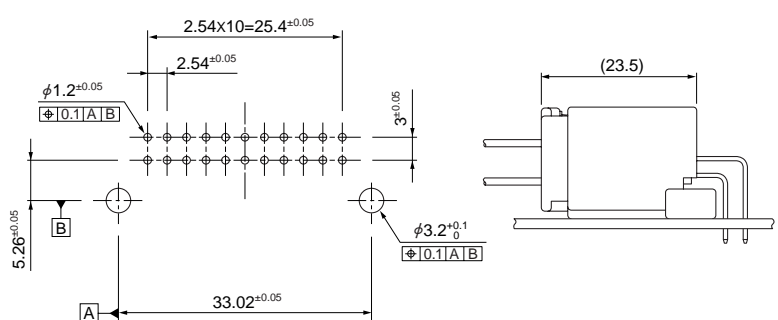

Note: 1. Tolerances are non-cumulative.

2. Hole dimensions differ according to the type of PC board and piercing method. The dimensions above should serve as guideline. Contact JST for details.

Assembly layout

Wire-to-wire type

• Single row

AIT2WSB-()-1()

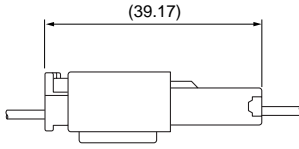

AIT2WSB-()A-1()

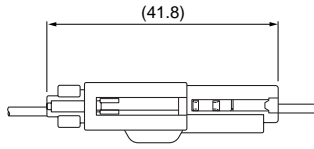

• Dual row

AIT2WSB-()A-2()

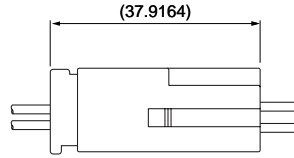

AIT2WSB-22-2AK

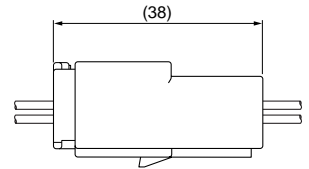

Crimping machine, Applicator

Strip terminal	Crimping machine	Crimp applicator MKS-L	
		Dies	Crimp applicator with dies
SAIT-A03()-M064	AP-K2N	MK/SAIT-A03-064	APLMK SAIT-A03-064
SAIT-A02()-M064		MK/SAIT-A02-064	APLMK SAIT-A02-064
SAITW-A03()-064		MK/SAITW-A03-064	APLMK SAITW-A03-064
SAITW-A02()-064		MK/SAITW-A02-064	APLMK SAITW-A02-064

Note: When crimping operation is conducted using an applicator and die set other than the above, JST cannot guarantee the performance of the terminal.

Mouser Electronics

Authorized Distributor

Click to View Pricing, Inventory, Delivery & Lifecycle Information:

JST:

[S22B-AIT2G-2AK](#)

Компания «Океан Электроники» предлагает заключение долгосрочных отношений при поставках импортных электронных компонентов на взаимовыгодных условиях!

Наши преимущества:

- Поставка оригинальных импортных электронных компонентов напрямую с производств Америки, Европы и Азии, а так же с крупнейших складов мира;
- Широкая линейка поставок активных и пассивных импортных электронных компонентов (более 30 млн. наименований);
- Поставка сложных, дефицитных, либо снятых с производства позиций;
- Оперативные сроки поставки под заказ (от 5 рабочих дней);
- Экспресс доставка в любую точку России;
- Помощь Конструкторского Отдела и консультации квалифицированных инженеров;
- Техническая поддержка проекта, помощь в подборе аналогов, поставка прототипов;
- Поставка электронных компонентов под контролем ВП;
- Система менеджмента качества сертифицирована по Международному стандарту ISO 9001;
- При необходимости вся продукция военного и аэрокосмического назначения проходит испытания и сертификацию в лаборатории (по согласованию с заказчиком);
- Поставка специализированных компонентов военного и аэрокосмического уровня качества (Xilinx, Altera, Analog Devices, Intersil, Interpoint, Microsemi, Actel, Aeroflex, Peregrine, VPT, Syfer, Eurofarad, Texas Instruments, MS Kennedy, Miteq, Cobham, E2V, MA-COM, Hittite, Mini-Circuits, General Dynamics и др.);

Компания «Океан Электроники» является официальным дистрибьютором и эксклюзивным представителем в России одного из крупнейших производителей разъемов военного и аэрокосмического назначения «JONHON», а так же официальным дистрибьютором и эксклюзивным представителем в России производителя высокотехнологичных и надежных решений для передачи СВЧ сигналов «FORSTAR».



JONHON

«JONHON» (основан в 1970 г.)

Разъемы специального, военного и аэрокосмического назначения:

(Применяются в военной, авиационной, аэрокосмической, морской, железнодорожной, горно- и нефтедобывающей отраслях промышленности)

«FORSTAR» (основан в 1998 г.)

ВЧ соединители, коаксиальные кабели, кабельные сборки и микроволновые компоненты:

(Применяются в телекоммуникациях гражданского и специального назначения, в средствах связи, РЛС, а так же военной, авиационной и аэрокосмической отраслях промышленности).



Телефон: 8 (812) 309-75-97 (многоканальный)

Факс: 8 (812) 320-03-32

Электронная почта: ocean@oceanchips.ru

Web: <http://oceanchips.ru/>

Адрес: 198099, г. Санкт-Петербург, ул. Калинина, д. 2, корп. 4, лит. А