



**RO3104C**

- Ideal for 303.825 MHz Transmitters
- Very Low Series Resistance
- Quartz Stability
- Complies with Directive 2002/95/EC (RoHS)



**303.825 MHz  
SAW  
Resonator**

The RO3104C is a true one-port, surface-acoustic-wave (SAW) resonator in a surface-mount, ceramic case. It provides reliable, fundamental-mode, quartz frequency stabilization of local oscillators operating at approximately 303.825 MHz. This SAW was designed for AM transmitters in automotive-keyless-entry applications operating in the USA under FCC Part 15, in Canada under DoC RSS-210, and in Italy.

**Absolute Maximum Ratings**

| Rating   | Value      | Units |
|--|------------|-------|
| Input Power Level                                  | 0          | dBm   |
| DC Voltage   | 12         | VDC   |
| Storage Temperature                                | -40 to +85 | °C    |
| Soldering Temperature (10 seconds / 5 cycles max.) | 260        | °C    |

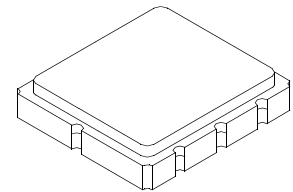

**SM5050-8 Case  
5 X 5**

**Electrical Characteristics**

| Characteristic                                     |                                      | Sym          | Notes      | Minimum            | Typical | Maximum | Units  |  |          |     |
|--|--------------------------------------|--------------|------------|--------------------|---------|---------|--------|--|----------|-----|
| Frequency (+25 °C)                                 | Absolute Frequency                   | $f_C$        | 2, 3, 4, 5 | 303.750            |         | 303.900 | MHz    |  |          |     |
|  | Tolerance from 303.825 MHz           | $\Delta f_C$ |            |                    |         |         |        |  | $\pm 75$ | kHz |
| Insertion Loss                                     |                                      | IL           | 2, 5, 6    |                    | 1.3     | 2.0     | dB     |  |          |     |
| Quality Factor                                     | Unloaded Q                           | $Q_U$        |            |                    | 9800    |         |        |  |          |     |
|  | 50W Loaded Q                         | $Q_L$        |            |                    | 1300    |         |        |  |          |     |
| Temperature Stability                              | Turnover Temperature                 | $T_O$        | 6, 7, 8    | 10                 | 25      | 40      | °C     |  |          |     |
|  | Turnover Frequency                   | $f_O$        |            |                    |         |         |        |  | $f_C$    |     |
|  | Frequency Temperature Coefficient    | FTC          |            |                    |         |         |        |  | 0.032    |     |
| Frequency Aging                                    | Absolute Value during the First Year | $ f_A $      | 1, 6       |                    | 10      |         | ppm/yr |  |          |     |
| DC Insulation Resistance between Any Two Terminals |                                      |              | 5          | 1.0                |         |         | MΩ     |  |          |     |
| RF Equivalent RLC Model                            | Motional Resistance                  | $R_M$        | 5, 7, 9    |                    | 15.6    |         | Ω      |  |          |     |
|  | Motional Inductance                  | $L_M$        |            |                    | 79.7    |         | μH     |  |          |     |
|  | Motional Capacitance                 | $C_M$        |            |                    | 3.4     |         | fF     |  |          |     |
|  | Shunt Static Capacitance             | $C_O$        | 5, 6, 9    |                    | 3.3     |         | pF     |  |          |     |
| Test Fixture Shunt Inductance                      |                                      | $L_{TEST}$   | 2, 7       |                    | 83.9    |         | nH     |  |          |     |
| Lid Symbolization                                  |                                      |              |            | 688 // YWWS        |         |         |        |  |          |     |
| Standard Reel Quantity                             | Reel Size 7 Inch                     |              |            | 500 Pieces / Reel  |         |         |        |  |          |     |
|  | Reel Size 13 Inch                    |              |            | 3000 Pieces / Reel |         |         |        |  |          |     |



**CAUTION: Electrostatic Sensitive Device. Observe precautions for handling.**

**Notes:**

1. Frequency aging is the change in  $f_C$  with time and is specified at +65°C or less. Aging may exceed the specification for prolonged temperatures above +65°C. Typically, aging is greatest the first year after manufacture, decreasing in subsequent years.
2. The center frequency,  $f_C$ , is measured at the minimum insertion loss point,  $IL_{MIN}$ , with the resonator in the 50 Ω test system (VSWR ≤ 1.2:1). The shunt inductance,  $L_{TEST}$ , is tuned for parallel resonance with  $C_O$  at  $f_C$ . Typically,  $f_{OSCILLATOR}$  or  $f_{TRANSMITTER}$  is approximately equal to the resonator  $f_C$ .
3. One or more of the following United States patents apply: 4,454,488 and 4,616,197.
4. Typically, equipment utilizing this device requires emissions testing and government approval, which is the responsibility of the equipment manufacturer.
5. Unless noted otherwise, case temperature  $T_C = +25°C \pm 2°C$ .
6. The design, manufacturing process, and specifications of this device are subject to change without notice.
7. Derived mathematically from one or more of the following directly measured parameters:  $f_C$ , IL, 3 dB bandwidth,  $f_C$  versus  $T_C$ , and  $C_O$ .
8. Turnover temperature,  $T_O$ , is the temperature of maximum (or turnover) frequency,  $f_O$ . The nominal frequency at any case temperature,  $T_C$ , may be calculated from:  $f = f_O [1 - FTC (T_O - T_C)^2]$ . Typically *oscillator*  $T_O$  is approximately equal to the specified *resonator*  $T_O$ .
9. This equivalent RLC model approximates resonator performance near the resonant frequency and is provided for reference only. The capacitance  $C_O$  is the static (nonmotional) capacitance between the two terminals measured at low frequency (10 MHz) with a capacitance meter. The measurement includes parasitic capacitance with "NC" pads unconnected. Case parasitic capacitance is approximately 0.05 pF. Transducer parallel capacitance can be calculated as:  $C_P \approx C_O - 0.05 \text{ pF}$ .

## Electrical Connections

The SAW resonator is bidirectional and may be installed with either orientation. The two terminals are interchangeable and unnumbered. The callout NC indicates no internal connection. The NC pads assist with mechanical positioning and stability. External grounding of the NC pads is recommended to help reduce parasitic capacitance in the circuit.

| Pin | Connection |
|-----|------------|
| 1   | NC         |
| 2   | Terminal   |
| 3   | NC         |
| 4   | NC         |
| 5   | NC         |
| 6   | Terminal   |
| 7   | NC         |
| 8   | NC         |

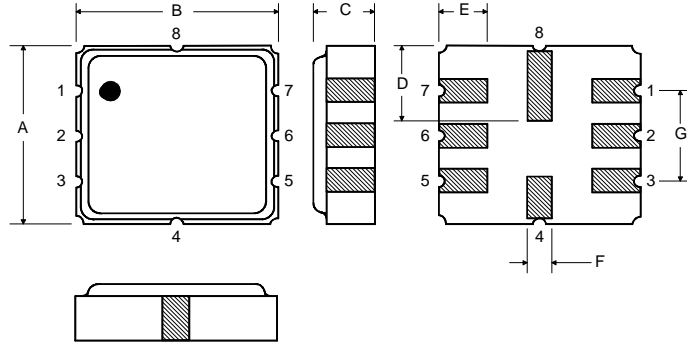

## Case Dimensions

| Dimension | mm   |      |      | Inches |       |       |
|-----------|------|------|------|--------|-------|-------|
|           | Min  | Nom  | Max  | Min    | Nom   | Max   |
| A         | 4.8  | 5.0  | 5.2  | 0.189  | 0.197 | 0.205 |
| B         | 4.8  | 5.0  | 5.2  | 0.189  | 0.197 | 0.205 |
| C         |      |      | 1.7  |        |       | 0.067 |
| D         |      | 2.08 |      |        | 0.082 |       |
| E         |      | 1.17 |      |        | 0.046 |       |
| F         |      | 0.64 |      |        | 0.025 |       |
| G         | 2.39 | 2.54 | 2.69 | 0.094  | 0.100 | 0.106 |

## Typical Test Circuit

The test circuit inductor,  $L_{TEST}$ , is tuned to resonate with the static capacitance,  $C_O$ , at  $F_C$ .

## Electrical Test

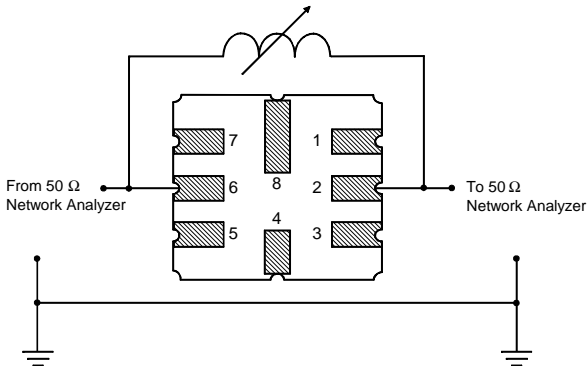

## Power Test

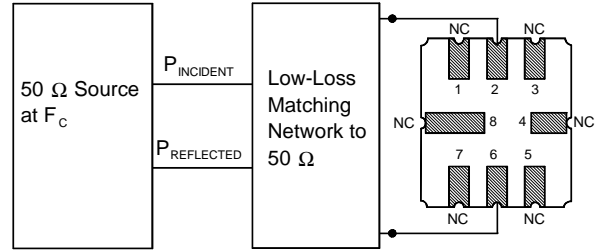

## Typical Application Circuits

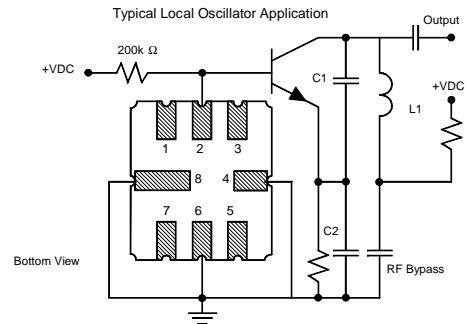
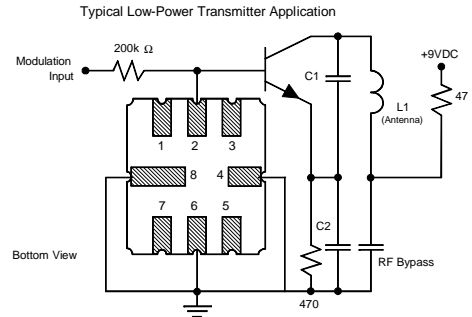

## Equivalent LC Model

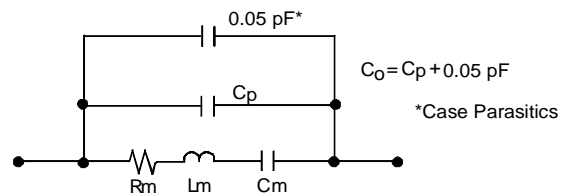

## Temperature Characteristics

The curve shown on the right accounts for resonator contribution only and does not include LC component temperature contributions.

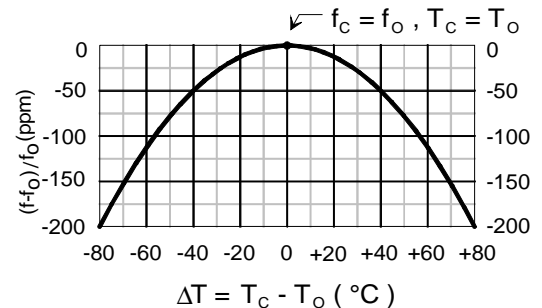

Компания «Океан Электроники» предлагает заключение долгосрочных отношений при поставках импортных электронных компонентов на взаимовыгодных условиях!

Наши преимущества:

- Поставка оригинальных импортных электронных компонентов напрямую с производств Америки, Европы и Азии, а так же с крупнейших складов мира;
- Широкая линейка поставок активных и пассивных импортных электронных компонентов (более 30 млн. наименований);
- Поставка сложных, дефицитных, либо снятых с производства позиций;
- Оперативные сроки поставки под заказ (от 5 рабочих дней);
- Экспресс доставка в любую точку России;
- Помощь Конструкторского Отдела и консультации квалифицированных инженеров;
- Техническая поддержка проекта, помощь в подборе аналогов, поставка прототипов;
- Поставка электронных компонентов под контролем ВП;
- Система менеджмента качества сертифицирована по Международному стандарту ISO 9001;
- При необходимости вся продукция военного и аэрокосмического назначения проходит испытания и сертификацию в лаборатории (по согласованию с заказчиком);
- Поставка специализированных компонентов военного и аэрокосмического уровня качества (Xilinx, Altera, Analog Devices, Intersil, Interpoint, Microsemi, Actel, Aeroflex, Peregrine, VPT, Syfer, Eurofarad, Texas Instruments, MS Kennedy, Miteq, Cobham, E2V, MA-COM, Hittite, Mini-Circuits, General Dynamics и др.);

Компания «Океан Электроники» является официальным дистрибьютором и эксклюзивным представителем в России одного из крупнейших производителей разъемов военного и аэрокосмического назначения «JONHON», а так же официальным дистрибьютором и эксклюзивным представителем в России производителя высокотехнологичных и надежных решений для передачи СВЧ сигналов «FORSTAR».



## JONHON

«JONHON» (основан в 1970 г.)

Разъемы специального, военного и аэрокосмического назначения:

(Применяются в военной, авиационной, аэрокосмической, морской, железнодорожной, горно- и нефтедобывающей отраслях промышленности)

«FORSTAR» (основан в 1998 г.)

ВЧ соединители, коаксиальные кабели, кабельные сборки и микроволновые компоненты:

(Применяются в телекоммуникациях гражданского и специального назначения, в средствах связи, РЛС, а так же военной, авиационной и аэрокосмической отраслях промышленности).



Телефон: 8 (812) 309-75-97 (многоканальный)

Факс: 8 (812) 320-03-32

Электронная почта: [ocean@oceanchips.ru](mailto:ocean@oceanchips.ru)

Web: <http://oceanchips.ru/>

Адрес: 198099, г. Санкт-Петербург, ул. Калинина, д. 2, корп. 4, лит. А