

# IS32LT3126

## 150mA DUAL CHANNEL LED DRIVER WITH FAULT DETECTION

May 2018

### GENERAL DESCRIPTION

The IS32LT3126 is a dual linear programmable current regulator consisting of 2 independently controlled output channels; each channel is capable of sourcing 150mA. Both channels can be combined to provide a total of 300mA. It supports PWM dimming of both channels via power supply modulation (PSM). It also features ENx pins to individually PWM dim and independently adjust the average output current for each channel. The max current for each channel is set with its corresponding external resistor.

The UVx pins set the VCC under voltage lockout of each channel to match the LED stack for high side PWM dimming operation. In addition, the IC integrates fault protection for LED open/short, ISETx pin open/short and over temperature condition for robust operation. Detection of these failures is reported by FAULTB pin. When a fault is detected the device will disable itself and output an open drain low signal. Multiple devices can have their FAULTB pins connected to create a “one-fail-all-fail” condition. For multiple LED string applications, the device can detect a single LED short. The single LED short detection is set by a resistor divider on the STx pins. A single LED short failure is reported by the separate FAULTB\_S pin.

The IS32LT3126 is targeted at the automotive market with end applications to include interior and exterior lighting. For 12V automotive applications the low dropout driver can support one to several LEDs on the output channels. It is offered in a small thermally enhanced eTSSOP-16 package.

### FEATURES

- Dual channel: each channel can source up to 150mA and the two channels combined to source up to 300mA
- External resistors individually set source current
- 4% channel to channel current matching
- Individually programmable VCC under voltage lockout to match the LED stack for PSM operation
- Individual PWM dimming
- Shared fault flag for multiple devices operation
- Fault protection with flag reporting:
  - Single LED short (optional to turn off all LEDs)
  - LED string open/short
  - OUTx pins short to VCC/GND
  - ISETx pins open/short
  - Over temperature current rollback (no reporting)
  - Thermal shutdown
- External C<sub>STOR</sub> capacitor keeps fault status during start/stop operation
- eTSSOP-16 package
- Operating temperature range from -40°C ~ +125°C
- AEC-Q100 qualification

### APPLICATIONS

- Automotive interior/exterior lighting:
  - Turn signal light

### TYPICAL APPLICATION CIRCUIT

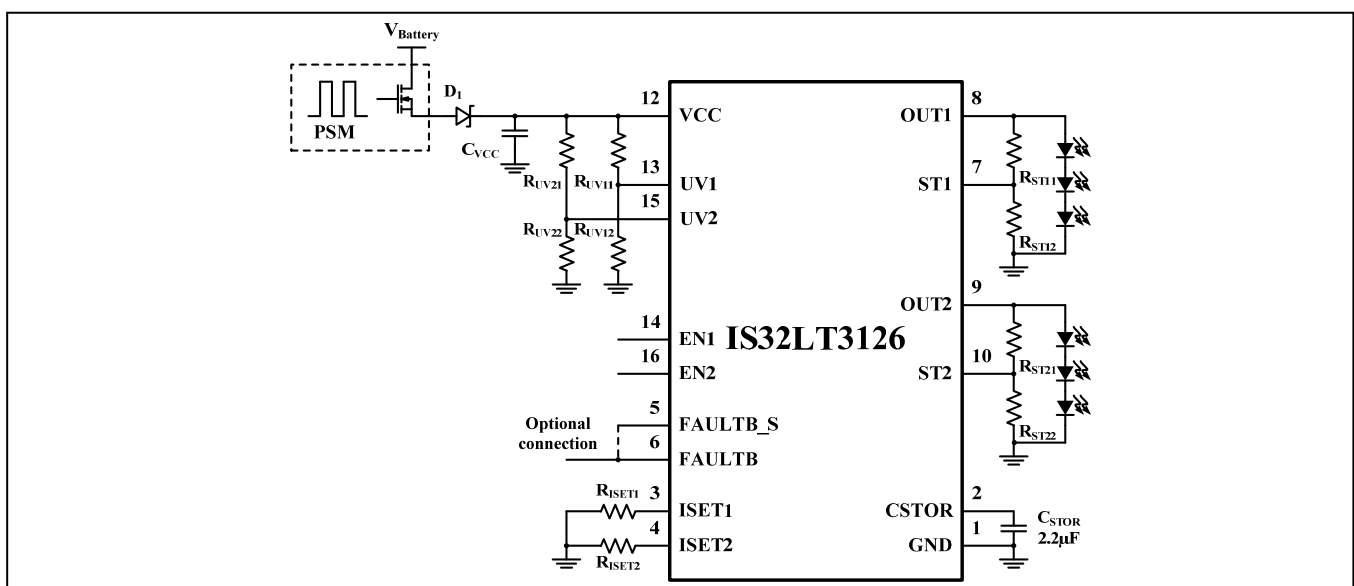
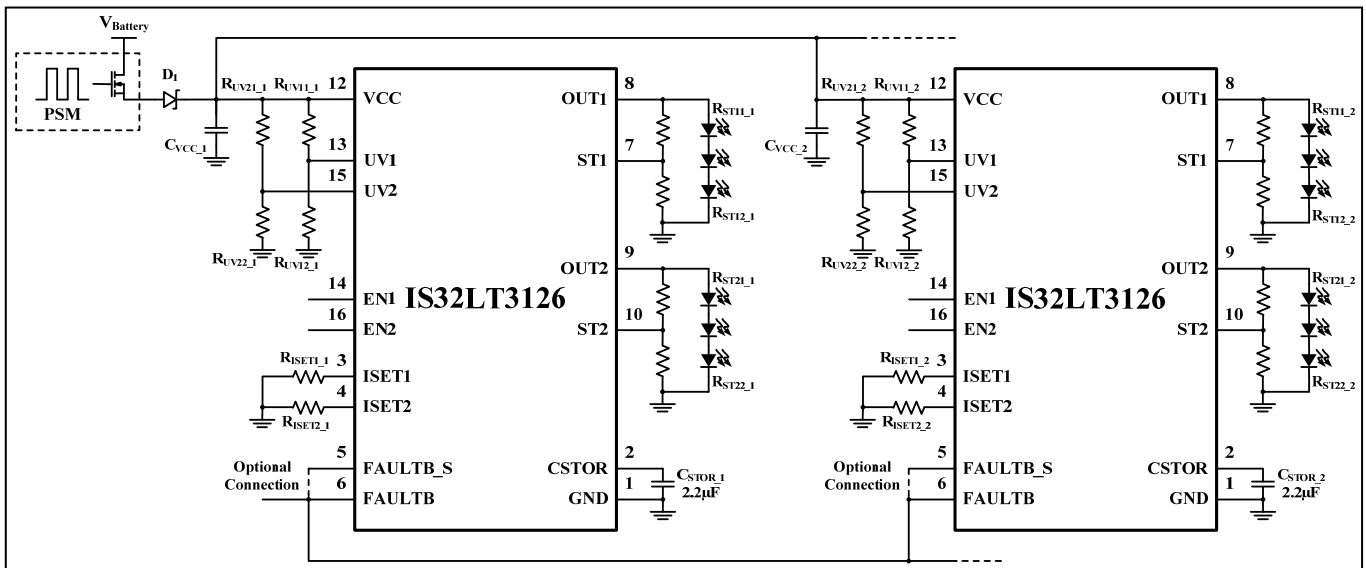

Figure 1 Typical Application Circuit

# IS32LT3126

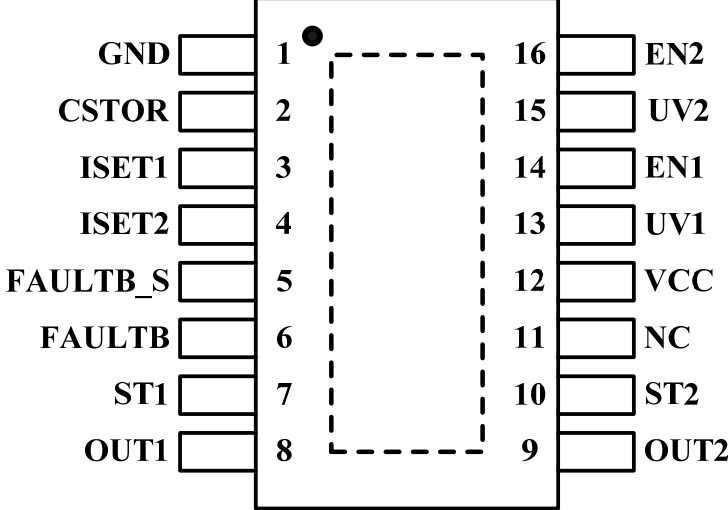

**Figure 2** Typical Application Circuit (Several Devices In Parallel with FAULTB Interlinkage)

**Note 1:** For PSM dimming application, high  $C_{VCC}$  capacitor value will affect the dimming accuracy. To get better dimming performance, recommend  $0.1\mu\text{F}$  for it.

# IS32LT3126

## PIN CONFIGURATION

Package	Pin Configuration (Top View)
eTSSOP-16	

## PIN DESCRIPTION

No.	Pin	Description
1	GND	Ground.
2	CSTOR	Keep-alive capacitor to maintain the deglitch timer and fault latch status with collapsing VCC.
3	ISET1	Output current setting for channel 1. Connect a resistor between this pin and GND to set the maximum output current.
4	ISET2	Output current setting for channel 2. Connect a resistor between this pin and GND to set the maximum output current.
5	FAULTB_S	Open drain fault reporting output with internal pull up to 4.5V. Indicate the fault condition of single LED short.
6	FAULTB	Open drain fault reporting output with internal pull up to 4.5V. Indicate the fault conditions except single LED short. This pin is also an input pin. Pulling this pin low will shutdown the device.
7	ST1	LED string voltage monitor pin of OUT1 to achieve single LED short detection.
8	OUT1	Output current source channel 1.
9	OUT2	Output current source channel 2.
10	ST2	LED string voltage monitor pin of OUT2 to achieve single LED short detection.
11	NC	Not connect.
12	VCC	Power supply input pin.
13	UV1	External under voltage lockout threshold detection pin for OUT1.
14	EN1	Enable pin of OUT1. It can be used to set OUT1 current by PWM.
15	UV2	External under voltage lockout threshold detection pin for OUT2.
16	EN2	Enable pin of OUT2. It can be used to set OUT2 current by PWM.
	Thermal Pad	Must be electrically connected to GND plane for better thermal dissipation.



# IS32LT3126

## ORDERING INFORMATION

Automotive Range: -40°C to +125°C

Order Part No.	Package	QTY/Reel
IS32LT3126-ZLA3-TR	eTSSOP-16, Lead-free	2500

Copyright © 2018 Integrated Silicon Solution, Inc. All rights reserved. ISSI reserves the right to make changes to this specification and its products at any time without notice. ISSI assumes no liability arising out of the application or use of any information, products or services described herein. Customers are advised to obtain the latest version of this device specification before relying on any published information and before placing orders for products.

Integrated Silicon Solution, Inc. does not recommend the use of any of its products in life support applications where the failure or malfunction of the product can reasonably be expected to cause failure of the life support system or to significantly affect its safety or effectiveness. Products are not authorized for use in such applications unless Integrated Silicon Solution, Inc. receives written assurance to its satisfaction, that:

- the risk of injury or damage has been minimized;
- the user assume all such risks; and
- potential liability of Integrated Silicon Solution, Inc is adequately protected under the circumstances

# IS32LT3126

## ABSOLUTE MAXIMUM RATINGS

VCC, OUT1, OUT2, EN1, EN2, UV1, UV2, ST1, ST2	-0.3V ~ +45V
ISET1, ISET2, CTSOR, FAULTB, FAULTB_S	-0.3V ~ +7.0V
Ambient operating temperature, $T_A=T_J$	-40°C ~ +125°C
Maximum continuous junction temperature, $T_{J(MAX)}$	+150°C
Storage temperature range, $T_{STG}$	-65°C ~ +150°C
Maximum power dissipation, $P_{D(MAX)}$	2.15W
Package thermal resistance, junction to ambient (4 layer standard test PCB based on JEDEC standard), $\theta_{JA}$	46.5°C/W
Package thermal resistance, junction to thermal PAD (4 layer standard test PCB based on JEDEC standard), $\theta_{JP}$	1.617°C/W
ESD (HBM)	±2kV
ESD (CDM)	±750V

**Note 2:** Stresses beyond those listed under “Absolute Maximum Ratings” may cause permanent damage to the device. These are stress ratings only and functional operation of the device at these or any other condition beyond those indicated in the operational sections of the specifications is not implied. Exposure to absolute maximum rating conditions for extended periods may affect device reliability.

## ELECTRICAL CHARACTERISTICS

$T_J = -40^\circ\text{C} \sim +125^\circ\text{C}$ ,  $V_{CC}=12\text{V}$ , the detail refer to each condition description. Typical values are at  $T_J = 25^\circ\text{C}$ .

Symbol	Parameter	Conditions	Min.	Typ.	Max.	Unit
<b>Power Up Parameter</b>						
$V_{CC}$	Supply voltage range		5		42	V
$V_{UVLO}$	VCC under voltage lockout threshold voltage	Voltage falling	4.2	4.5	4.8	V
$V_{UVLO\_HY}$	VCC under voltage lockout voltage hysteresis			200		mV
$I_{CC}$	VCC supply current	$V_{ENx} = \text{High}$ , $R_{ISETx} = 20\text{k}\Omega$	3		5.5	mA
$I_{SD}$	Shutdown current in normal mode	$V_{ENx} = \text{Low}$ , $T_J = 25^\circ\text{C}$		1	2	mA
$I_{SD\_FLT}$	Shutdown current in fault mode	$V_{ENx} = \text{High}$ , $\text{FAULTB} = \text{Low}$ $T_J = 25^\circ\text{C}$		1	2	mA
$t_{SD}$	Both of EN pins low time for IC power shutdown		40	48	55	ms
$t_{ON}$	EN high time for IC power up	$I_{OUT} = -150\text{mA}$ , $V_{CC} = 12\text{V}$ $V_{ENx} = \text{High}$ (Note 3)			40	$\mu\text{s}$
<b>Channel Parameter</b>						
$V_{ISETx}$	The ISETx voltage			1		V
$I_{OUT}$	Output current per channel (Note 4)	$R_{ISETx} = 80\text{k}\Omega$ , $V_{HR} = 1\text{V}$	-27.5	-25	-22.5	mA
		$R_{ISETx} = 20\text{k}\Omega$ , $V_{HR} = 1\text{V}$	-106	-100	-94	
		$R_{ISETx} = 13.3\text{k}\Omega$ , $V_{HR} = 1\text{V}$	-159	-150	-141	
$V_{HR}$	Minimum headroom voltage	$V_{CC} - V_{OUT}$ , $I_{OUT} = -150\text{mA}$			1100	mV
		$V_{CC} - V_{OUT}$ , $I_{OUT} = -100\text{mA}$			800	

# IS32LT3126

## ELECTRICAL CHARACTERISTICS (CONTINUE)

$T_J = -40^{\circ}\text{C} \sim +125^{\circ}\text{C}$ ,  $V_{CC}=12\text{V}$ , the detail refer to each condition description. Typical values are at  $T_J = 25^{\circ}\text{C}$ .

Symbol	Parameter	Conditions	Min.	Typ.	Max.	Unit
$I_{OUT\_R}$	Output current per channel range	$R_{ISETx} = 80\text{k}\Omega$ , $I_{OUT} = -25\text{mA}$ $R_{ISETx} = 13.33\text{k}\Omega$ , $I_{OUT} = -150\text{mA}$	-150		-25	mA
$I_{OUT\_L}$	Output limit current per channel	$R_{ISETx} = 5\text{k}\Omega$	-290	-230	-170	mA
$\Delta I_{OUT}$	Current matching	$R_{ISETx} = 20\text{k}\Omega$	-4		4	%
$t_{SL}$	Current slew time	Enable by ENx pin, current rise/fall between 0%~100%		4		$\mu\text{s}$
$I_{LEAK}$	Leakage current per channel	$V_{ENx} = \text{Low}$ , $V_{OUT} = 0\text{V}$ , $V_{CC} = 42\text{V}$			1	$\mu\text{A}$
<b>Fault Protect Parameter</b>						
$t_{FD}$	Fault deglitch time	Fault must be present at least this long to trigger the fault detect		25		$\mu\text{s}$
$V_{FAULTB}$	FAULTB pin voltage	Sink current=20mA		0.2	0.4	V
$R_{FAULTB}$	FAULTB pin internal pull up			210	300	K $\Omega$
$V_{FAULTB\_IH}$	FAULTB pin input high enable threshold				2	V
$V_{FAULTB\_IL}$	FAULTB pin input low disable threshold		0.8			V
$V_{FAULTB\_S}$	FAULTB_S pin voltage	Sink current=20mA		0.2	0.4	V
$V_{SCD}$	OUTx pin short to GND threshold	Measured at OUTx	1.0	1.2	1.5	V
$V_{SCD\_HY}$	OUTx pin short to GND hysteresis	Measured at OUTx		220		mV
$V_{OCD}$	OUTx pin open threshold	Measured at $(V_{CC} - V_{OUTx})$	150	225	300	mV
$V_{OCD\_HY}$	OUTx pin open hysteresis	Measured at $(V_{CC} - V_{OUTx})$		100		mV
$I_{CST}$	CSTOR pin leakage current	$V_{CSTOR} = 5.5\text{V}$		5	10	$\mu\text{A}$
$T_{RO}$	Thermal rollback threshold	(Note 3)		145		$^{\circ}\text{C}$
$T_{SD}$	Thermal shutdown threshold	(Note 3)		165		$^{\circ}\text{C}$
$T_{HY}$	Over-temperature hysteresis	(Note 3)		25		$^{\circ}\text{C}$
<b>Logic Input</b>						
$V_{EN}$	ENx input voltage threshold	Voltage rising	1.18	1.23	1.28	V
$V_{ENHY}$	ENx input hysteresis	(Note 3)		40		mV
$f_{PWM}$	PWM frequency to ENx	(Note 3)			1	kHz
$V_{UV}$	UVx input voltage threshold	Voltage rising	1.18	1.23	1.28	V
$V_{UVHY}$	UVx input hysteresis			40		mV
$V_{ST}$	STx input voltage threshold	Voltage falling	1.12	1.16	1.20	V
$V_{STHY}$	STx Input hysteresis			40		mV
$R_{STPL}$	STx pull up resistor	$V_{ST} = 1\text{V}$		500		K $\Omega$

**Note 3:** Guaranteed by design.

**Note 4:** Output current accuracy is not intended to be guaranteed at output voltages less than 1.5V.

# IS32LT3126

## TYPICAL PERFORMANCE CHARACTERISTICS

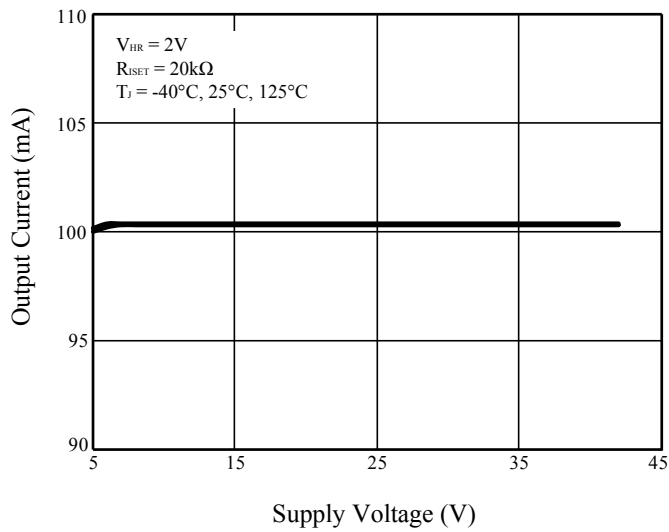

Figure 3  $I_{OUT}$  vs.  $V_{CC}$

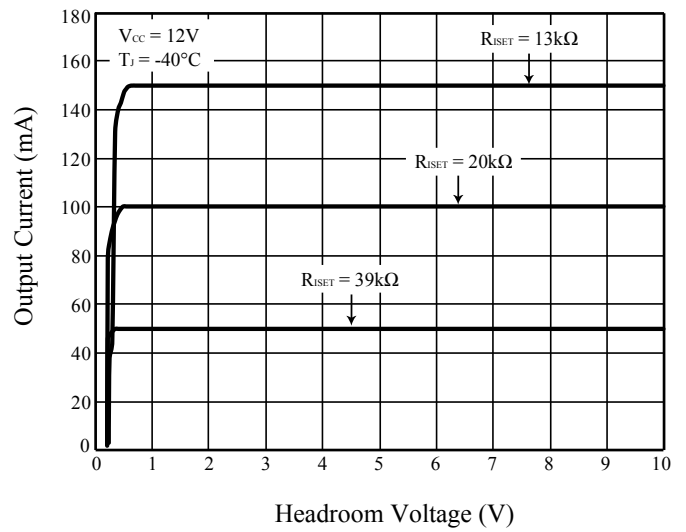

Figure 4  $I_{OUT}$  vs.  $V_{HR}$

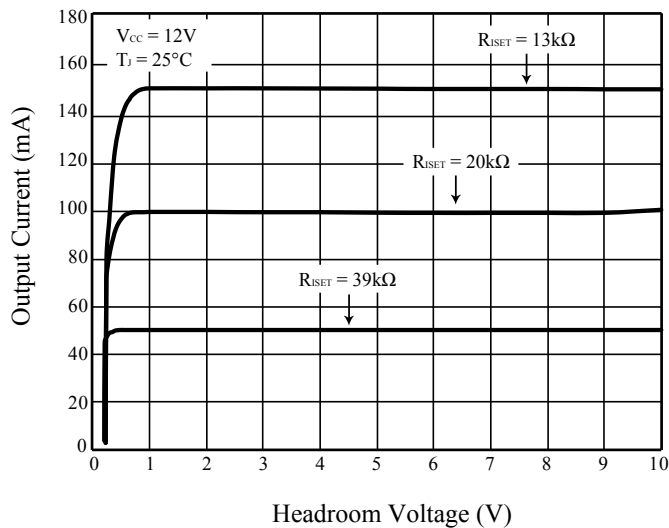

Figure 5  $I_{OUT}$  vs.  $V_{HR}$

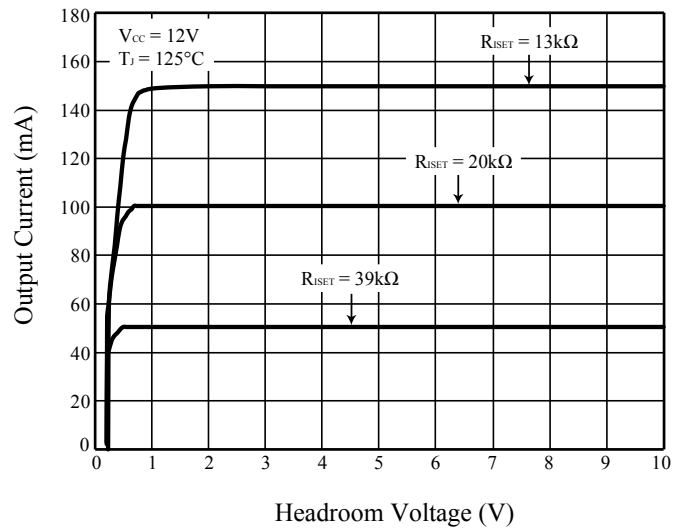

Figure 6  $I_{OUT}$  vs.  $V_{HR}$

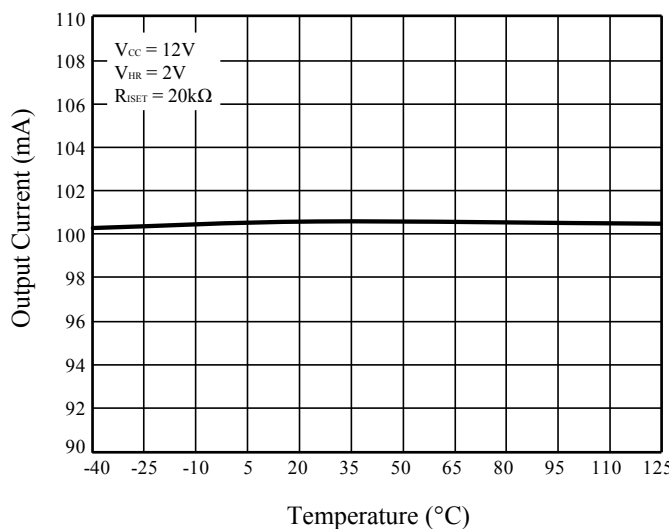

Figure 7  $I_{OUT}$  vs.  $T_J$

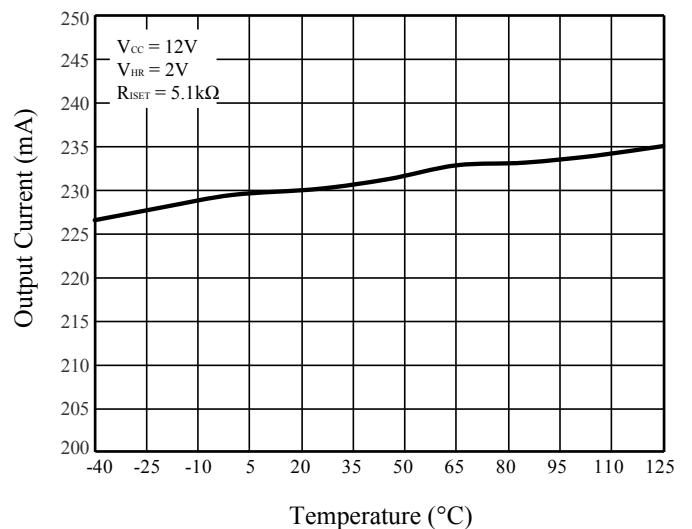
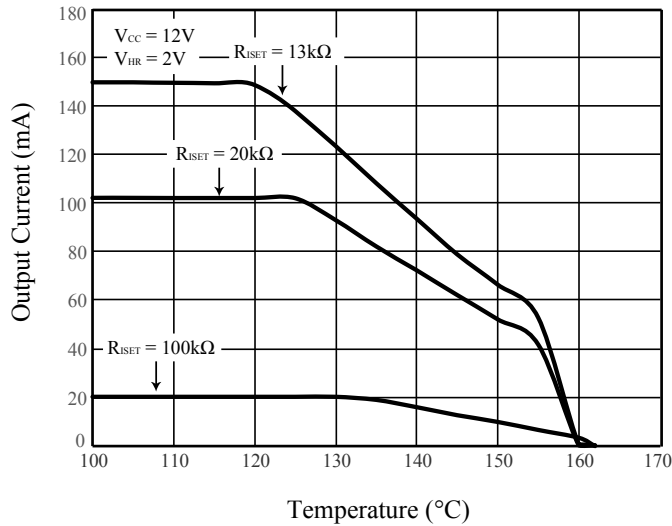
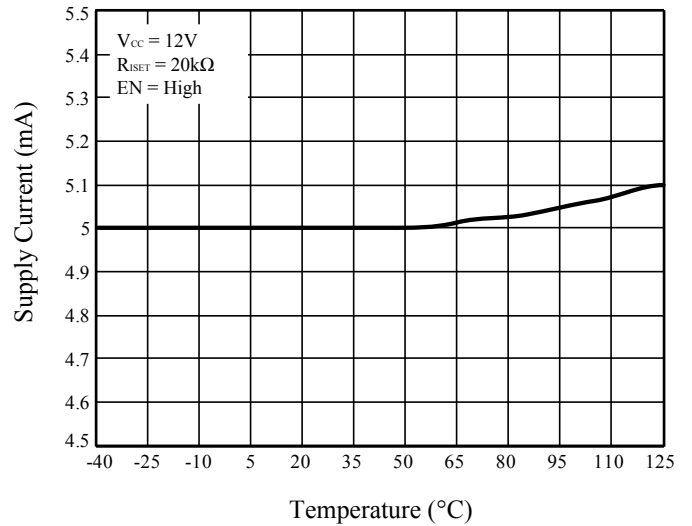

Figure 8  $I_{OUT\_L}$  vs.  $T_J$

# IS32LT3126



**Figure 9**  $I_{OUT}$  vs.  $T_A$  (Thermal Rolloff)



**Figure 10**  $I_{CC}$  vs.  $T_J$

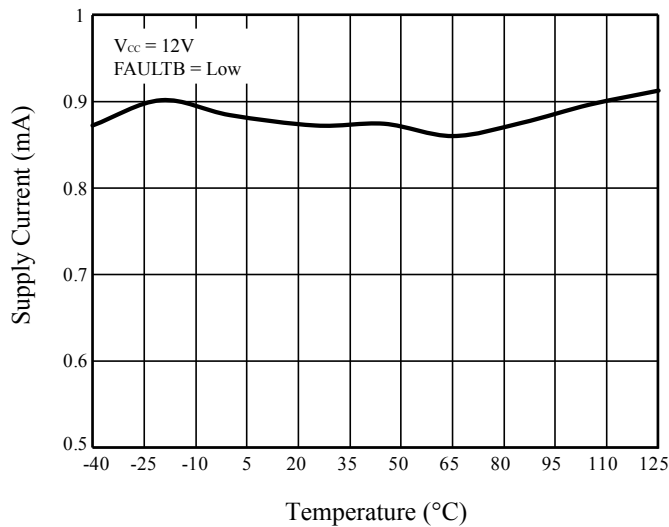

**Figure 11**  $I_{SD\_FLT}$  vs.  $T_J$

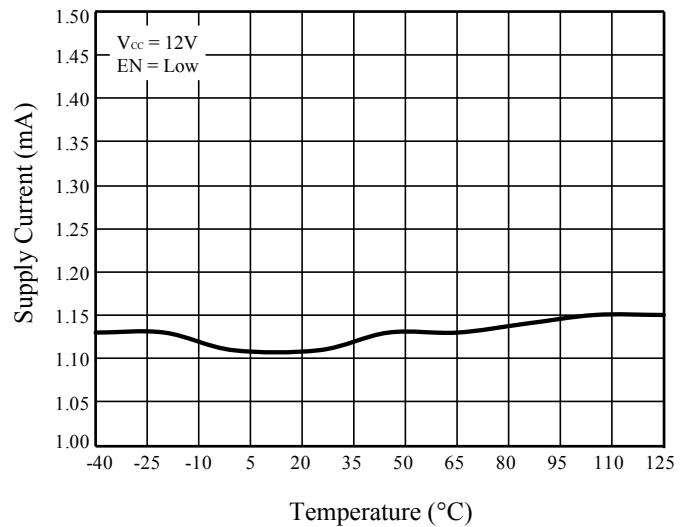

**Figure 12**  $I_{SD}$  vs.  $T_J$

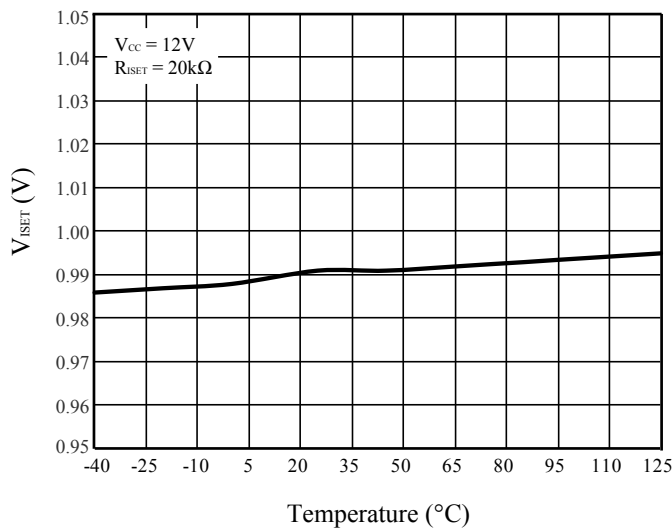

**Figure 13**  $V_{ISET}$  vs.  $T_J$

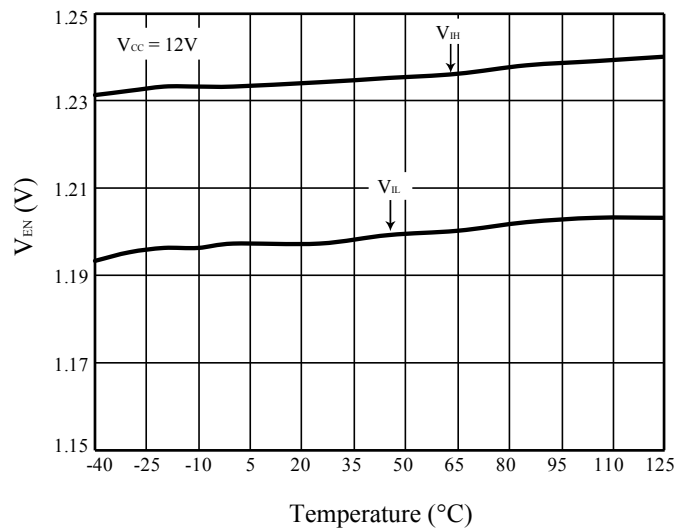

**Figure 14**  $V_{EN}$  vs.  $T_J$



# IS32LT3126

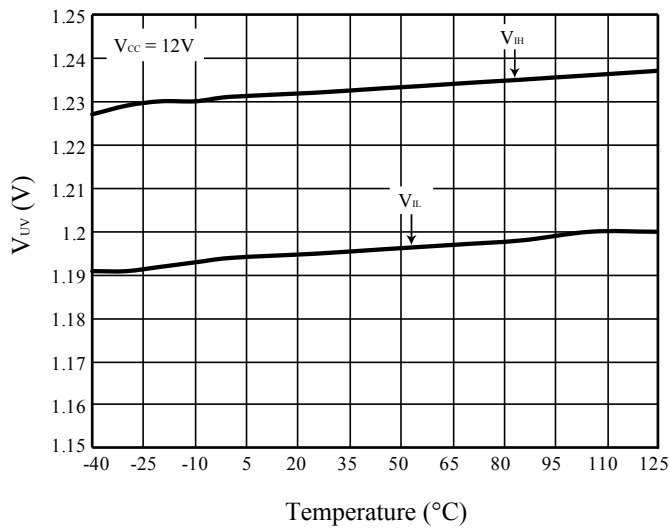

**Figure 15**  $V_{UV}$  vs.  $T_J$

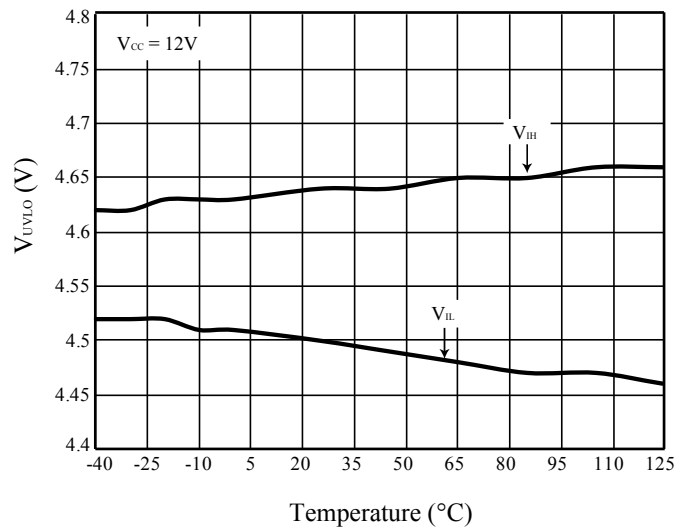

**Figure 16**  $V_{UVLO}$  vs.  $T_J$

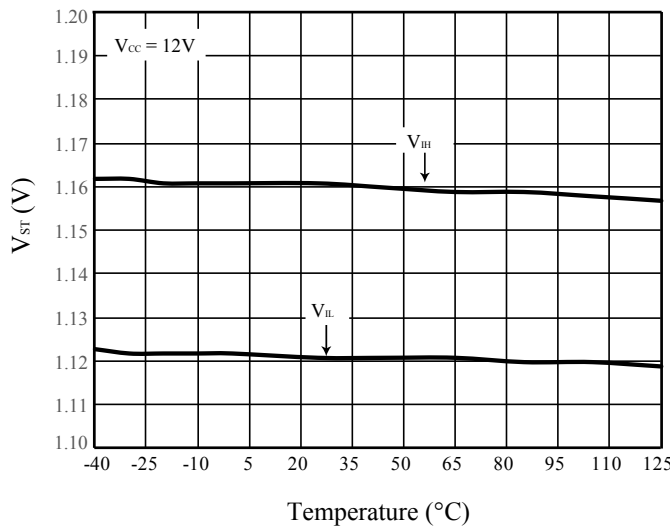

**Figure 17**  $V_{ST}$  vs.  $T_J$

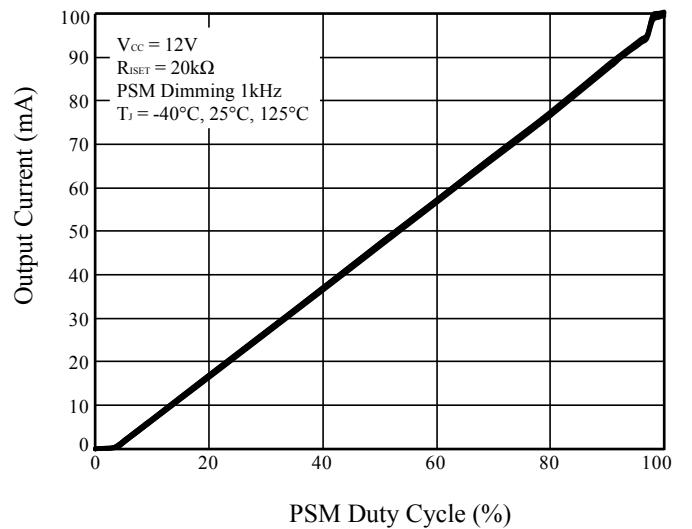

**Figure 18** PSM Dimming at 1kHz

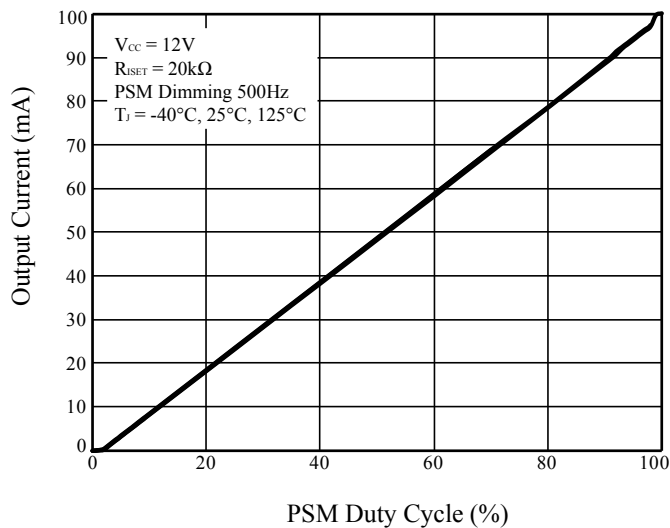

**Figure 19** PSM Dimming at 500Hz

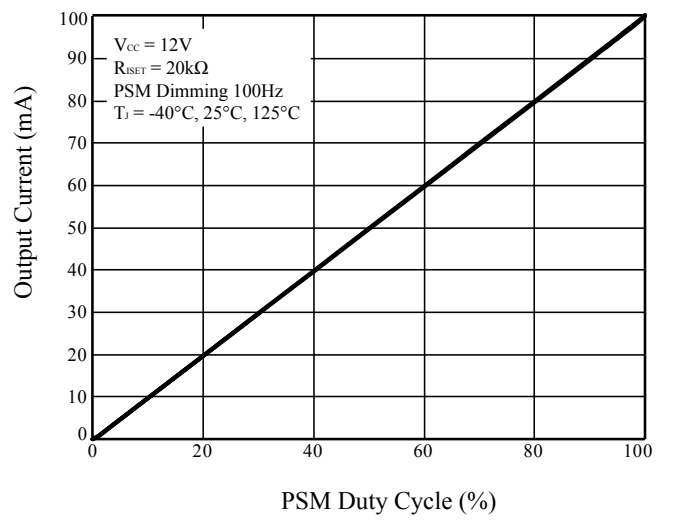

**Figure 20** PSM Dimming at 100Hz

# IS32LT3126

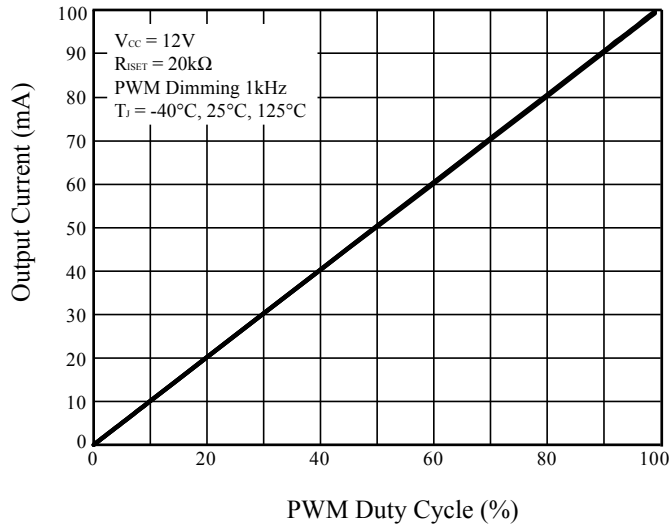

Figure 21 PWM Dimming at 1kHz

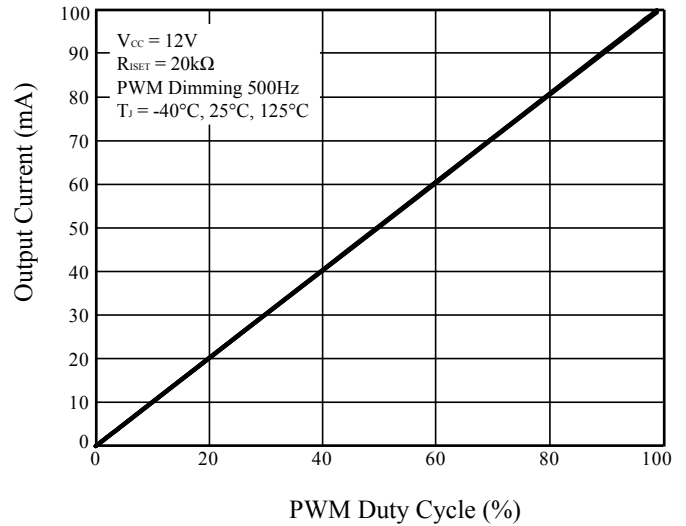

Figure 22 PWM Dimming at 500Hz

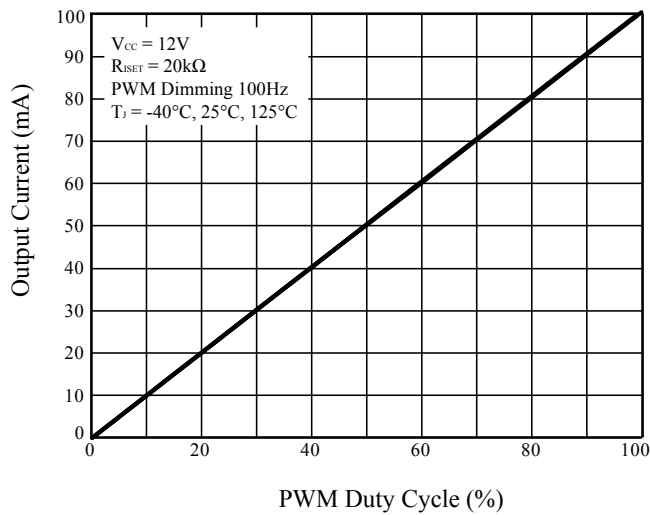

Figure 23 PWM Dimming at 100Hz

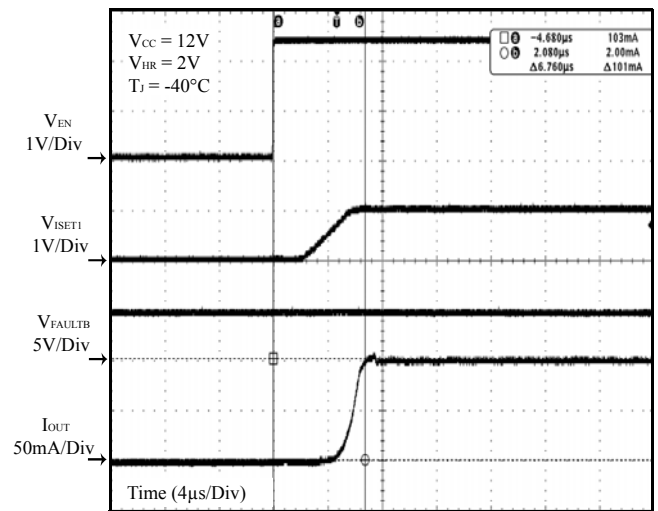

Figure 24 EN On

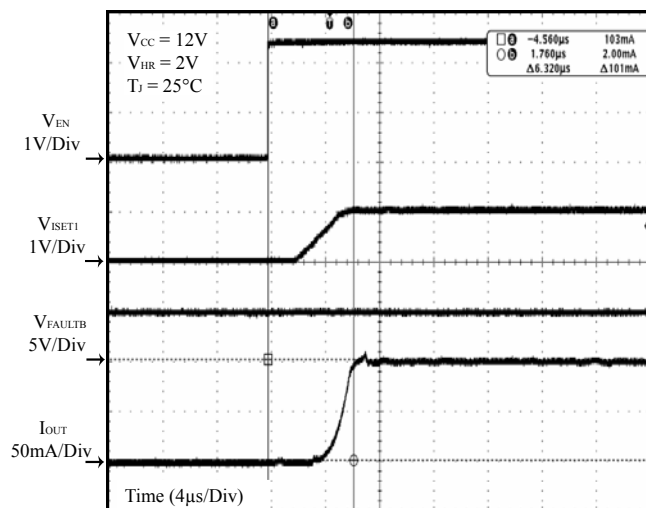

Figure 25 EN On

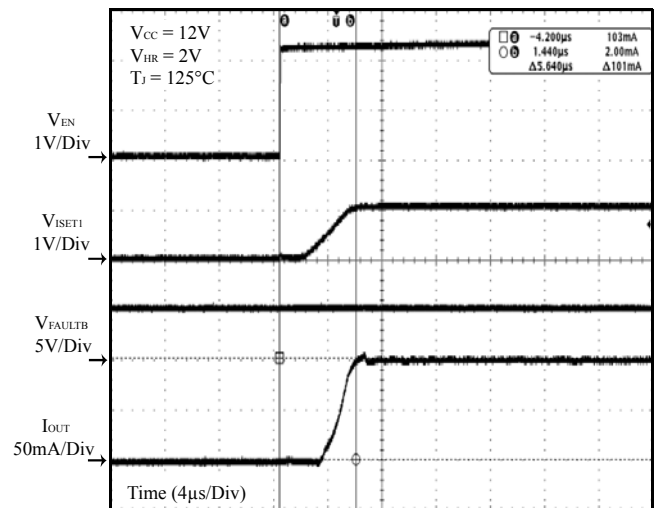

Figure 26 EN On

# IS32LT3126

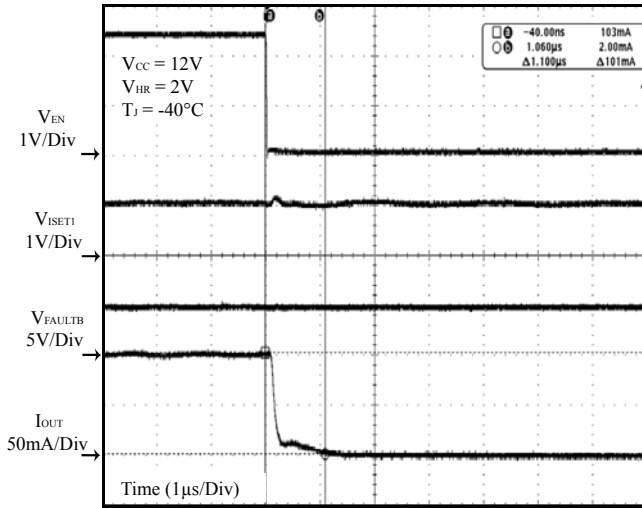

Figure 27 EN Off

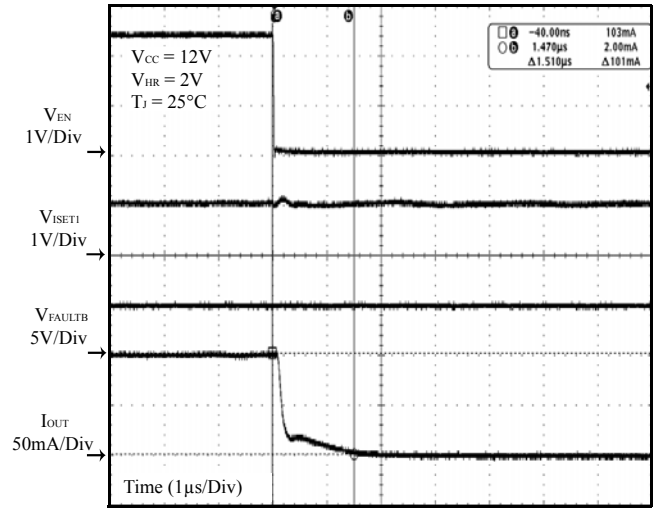

Figure 28 EN Off

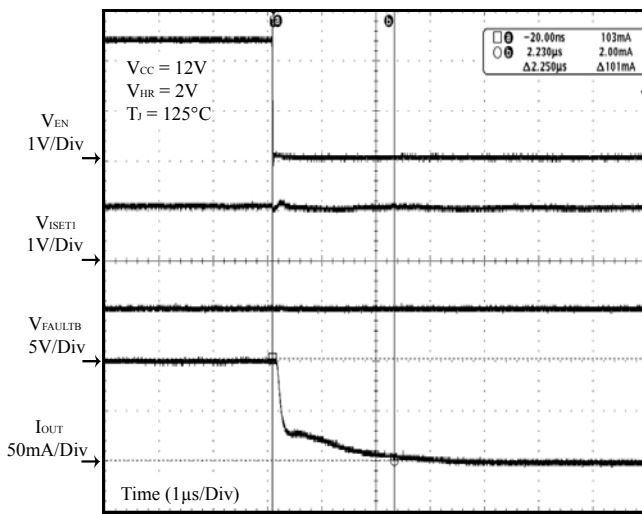

Figure 29 EN Off

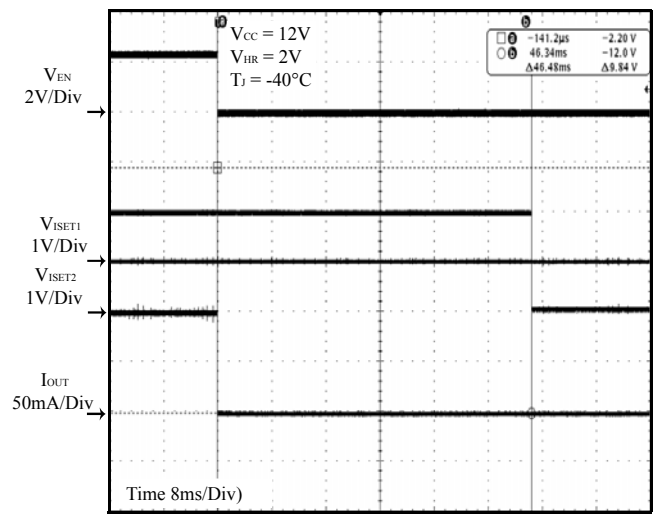

Figure 30  $t_{SD}$

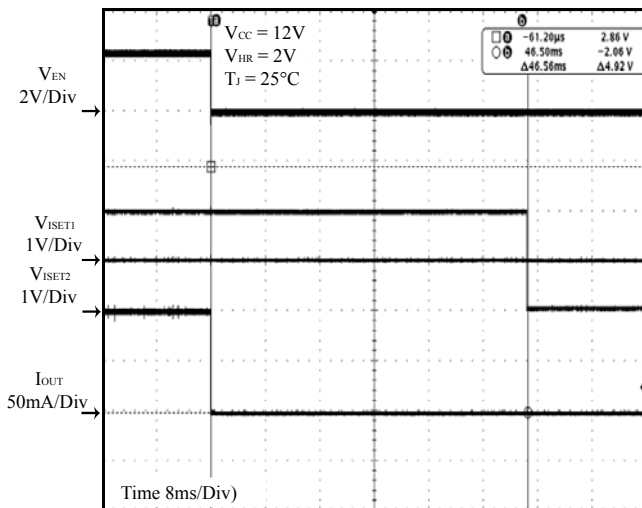

Figure 31  $t_{SD}$

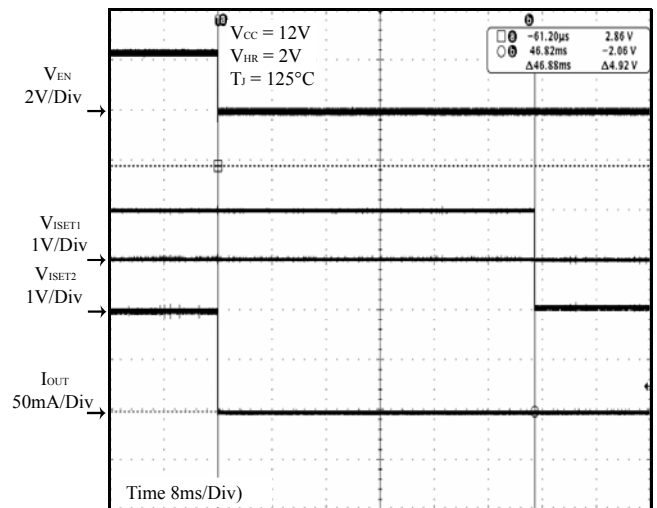
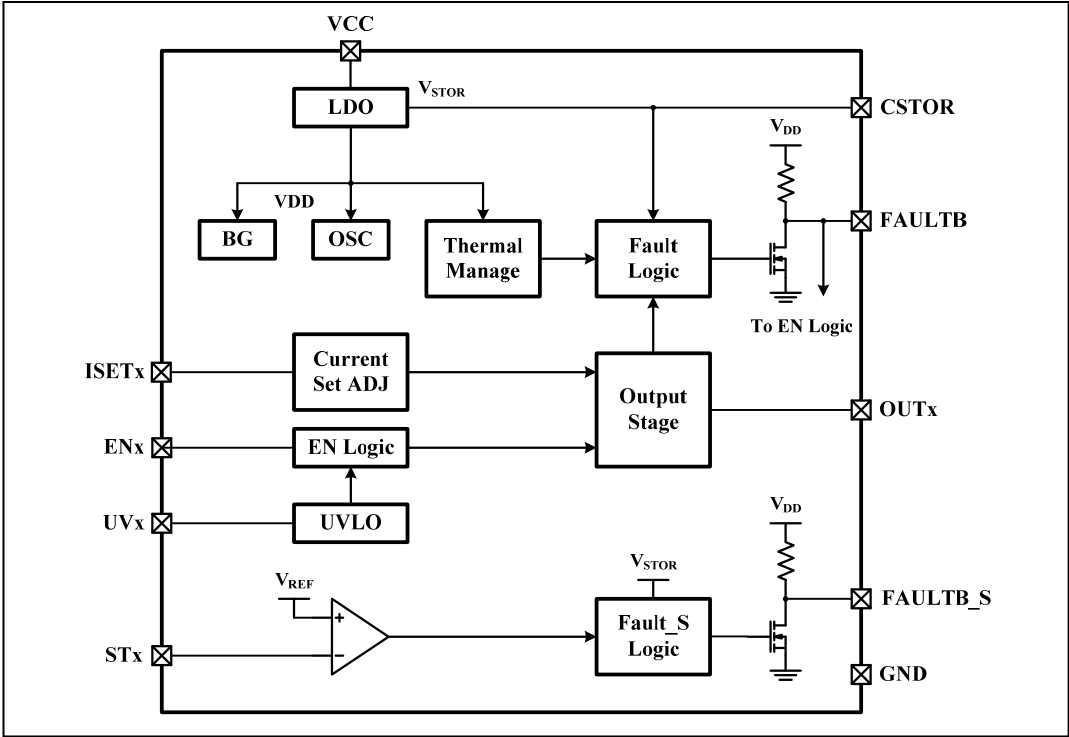

Figure 32  $t_{SD}$

# IS32LT3126

## FUNCTIONAL BLOCK DIAGRAM



# IS32LT3126

## APPLICATION INFORMATION

The IS32LT3126 is a 2-channel linear LED current source optimized to drive automotive interior or exterior LED light which can be dimmed via Power Supply Modulation (PSM) or by digitally driving the EN pin.

Each of the 2 output channels is capable of 150mA. The output current is set by two reference resistors ( $R_{ISETx}$ ); one for each channel.

### OUTPUT CURRENT SETTING

A single resistor ( $R_{ISETx}$ ) controls the maximum output current for each channel. The resistor value for a specific current level is calculated using the following Equation (1):

$$R_{ISET} = \frac{2000}{I_{SET}} \quad (1)$$

(13.33kΩ ≤  $R_{ISET}$  ≤ 80kΩ)

$R_{ISET}$  need to be chosen 1% accuracy resistor with good temperature characteristic to ensure stable output current.

The device is protected from an output overcurrent condition caused by a too low value  $R_{ISETx}$ , by internally limiting the maximum current to  $I_{OUT\_L}$ .

If only one channel is used, the EN pin of the unused channel should be tied to GND to prevent unwanted fault reporting.

### POWER SUPPLY MODULATION DIMMING

The IS32LT3126 can operate with Power Supply Modulation (PSM) where the device's power supply is pulse width modulated to achieve LED dimming. The IS32LT3126 stability is not affected by operation with PSM. To get better dimming linearity, the recommended PSM frequency can be in the range of 100Hz to 300Hz, (200Hz Typ.) and input capacitor,  $C_{VCC}$ , should be low value (0.1μF Typ.) to ensure rapid discharge during PSM low period.

### CSTOR OPERATION

To keep the IC operating normally during condition of PSM when  $V_{CC}$  goes to zero,  $C_{STOR}$  capacitor provides the keep-alive current needed to power the digital counter and the fault flag circuits. A capacitor value of 2.2μF is recommended. The keep-alive time could be roughly calculated by the following Equation (2):

$$t_{alive} = \frac{2.5V \times C_{STOR}}{I_{CST}} \quad (2)$$

### ENx PINS OPERATION

The voltage at the ENx pins must be higher than  $V_{EN}$  to enable the channel and below ( $V_{EN} - V_{ENHY}$ ) to disable the channel. The ENx pins of the IS32LT3126 can

accept a PWM signal to implement LED dimming. LED average current may be computed using the following Equation (3).

$$I_{LED} = I_{MAX} \times D_{PWM} \quad (3)$$

$I_{MAX}$  is computed using Equation (1) and  $D_{PWM}$  is the duty cycle. To guarantee a reasonably good dimming effect, recommend PWM frequency in the range of 100Hz ~ 1kHz. Driving the ENx pins with a PWM signal can effectively adjust the LED intensity. The PWM signal voltage levels must meet the ENx pins input voltage levels,  $V_{EN}$ . Tie them to VCC pin via a 10kΩ resistor when ENx pins are unused; do not leave them floating.

### UVx PINS OPERATION

The IC has an internal VCC UVLO set at  $V_{UVLO}$ . However, it may be desirable to externally set an UVLO to track the number of LED's used in the string. For PSM dimming application, the higher UVLO will track the PSM off time to a pre-determined VCC level. In addition, it is necessary to prevent false LED open detection due to the LED string losing its headroom voltage, such as when VCC rises up from zero during power up or PSM dimming. The UVx pin can be used to independently set a VCC under voltage lockout threshold via a resistor divider for each channel.

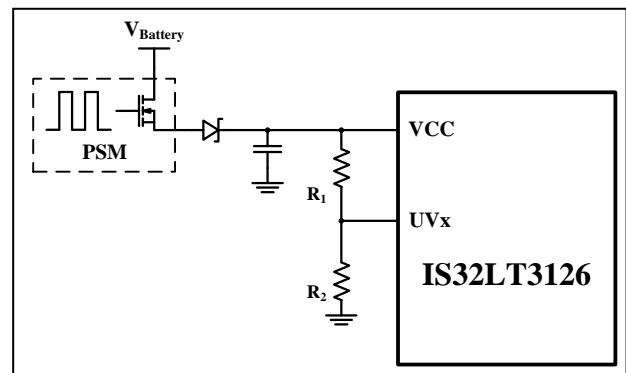

Figure 33 UVx Pins Operation

This external UVLO threshold voltage can be computed using the following Equation (4):

$$V_{CC\_UVLO} = V_{UV} \times \frac{R_1 + R_2}{R_2} \quad (4)$$

Any unused UVLO pin must be tied to VCC pin via a 10kΩ resistor; do not leave it floating.

To prevent false open detection, the external UVLO threshold voltage should be set at Equation (5):

$$V_{CC\_UVLO} > V_{LED\_MAX} + V_{OCD} \quad (5)$$

Where  $V_{LED\_MAX}$  is the maximum LED string forward voltage on the output channel.

# IS32LT3126

## STx PINS OPERATION

IS32LT3126 device features single LED short detection using a resistor divider on the STx pins. In the case of any single LED short will result in that the STx pin voltage to drop below the threshold voltage  $V_{ST}$  and remains for  $t_{FD}$ , the FAULTB\_S pin pulls low to report the failure to host and all channels continue sourcing current. If FAULTB\_S pin is tied to FAULTB pin, the FAULTB\_S pin pulls down the FAULTB pin together that turns off the no fault condition channel but keep 4mA sourcing on fault channel for recovery detection. In multiple LEDs per string application, set the detection threshold voltage  $V_{DT}$  into below voltage range:

$$(N - 1) \times V_{F\_max} < V_{DT} < N \times V_{F\_min} \quad (6)$$

Where, N is the number of LEDs in the string.  $V_{F\_max}$  and  $V_{F\_min}$  are the maximum and minimum forward voltage of a single LED.

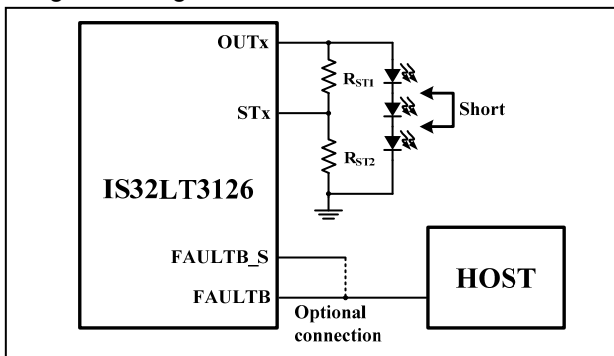

Figure 34 STx Pins Operation

The detection threshold voltage  $V_{DT}$  is calculated by the following Equation (7):

$$V_{DT} = V_{ST} \times \frac{R_{ST1} + R_{ST2}}{R_{ST2}} \quad (7)$$

If single LED short detection is unused, the unused STx pin should be tied to its corresponding OUTx pin.

## OUTPUT STATE DETECTION AND FAULT DIAGNOSTIC

IS32LT3126 offers a fault diagnostic function. Output short to GND/VCC, LED string open/short, ISET pins short/open and over temperature shutdown will trigger this function.

An output short to GND or VCC is detected as a fault if the OUTx pin voltage drops below the short detect voltage threshold  $V_{SCD}$  or VCC to OUTx drop voltage is lower than  $V_{OCD}$  and remains below the threshold for  $t_{FD}$ . Then the fault channel will change to source a 4mA current for recovery detection and the other channel will turn off. The FAULTB pin will be pulled low to indicate the fault condition. This state will recover after the fault condition is removed.

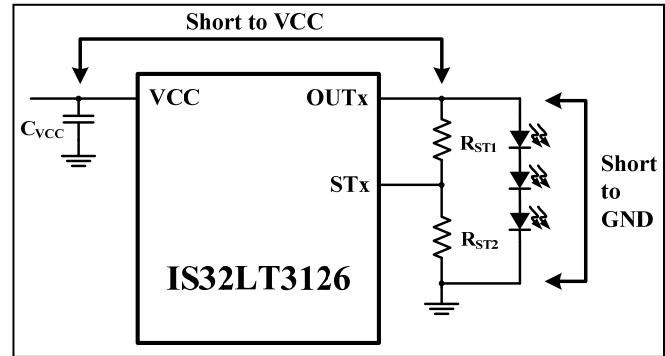

Figure 35 OUTx Pins Short Operation

In the event the LED channel is open circuited, the OUTx pin voltage will go up close to  $V_{CC}$ . If VCC to OUTx drop voltage remains below the threshold  $V_{OCD}$  for  $t_{FD}$ , the fault channel will change to source a 4mA current for recovery detection and the another channel will turn off. The FAULTB pin will be pulled low to indicate the fault condition. The state will recover after the open condition is removed.

If the ISETx pin is either short or open, the FAULTB pin will pull low to assert the fault and the both channels will turn off. The state will recover after the fault condition is removed.

## FAULTB PARALLEL INTERCONNECTION

For LED lighting systems which require the complete lighting system be shut down when a fault is detected, the FAULTB pin can be used in a parallel connection with multiple IS32LT3126 devices as shown in Figure 2. A detected fault output by one device will pull low the FAULTB pins of the other parallel connected devices and simultaneously turn them off. This satisfies the “One-Fail-All-Fail” operating requirement.

## THERMAL ROLLBACK OF OUTPUT CURRENT

To protect the IC from damage due to high power dissipation, the temperature of the die is monitored. When the temperature of the die is below the thermal rollback start threshold of 145°C (Typ.), the dual output current maximum is the value set by the selection of  $R_{ISETx}$ . When the die temperature is between the thermal rollback start threshold 145°C (Typ.) and the over temperature shutdown threshold 165°C (Typ.), the output current decreases linearly from the maximum value. During the rollback, the FAULTB pin will not assert this as a fault.

The rollback is related to  $R_{ISET}$  value:

$$I_{OUT\_RO} = I_{OUT} - \frac{K \times (T_j - 145^\circ C)}{R_{ISET}} \quad (8)$$

Where  $145^\circ C \leq T_j \leq 165^\circ C$  and  $K=49$ .

# IS32LT3126

## THERMAL SHUTDOWN

In the event that the die temperature exceeds 165°C, the device will go into shutdown mode. Both channels (OUTx) will turn off. The FAULTB pin will pull low to indicate the fault. At this point, the IC begins to cool off.

Any attempt to enable one or both of the channels back to the source condition before the IC cooled to  $T_J < 140^\circ\text{C}$  will be blocked and the IC will not be allowed to restart. The device will not resume operation until the junction temperature goes below 140°C.

**Table 1 Fault Table**

Fault Type	Fault Condition	Fault Channel	Another Channel	FAULTB	FAULTB_S	Recovery
ISETx open	ISETx pin current close to zero	Off	Off	Low	High	ISETx pin current goes back normal
ISETx short	ISETx pin voltage close to zero	Off	Off	Low	High	ISETx pin voltage goes back normal
LED string open (OUTx short to VCC)	$(V_{CC} - V_{OUTx}) < V_{OCD}$	4mA for recovery detection	Off	Low	High	$(V_{CC} - V_{OUTx}) > (V_{OCD} + V_{OCD\_HY})$
LED string short (OUTx short to GND)	$V_{OUTx} < V_{SCD}$	4mA for recovery detection	Off	Low	High	$V_{OUTx} > (V_{SCD} + V_{SCD\_HY})$
One LED short	STx pin voltage drops below $V_{ST}$	Keep normal sourcing		High	Low	STx pin voltage rises above $(V_{ST} + V_{STHY})$
	FAULTB_S tied to FAULTB and STx pin voltage drops below $V_{ST}$	4mA for recovery detection	Off	Pulled low by FAULTB_S	Low	STx pin voltage rises above $(V_{ST} + V_{STHY})$
Thermal rollback	$T_J > T_{RO}$	Output current linearly decreases following $T_J$		High	High	$T_J < T_{RO}$
Thermal shutdown	$T_J > T_{SD}$	Off		Low	High	$T_J < (T_{SD} - T_{HY})$

## THERMAL CONSIDERATIONS

The package thermal resistance,  $\theta_{JA}$ , determines the amount of heat that can pass from the silicon die to the surrounding ambient environment. The  $\theta_{JA}$  is a measure of the temperature rise created by power dissipation and is usually measured in degree Celsius per watt ( $^\circ\text{C}/\text{W}$ ). The junction temperature,  $T_J$ , can be calculated by the rise of the silicon temperature,  $\Delta T$ , the power dissipation,  $P_D$ , and the package thermal resistance,  $\theta_{JA}$ , as in Equation (9) and (10):

$$P_D = V_{CC} \times I_{CC} + \sum_{x=1}^2 (V_{CC} - V_{OUTx}) \times I_{OUTx} \quad (9)$$

and,

$$T_J = T_A + \Delta T = T_A + P_D \times \theta_{JA} \quad (10)$$

Where  $V_{CC}$  is the supply voltage,  $V_{OUTx}$  is the OUTx voltage and  $T_A$  is the ambient temperature. When operating the chip at high ambient temperatures, or when driving maximum load current, care must be taken to avoid exceeding the package power dissipation limits. The maximum power dissipation can be calculated using the following Equation (11):

$$P_{D(MAX)} = \frac{125^\circ\text{C} - 25^\circ\text{C}}{\theta_{JA}} \quad (11)$$

So,

$$P_{D(MAX)} = \frac{125^\circ\text{C} - 25^\circ\text{C}}{46.5^\circ\text{C}/\text{W}} \approx 2.15\text{W}$$

Figure 36, show the power derating of the IS32LT3126 on a JEDEC boards (in accordance with JESD 51-5 and JESD 51-7) standing in still air. The thermal resistance is achieved by mounting the IS32LT3126 on a standard FR4 double-sided printed circuit board (PCB) with a copper area of a few square inches on each side of the board under the IS32LT3126. Multiple thermal vias, as shown in Figure 37, help to conduct the heat from the exposed pad of the IS32LT3126 to the copper on each side of the board. The thermal resistance can be reduced by using a metal substrate or by adding a heatsink.

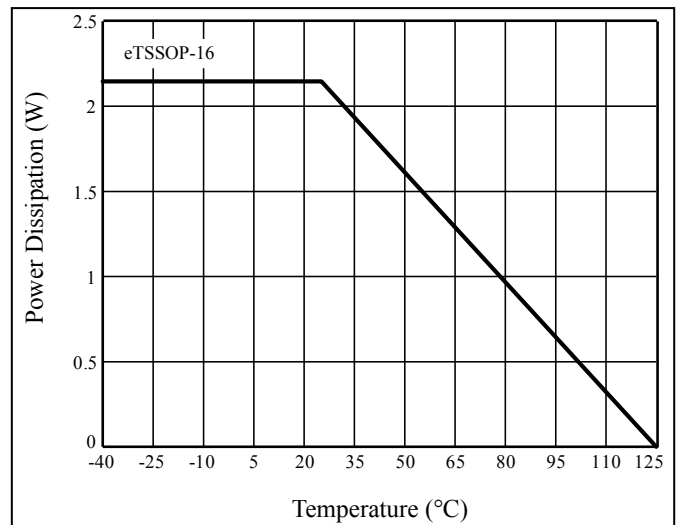

**Figure 36** Dissipation Curve

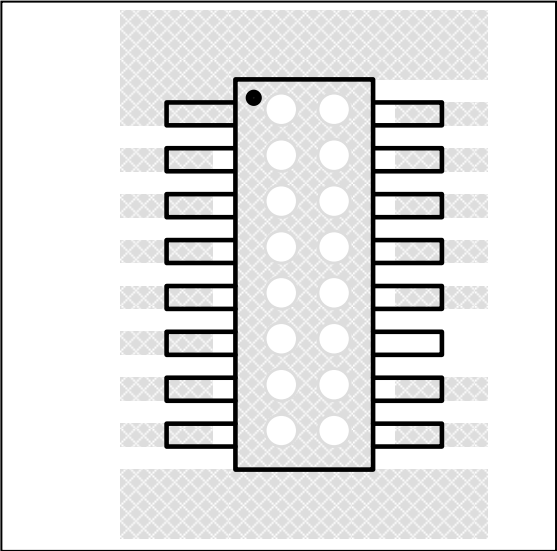

Figure 37 Board Via Layout For Thermal Dissipation



# IS32LT3126

## CLASSIFICATION REFLOW PROFILES

Profile Feature	Pb-Free Assembly
Preheat & Soak Temperature min (T <sub>smin</sub> ) Temperature max (T <sub>smax</sub> ) Time (T <sub>smin</sub> to T <sub>smax</sub> ) (t <sub>s</sub> )	150°C 200°C 60-120 seconds
Average ramp-up rate (T <sub>smax</sub> to T <sub>p</sub> )	3°C/second max.
Liquidous temperature (T <sub>L</sub> ) Time at liquidous (t <sub>L</sub> )	217°C 60-150 seconds
Peak package body temperature (T <sub>p</sub> )*	Max 260°C
Time (t <sub>p</sub> )** within 5°C of the specified classification temperature (T <sub>c</sub> )	Max 30 seconds
Average ramp-down rate (T <sub>p</sub> to T <sub>smax</sub> )	6°C/second max.
Time 25°C to peak temperature	8 minutes max.

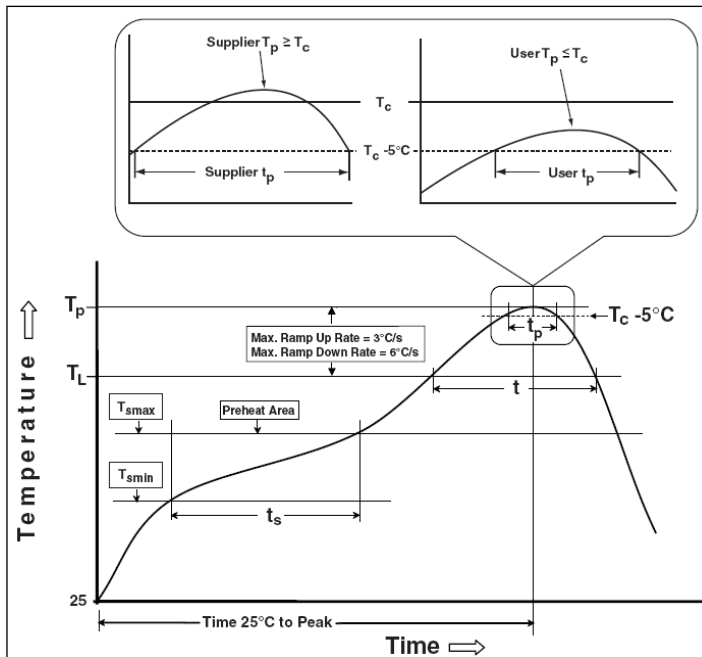
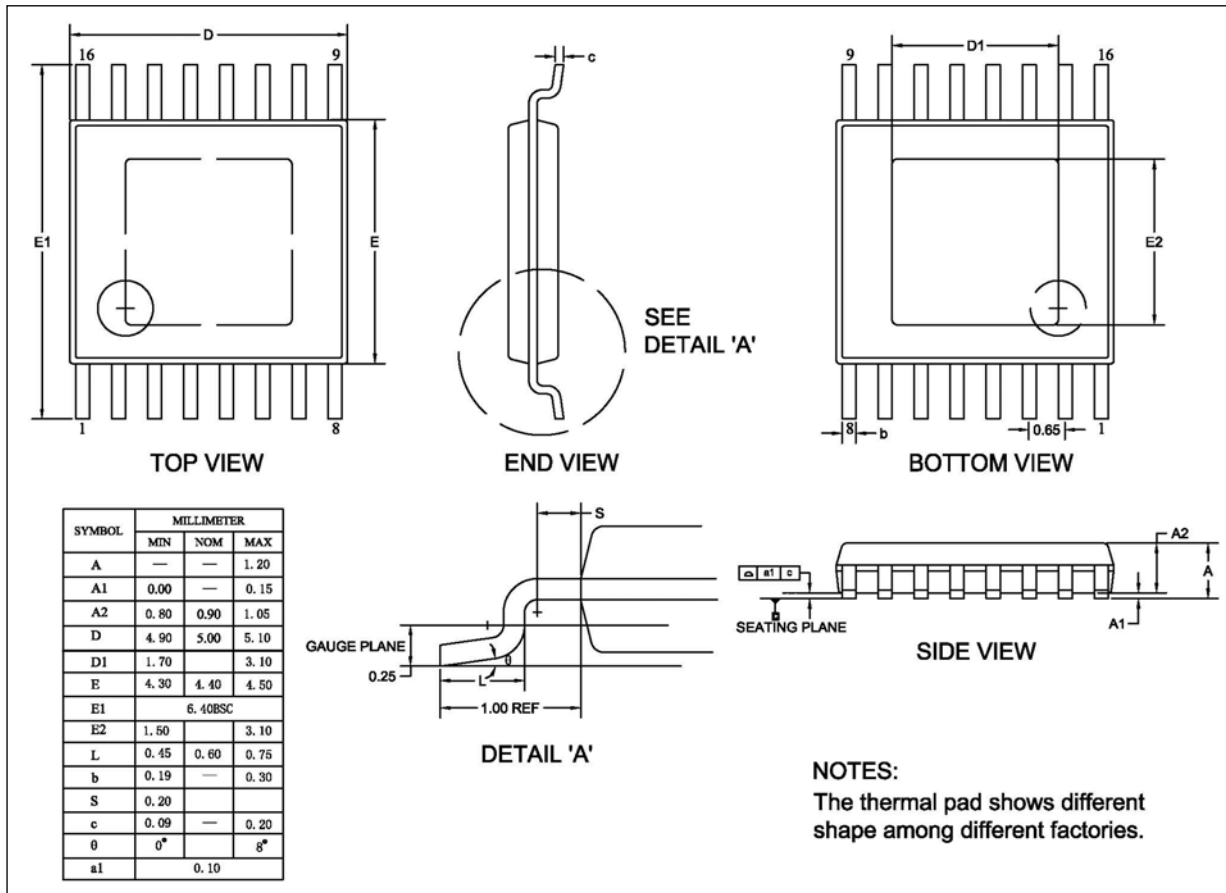

Figure 38 Classification Profile

# IS32LT3126

## PACKAGE INFORMATION

### eTSSOP-16



# IS32LT3126

## RECOMMENDED LAND PATTERN

### eTSSOP-16

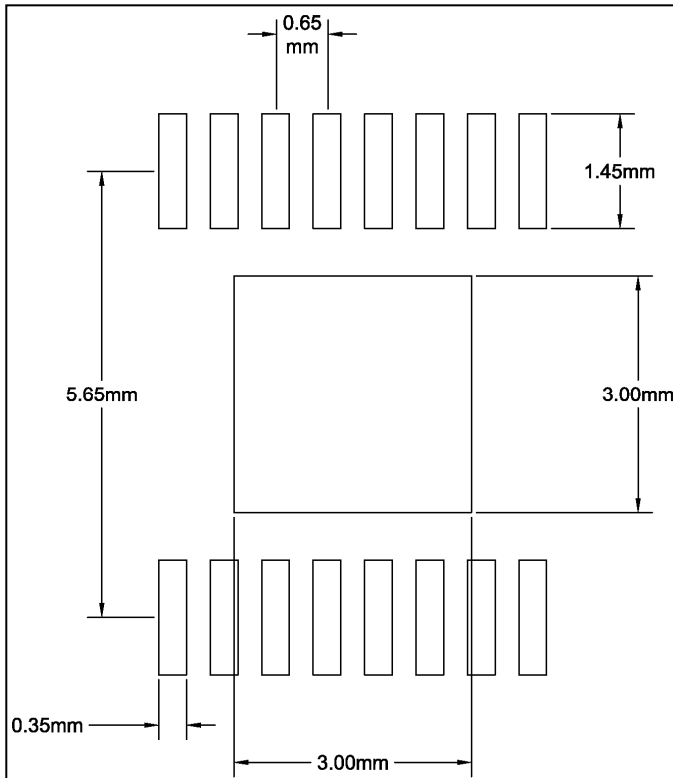

#### Note:

1. Land pattern complies to IPC-7351.
2. All dimensions in MM.
3. This document (including dimensions, notes & specs) is a recommendation based on typical circuit board manufacturing parameters. Since land pattern design depends on many factors unknown (eg. user's board manufacturing specs), user must determine suitability for use.



# IS32LT3126

---

## REVISION HISTORY

Revision	Detail Information	Date
0A	Initial release	2017.09.09
0B	Update curves and detail description	2018.01.05
A	Release to final version	2018.04.10

Компания «Океан Электроники» предлагает заключение долгосрочных отношений при поставках импортных электронных компонентов на взаимовыгодных условиях!

Наши преимущества:

- Поставка оригинальных импортных электронных компонентов напрямую с производств Америки, Европы и Азии, а так же с крупнейших складов мира;
- Широкая линейка поставок активных и пассивных импортных электронных компонентов (более 30 млн. наименований);
- Поставка сложных, дефицитных, либо снятых с производства позиций;
- Оперативные сроки поставки под заказ (от 5 рабочих дней);
- Экспресс доставка в любую точку России;
- Помощь Конструкторского Отдела и консультации квалифицированных инженеров;
- Техническая поддержка проекта, помощь в подборе аналогов, поставка прототипов;
- Поставка электронных компонентов под контролем ВП;
- Система менеджмента качества сертифицирована по Международному стандарту ISO 9001;
- При необходимости вся продукция военного и аэрокосмического назначения проходит испытания и сертификацию в лаборатории (по согласованию с заказчиком);
- Поставка специализированных компонентов военного и аэрокосмического уровня качества (Xilinx, Altera, Analog Devices, Intersil, Interpoint, Microsemi, Actel, Aeroflex, Peregrine, VPT, Syfer, Eurofarad, Texas Instruments, MS Kennedy, Miteq, Cobham, E2V, MA-COM, Hittite, Mini-Circuits, General Dynamics и др.);

Компания «Океан Электроники» является официальным дистрибьютором и эксклюзивным представителем в России одного из крупнейших производителей разъемов военного и аэрокосмического назначения «JONHON», а так же официальным дистрибьютором и эксклюзивным представителем в России производителя высокотехнологичных и надежных решений для передачи СВЧ сигналов «FORSTAR».



## JONHON

«JONHON» (основан в 1970 г.)

Разъемы специального, военного и аэрокосмического назначения:

(Применяются в военной, авиационной, аэрокосмической, морской, железнодорожной, горно- и нефтедобывающей отраслях промышленности)

«FORSTAR» (основан в 1998 г.)

ВЧ соединители, коаксиальные кабели, кабельные сборки и микроволновые компоненты:

(Применяются в телекоммуникациях гражданского и специального назначения, в средствах связи, РЛС, а так же военной, авиационной и аэрокосмической отраслях промышленности).



Телефон: 8 (812) 309-75-97 (многоканальный)

Факс: 8 (812) 320-03-32

Электронная почта: [ocean@oceanchips.ru](mailto:ocean@oceanchips.ru)

Web: <http://oceanchips.ru/>

Адрес: 198099, г. Санкт-Петербург, ул. Калинина, д. 2, корп. 4, лит. А