



The engineer's choice

ebmpapst

4606 ZWU-879

INDEX

1 General..... 3

2 Mechanics..... 3

 2.1 GENERAL 3

 2.2 CONNECTIONS..... 4

3 Operating Data 5

 3.1 ELECTRICAL OPERATING DATA..... 5

 3.2 OPERATING DATA - ELECTRICAL INTERFACE -OUTPUT 6

 3.3 ELECTRICAL FEATURES 6

 3.4 AERODYNAMIC 6

 3.5 SOUND DATA 7

4 Environment 8

 4.1 GENERAL 8

 4.2 CLIMATIC REQUIREMENTS*)..... 8

5 Safety 9

 5.1 ELECTRICAL SAFETY..... 9

 5.2 APPROVAL TESTS..... 9

6 Reliability 9

 6.1 GENERAL 9

1 General

Fan type	Fan
Rotational direction looking at rotor	clockwise
Airflow direction	Air outlet over struts
Bearing system	Ball bearing
Mounting position	any
Balancing grade	2,5

2 Mechanics**2.1 General**

Width	119,0 mm	
Height	119,0 mm	
Depth	38,0 mm	
Diameter	0,0 mm	
Weight	0,540 kg	
Housing material	Metal	
Impeller material	Metal	
Max. torque when mounted across both mounting flanges	wire outlet corner: 120 Ncm remaining corners: 350 Ncm	
Screw size	ISO 4762 - M4 degreased, without an additional brace and without washer	

2.2 Connections

Electrical connection	Wires	
Length of lead wire	L = 770,0 mm	
Tolerance	+ - 10,0 mm	
Length of tube	see drawing	
Tolerance		
Wire gauge (AWG)	20	
Insulation diameter	1,77 mm	
Plug	see drawing	
Contact	see drawing	

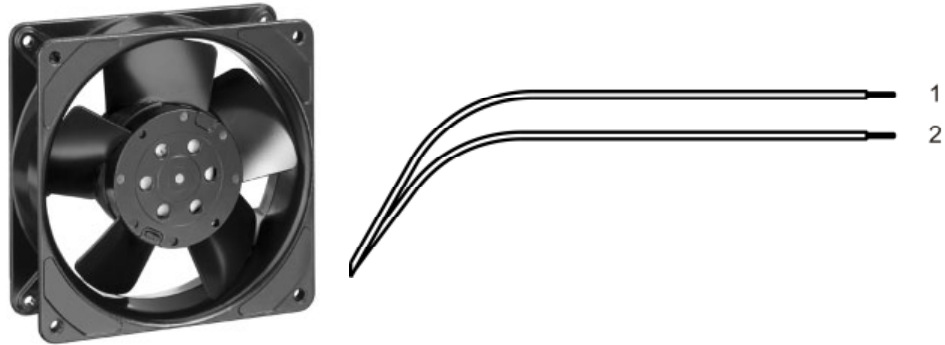

	Colour	Operation
Wire 1	white	L
Wire 2	white	N

3 Operating Data

3.1 Electrical Operating Data

Measurement conditions: Normal air density = 1,2 kg/m³; Temperature 23°C +/- 3°C; Motor axis horizontal; warm-up time before measuring 5 minutes (unless otherwise specified).
In the intake and outlet area should not be any solid obstruction within 0,5 m.

$\Delta p = 0$: corresp. to free air flow (see section 3.4)

I: corresp. to RMS line current

Features	Condition	Symbol	Values	
Frequency	$\Delta p = 0$	f	50 Hz	60 Hz
Nominal voltage	$\Delta p = 0$	U_N	115,0 V +/- 10,0 %	115,0 V +/- 10,0 %
Tolerance				
Power consumption	$\Delta p = 0$	P	19,0 W +/- 10,0 %	17,0 W +/- 10,0 %
Tolerance				
Speed	$\Delta p = 0$	n	2.650 1/min +/- 3,0 %	3.100 1/min +/- 3,0 %
Tolerance				

3.2 Operating Data - Electrical Interface -Output

Tacho type	None
------------	------

3.3 Electrical Features

Locked rotor protection	Impedance
Locked rotor current at Un	

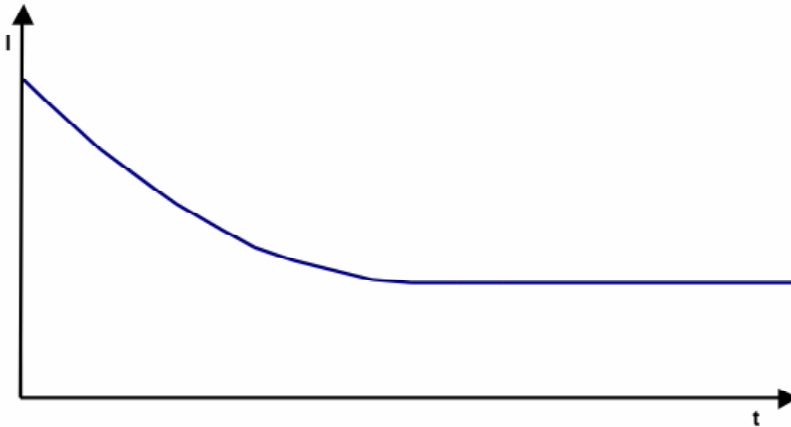

3.4 Aerodynamic

Measurement conditions: Measured with a double chamber intake rig acc. to DIN EN ISO 5801.
 Normal air density = 1,2 kg/m³; Temperature 23°C +/- 3°C;
 In the intake and outlet area should not be any solid obstruction within 0,5 m.
 The information is only valid under the specified test conditions and may be changed by the installation conditions. If there are deviations from the standard test conditions, the characteristic values must be checked under the installed conditions.

a.) Operation condition:
 2.650 1/min at free air flow Frequency: 50 Hz

Max. free-air flow ($\Delta p = 0 / \dot{V} = \text{max.}$)	152,0 m ³ /h
Max. static pressure ($\Delta p = \text{max.} / \dot{V} = 0$)	70 Pa

b.) Operation condition:
 3.100 1/min at free air flow Frequency: 60 Hz

Max. free-air flow ($\Delta p = 0 / \dot{V} = \text{max.}$)	180,0 m ³ /h
Max. static pressure ($\Delta p = \text{max.} / \dot{V} = 0$)	80 Pa

3.5 Sound Data

Measurement conditions: Sound pressure level: 1 Meter distance between microphone and the air intake.
 Sound power level: Acc. to DIN 45635 part 38 (ISO 10302)
 Measured in a semianchoic chamber with a background noise level of $L_p(A) < 5 \text{ dB}(A)$
 For further measurement conditions see section 3.4

a.) Operation condition:

2.650 1/min at free air flow

Frequency: 50 Hz

Optimal operating point	130,0 m ³ /h @ 15 Pa	
Sound power level at the optimal operating point	5,1 bel(A)	
Sound pressure level at free air flow, measured in rubber bands	37,0 dB(A)	

b.) Operation condition:

3.100 1/min at free air flow

Frequency: 60 Hz

Optimal operating point	148,0 m ³ /h @ 20 Pa	
Sound power level at the optimal operating point	5,5 bel(A)	
Sound pressure level at free air flow, measured in rubber bands	42,0 dB(A)	

4 Environment

4.1 General

Min. permitted ambient temperature TU min.	-40 °C / 50 Hz -40 °C / 60 Hz	
Max. permitted ambient temperature TU max.	70 °C / 50 Hz 80 °C / 60 Hz	
Min. permitted storage temperature TL min.	-40 °C	
Max. permitted storage temperature TL max.	100 °C	

4.2 Climatic requirements *)

IP-protection type (certified)	IP 55 **)	
Humidity requirements	humid temperature, cyclic; according to DIN EN 60068-2-38, 10 cycle and condensation water check; according to DIN EN ISO 6270-2, 14 days	
Salt fog requirements	None	

*) Permitted application area:

The product is for the use in partial sheltered rooms or open, roofed areas. Direct exposure to water is allowed provided that this does not prevent the normal operation. Saline ambient conditions must be avoided.

Pollution degree 3 (according DIN EN 60664-1)

It occurs conductive pollution or dry non-conductive pollution which becomes conductive due to condensation.

***) The specification of the IP protection refers to the conditions mentioned in certification of the fan. The above mentioned short description of the protection scope is not final. For detailed information of the respective protection scope and definitions, see certification as well as DIN EN 60529 (protection by housings) and ISO 20653 (for vehicles) with the letter K.

Short description of the IP-protection type:

Solid particle Protection: Protected against dust.

Protection against deliberate contact: Protected against contact to hazardous parts with a wire.

Protection against water: Protected against water jets.

5 Safety

5.1 Electrical Safety

Dielectric strength DIN EN 60950 (VDE 0805) and DIN EN 60335 (VDE 0700) A.) Type test Measuring conditions: After 48h of storage at 95% R.H. and 25°C. No arcing or breakdown is allowed! All connections together to ground. B.) Routine test Measuring conditions: At indoor climate. No arcing or breakdown is allowed! All connections together to ground.	1000 VAC / 1 Min. 1500 VAC / 1 Sec.
Isolation resistance Measuring conditions: After 48h of storage at 95% R.H. and 25°C measured with U=500 VDC for 1 min.	RI > 50 MOhm
clearance / creepage distance	2,0 mm / 1,1 mm
Protection class	I

5.2 Approval Tests

CE	Yes
UL	Yes / UL507, Electric Fans
VDE	Yes / Approval acc. to EN 60950 (VDE 0805) - Information technology equipment
CSA	Yes / C22.2 No. 113 Fans and Ventilators
CCC	Yes / GB 12350 Safety Requirements for small Power Motors

The approval tests are observed to:
U approval max.: 115 V / f: 60 Hz @ TU approval max.: 85 °C

6 Reliability

6.1 General

Life expectancy L10 at TU = 40 °C	37.500 h / 50 Hz	
Life expectancy L10 at TU max.	17.500 h / 50 Hz	

Copying of this document, analyzing it to others and the use or communication of the contents thereof, are prohibited without the express and written permission of the manufacturer of a third party or design.

Schuldrucken nach DIN ISO 9100, ISO 9001, ISO 14001
 Ruler to production metric DIN ISO 9001

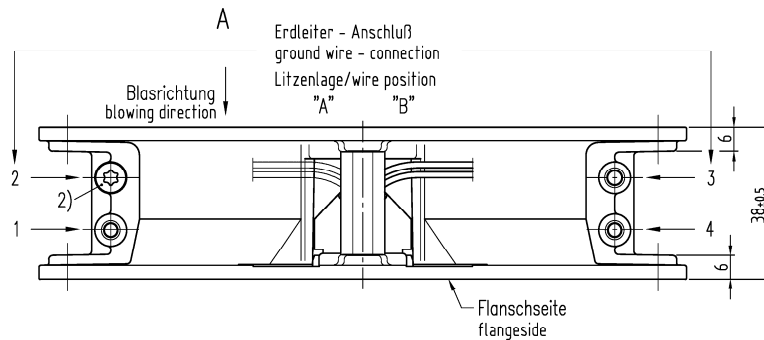
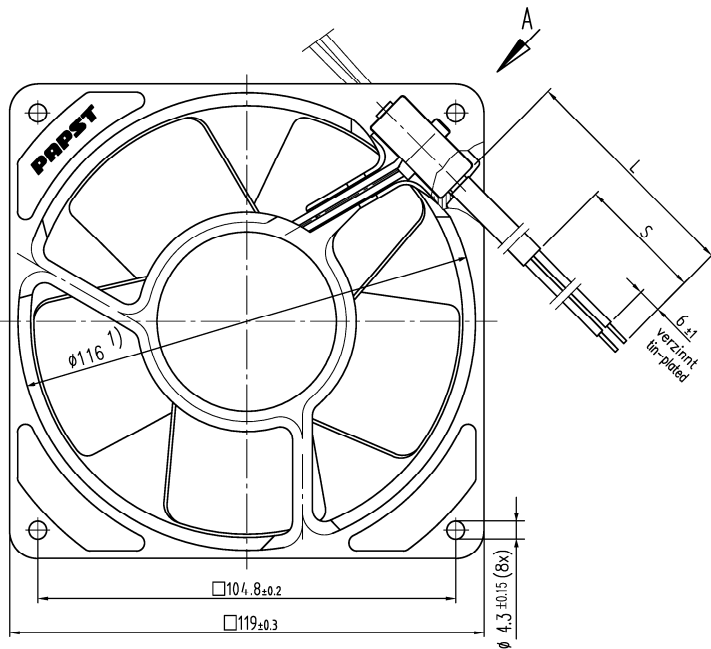

Anzahl und Länge der Litzen sowie
 Schlauchlänge, Litzenlage und Erdleiter-Anschluß s. Spezifikation
 length and number of wires and of tube length,
 wires length and ground wire -connection see design specification

1) Maße für Montagewand
 2) Schraube: Duo-Tapfite nach DIN 7500,
 CM 4x8, Torx

1) dimensions for assembly wall
 2) Screw: Duo-Tapfite to DIN 7500,
 CM 4x8, Torx

Axialspiel bei
 - Kugellagerung (K): 0 (mit Federausgleich)
 - Gleitlagerung (G): 0.1 - 0.6
 - Gleitlagerung (GF): 0 (mit Federausgleich)

axial clearance by
 - ball bearing (K): 0 (with spring compensation)
 - sleeve bearing (G): 0.1 - 0.6
 - sleeve bearing (GF): 0 (with spring compensation)

		ebmpapst		Werkstoff/Material:		Volumen/Volume (mm ³):	
SAP-Status/State	Artid.-Nr./charge-No.	AutCAD-System-Version	CAD-Umgebung/ CAD-Environment			Gewicht/Mass (g):	
		Datum/Date	Name/Name				
		Bearb./ Drawn		Artikel/Title			
Tolerierung/Tolerances		Gepr./ Checked					
Allgemeintoleranzen/Gen. Tolerances		Freig./ Released					
			ebmpapst		Zchg.-Nr. / Drawing-No.:		Ers./Zchg./Replaces:
ebm-papst St. Georgen GmbH & Co. KG					Dokumenttyp/Type of Document	Teildokument Blatt/Page	Index/Index
					Format/Size	Massstab/Scale	

Компания «Океан Электроники» предлагает заключение долгосрочных отношений при поставках импортных электронных компонентов на взаимовыгодных условиях!

Наши преимущества:

- Поставка оригинальных импортных электронных компонентов напрямую с производств Америки, Европы и Азии, а так же с крупнейших складов мира;
- Широкая линейка поставок активных и пассивных импортных электронных компонентов (более 30 млн. наименований);
- Поставка сложных, дефицитных, либо снятых с производства позиций;
- Оперативные сроки поставки под заказ (от 5 рабочих дней);
- Экспресс доставка в любую точку России;
- Помощь Конструкторского Отдела и консультации квалифицированных инженеров;
- Техническая поддержка проекта, помощь в подборе аналогов, поставка прототипов;
- Поставка электронных компонентов под контролем ВП;
- Система менеджмента качества сертифицирована по Международному стандарту ISO 9001;
- При необходимости вся продукция военного и аэрокосмического назначения проходит испытания и сертификацию в лаборатории (по согласованию с заказчиком);
- Поставка специализированных компонентов военного и аэрокосмического уровня качества (Xilinx, Altera, Analog Devices, Intersil, Interpoint, Microsemi, Actel, Aeroflex, Peregrine, VPT, Syfer, Eurofarad, Texas Instruments, MS Kennedy, Miteq, Cobham, E2V, MA-COM, Hittite, Mini-Circuits, General Dynamics и др.);

Компания «Океан Электроники» является официальным дистрибьютором и эксклюзивным представителем в России одного из крупнейших производителей разъемов военного и аэрокосмического назначения «JONHON», а так же официальным дистрибьютором и эксклюзивным представителем в России производителя высокотехнологичных и надежных решений для передачи СВЧ сигналов «FORSTAR».



JONHON

«JONHON» (основан в 1970 г.)

Разъемы специального, военного и аэрокосмического назначения:

(Применяются в военной, авиационной, аэрокосмической, морской, железнодорожной, горно- и нефтедобывающей отраслях промышленности)

«FORSTAR» (основан в 1998 г.)

ВЧ соединители, коаксиальные кабели,
кабельные сборки и микроволновые компоненты:

(Применяются в телекоммуникациях гражданского и специального назначения, в средствах связи, РЛС, а так же военной, авиационной и аэрокосмической отраслях промышленности).



Телефон: 8 (812) 309-75-97 (многоканальный)

Факс: 8 (812) 320-03-32

Электронная почта: ocean@oceanchips.ru

Web: <http://oceanchips.ru/>

Адрес: 198099, г. Санкт-Петербург, ул. Калинина, д. 2, корп. 4, лит. А