



**MCP73871  
Demo Board  
with Voltage Proportional  
Current Control  
User's Guide**

---

**Note the following details of the code protection feature on Microchip devices:**

- Microchip products meet the specification contained in their particular Microchip Data Sheet.
- Microchip believes that its family of products is one of the most secure families of its kind on the market today, when used in the intended manner and under normal conditions.
- There are dishonest and possibly illegal methods used to breach the code protection feature. All of these methods, to our knowledge, require using the Microchip products in a manner outside the operating specifications contained in Microchip's Data Sheets. Most likely, the person doing so is engaged in theft of intellectual property.
- Microchip is willing to work with the customer who is concerned about the integrity of their code.
- Neither Microchip nor any other semiconductor manufacturer can guarantee the security of their code. Code protection does not mean that we are guaranteeing the product as "unbreakable."

Code protection is constantly evolving. We at Microchip are committed to continuously improving the code protection features of our products. Attempts to break Microchip's code protection feature may be a violation of the Digital Millennium Copyright Act. If such acts allow unauthorized access to your software or other copyrighted work, you may have a right to sue for relief under that Act.

---

Information contained in this publication regarding device applications and the like is provided only for your convenience and may be superseded by updates. It is your responsibility to ensure that your application meets with your specifications. MICROCHIP MAKES NO REPRESENTATIONS OR WARRANTIES OF ANY KIND WHETHER EXPRESS OR IMPLIED, WRITTEN OR ORAL, STATUTORY OR OTHERWISE, RELATED TO THE INFORMATION, INCLUDING BUT NOT LIMITED TO ITS CONDITION, QUALITY, PERFORMANCE, MERCHANTABILITY OR FITNESS FOR PURPOSE. Microchip disclaims all liability arising from this information and its use. Use of Microchip devices in life support and/or safety applications is entirely at the buyer's risk, and the buyer agrees to defend, indemnify and hold harmless Microchip from any and all damages, claims, suits, or expenses resulting from such use. No licenses are conveyed, implicitly or otherwise, under any Microchip intellectual property rights.

**Trademarks**

The Microchip name and logo, the Microchip logo, dsPIC, KEELOQ, KEELOQ logo, MPLAB, PIC, PICmicro, PICSTART, rPIC and UNI/O are registered trademarks of Microchip Technology Incorporated in the U.S.A. and other countries.

FilterLab, Hampshire, HI-TECH C, Linear Active Thermistor, MXDEV, MXLAB, SEEVAL and The Embedded Control Solutions Company are registered trademarks of Microchip Technology Incorporated in the U.S.A.

Analog-for-the-Digital Age, Application Maestro, CodeGuard, dsPICDEM, dsPICDEM.net, dsPICworks, dsSPEAK, ECAN, ECONOMONITOR, FanSense, HI-TIDE, In-Circuit Serial Programming, ICSP, Mindi, MiWi, MPASM, MPLAB Certified logo, MPLIB, MPLINK, mTouch, Octopus, Omniscient Code Generation, PICC, PICC-18, PICDEM, PICDEM.net, PICKit, PICtail, PIC<sup>32</sup> logo, REAL ICE, rLAB, Select Mode, Total Endurance, TSHARC, UniWinDriver, WiperLock and ZENA are trademarks of Microchip Technology Incorporated in the U.S.A. and other countries.

SQTP is a service mark of Microchip Technology Incorporated in the U.S.A.

All other trademarks mentioned herein are property of their respective companies.

© 2009, Microchip Technology Incorporated, Printed in the U.S.A., All Rights Reserved.

 Printed on recycled paper.

**QUALITY MANAGEMENT SYSTEM**  
**CERTIFIED BY DNV**  
**== ISO/TS 16949:2002 ==**

*Microchip received ISO/TS-16949:2002 certification for its worldwide headquarters, design and wafer fabrication facilities in Chandler and Tempe, Arizona; Gresham, Oregon and design centers in California and India. The Company's quality system processes and procedures are for its PIC<sup>®</sup> MCUs and dsPIC<sup>®</sup> DSCs, KEELOQ<sup>®</sup> code hopping devices, Serial EEPROMs, microperipherals, nonvolatile memory and analog products. In addition, Microchip's quality system for the design and manufacture of development systems is ISO 9001:2000 certified.*



# MCP73871 DEMO BOARD WITH VOLTAGE PROPORTIONAL CURRENT CONTROL USER'S GUIDE

---

---

## Table of Contents

---

---

<b>Preface</b> .....	<b>1</b>
Introduction.....	1
Document Layout .....	1
Conventions Used in this Guide .....	2
Recommended Reading.....	3
The Microchip Web Site .....	3
Customer Support .....	3
Document Revision History .....	3
<b>Chapter 1. Product Overview</b>	
1.1 Introduction .....	5
1.2 What is the MCP73871 Demo Board with Voltage Proportional Current Control? .....	6
1.3 What the MCP73871 Demo Board with Voltage Proportional Current Control kit Includes? .....	6
<b>Chapter 2. Installation and Operation</b>	
2.1 Introduction .....	7
2.2 Features .....	7
2.3 Getting Started .....	8
<b>Appendix A. Schematic and Layouts</b>	
A.1 Introduction .....	13
A.2 Board – Schematic .....	14
A.3 Board – Top Silk and Pads .....	15
A.4 Board – Top Metal Layer .....	16
A.5 Board – Bottom Layer .....	17
<b>Appendix B. Bill of Materials (BOM)</b>	
<b>Worldwide Sales and Service</b> .....	<b>20</b>

NOTES:



# MCP73871 DEMO BOARD WITH VOLTAGE PROPORTIONAL CURRENT CONTROL USER'S GUIDE

## Preface

### NOTICE TO CUSTOMERS

All documentation becomes dated, and this manual is no exception. Microchip tools and documentation are constantly evolving to meet customer needs, so some actual dialogs and/or tool descriptions may differ from those in this document. Please refer to our web site ([www.microchip.com](http://www.microchip.com)) to obtain the latest documentation available.

Documents are identified with a "DS" number. This number is located on the bottom of each page, in front of the page number. The numbering convention for the DS number is "DSXXXXA", where "XXXX" is the document number and "A" is the revision level of the document.

For the most up-to-date information on development tools, see the MPLAB® IDE on-line help. Select the Help menu, and then Topics to open a list of available on-line help files.

## INTRODUCTION

This chapter contains general information that will be useful to know before using the MCP73871 Demo Board with Voltage Proportional Current Control. Items discussed in this chapter include:

- Document Layout
- Conventions Used in this Guide
- Recommended Reading
- The Microchip Web Site
- Customer Support
- Document Revision History

## DOCUMENT LAYOUT

This document describes how to use the MCP73871 Demo Board with Voltage Proportional Current Control as a linear Li-Ion battery charge controller that can share a load. The manual layout is as follows:

- **Chapter 1. "Product Overview"** – Important information about the MCP73871 Demo Board with Voltage Proportional Current Control.
- **Chapter 2. "Installation and Operation"** – Includes instructions on how to get started with this user's guide and a description of the user's guide.
- **Appendix A. "Schematic and Layouts"** – Shows the schematic and layout diagrams for the MCP73871 Demo Board with Voltage Proportional Current Control.
- **Appendix B. "Bill of Materials (BOM)"** – Lists the parts used to build the MCP73871 Demo Board with Voltage Proportional Current Control.

## CONVENTIONS USED IN THIS GUIDE

This manual uses the following documentation conventions:

### DOCUMENTATION CONVENTIONS

Description	Represents	Examples
<b>Arial font:</b>		
Italic characters	Referenced books	<i>MPLAB<sup>®</sup> IDE User's Guide</i>
	Emphasized text	...is the <i>only</i> compiler...
Initial caps	A window	the Output window
	A dialog	the Settings dialog
	A menu selection	select Enable Programmer
Quotes	A field name in a window or dialog	"Save project before build"
Underlined, italic text with right angle bracket	A menu path	<u><i>File&gt;Save</i></u>
Bold characters	A dialog button	Click <b>OK</b>
	A tab	Click the <b>Power</b> tab
N'Rnnnn	A number in verilog format, where N is the total number of digits, R is the radix and n is a digit.	4'b0010, 2'hF1
Text in angle brackets < >	A key on the keyboard	Press <Enter>, <F1>
<b>Courier New font:</b>		
Plain Courier New	Sample source code	#define START
	Filenames	autoexec.bat
	File paths	c:\mcc18\h
	Keywords	_asm, _endasm, static
	Command-line options	-Opa+, -Opa-
	Bit values	0, 1
	Constants	0xFF, 'A'
Italic Courier New	A variable argument	<i>file.o</i> , where <i>file</i> can be any valid filename
Square brackets [ ]	Optional arguments	mcc18 [options] <i>file</i> [options]
Curly brackets and pipe character: {   }	Choice of mutually exclusive arguments; an OR selection	errorlevel {0 1}
Ellipses...	Replaces repeated text	var_name [, var_name...]
	Represents code supplied by user	void main (void) { ... }

## RECOMMENDED READING

This user's guide describes how to use MCP73871 Demo Board with Voltage Proportional Current Control. Other useful documents are listed below. The following Microchip documents are available and recommended as supplemental reference resources.

- **MCP73871 Data Sheet - “Stand-Alone System Load Sharing and Li-Ion / Li-Polymer Battery Charge Management Controller”, DS22090**

This data sheet provides detailed information regarding the MCP73871 product family.

## THE MICROCHIP WEB SITE

Microchip provides online support via our web site at [www.microchip.com](http://www.microchip.com). This web site is used as a means to make files and information easily available to customers. Accessible by using your favorite Internet browser, the web site contains the following information:

- **Product Support** – Data sheets and errata, application notes and sample programs, design resources, user's guides and hardware support documents, latest software releases and archived software
- **General Technical Support** – Frequently Asked Questions (FAQs), technical support requests, online discussion groups, Microchip consultant program member listing
- **Business of Microchip** – Product selector and ordering guides, latest Microchip press releases, listing of seminars and events, listings of Microchip sales offices, distributors and factory representatives

## CUSTOMER SUPPORT

Users of Microchip products can receive assistance through several channels:

- Distributor or Representative
- Local Sales Office
- Field Application Engineer (FAE)
- Technical Support

Customers should contact their distributor, representative or field application engineer (FAE) for support. Local sales offices are also available to help customers. A listing of sales offices and locations is included in the back of this document.

Technical support is available through the web site at: <http://support.microchip.com>.

## DOCUMENT REVISION HISTORY

### Revision B (November 2009)

Initial Release of this Document.

- Updated **Section 2.2 “Features”** with information on the Voltage Proportional Current Control Input Voltage.
- Added footnote to Table 2-1.
- Updated **Section 2.3.3 “Voltage Proportional Charge Control (VPCC) Function”**.
- Added **Section 2.3.3.1 “Example”**.

### Revision A (April 2009)

- Initial Release of this Document.



## Chapter 1. Product Overview

### 1.1 INTRODUCTION

The MCP73871 Demo Board with Voltage Proportional Current Control is designed to demonstrate Microchip's stand-alone linear Li-Ion battery charger with system power path and load sharing management control solution. The MCP73871 integrates the required elements to meet design challenges when developing new Li-Ion / Li-Polymer batteries powered products.

The MCP73871 requires minimum external components to power the system load and charge single cell Li-Ion batteries independently. When input power is absent or insufficient, the Li-Ion battery becomes the primary power source and supports the required system load current. The MCP73871 Demo Board with Voltage Proportional Current Control feature added is developed to assist engineers in reducing product design cycle and time by utilizing Microchip's favorite stand-alone Li-Ion battery charger and system load sharing management controller.

This chapter provides an overview of the MCP73871 Demo Board with Voltage Proportional Current Control and covers the following topics:

- What is the MCP73871 Demo Board with Voltage Proportional Current Control?
- What the MCP73871 Demo Board with Voltage Proportional Current Control Kit includes?

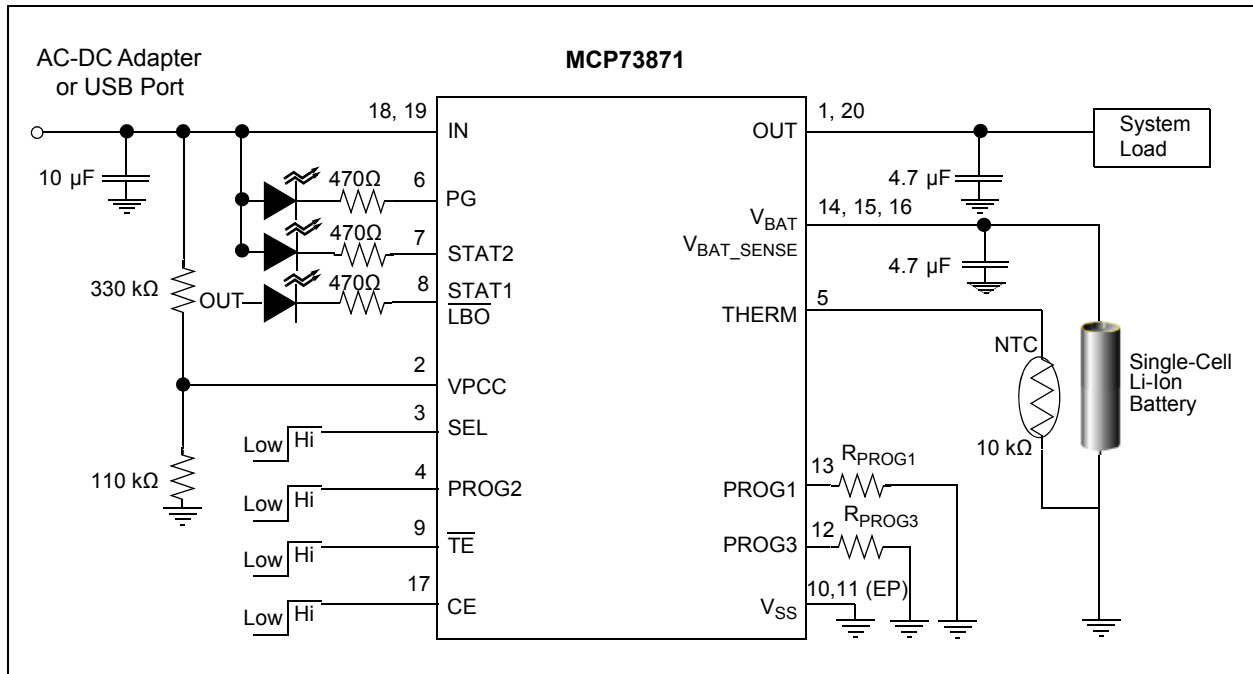

**FIGURE 1-1:** MCP73871 With System Power Path and Voltage Proportional Current Control (VPCC) Management Typical Application.

## 1.2 WHAT IS THE MCP73871 DEMO BOARD WITH VOLTAGE PROPORTIONAL CURRENT CONTROL?

The MCP73871 Demo Board with Voltage Proportional Current Control demonstrates the features of Microchip's MCP73871 "Stand-Alone System Load Sharing and Li-Ion / Li-Poly Battery Charge Management Controller". The MCP73871 Demo Board with Voltage Proportional Current Control is designed to deliver minimum 1.5A total current to system load and to a single cell Li-Ion battery at 4.2V preset voltage regulation (4.1V, 4.35V and 4.4V options are also available for MCP73871). The MCP73871 Demo Board with Voltage Proportional Current Control has one dip switch (S1) with four poles to control input current limits, enable charge timer and enable charging. The first switch decides the input power source between AC-DC wall adapter and USB port (AC/USB). The second switch of S1 determines the 500 mA high-power USB port or the 100 mA low-power USB port (High/Low), if the first switch of S1 is enabled (ON). The input current limit is governed by the USB specification when selecting USB on S1 switch.

The maximum fast current when AC is selected on S1 is programmed by the resistor  $R_{PROG1}$  at 1A, and the termination current is set at 100 mA by  $R_{PROG3}$  (see Figure 1-1).

The MCP73871 Demo Board with Voltage Proportional Current Control offers three status LED (for charge status outputs and a power-good indicator).

**Note:** Refer to Table 2-1 for charge status outputs and Figure 2-1 for charge current setups.

The MCP73871 Demo Board with Voltage Proportional Current Control comes with a factory preset low-battery indicator (LBO) when input is absent. The preset value is 3.2V and STAT1 LED (Green) will turn ON if the battery voltage is below the threshold voltage.

The MCP73871 Demo Board with Voltage Proportional Current Control is designed to cover all the features of the MCP73871 device. A thermistor can be added at test points TP6 and TP7, but resistor R6 must be removed (see the **A.2 "Board – Schematic"**). The board layout easily permit to change the two programmable resistors:  $R_{PROG1}$  and  $R_{PROG3}$ .

## 1.3 WHAT THE MCP73871 DEMO BOARD WITH VOLTAGE PROPORTIONAL CURRENT CONTROL KIT INCLUDES?

This MCP73871 Demo Board with Voltage Proportional Current Control kit includes:

- One MCP73871 Demo Board with Voltage Proportional Current Control, 102-00244
- Important Information "Read First"

---

---

## Chapter 2. Installation and Operation

---

---

### 2.1 INTRODUCTION

The MCP73871 Demo Board with Voltage Proportional Current Control demonstrates Microchip's standalone linear Li-Ion battery charger with system power path and load sharing management control solution. The system load is also powered by the Li-Ion battery when the input power is disconnected. A number of device options allow the MCP73871 to be utilized in a variety of applications. Please refer to the MCP73871 Data Sheet (DS22090) and/or contact local Microchip supports for additional device options.

Typical applications for the reference design are in Smart Phones, PDA, Portable Media Players, MP3 Players, Digital Cameras, Handheld Medical devices, Bluetooth headsets, Ultra-Mobile PC and Portable Communicators.

### 2.2 FEATURES

The MCP73871 Demo Board with Voltage Proportional Current Control has the following features:

- Integrated System Load Sharing
- Voltage Proportional Current Control (VPCC) Input voltage: 5.5V with  $\pm 0.5V$  tolerance (additional information available in the MCP73871 Data Sheet)
- Input Current Limit Control hardware selected (typical 1650 mA, USB-High maximum 500 mA, and USB-Low maximum 100 mA)
- Three LEDs to indicate charge status, low battery and power good signal
- Preset Li-Ion battery charge voltage:  $4.2V \pm 0.5\%$
- Temperature monitoring is disabled by default, but can be enabled to use with a NTC thermister (tied at TP6 and TP7 and removing R6)
- Factory preset 0.1C preconditioning current of deeply depleted cells
- Factory preset Safety Timer with Timer Enable feature (by S1 switch)
- Constant Current/Constant Voltage (CC/CV) charge algorithm
- Resistor programmed maximum charge current ( $R_{PROG1}$ ): 1A
- Resistor programmed termination set point ( $R_{PROG3}$ ): 100 mA
- Automatic Charge Termination
- Automatic Recharge
- Internal Thermal Regulation
- Exposed Pad with extra via underneath for better heat dissipations

## 2.3 GETTING STARTED

The MCP73871 Demo Board with Voltage Proportional Current Control is fully assembled and tested for charging a single-cell Li-Ion or Li-Polymer battery with or without system load.

### 2.3.1 Power Input and Output Connection

#### 2.3.1.1 POWERING THE MCP73871 DEMO BOARD WITH VOLTAGE PROPORTIONAL CURRENT CONTROL

1. Connect the positive battery terminal to  $V_{BAT+}$  (TP4) and negative battery terminal to GND (TP1 or TP5).
2. Connect the 5V – 6V DC power supply Negative Terminal to GND (TP1 or TP5).
3. Connect the 5V – 6V DC power supply Positive Terminal to  $V_{DD}$  (TP2).
4. Connect positive of load to OUT (TP3) on the board and negative of load to GND (TP1 or TP5). The system load can be a power resistor or E-Load.
5. The maximum current that system load requires should not violate the specification of Li-Ion battery manufacturer (typical at 1C or less) or 1A for safety and performance concerns.
6. You should initiate the battery charging cycle when turning CE switch of S1 OFF. Turning the CE switch ON disables the Li-Ion battery charger function.
7. The S1 switch #1 in OFF position (SEL - “AC-DC”) allows maximum input current of 1.8A to support both system load and Li-Ion battery charger at 1000 mA fast charge current rate.
8. The S1 switch #1 in ON position (SEL - “USB”) limits the input current to meet USB specifications.
9. If switch SEL is in ON position (PROG2), the user has two options for switch #2:
  - OFF - limits the total input current to 500 mA
  - ON - for maximum input current at 100 mA.

- |   |
|---|
| <p><b>Note 1:</b> For setup/configuration follow the information in Table 2-2.</p> <p><b>2:</b> Fast Charge Current and Termination Current can be easily programmed with various resistors based on Figure 2-1.</p> <p><b>3:</b> The Li-Ion battery pack can be replaced with test circuit or electronic load that can sink current with DC power supply. Refer to Figure 2-2 for details.</p> |
|---|

10. If DC power is removed, the load should be supported by the Li-Ion battery.

### 2.3.2 Programming Resistors

The resistors that connected at  $R_{PROG1}$  and  $R_{PROG3}$  pins select the maximum charge current in constant current mode from ac-dc adapter and termination current, respectively. The relationship between fast charge current and value of  $R_{PROG1}$  resistor is illustrated in Figure 2-1. The correspondence of  $R_{PROG1}$  on MCP73871 Demo Board with Voltage Proportional Current Control is  $R_1$ . The default value is 1 k $\Omega$ , which sets the maximum charge current at 1A.

For  $R_{PROG3}$ , the correspondent resistor is  $R_2$ . A 10 k $\Omega$  resistor sets the charge termination current at 100 mA and a 100 k $\Omega$  value results a 10 mA termination point. Read carefully the additional information on the schematic in **A.2 “Board – Schematic”**. The boards comes with  $R_2 = 10$  k $\Omega$ .

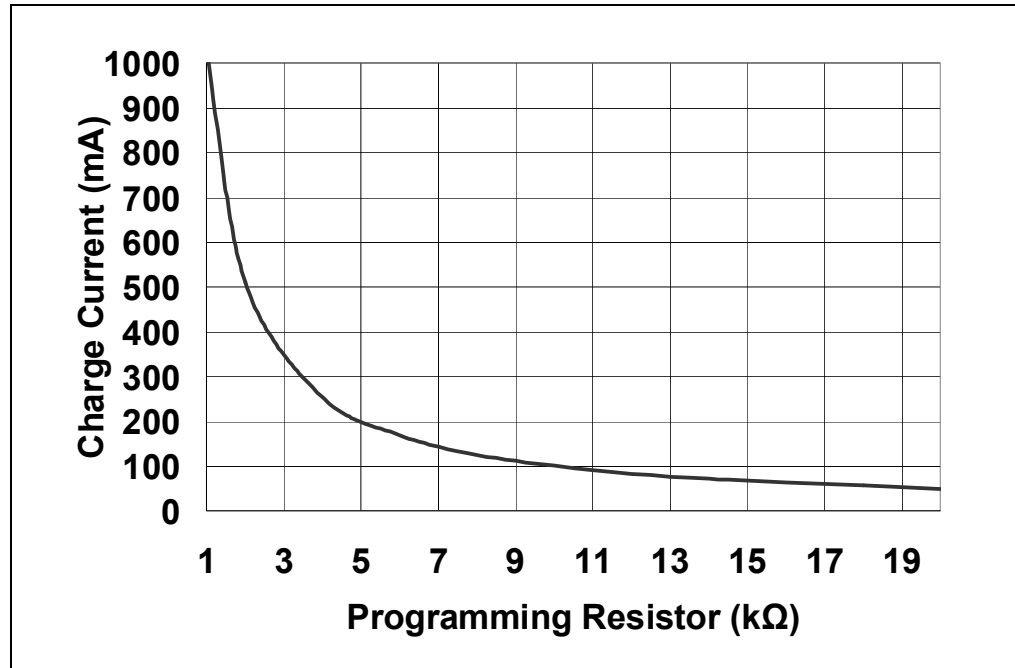

**FIGURE 2-1:** MCP73871 Charge Current ( $I_{OUT}$ ) vs. Programming Resistor ( $R_{PROG1}$ ).

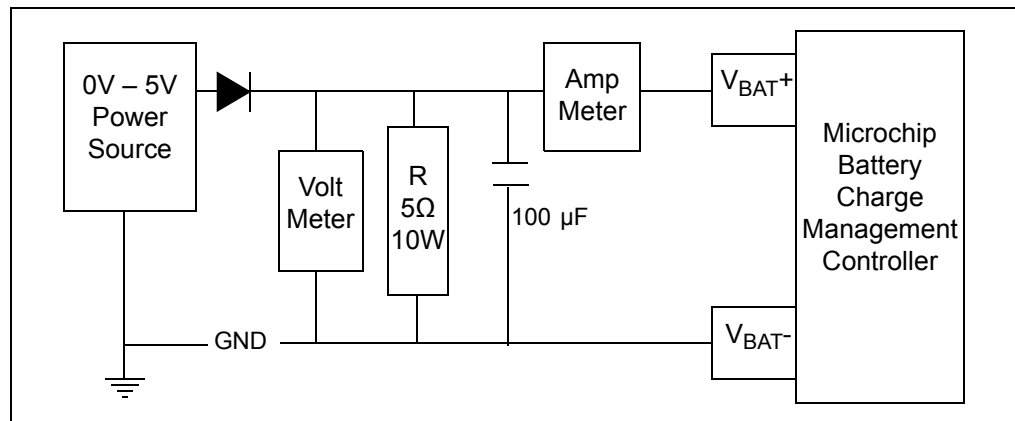

**FIGURE 2-2:** Simulated Battery Load.

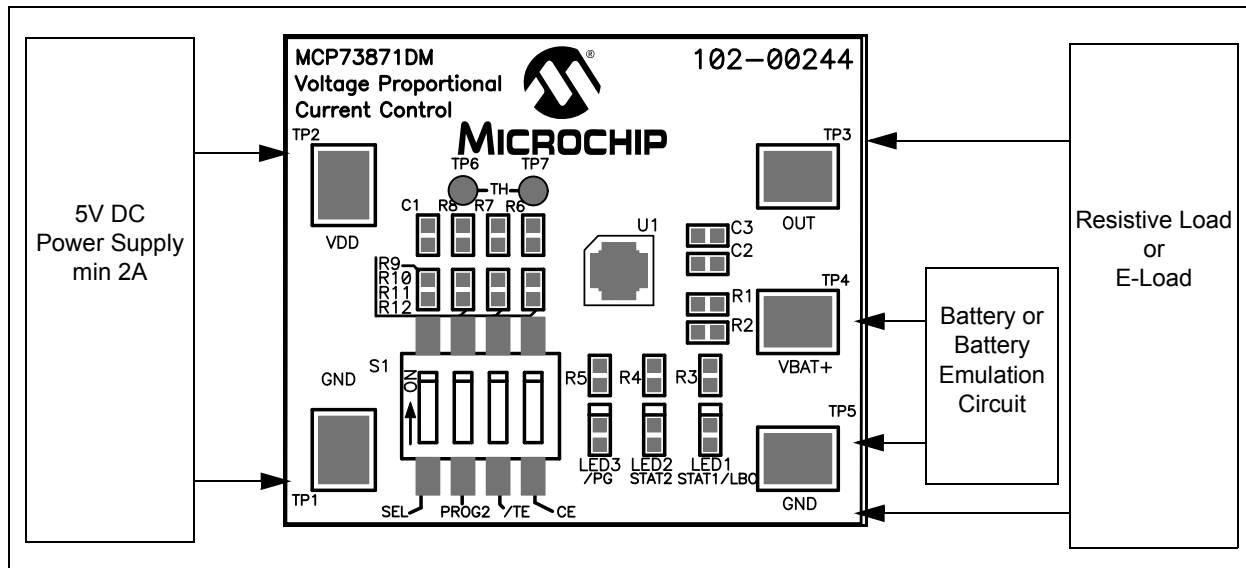

**FIGURE 2-3:** MCP73871 Top Board and Application Circuit.

**TABLE 2-1: MCP73871 CHARGE STATUS OUTPUTS**

Charge Cycle State	STAT1 (Green)	STAT2 (Red)	PG (Blue)
Shutdown	OFF	OFF	OFF
Standby	OFF	OFF	ON
Charge in Progress	ON	OFF	ON
Charge Complete (EOC)	OFF	ON	ON
Temperature Fault	ON	ON	ON
Timer Fault	ON	ON	ON
Low Battery Indicator (LBO)	ON	OFF	OFF
No Battery Present	OFF	OFF	ON
No Input Power	OFF	OFF	OFF

**Note:** LED Status Outputs are given for the battery connected at  $V_{BAT}$  and GND.

**TABLE 2-2: MCP73871 DEMO BOARD DIP SWITCH CONFIGURATION**

Switch # / Name	State / Function		Observations
	OFF	ON	
1 / SEL	AC-DC Adapter	Power from USB	—
2 / PROG2	USB maximum 500 mA	USB max 100 mA	Only if SEL is ON
3 / TE	Timer Enable OFF	Timer Enable activated	Factory preset at 4h, 6h and 8h
4 / CE	Charge is enabled	Charge function OFF	CE = Chip Enable

## 2.3.3 Voltage Proportional Charge Control (VPCC) Function

If the input voltage drops to a preset value, determined by the threshold established at the VPCC input (1.23V at pin #2), due to a limited amount of input current or input source impedance, the battery charging current is reduced. The VPCC control tries to reach a steady state condition where the system load has priority and the battery is charged with the remaining current. Therefore, if the system demands more current than the input can provide, the MCP73871 changes its status and the battery is able to supplement the input current to the system load.

The VPCC function sustains the system load as its highest priority. It does this by reducing the noncritical charge current while maintaining the maximum power output of the adapter. Further demand from the system is supported by the battery, if possible. The VPCC feature functions are identical for USB port or AC-DC adapter inputs. This feature can be disabled by removing resistor R<sub>7</sub> and replacing R<sub>8</sub> with a zero ohms 0603 resistor.

The demo board is designed to operate with 5.5V with +/-0.5V tolerance input voltage, by setting accordingly the voltage on VPCC pin by R<sub>7</sub> and R<sub>8</sub> resistors (see **A.2 “Board – Schematic”**). Additional information on the configuration of the VPCC function is available in the MCP73871 Data Sheet.

### 2.3.3.1 EXAMPLE

A system is designed with a 5.0V rated DC power supply with ±0.5V tolerance. The worst condition of 4.5V is selected, which is used to calculate the VPCC supply voltage with divider. The voltage divider equation is shown below:

$$VPCC = \frac{R7}{R7 + R8} \times V_{DDmin}$$

$$1.23V = \frac{110k}{110k + R8} \times 4.5V$$

$$R8 = 292.43k\Omega$$

The calculated R<sub>8</sub> equals to 292.43 kΩ when 110 kΩ is selected for R<sub>7</sub>. The 294 kΩ resistor is selected for R<sub>8</sub> to build the voltage divider for VPCC pin.

Figure 2-4 illustrates the influence of various input voltages.

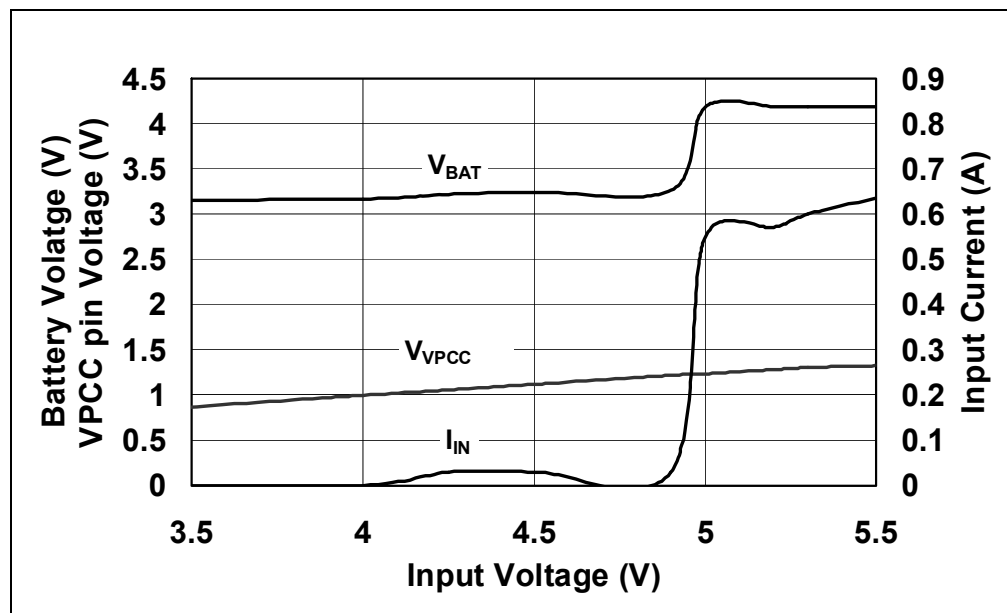
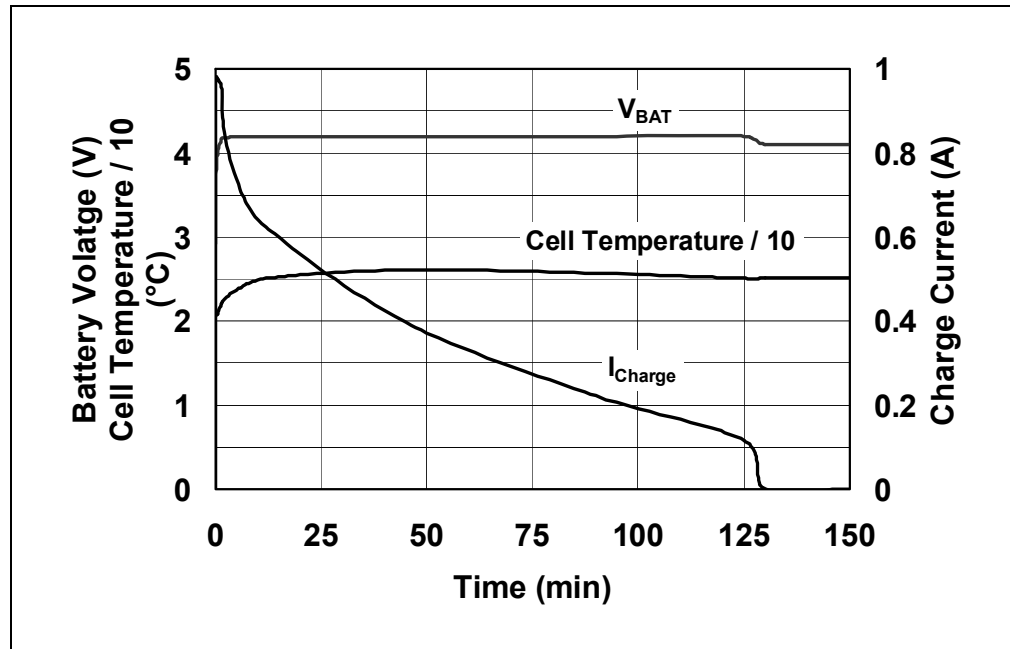

**FIGURE 2-4:** Input and Output Parameters when Input Voltage is Variable, from 2.5V to 5.5V. See the Influence of VPCC Pin.

### 2.3.4 Temperature Monitoring Option

The MCP73871 device monitors continuously the battery temperature during a charge cycle by measuring the voltage between the THERM and  $V_{SS}$  pins. An internal current source provides the bias for most common 10 k $\Omega$  negative-temperature coefficient thermistors (NTC). The MCP73871 device compares the voltage at the THERM pin to factory set thresholds of 1.24V and 0.25V, typically. Once a voltage outside the thresholds is detected during a charge cycle, the MCP73871 device immediately suspends the charge cycle, by turning off the charge and holding the timer value. The charge cycle resumes when the voltage at the THERM pin returns to the normal range.

To activate this feature, remove R6 resistor and connect a 10 k $\Omega$  NTC thermistor to TP6 and TP7 test points.



**FIGURE 2-5:** MCP73871 Charge Profile in Constant Voltage Mode for a 900 mAh Li-Ion Cell.





# MCP73871 DEMO BOARD WITH VOLTAGE PROPORTIONAL CURRENT CONTROL USER'S GUIDE

---

---

## Appendix A. Schematic and Layouts

---

---

### A.1 INTRODUCTION

This appendix contains the following schematics and layouts for the MCP73871 Demo Board with Voltage Proportional Current Control:

- Board – Schematic
- Board – Top Silk and Pads
- Board – Top Metal Layer
- Board – Bottom Layer



## A.3 BOARD – TOP SILK AND PADS

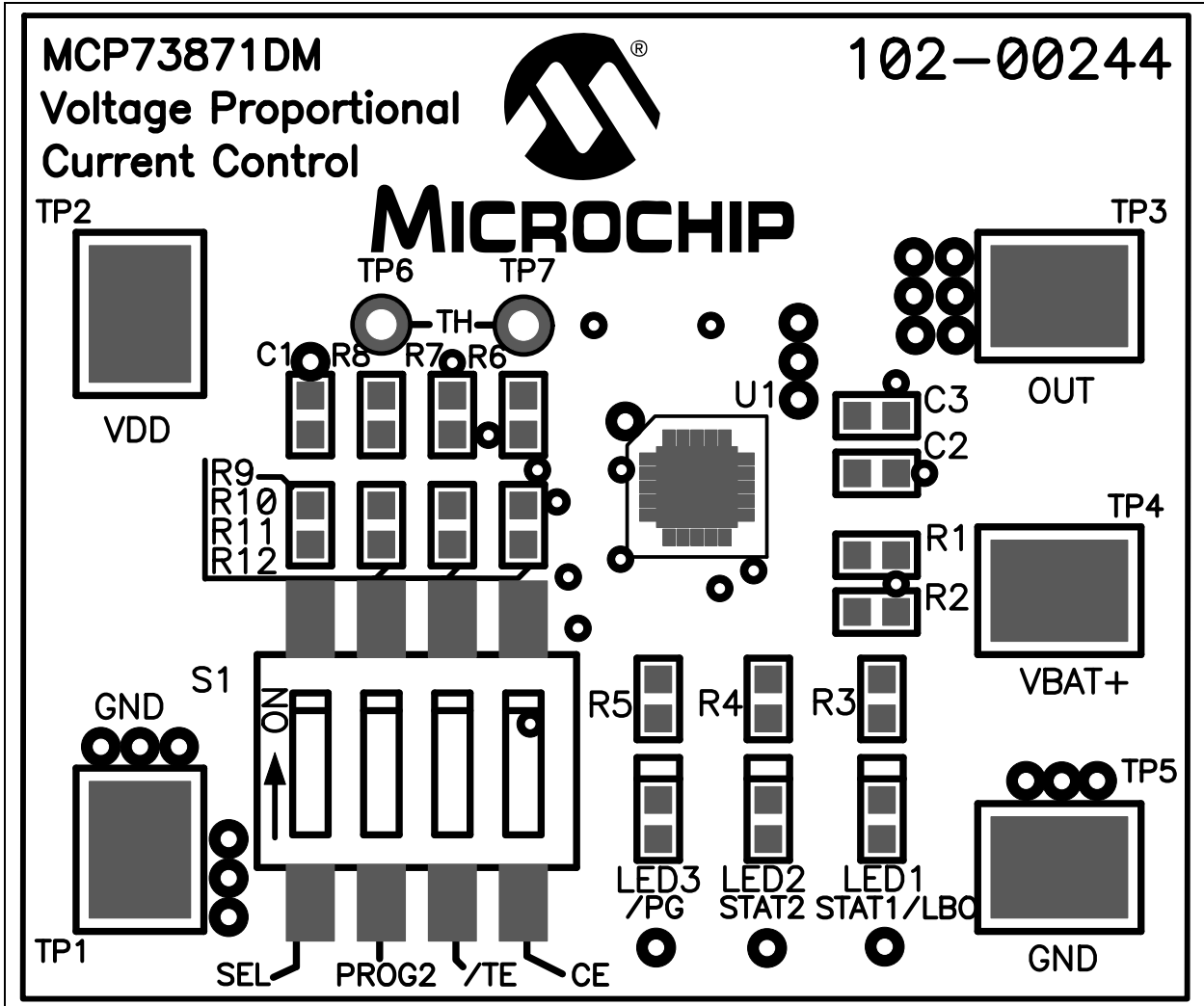

A.4 BOARD – TOP METAL LAYER

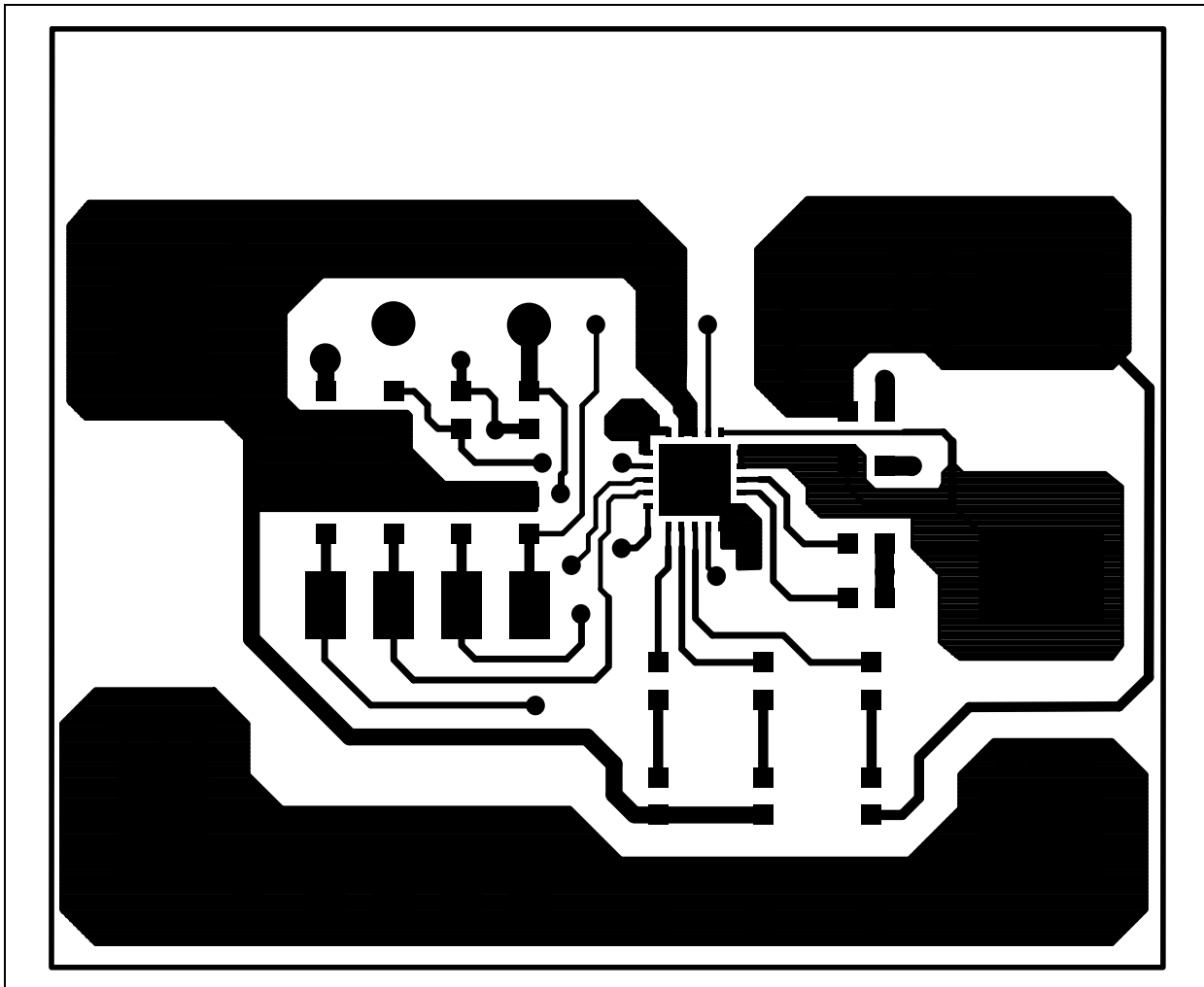

## A.5 BOARD – BOTTOM LAYER

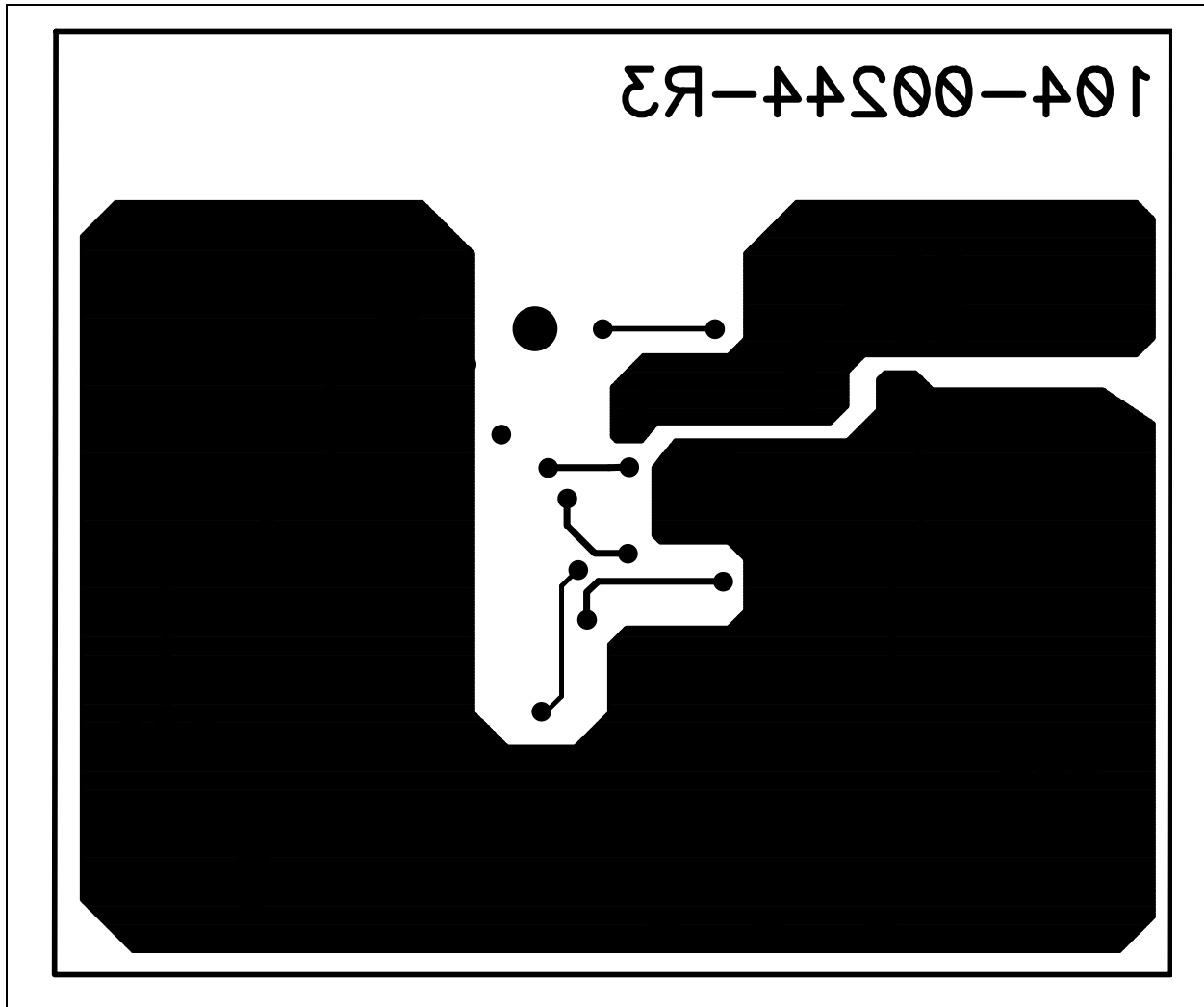

**NOTES:**



# MCP73871 DEMO BOARD WITH VOLTAGE PROPORTIONAL CURRENT CONTROL USER'S GUIDE

## Appendix B. Bill of Materials (BOM)

**TABLE B-1: BILL OF MATERIALS (BOM)**

Qty	Reference	Description	Manufacturer	Part Number
3	C1, C2, C3	CAP CERAMIC 4.7 uF 10 X5R 0603	Taiyo Yuden®	LMK107BJ475KA-T
1	LED1	True Green Water Clear 0603 SMD LED	Para Light USA	L-C191LGCT-U1
1	LED2	Super Red Water Clear 0603 SMD LED	Para Light USA	L-C191KRCT-U1
1	LED3	Blue Water Clear 0603 SMD LED	Para Light USA	L-C191LBCT-U1
1	PCB	RoHS Compliant Bare PCB, MCP73871 Demo Board w/ Voltage Proportional Current Control	Advanced Circuits	104-00244
4	R1, R3, R4, R5	RES 1K OHM 1/10W 1% 0603 SMD	Panasonic® - ECG	ERJ-3EKF1001V
2	R2, R6	RES 10K OHM 1/10W 1% 0603 SMD	Panasonic - ECG	ERJ-3EKF1002V
5	R7, R9, R10, R11, R12	RES 110K OHM 1/10W 1% 0603 SMD	Panasonic - ECG	ERJ-3EKF1103V
1	R8	RES 330K OHM 1/10W 5% 0603 SMD	Panasonic - ECG	ERJ-3GEYJ334V
1	S1	SWITCH DIP TAPE SEALED 4POS SMD	C&K Components	SDA04H0SB
5	TP1, TP2, TP3, TP4, TP5	PC Test Point Compact SMT	Keystone Electronics®	5016
1	U1	Stand-Alone System Load Sharing and Li-Ion / Li-Polymer Battery Charge Management Controller	Microchip Technology Inc.	MCP73871-2CCI/ML
4	Bump	BUMPON HEMISPHERE .44X.20 WHITE	3M	SJ5003-9-ND

**Note 1:** The components listed in this Bill of Materials are representative of the PCB assembly. The released BOM used in manufacturing uses all RoHS-compliant components.



## WORLDWIDE SALES AND SERVICE

### AMERICAS

#### Corporate Office

2355 West Chandler Blvd.  
Chandler, AZ 85224-6199  
Tel: 480-792-7200  
Fax: 480-792-7277  
Technical Support:  
<http://support.microchip.com>  
Web Address:  
[www.microchip.com](http://www.microchip.com)

#### Atlanta

Duluth, GA  
Tel: 678-957-9614  
Fax: 678-957-1455

#### Boston

Westborough, MA  
Tel: 774-760-0087  
Fax: 774-760-0088

#### Chicago

Itasca, IL  
Tel: 630-285-0071  
Fax: 630-285-0075

#### Cleveland

Independence, OH  
Tel: 216-447-0464  
Fax: 216-447-0643

#### Dallas

Addison, TX  
Tel: 972-818-7423  
Fax: 972-818-2924

#### Detroit

Farmington Hills, MI  
Tel: 248-538-2250  
Fax: 248-538-2260

#### Kokomo

Kokomo, IN  
Tel: 765-864-8360  
Fax: 765-864-8387

#### Los Angeles

Mission Viejo, CA  
Tel: 949-462-9523  
Fax: 949-462-9608

#### Santa Clara

Santa Clara, CA  
Tel: 408-961-6444  
Fax: 408-961-6445

#### Toronto

Mississauga, Ontario,  
Canada  
Tel: 905-673-0699  
Fax: 905-673-6509

### ASIA/PACIFIC

#### Asia Pacific Office

Suites 3707-14, 37th Floor  
Tower 6, The Gateway  
Harbour City, Kowloon  
Hong Kong  
Tel: 852-2401-1200  
Fax: 852-2401-3431

#### Australia - Sydney

Tel: 61-2-9868-6733  
Fax: 61-2-9868-6755

#### China - Beijing

Tel: 86-10-8528-2100  
Fax: 86-10-8528-2104

#### China - Chengdu

Tel: 86-28-8665-5511  
Fax: 86-28-8665-7889

#### China - Hong Kong SAR

Tel: 852-2401-1200  
Fax: 852-2401-3431

#### China - Nanjing

Tel: 86-25-8473-2460  
Fax: 86-25-8473-2470

#### China - Qingdao

Tel: 86-532-8502-7355  
Fax: 86-532-8502-7205

#### China - Shanghai

Tel: 86-21-5407-5533  
Fax: 86-21-5407-5066

#### China - Shenyang

Tel: 86-24-2334-2829  
Fax: 86-24-2334-2393

#### China - Shenzhen

Tel: 86-755-8203-2660  
Fax: 86-755-8203-1760

#### China - Wuhan

Tel: 86-27-5980-5300  
Fax: 86-27-5980-5118

#### China - Xiamen

Tel: 86-592-2388138  
Fax: 86-592-2388130

#### China - Xian

Tel: 86-29-8833-7252  
Fax: 86-29-8833-7256

#### China - Zhuhai

Tel: 86-756-3210040  
Fax: 86-756-3210049

### ASIA/PACIFIC

#### India - Bangalore

Tel: 91-80-3090-4444  
Fax: 91-80-3090-4080

#### India - New Delhi

Tel: 91-11-4160-8631  
Fax: 91-11-4160-8632

#### India - Pune

Tel: 91-20-2566-1512  
Fax: 91-20-2566-1513

#### Japan - Yokohama

Tel: 81-45-471- 6166  
Fax: 81-45-471-6122

#### Korea - Daegu

Tel: 82-53-744-4301  
Fax: 82-53-744-4302

#### Korea - Seoul

Tel: 82-2-554-7200  
Fax: 82-2-558-5932 or  
82-2-558-5934

#### Malaysia - Kuala Lumpur

Tel: 60-3-6201-9857  
Fax: 60-3-6201-9859

#### Malaysia - Penang

Tel: 60-4-227-8870  
Fax: 60-4-227-4068

#### Philippines - Manila

Tel: 63-2-634-9065  
Fax: 63-2-634-9069

#### Singapore

Tel: 65-6334-8870  
Fax: 65-6334-8850

#### Taiwan - Hsin Chu

Tel: 886-3-6578-300  
Fax: 886-3-6578-370

#### Taiwan - Kaohsiung

Tel: 886-7-536-4818  
Fax: 886-7-536-4803

#### Taiwan - Taipei

Tel: 886-2-2500-6610  
Fax: 886-2-2508-0102

#### Thailand - Bangkok

Tel: 66-2-694-1351  
Fax: 66-2-694-1350

### EUROPE

#### Austria - Wels

Tel: 43-7242-2244-39  
Fax: 43-7242-2244-393

#### Denmark - Copenhagen

Tel: 45-4450-2828  
Fax: 45-4485-2829

#### France - Paris

Tel: 33-1-69-53-63-20  
Fax: 33-1-69-30-90-79

#### Germany - Munich

Tel: 49-89-627-144-0  
Fax: 49-89-627-144-44

#### Italy - Milan

Tel: 39-0331-742611  
Fax: 39-0331-466781

#### Netherlands - Drunen

Tel: 31-416-690399  
Fax: 31-416-690340

#### Spain - Madrid

Tel: 34-91-708-08-90  
Fax: 34-91-708-08-91

#### UK - Wokingham

Tel: 44-118-921-5869  
Fax: 44-118-921-5820

03/26/09



Компания «Океан Электроники» предлагает заключение долгосрочных отношений при поставках импортных электронных компонентов на взаимовыгодных условиях!

Наши преимущества:

- Поставка оригинальных импортных электронных компонентов напрямую с производств Америки, Европы и Азии, а так же с крупнейших складов мира;
- Широкая линейка поставок активных и пассивных импортных электронных компонентов (более 30 млн. наименований);
- Поставка сложных, дефицитных, либо снятых с производства позиций;
- Оперативные сроки поставки под заказ (от 5 рабочих дней);
- Экспресс доставка в любую точку России;
- Помощь Конструкторского Отдела и консультации квалифицированных инженеров;
- Техническая поддержка проекта, помощь в подборе аналогов, поставка прототипов;
- Поставка электронных компонентов под контролем ВП;
- Система менеджмента качества сертифицирована по Международному стандарту ISO 9001;
- При необходимости вся продукция военного и аэрокосмического назначения проходит испытания и сертификацию в лаборатории (по согласованию с заказчиком);
- Поставка специализированных компонентов военного и аэрокосмического уровня качества (Xilinx, Altera, Analog Devices, Intersil, Interpoint, Microsemi, Actel, Aeroflex, Peregrine, VPT, Syfer, Eurofarad, Texas Instruments, MS Kennedy, Miteq, Cobham, E2V, MA-COM, Hittite, Mini-Circuits, General Dynamics и др.);

Компания «Океан Электроники» является официальным дистрибьютором и эксклюзивным представителем в России одного из крупнейших производителей разъемов военного и аэрокосмического назначения «JONHON», а так же официальным дистрибьютором и эксклюзивным представителем в России производителя высокотехнологичных и надежных решений для передачи СВЧ сигналов «FORSTAR».



## JONHON

«JONHON» (основан в 1970 г.)

Разъемы специального, военного и аэрокосмического назначения:

(Применяются в военной, авиационной, аэрокосмической, морской, железнодорожной, горно- и нефтедобывающей отраслях промышленности)

«FORSTAR» (основан в 1998 г.)

ВЧ соединители, коаксиальные кабели, кабельные сборки и микроволновые компоненты:

(Применяются в телекоммуникациях гражданского и специального назначения, в средствах связи, РЛС, а так же военной, авиационной и аэрокосмической отраслях промышленности).



Телефон: 8 (812) 309-75-97 (многоканальный)

Факс: 8 (812) 320-03-32

Электронная почта: [ocean@oceanchips.ru](mailto:ocean@oceanchips.ru)

Web: <http://oceanchips.ru/>

Адрес: 198099, г. Санкт-Петербург, ул. Калинина, д. 2, корп. 4, лит. А