



## Product Specification for Reference Only

Issued Date: 22 October, 2013 \_\_\_\_\_

Rev. : \_\_\_\_\_

Part Description: Fresnel Lens \_\_\_\_\_

MURATA Part No.: IML-0685 \_\_\_\_\_

The product specification in this sheet is for reference only.  
The contents of this specification is subject to change.

You are requested to receive the latest specification and to return one copy of the specification to us with your receipt signature before going into mass production.

Product engineering section  
Sensor module department  
Circuit module products division  
Murata MFG. Co.,Ltd.

MURATA MANUFACTURING CO.,LTD.

**1. Scope**

This product specification is applied to fresnel lens IML-0685 used for Pyroelectric infrared sensor IRA-S210ST01 to detect infrared ray. Please contact us when using this product for any other applications than described in the above.

**2. Murata Part Number**

IML-0685

**3. Outline Drawing and Dimensions**

See Figure 1

**4. Material etc.**

## 4-1 Material

High density polyethylene

## 4-2 Refractive Index

1.51

## 4-3 Transmittance

See Figure 4

## 4-4 Color

IML-0685 : Natural White

IML-0685G : Gray

IML-0685W : White

**5. Lens**

## 5-1 Field of View

See Figure 2 and Figure 3

**6. Operating Temperature**

-25 ~ 60°C

**7. Storage Temperature**

-30 ~ 80°C

## 8. Reliability

After each one of the test, No transformation, No crack

### 8-1 High temperature

85°C for 500hours

### 8-2 Low temperature

-30°C for 500hours

### 8-3 Humidity

60°C, 95%RH for 500hours

### 8-4 Heat cycle

20 times of the following cycle

-25°C, 30min.⇒ Room temp. 30min.⇒ 55°C, 30min.⇒ Room temp.

## 9. Caution

### 9-1 Limitation of Applications

Please contact us before using our products for the applications listed below which require especially high reliability for the prevention of defects which might directly cause damage to the third party's life, body or property.

1. Aircraft equipment
2. Aerospace equipment
3. Undersea equipment
4. Power plant control equipment
5. Medical equipment
6. Transportation equipment (vehicles, trans, ships, etc.)
7. Traffic signal equipment
8. Disaster prevention / crime prevention equipment
9. Data-processing equipment
10. Application of similar complexity and/or reliability requirement to the applications listed in the above

### 9-2 Fail-safe

Be sure to provide an appropriate fail-safe function on your product to prevent a second damage that may be caused by the abnormal function or the failure of our product.

## 10. Caution in use

### 10-1 Notice in design

- 1) Please set the direction of the tab of fresnel lens to the tab of the sensor.
- 2) To bring pyro-Element into the focus of fresnel lens, Please push the sensor until the step inside the fresnel lens.
- 3) Please add any mechanism for preventing dislocation or for preventing coming off from the sensor because of transition fit between sensor and fresnel lens.
- 4) Please avoid using the fresnel lens in the following conditions because it may cause failure or malfunction ;
  - a) in such a fluid as water, alcohol etc. corrosive gas (SO<sub>2</sub>, Cl<sub>2</sub>, NO<sub>x</sub> etc.) or sea breeze.
  - b) in high humidity.
  - c) in a place exposed directly to sun light or headlight of automobile.
  - d) in a place exposed directly to blow from air-conditioner or heater.
  - e) in such a place where infrared ray is shaded.
  - f) in any other place similar to the above (a) through (e).

### 10-2 Notice in handling and storage

- 1) Optical filter of sensor should not be scratched or soiled.
- 2) Strong shock should be avoided.
- 3) High temperature, high humidity, fluid as water or alcohol etc., corrosive gas (SO<sub>2</sub>, Cl<sub>2</sub>, NO<sub>x</sub> etc.) and sea breeze should be avoided.
- 4) Use the products within 6 months after receiving.

## 11. Note

- 1) Please make sure that your product has been evaluated in view of your specifications with our product being mounted to your product.
- 2) You are requested not to use our product deviating from the agreed specifications.
- 3) We consider it not to appropriate to include any terms and conditions with regard to the business transaction in the product specifications, drawings or other technical documents. Therefore, if your technical documents as above include such terms and conditions such as warranty clause, product liability clause, or intellectual property infringement liability clause, they will be deemed to be invalid.

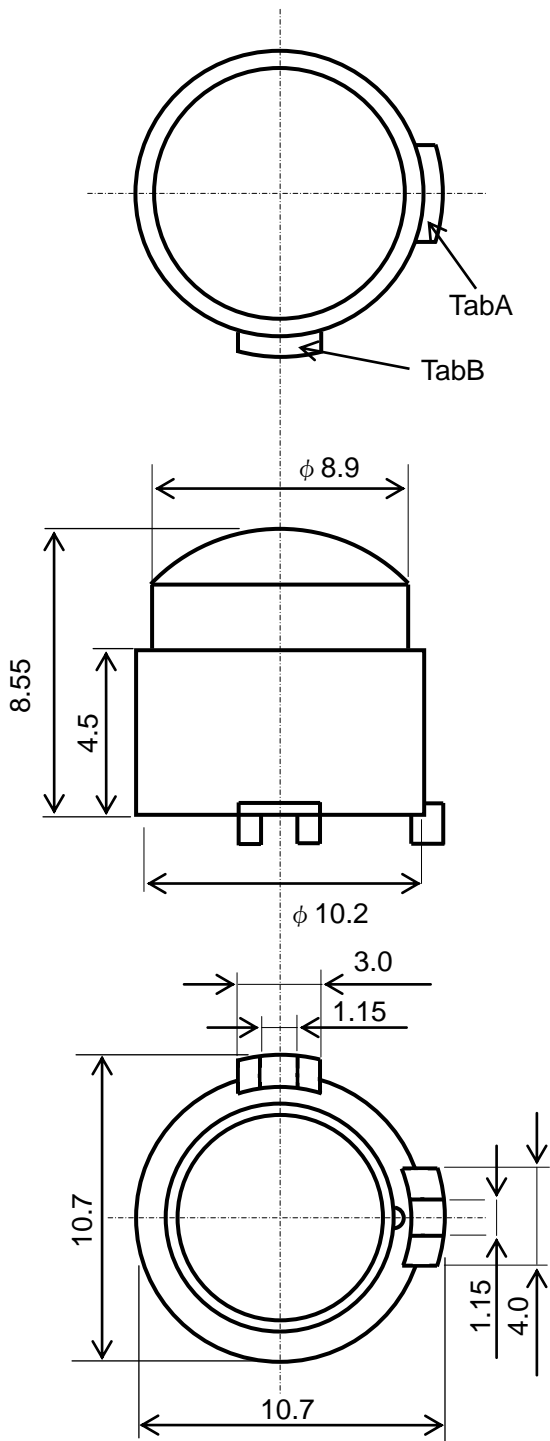

Unit : mm  
 General tolerance :  $\pm 0.2$

- ※Please set the direction of the tab on the fresnel lens to the tab on the sensor.
- ※To bring pyro-Element into the focus of fresnel lens, Please push the sensor until the step inside the fresnel lens.
- ※Please design the housing that the sensor does not receive infrared ray through the area shown as diagram in Figure A.
- ※Please design housing and set of sensor and lens to prevent from dislocation and coming off .

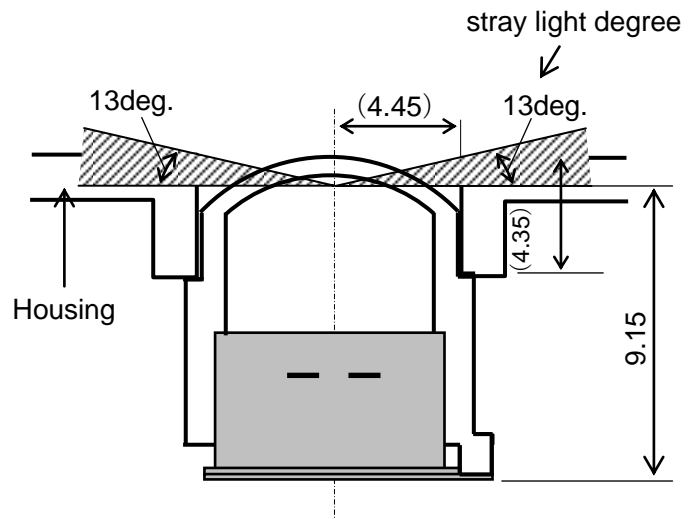
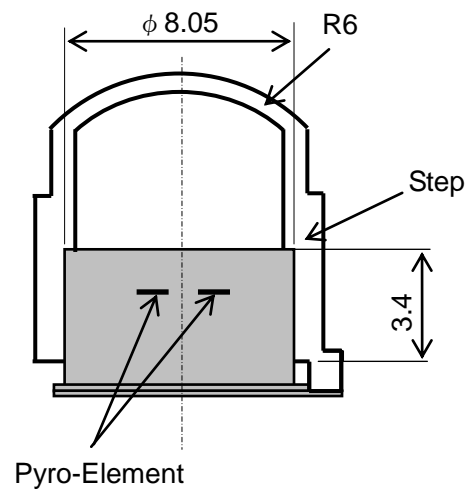
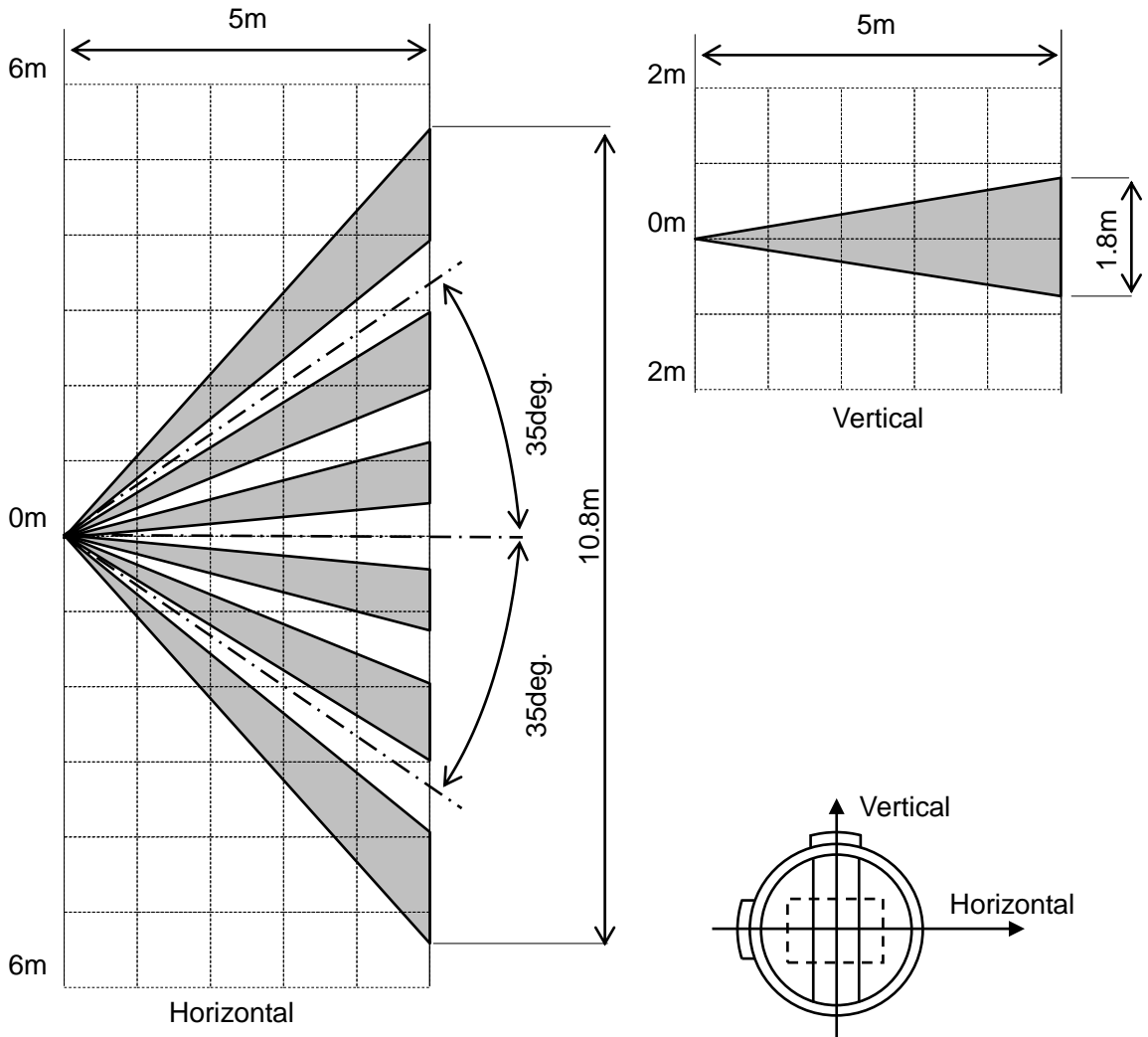

Figure A

An example of a design of the housing

Figure 1



※Assembled with Murata sensor IRA-S210 series

Figure 2

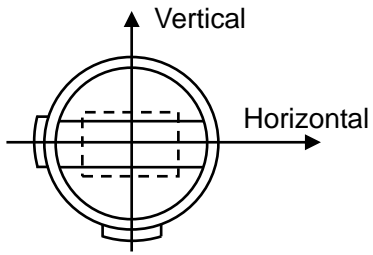
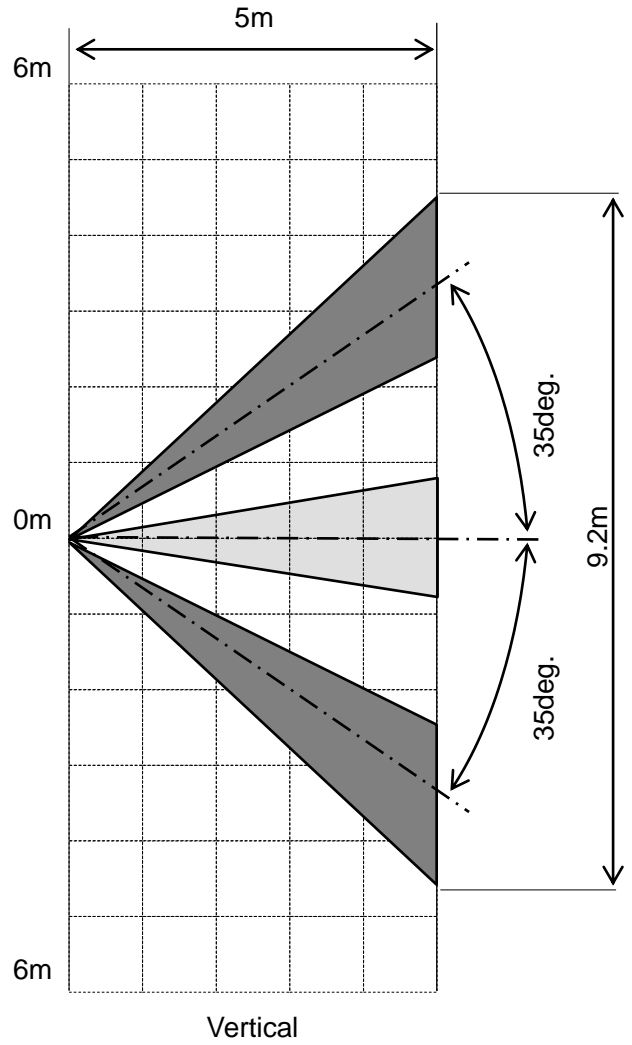
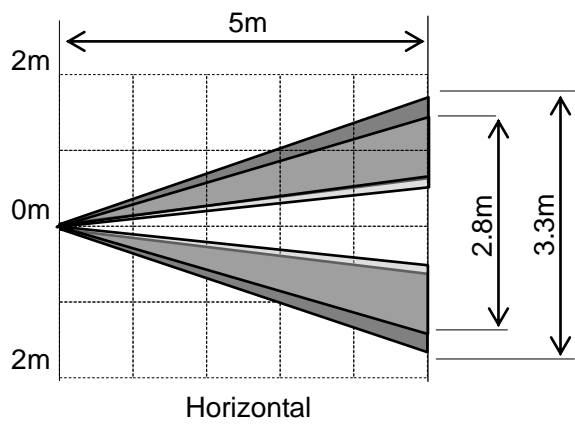

※Assembled with Murata sensor IRA-S210 series

**Figure 3**

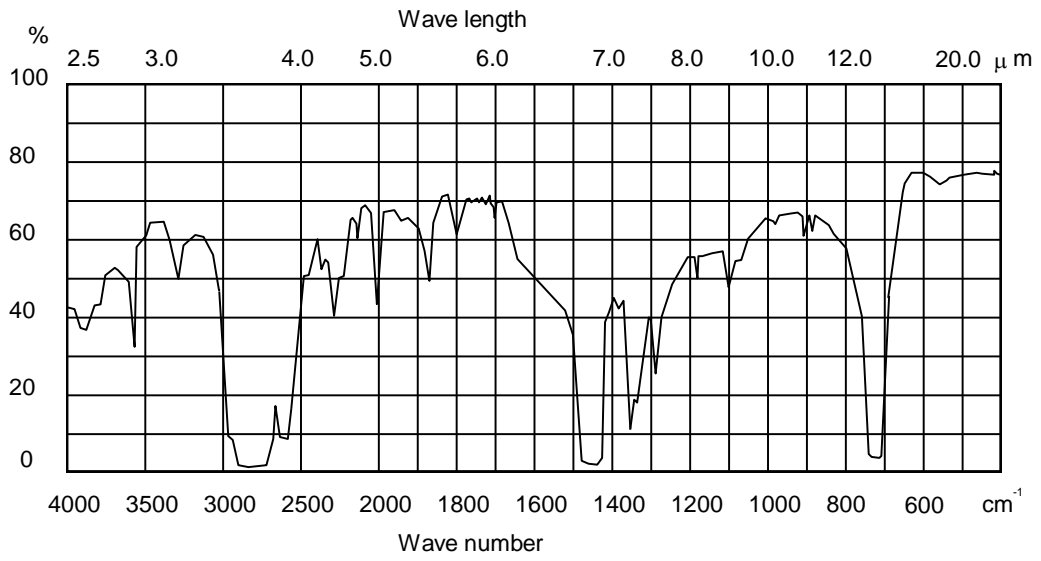

**Figure 4. Transmittance**



Компания «Океан Электроники» предлагает заключение долгосрочных отношений при поставках импортных электронных компонентов на взаимовыгодных условиях!

Наши преимущества:

- Поставка оригинальных импортных электронных компонентов напрямую с производств Америки, Европы и Азии, а так же с крупнейших складов мира;
- Широкая линейка поставок активных и пассивных импортных электронных компонентов (более 30 млн. наименований);
- Поставка сложных, дефицитных, либо снятых с производства позиций;
- Оперативные сроки поставки под заказ (от 5 рабочих дней);
- Экспресс доставка в любую точку России;
- Помощь Конструкторского Отдела и консультации квалифицированных инженеров;
- Техническая поддержка проекта, помощь в подборе аналогов, поставка прототипов;
- Поставка электронных компонентов под контролем ВП;
- Система менеджмента качества сертифицирована по Международному стандарту ISO 9001;
- При необходимости вся продукция военного и аэрокосмического назначения проходит испытания и сертификацию в лаборатории (по согласованию с заказчиком);
- Поставка специализированных компонентов военного и аэрокосмического уровня качества (Xilinx, Altera, Analog Devices, Intersil, Interpoint, Microsemi, Actel, Aeroflex, Peregrine, VPT, Syfer, Eurofarad, Texas Instruments, MS Kennedy, Miteq, Cobham, E2V, MA-COM, Hittite, Mini-Circuits, General Dynamics и др.);

Компания «Океан Электроники» является официальным дистрибьютором и эксклюзивным представителем в России одного из крупнейших производителей разъемов военного и аэрокосмического назначения «JONHON», а так же официальным дистрибьютором и эксклюзивным представителем в России производителя высокотехнологичных и надежных решений для передачи СВЧ сигналов «FORSTAR».



## JONHON

«JONHON» (основан в 1970 г.)

Разъемы специального, военного и аэрокосмического назначения:

(Применяются в военной, авиационной, аэрокосмической, морской, железнодорожной, горно- и нефтедобывающей отраслях промышленности)

«FORSTAR» (основан в 1998 г.)

ВЧ соединители, коаксиальные кабели, кабельные сборки и микроволновые компоненты:

(Применяются в телекоммуникациях гражданского и специального назначения, в средствах связи, РЛС, а так же военной, авиационной и аэрокосмической отраслях промышленности).



Телефон: 8 (812) 309-75-97 (многоканальный)

Факс: 8 (812) 320-03-32

Электронная почта: [ocean@oceanchips.ru](mailto:ocean@oceanchips.ru)

Web: <http://oceanchips.ru/>

Адрес: 198099, г. Санкт-Петербург, ул. Калинина, д. 2, корп. 4, лит. А