

NOTES: SEE SHEET 2.

1" = 1.50 [38.1]
2" = 2.50 [63.5]

1" = 1.270 [32.26]
2" = 2.270 [57.66]

1" = 1.235 [31.4]
2" = 2.235 [56.8]

REVISIONS			
LTR	DESCRIPTION	DATE	APPROVED
U1	REVISED PER ECO-11-005139	20APR11	HMR
V	REVISED PER ECO-12-020967	07DEC12	CT

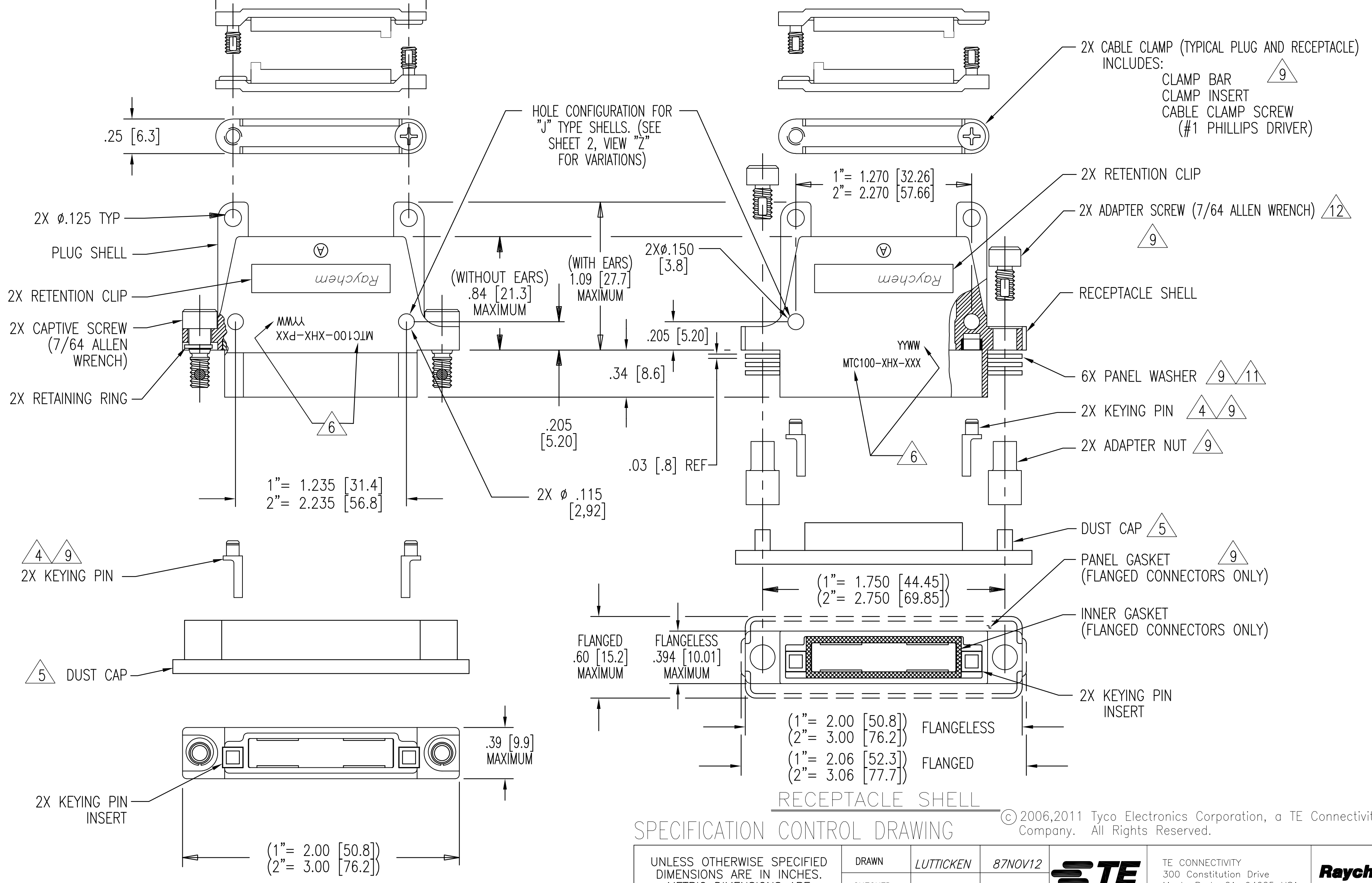

2X CABLE CLAMP (TYPICAL PLUG AND RECEPTACLE)
INCLUDES:
CLAMP BAR (9)
CLAMP INSERT
CABLE CLAMP SCREW
(#1 PHILLIPS DRIVER)

2X RETENTION CLIP (9)
2X ADAPTER SCREW (7/64 ALLEN WRENCH) (12)

RECEPTACLE SHELL
6X PANEL WASHER (9, 11)
2X KEYING PIN (4, 9)
2X ADAPTER NUT (9)

DUST CAP (5)
PANEL GASKET (FLANGED CONNECTORS ONLY) (9)
INNER GASKET (FLANGED CONNECTORS ONLY)

2X KEYING PIN INSERT

	FLANGED	FLANGELESS	
	.60 [15.2] MAXIMUM	.394 [10.01] MAXIMUM	
	(1" = 1.750 [44.45]) (2" = 2.750 [69.85])		
	(1" = 2.00 [50.8]) (2" = 3.00 [76.2])	FLANGELESS	
	(1" = 2.06 [52.3]) (2" = 3.06 [77.7])	FLANGED	

RECEPTACLE SHELL

SPECIFICATION CONTROL DRAWING

© 2006,2011 Tyco Electronics Corporation, a TE Connectivity Ltd. Company. All Rights Reserved.

UNLESS OTHERWISE SPECIFIED DIMENSIONS ARE IN INCHES. METRIC DIMENSIONS ARE IN BRACKETS.	DRAWN	LUTTICKEN	87NOV12	 TE CONNECTIVITY 300 Constitution Drive Menlo Park, CA. 94025 USA
	CHECKED	J.B.		
	APPROVED	J.BLAIR	87DEC29	
	APPROVED	J.CAMERON	88JAN05	
DECIMALS .XXX ±.005 { .13 mm } .XX ±.02 { .5 mm }	CAD NAME	MTC100-XHX-XXX-XXXα		TITLE
ANGLES .X ±	THIRD ANGLE PROJECTION			SHELL, PLUG AND RECEPTACLE MTC100 SERIES
WEIGHT:				SIZE C
				CODE IDENT. NO. 06090
				DWG. NO. MTC100-XHX-XXX-XXX
				REV V
				DO NOT SCALE THIS DRAWING
				SHEET 1 OF 3

IF THIS DOCUMENT IS PRINTED IT BECOMES UNCONTROLLED.
CHECK FOR THE LATEST REVISION.

PLUG SHELL

SHEET 1
DWG. NO. MTC100-XHX-XXX-XXX

NOTES:

1. PART NUMBER VARIABLES: (NOT ALL POSSIBLE CONFIGURATIONS SHOWN ON THIS DRAWING ARE AVAILABLE AS STANDARD PRODUCTS. PLEASE CHECK WITH RAYCHEM TO CONFIRM AVAILABILITY.)

MTC100-XHX-XXX-XXX

MODIFICATIONS (see table I) (THIS SPACE BLANK IF NO MODIFICATION IS APPLICABLE)

- 1= W/O CABLE CLAMP AND W/O EARS ON SHELL
- 2= WITH CABLE CLAMP AND EARS ON SHELL
- 3= W/O CABLE CLAMP AND WITH EARS

- 1= BLACK ANODIZED (WHITE MARKING)
- 2= ELECTROLESS NICKEL (BLACK MARKING)
- 3= CADMIUM OVER NICKEL UNDERPLATE (BLACK MARKING)

- P= PLUG
- R= FLANGELESS RECEPTACLE
- F= FLANGED RECEPTACLE: STANDARD ("J" TYPE) HAS NON CONDUCTIVE FLUOROSILICONE GASKET SHIELDED ("S" TYPE) HAS CONDUCTIVE FLUOROSILICONE GASKET

- 1= 1 INCH
- 2= 2 INCH

- J= STANDARD TYPE
- S= SHIELDED
- Y= SPECIAL TYPE: REFER TO INDIVIDUAL SPECIFICATION CONTROL DRAWINGS FOR DESCRIPTIONS

2. MATERIAL:

- A) SHELL ALUMINUM ALLOY PER ASTM B85
- B) RETENTION CLIP COPPER ALLOY 172 PER ASTM B194
- C) ADAPTER SCREW OR CAP SCREW STAINLESS STEEL PER SAE-AMS-QQ-S-763, 300 SERIES
- D) ADAPTER NUT OR RETAINER BUSHING STAINLESS STEEL PER SAE-AMS-QQ-S-763, 300 SERIES
- E) PANEL OR LOCK WASHER STAINLESS STEEL PER SAE-AMS-QQ-S-763 OR ASTM B240, 300 SERIES
- F) KEYING PIN HIGH GRADE POLYARYLENE THERMOPLASTIC, MOLDED
- G) KEY PINS INSERT HIGH GRADE POLYARYLENE THERMOPLASTIC, MOLDED
- H) CLAMP BAR STAINLESS STEEL PER SAE-AMS-QQ-S-763, 300 SERIES
- J) CLAMP INSERT SILICONE ELASTOMER PER MIL-R-25988
- K) CAPTIVE SCREW STAINLESS STEEL PER SAE-AMS-QQ-S-763, 300 SERIES
- L) RETAINING RING COPPER ALLOY 172 PER ASTM B194

3. FINISH:

	APPLIES TO NICKEL PLATED CONNECTORS	APPLIES TO CADMIUM PLATED CONNECTORS	APPLIES TO BLACK ANODIZED CONNECTORS
A) SHELL	NICKEL PLATED PER SAE-AMS-C-26074 CLASS 3, GRADE B	CADMIUM PLATED PER SAE-AMS-QQ-P-416 OVER NICKEL UNDERPLATE	BLACK ANODIZED PER MIL-A-8625, TYPE II, CLASS 2
B) RETENTION CLIP	NICKEL PLATED PER SAE-AMS-C-26074 CLASS 2, .00002 MINIMUM	CADMIUM PLATED PER SAE-AMS-QQ-P-416	NICKEL PLATED PER SAE-AMS-C-26074 CLASS 2, .00002 MINIMUM
C) ADAPTER OR CAP SCREW	PASSIVATED PER SAE-AMS-2700	CADMIUM PLATED PER SAE-AMS-QQ-P-416	PASSIVATED PER SAE-AMS-2700
D) ADAPTER NUT OR RETAINER BUSHING	PASSIVATED PER SAE-AMS-2700	CADMIUM PLATED PER SAE-AMS-QQ-P-416	PASSIVATED PER SAE-AMS-2700
E) PANEL OR LOCK WASHER	PASSIVATED PER SAE-AMS-2700	CADMIUM PLATED PER SAE-AMS-QQ-P-416	PASSIVATED PER SAE-AMS-2700
F) CLAMP BAR	PASSIVATED PER SAE-AMS-2700	CADMIUM PLATED PER SAE-AMS-QQ-P-416	PASSIVATED PER SAE-AMS-2700
G) CAPTIVE SCREW	PASSIVATED PER SAE-AMS-2700	CADMIUM PLATED PER SAE-AMS-QQ-P-416	PASSIVATED PER SAE-AMS-2700
H) RETAINING RING	NICKEL PLATED PER SAE-AMS-C-26074	CADMIUM PLATED PER SAE-AMS-QQ-P-416	NICKEL PLATED PER SAE-AMS-C-26074

4. FOR MOUNTING / MATING AND KEYING INFORMATION, SEE RAYCHEM DRAWING D652-0012.

5. DUST CAP SUPPLIED WITH EACH PLUG OR RECEPTACLE. NO DUST CAPS ARE SUPPLIED WHEN SHELLS ARE SHIPPED TO CUSTOMER SPECIFICATION NUMBER 991006.

6. APPROPRIATE PART NUMBER AND DATE CODE ARE STAMPED APPROXIMATELY AS SHOWN.

7. THESE PARTS MEET THE REQUIREMENTS OF RAYCHEM SPECIFICATION C-6111.

8. FLANGED RECEPTACLE CONNECTORS PROPERLY MATED AND TORQUED TO 9 INCH POUNDS WILL EXHIBIT AN AIR LEAK RATE NOT EXCEEDING .5 CC / SECOND AT 30 PSI AND 25° C. (APPLICABLE ONLY TO FLANGED RECEPTACLES WITH PIN INSERTS)

9. THESE ITEMS ARE SUPPLIED UNASSEMBLED.

10. SEE TABLE II & TABLE 4 SHEET 3, WEIGHTS ARE WITHOUT DUST CAP.

11. THIS RECEPTACLE IS REAR PANEL MOUNTED BY REMOVING AS MANY PANEL WASHERS AS REQUIRED TO ACCOMMODATE THE THICKNESS OF THE PANEL BEING USED. (SEE TABLE III)

12. RECEPTACLE ADAPTER SCREWS (CAP SCREWS) ARE TO BE TORQUED TO 15±1 INCH-LBS (1.0±0.07 N-M)

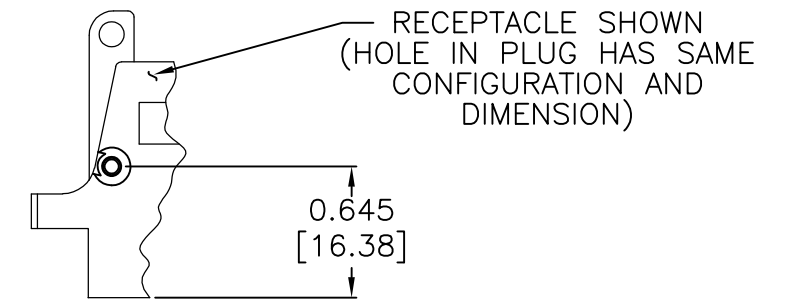

HOLE CONFIGURATION FOR ALL "S" TYPE SHELLS AND FLANGED "J" TYPE RECEPTACLE SHELLS

VIEW "Z"

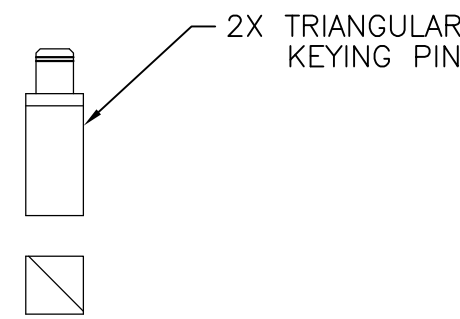

APPLIES TO -014 MODIFICATION (see table I)

VIEW "W"

PANEL THICKNESS	NUMBER OF PANEL WASHERS FOR EACH FASTENER
0.031/0.036 [0.8]/[0.9]	2
0.062/0.067 [1.5]/[1.7]	1
0.093/0.097 [2.3]/[2.4]	0

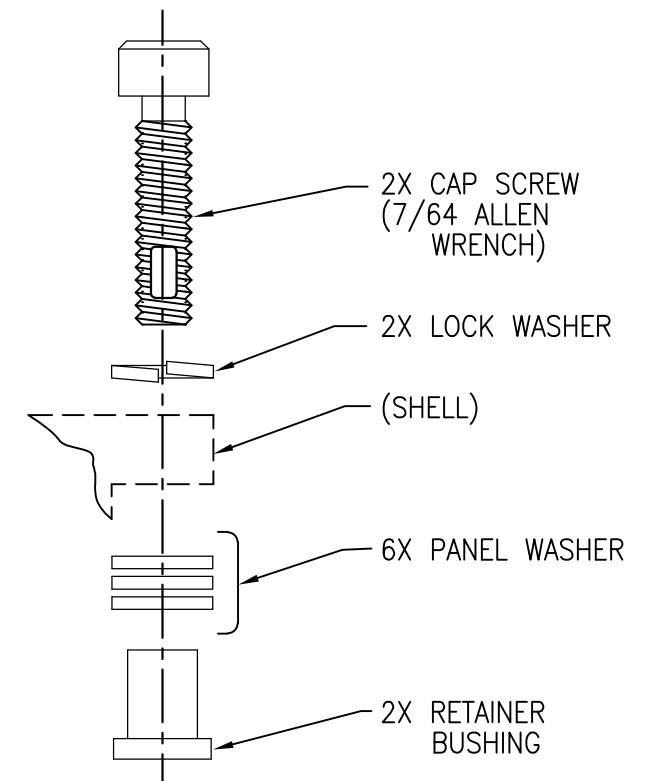

MTC50 HARDWARE APPLIES TO -020 MODIFICATION (see table I)

VIEW "Y"

MODIFICATION DASH NUMBER	DESCRIPTION
-001	SAME AS STANDARD ASSEMBLY WITH EARS EXCEPT WITHOUT CABLE CLAMPS
-007	SAME AS STANDARD ASSEMBLY EXCEPT METAL PARTS ARE PLATED CADMIUM OVER NICKEL, SUPPLIED WITH MTC50 MOUNTING/ MATING HARDWARE (SEE VIEW "Y")
-014	SAME AS STANDARD EXCEPT ADDITIONALLY TRIANGULAR KEYING PINS INCLUDED (SEE VIEW "W")
-020	SAME AS STANDARD EXCEPT SUPPLIED WITH MTC50 MOUNTING/MATING HARDWARE (SEE VIEW "Y")
-028	SAME AS STANDARD ASSEMBLY EXCEPT SUPPLIED WITHOUT HARDWARE

IF THIS DOCUMENT IS PRINTED IT BECOMES UNCONTROLLED. CHECK FOR THE LATEST REVISION.

DWG. NO.	REV
MTC100-XHX-XXX-XXX	✓
CAD FILE NO: C061320b.dwg	SHEET 2 OF 3

THE FOLLOWING TABLE CONSISTS OF WEIGHTS FOR THESE SPECIFIC PART NUMBERS.

TABLE II 	
PART NUMBER	WEIGHT MAXIMUM GRAMS
MTC100-JH1-F32	30.8
MTC100-JH1-P32	23.8
MTC100-JH1-R32	27.3
MTC100-JH2-F32	43.7
MTC100-JH2-P32	34.2
MTC100-JH2-R32	38.3
MTC100-SH1-F33	24.2 *
MTC100-SH1-P33	16.1 *
MTC100-SH1-R33	20.3 *
MTC100-SH2-F33	32.3 *
MTC100-SH2-P33	22.7 *
MTC100-SH2-R33	27.0 *

TABLE 4 	
PART NUMBER	WEIGHT MAXIMUM GRAMS
MTC100-JH1-F22	30.8
MTC100-JH1-P22	23.8
MTC100-JH1-R22	27.3
MTC100-JH2-F22	43.7
MTC100-JH2-P22	34.2
MTC100-JH2-R22	38.3
MTC100-SH1-F23	24.2 *
MTC100-SH1-P23	16.1 *
MTC100-SH1-R23	20.3 *
MTC100-SH2-F23	32.3 *
MTC100-SH2-P23	22.7 *
MTC100-SH2-R23	27.0 *

* = WEIGHT DOES NOT INCLUDE CABLE CLAMP

IF THIS DOCUMENT IS PRINTED IT BECOMES UNCONTROLLED.
CHECK FOR THE LATEST REVISION.

DWG. NO. MTC100-XHX-XXX-XXX	REV V
CAD FILE: C061320c.DWG	SHEET 3 OF 3

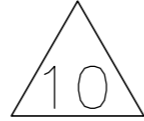
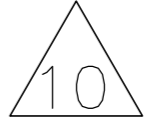
DWG. NO. MTC100-XHX-XXX-XXX SHEET 3

Компания «Океан Электроники» предлагает заключение долгосрочных отношений при поставках импортных электронных компонентов на взаимовыгодных условиях!

Наши преимущества:

- Поставка оригинальных импортных электронных компонентов напрямую с производств Америки, Европы и Азии, а так же с крупнейших складов мира;
- Широкая линейка поставок активных и пассивных импортных электронных компонентов (более 30 млн. наименований);
- Поставка сложных, дефицитных, либо снятых с производства позиций;
- Оперативные сроки поставки под заказ (от 5 рабочих дней);
- Экспресс доставка в любую точку России;
- Помощь Конструкторского Отдела и консультации квалифицированных инженеров;
- Техническая поддержка проекта, помощь в подборе аналогов, поставка прототипов;
- Поставка электронных компонентов под контролем ВП;
- Система менеджмента качества сертифицирована по Международному стандарту ISO 9001;
- При необходимости вся продукция военного и аэрокосмического назначения проходит испытания и сертификацию в лаборатории (по согласованию с заказчиком);
- Поставка специализированных компонентов военного и аэрокосмического уровня качества (Xilinx, Altera, Analog Devices, Intersil, Interpoint, Microsemi, Actel, Aeroflex, Peregrine, VPT, Syfer, Eurofarad, Texas Instruments, MS Kennedy, Miteq, Cobham, E2V, MA-COM, Hittite, Mini-Circuits, General Dynamics и др.);

Компания «Океан Электроники» является официальным дистрибьютором и эксклюзивным представителем в России одного из крупнейших производителей разъемов военного и аэрокосмического назначения «JONHON», а так же официальным дистрибьютором и эксклюзивным представителем в России производителя высокотехнологичных и надежных решений для передачи СВЧ сигналов «FORSTAR».



JONHON

«JONHON» (основан в 1970 г.)

Разъемы специального, военного и аэрокосмического назначения:

(Применяются в военной, авиационной, аэрокосмической, морской, железнодорожной, горно- и нефтедобывающей отраслях промышленности)

«FORSTAR» (основан в 1998 г.)

ВЧ соединители, коаксиальные кабели, кабельные сборки и микроволновые компоненты:

(Применяются в телекоммуникациях гражданского и специального назначения, в средствах связи, РЛС, а так же военной, авиационной и аэрокосмической отраслях промышленности).



Телефон: 8 (812) 309-75-97 (многоканальный)

Факс: 8 (812) 320-03-32

Электронная почта: ocean@oceanchips.ru

Web: <http://oceanchips.ru/>

Адрес: 198099, г. Санкт-Петербург, ул. Калинина, д. 2, корп. 4, лит. А