

### Features

- Any frequency between 1 MHz and 220 MHz accurate to 6 decimal places
- Widest pull range options:  $\pm 25$ ,  $\pm 50$ ,  $\pm 80$ ,  $\pm 100$ ,  $\pm 150$ ,  $\pm 200$ ,  $\pm 400$ ,  $\pm 800$ ,  $\pm 1600$ ,  $\pm 3200$  ppm
- 0.23 ps RMS phase jitter (typ) over 12 kHz to 20 MHz bandwidth
- Wide temperature range support from  $-40^{\circ}\text{C}$  to  $105^{\circ}\text{C}$
- Industry-standard packages: 7.0 x 5.0 mm, 5.0 x 3.2 mm, 3.2 x 2.5 mm packages
- For frequencies 220.000001 MHz to 720 MHz, refer to [SiT3373](#)

### Applications

- Cable Modem Termination System (CMTS), Video, Broadcasting System, Audio, Industrial Sensors, Remote Radio Head (RRH)
- SATA, SAS, 10Gbps Ethernet, Fibre Channel, PCI-Express



### Electrical Characteristics

**Table 1. Electrical Characteristics – Common to LVPECL, LVDS and HCSL**

All Min and Max limits in the Electrical Characteristics tables are specified over temperature and rated operating voltage with standard output termination show in the termination diagrams. Typical values are at  $25^{\circ}\text{C}$  and nominal supply voltage.

Parameter	Symbol	Min.	Typ.	Max.	Unit	Condition
<b>Frequency Range</b>						
Output Frequency Range	f	1	–	220	MHz	Accurate to 6 decimal places
<b>Frequency Stability</b>						
Frequency Stability	F_stab	-15	–	+15	ppm	Inclusive of initial tolerance, operating temperature, rated power supply voltage, load variations, and first year aging at $25^{\circ}\text{C}$ . Contact <a href="#">SiTime</a> for $\pm 15$ ppm.
		-25	–	+25	ppm	
		-35	–	+35	ppm	
		-50	–	+50	ppm	
<b>Temperature Range</b>						
Operating Temperature Range	T_use	-20	–	+70	$^{\circ}\text{C}$	Extended Commercial
		-40	–	+85	$^{\circ}\text{C}$	Industrial.
		-40	–	+95	$^{\circ}\text{C}$	
		-40	–	+105	$^{\circ}\text{C}$	Extended Industrial
<b>Supply Voltage</b>						
Supply Voltage	Vdd	2.97	3.3	3.63	V	
		2.7	3.0	3.3	V	
		2.52	2.8	3.08	V	
		2.25	2.5	2.75	V	
<b>Voltage Control Characteristics</b>						
Pull Range	PR	$\pm 25$ , $\pm 50$ , $\pm 80$ , $\pm 100$ , $\pm 150$ , $\pm 200$ , $\pm 400$ , $\pm 800$ , $\pm 1600$ , $\pm 3200$			ppm	See the APR (Absolute Pull Range) <a href="#">Table 11</a> . Contact <a href="#">SiTime</a> for custom pull range options.
Upper Control Voltage	VC_U	90%	–	–	Vdd	Voltage at which maximum frequency deviation is guaranteed
Lower Control Voltage	VC_L	–	–	10%	Vdd	Voltage at which minimum frequency deviation is guaranteed
Control Voltage Input Impedance	VC_z	–	10	–	M $\Omega$	
Control Voltage Input Bandwidth	V_c	–	10	–	kHz	Contact <a href="#">SiTime</a> for other input bandwidth options
Pull Range Linearity	Lin	–	–	1.0	%	
Frequency Change Polarity	–	Positive Slope		–		
<b>Input Characteristics</b>						
Input Voltage High	VIH	70%	–	–	Vdd	Pin 2, OE
Input Voltage Low	VIL	–	–	30%	Vdd	Pin 2, OE
Input Pull-up Impedance	Z_in	–	100	–	k $\Omega$	Pin 2, OE logic high or logic low
<b>Output Characteristics</b>						
Duty Cycle	DC	45	–	55	%	
<b>Startup and OE Timing</b>						
Startup Time	T_start	–	–	3.0	ms	Measured from the time Vdd reaches its rated minimum value.
OE Enable/Disable Time	T_oe	–	–	3.8	$\mu\text{s}$	f = 156.25 MHz. Measured from the time OE pin reaches rated VIH and VIL to the time clock pins reach 90% of swing and high-Z. See <a href="#">Figure 7</a> and <a href="#">Figure 8</a>

Table 2. Electrical Characteristics – LVPECL Specific

Parameter	Symbol	Min.	Typ.	Max.	Unit	Condition
<b>Current Consumption</b>						
Current Consumption	I <sub>dd</sub>	–	–	92	mA	Excluding Load Termination Current, V <sub>dd</sub> = 3.3V or 2.5V
OE Disable Supply Current	I <sub>OE</sub>	–	–	61	mA	OE = Low
Output Disable Leakage Current	I <sub>leak</sub>	–	0.15	–	μA	OE = Low
Maximum Output Current	I <sub>driver</sub>	–	–	33	mA	Maximum average current drawn from OUT+ or OUT-
<b>Output Characteristics</b>						
Output High Voltage	VOH	V <sub>dd</sub> -1.15	–	V <sub>dd</sub> -0.7	V	See Figure 3
Output Low Voltage	VOL	V <sub>dd</sub> -2.0	–	V <sub>dd</sub> -1.5	V	See Figure 3
Output Differential Voltage Swing	V <sub>Swing</sub>	1.2	1.6	2.0	V	See Figure 4
Rise/Fall Time	T <sub>r</sub> , T <sub>f</sub>	–	225	290	ps	20% to 80%, see Figure 4
<b>Jitter – 7.0 x 5.0 mm package</b>						
RMS Period Jitter <sup>[1]</sup>	T <sub>jitt</sub>	–	1.0	1.6	ps	f = 100, 156.25 or 212.5 MHz, V <sub>dd</sub> = 3.3V or 2.5V
RMS Phase Jitter (random)	T <sub>phj</sub>	–	0.225	0.270	ps	f = 156.25 MHz, Integration bandwidth = 12 kHz to 20 MHz, all V <sub>dd</sub> levels, includes spurs, pull range = 100 ppm. Temperature ranges -20 to 70°C and -40 to 85°C.
		–	0.225	0.300	ps	f = 156.25 MHz, Integration bandwidth = 12 kHz to 20 MHz, all V <sub>dd</sub> levels, includes spurs, pull range = 100 ppm. Temperature ranges -40 to 95 °C and -40 to 105°C
		–	0.1	–	ps	f = 156.25 or 322.265625 MHz, IEEE802.3-2005 10GbE jitter mask integration bandwidth = 1.875 MHz to 20 MHz, includes spurs, all V <sub>dd</sub> levels.
<b>Jitter – 5.0 x 3.2 mm and 3.2 x 2.5 mm package</b>						
RMS Period Jitter <sup>[1]</sup>	T <sub>jitt</sub>	–	1.0	1.6	ps	f = 100, 156.25 or 212.5 MHz, V <sub>dd</sub> = 3.3V or 2.5V
RMS Phase Jitter (random)	T <sub>phj</sub>	–	0.225	0.275	ps	f = 156.25 MHz, Integration bandwidth = 12 kHz to 20 MHz, all V <sub>dd</sub> levels, includes spurs, pull range = 100 ppm. Temperature ranges -20 to 70°C and -40 to 85°C.
		–	0.225	0.340	ps	f = 156.25 MHz, Integration bandwidth = 12 kHz to 20 MHz, all V <sub>dd</sub> levels, includes spurs, pull range = 100 ppm. Temperature ranges -40 to 95 °C and -40 to 105°C
		–	0.1	–	ps	f = 156.25 or 322.265625 MHz, IEEE802.3-2005 10GbE jitter mask integration bandwidth = 1.875 MHz to 20 MHz, includes spurs, all V <sub>dd</sub> levels.

**Notes:**

1. Measured according to JESD65B

Table 3. Electrical Characteristics – LVDS

Parameter	Symbol	Min.	Typ.	Max.	Unit	Condition
<b>Current Consumption</b>						
<b>Current Consumption</b>	I <sub>dd</sub>	–	–	84	mA	Excluding Load Termination Current, V <sub>dd</sub> = 3.3V or 2.5V
<b>OE Disable Supply Current</b>	I <sub>OE</sub>	–	–	62	mA	OE = Low
<b>Output Disable Leakage Current</b>	I <sub>leak</sub>	–	0.15	–	μA	OE = Low
<b>Output Characteristics</b>						
<b>Differential Output Voltage</b>	V <sub>OD</sub>	250	–	450	mV	See <a href="#">Figure 5</a>
<b>VOD Magnitude Change</b>	ΔV <sub>OD</sub>	–	–	50	mV	See <a href="#">Figure 5</a>
<b>Offset Voltage</b>	V <sub>OS</sub>	1.125	–	1.375	V	See <a href="#">Figure 5</a>
<b>VOS Magnitude Change</b>	ΔV <sub>OS</sub>	–	–	50	mV	See <a href="#">Figure 5</a>
<b>Rise/Fall Time</b>	T <sub>r</sub> , T <sub>f</sub>	–	400	470	ps	Measured with 2 pF capacitive loading to GND, 20% to 80%, see <a href="#">Figure 6</a>
<b>Jitter – 7.0 x 5.0 mm package</b>						
<b>RMS Period Jitter<sup>[2]</sup></b>	T <sub>jitt</sub>	–	1.0	1.6	ps	f = 100, 156.25 or 212.5 MHz, V <sub>dd</sub> = 3.3V or 2.5V
<b>RMS Phase Jitter (random)</b>	T <sub>phj</sub>	–	0.215	0.265	ps	f = 156.25 MHz, Integration bandwidth = 12 kHz to 20 MHz, all V <sub>dd</sub> levels, includes spurs, pull range = 100 ppm. Temperature ranges -20 to 70°C and -40 to 85°C.
		–	0.215	0.300	ps	f = 156.25 MHz, Integration bandwidth = 12 kHz to 20 MHz, all V <sub>dd</sub> levels, includes spurs, pull range = 100 ppm. Temperature ranges -40 to 95 °C and -40 to 105°C
		–	0.1	–	ps	f = 156.25 or 322.265625 MHz, IEEE802.3-2005 10GbE jitter mask integration bandwidth = 1.875 MHz to 20 MHz, includes spurs, all V <sub>dd</sub> levels.
<b>Jitter – 5.0 x 3.2 mm and 3.2 x 2.5 mm package</b>						
<b>RMS Period Jitter<sup>[2]</sup></b>	T <sub>jitt</sub>	–	1.0	1.6	ps	f = 100, 156.25 or 212.5 MHz, V <sub>dd</sub> = 3.3V or 2.5V
<b>RMS Phase Jitter (random)</b>	T <sub>phj</sub>	–	0.235	0.275	ps	f = 156.25 MHz, Integration bandwidth = 12 kHz to 20 MHz, all V <sub>dd</sub> levels, includes spurs, pull range = 100 ppm. Temperature ranges -20 to 70°C and -40 to 85°C.
		–	0.235	0.320	ps	f = 156.25 MHz, Integration bandwidth = 12 kHz to 20 MHz, all V <sub>dd</sub> levels, includes spurs, pull range = 100 ppm. Temperature ranges -40 to 95 °C and -40 to 105°C
		–	0.1	–	ps	f = 156.25 or 322.265625 MHz, IEEE802.3-2005 10GbE jitter mask integration bandwidth = 1.875 MHz to 20 MHz, includes spurs, all V <sub>dd</sub> levels.

**Notes:**

2. Measured according to JESD65B

Table 4. Electrical Characteristics – HCSL

Parameter	Symbol	Min.	Typ.	Max.	Unit	Condition
<b>Current Consumption</b>						
Current Consumption	I <sub>dd</sub>	–	–	97	mA	Excluding Load Termination Current, V <sub>dd</sub> = 3.3V or 2.5V
OE Disable Supply Current	I <sub>OE</sub>	–	–	62	mA	OE = Low
Output Disable Leakage Current	I <sub>leak</sub>	–	0.15	–	μA	OE = Low
Maximum Output Current	I <sub>driver</sub>	–	–	35	mA	Maximum average current drawn from OUT+ or OUT-
<b>Output Characteristics</b>						
Output High Voltage	VOH	0.60	–	0.90	V	See Figure 3
Output Low Voltage	VOL	-0.05	–	0.08	V	See Figure 3
Output Differential Voltage Swing	V <sub>Swing</sub>	1.2	1.4	1.80	V	See Figure 4
Rise/Fall Time	T <sub>r</sub> , T <sub>f</sub>	–	360	495	ps	Measured with 2 pF capacitive loading to GND, 20% to 80%, See Figure 4
<b>Jitter – 7.0 x 5.0 mm package</b>						
RMS Period Jitter <sup>[3]</sup>	T <sub>jitt</sub>	–	1.0	1.6	ps	f = 100, 156.25 or 212.5 MHz, V <sub>dd</sub> = 3.3V or 2.5V
RMS Phase Jitter (random)	T <sub>phj</sub>	–	0.220	0.270	ps	f = 156.25 MHz, Integration bandwidth = 12 kHz to 20 MHz, all V <sub>dd</sub> levels, includes spurs, pull range = 100 ppm. Temperature ranges -20 to 70°C and -40 to 85°C.
		–	0.220	0.300	ps	f = 156.25 MHz, Integration bandwidth = 12 kHz to 20 MHz, all V <sub>dd</sub> levels, includes spurs, pull range = 100 ppm. Temperature ranges -40 to 95 °C and -40 to 105°C
		–	0.1	–	ps	f = 156.25 or 322.265625 MHz, IEEE802.3-2005 10GbE jitter mask integration bandwidth = 1.875 MHz to 20 MHz, includes spurs, all V <sub>dd</sub> levels.
<b>Jitter – 5.0 x 3.2 mm and 3.2 x 2.5 mm package</b>						
RMS Period Jitter <sup>[3]</sup>	T <sub>jitt</sub>	–	1.0	1.6	ps	f = 100, 156.25 or 212.5 MHz, V <sub>dd</sub> = 3.3V or 2.5V
RMS Phase Jitter (random)	T <sub>phj</sub>	–	0.230	0.275	ps	f = 156.25 MHz, Integration bandwidth = 12 kHz to 20 MHz, all V <sub>dd</sub> levels, includes spurs, pull range = 100 ppm. Temperature ranges -20 to 70°C and -40 to 85°C.
		–	0.230	0.340	ps	f = 156.25 MHz, Integration bandwidth = 12 kHz to 20 MHz, all V <sub>dd</sub> levels, includes spurs, pull range = 100 ppm. Temperature ranges -40 to 95 °C and -40 to 105°C
		–	0.1	–	ps	f = 156.25 or 322.265625 MHz, IEEE802.3-2005 10GbE jitter mask integration bandwidth = 1.875 MHz to 20 MHz, includes spurs, all V <sub>dd</sub> levels.

**Notes:**

3. Measured according to JESD65B

**Table 5. Pin Description**

Pin	Symbol	Functionality	
1	VIN	Input	Control Voltage
2	NC/OE	No Connect (NC)	No Connect: Leave floating or connect to GND for better heat dissipation. NC for all 3.2 x 2.5 mm package options.
		Output Enable (OE)	H <sup>[4,5]</sup> : specified frequency output L: output is high impedance. Only output driver is disabled. OE function only available on 7050 package. Pin 2 on 3225 package is NC.
3	GND	Power	Vdd Power Supply Ground
4	OUT+	Output	Oscillator output
5	OUT-	Output	Complementary oscillator output
6	Vdd	Power	Power supply voltage <sup>[6]</sup>

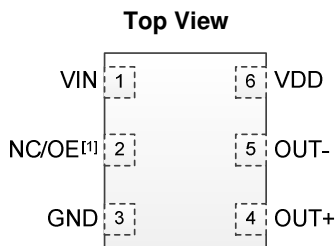

**Figure 1. Pin Assignments (7.0 x 5.0 mm and 5.0 x 3.2 mm packages)**

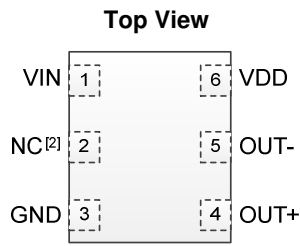

**Figure 2. Pin Assignments (3.2 x 2.5 mm package)**

**Notes:**

4. A pull-up resistor of 10 kΩ or less is recommended if pin 1 is not externally driven.
5. OE mode is only available in the 7050 and 5032 packages. 3225 package is NC.
6. A capacitor of value 0.1 μF or higher between Vdd and GND is required. An additional 10 μF capacitor between Vdd and GND is required for the best phase jitter performance.

**Table 6. Absolute Maximum Ratings**

Attempted operation outside the absolute maximum ratings may cause permanent damage to the part. Actual performance of the IC is only guaranteed within the operational specifications, not at absolute maximum ratings.

Parameter	Min.	Max.	Unit
Vdd	-0.5	4.0	V
V <sub>IH</sub>		Vdd + 0.3V	V
V <sub>IL</sub>	-0.3		V
Storage Temperature	-65	150	°C
Maximum Junction Temperature		130	°C
Soldering Temperature (follow standard Pb-free soldering guidelines)		260	°C

**Table 7. Thermal Considerations<sup>[7]</sup>**

Package	$\theta_{JA}$ , 4 Layer Board (°C/W)	$\theta_{JC}$ , Bottom (°C/W)
3225, 6-pin	80	30
5032, 6-pin	TBD	TBD
7050, 6-pin	52	19

**Notes:**

7. Refer to JESD51 for  $\theta_{JA}$  and  $\theta_{JC}$  definitions, and reference layout used to determine the  $\theta_{JA}$  and  $\theta_{JC}$  values in the above table.

**Table 8. Maximum Operating Junction Temperature<sup>[8]</sup>**

Max Operating Temperature (ambient)	Maximum Operating Junction Temperature
70°C	95°C
85°C	110°C
95°C	120°C
105°C	130°C

**Notes:**

8. Datasheet specifications are not guaranteed if junction temperature exceeds the maximum operating junction temperature.

**Table 9. Environmental Compliance**

Parameter	Test Conditions	Value	Unit
Mechanical Shock Resistance	MIL-STD-883F, Method 2002	10,000	<i>g</i>
Mechanical Vibration Resistance	MIL-STD-883F, Method 2007	70	<i>g</i>
Soldering Temperature (follow standard Pb free soldering guidelines)	MIL-STD-883F, Method 2003	260	°C
Moisture Sensitivity Level	MSL1 @ 260°C		
Electrostatic Discharge (HBM)	HBM, JESD22-A114	2,000	V
Charge-Device Model ESD Protection	JESD220C101	750	V
Latch-up Tolerance	JESD78 Compliant		

### Waveform Diagrams

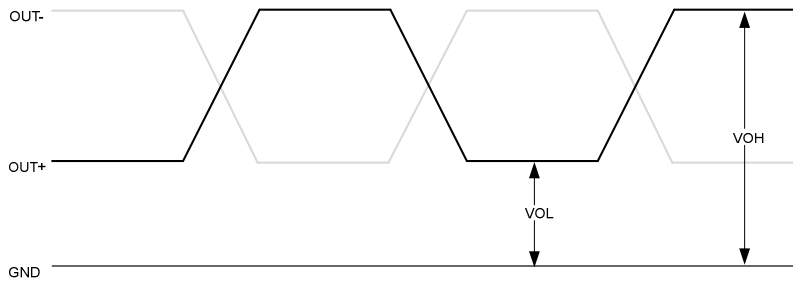

Figure 3. LVPECL/HCSL Voltage Levels per Differential Pin (OUT+/OUT-)

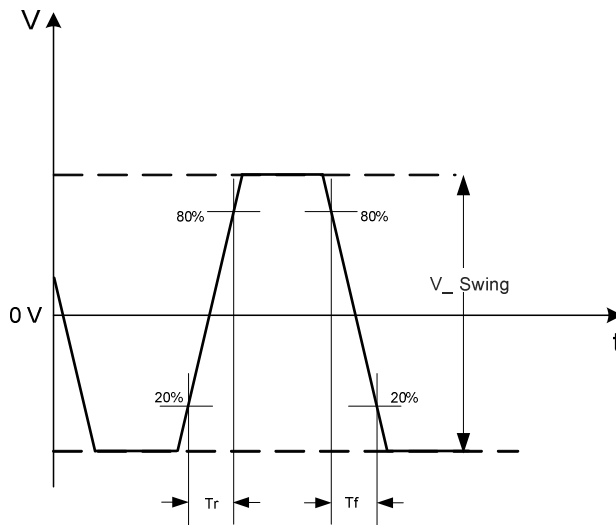

Figure 4. LVPECL/HCSL Voltage Levels across Differential Pair

Waveform Diagrams (continued)

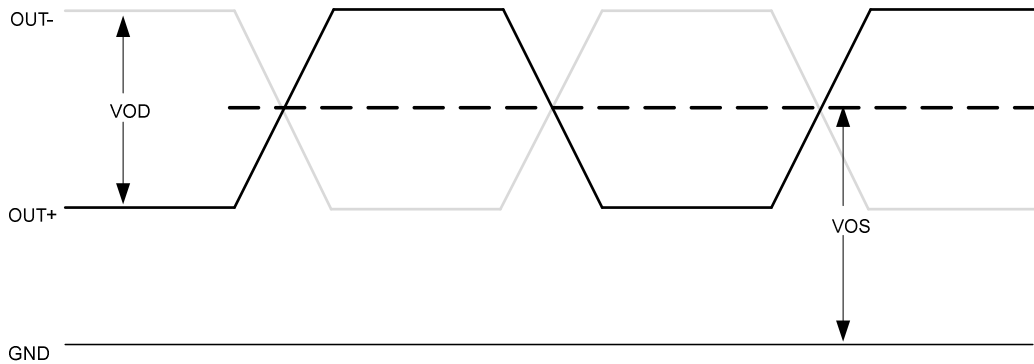

Figure 5. LVDS Voltage Levels per Differential Pin (OUT+/OUT-)

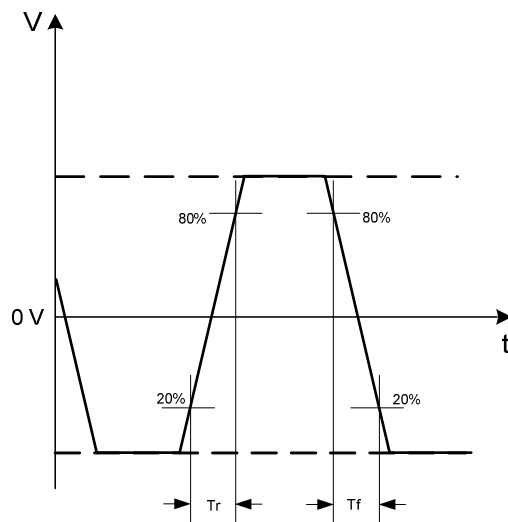

Figure 6. LVDS Differential Waveform

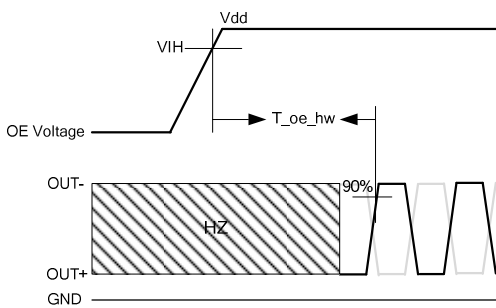

Figure 7. Hardware OE Enable Timing

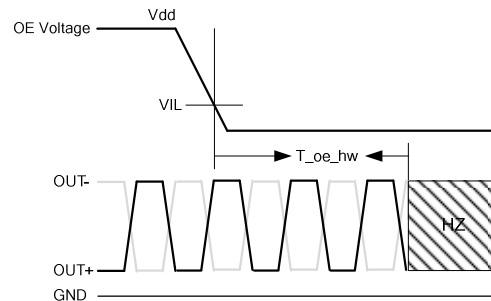

Figure 8. Hardware OE Disable Timing



## Termination Diagrams

LVPECL:

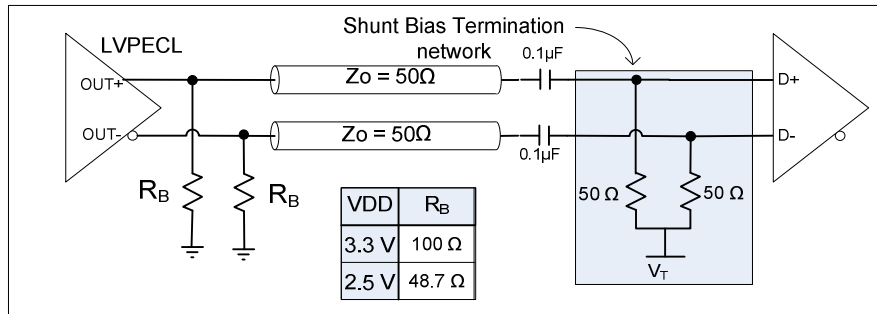

Figure 9. LVPECL with AC-coupled termination

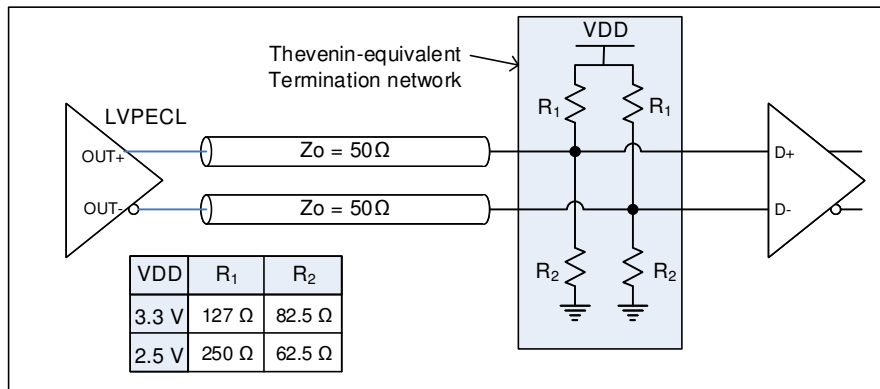

Figure 10. LVPECL DC-coupled load termination with Thevenin equivalent network

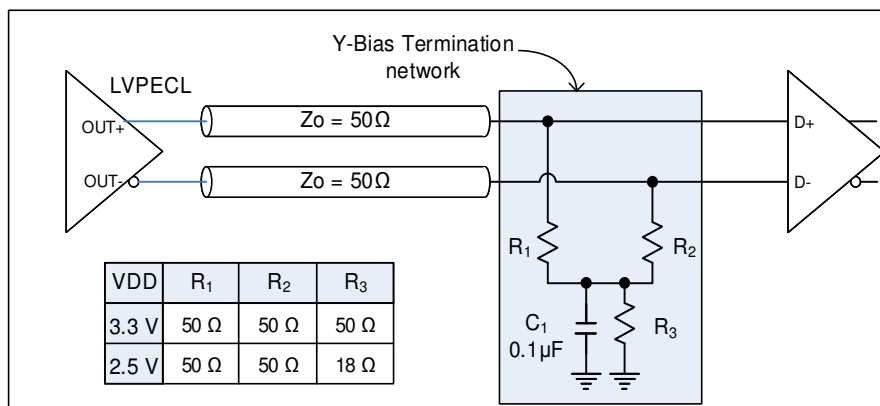

Figure 11. LVPECL with Y-Bias termination

Termination Diagrams (continued)

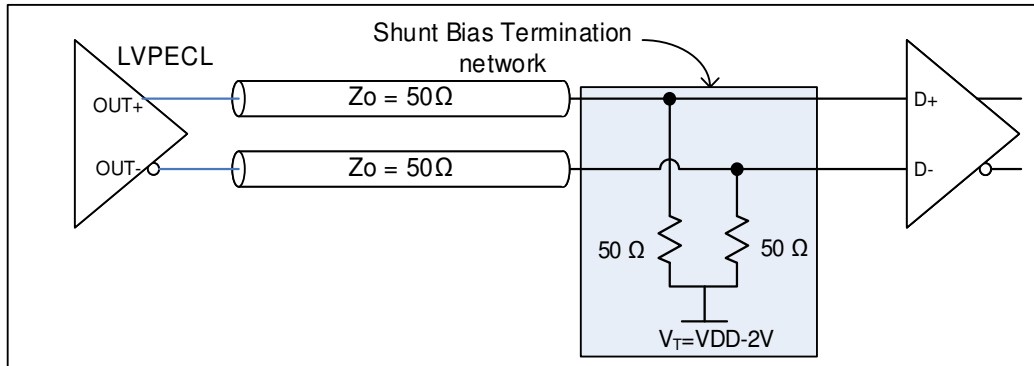

Figure 12. LVPECL with DC-coupled parallel shunt load termination

Termination Diagrams (continued)

LVDS:

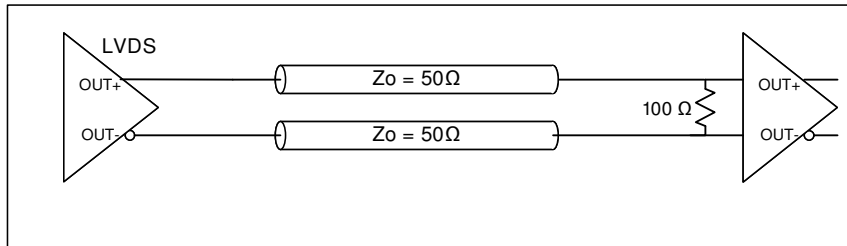

Figure 13. LVDS single DC termination at the load

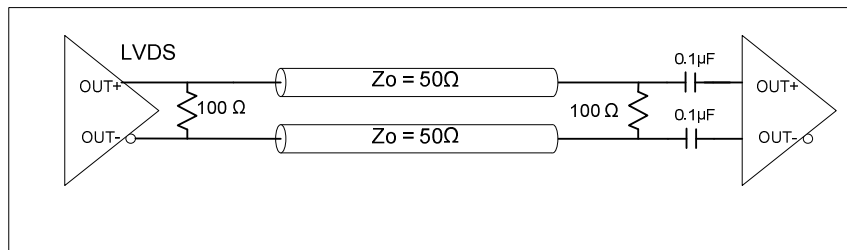

Figure 14. LVDS double AC termination with capacitor close to the load

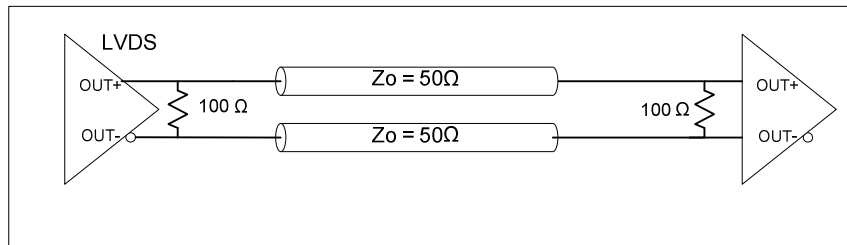

Figure 15. LVDS double DC termination

### Termination Diagrams (continued)

HCSL:

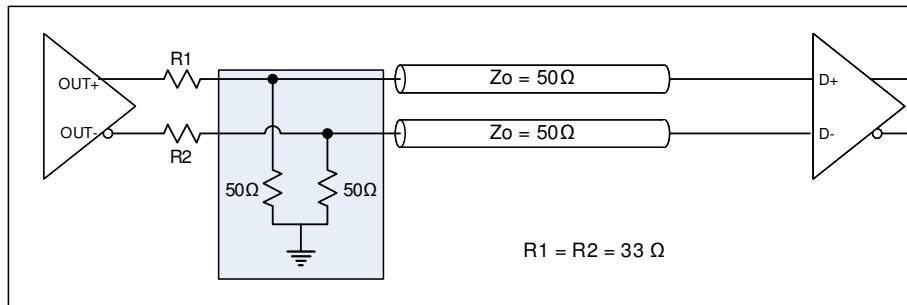
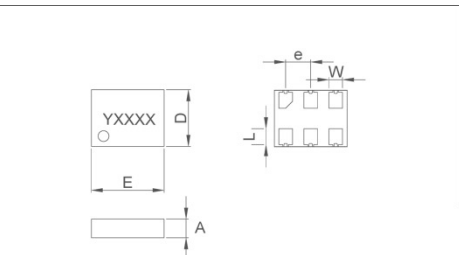

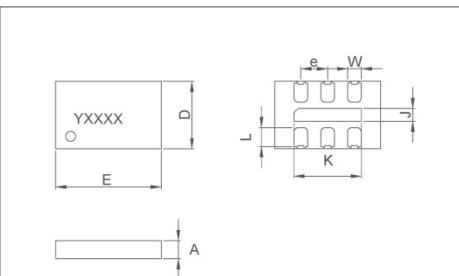
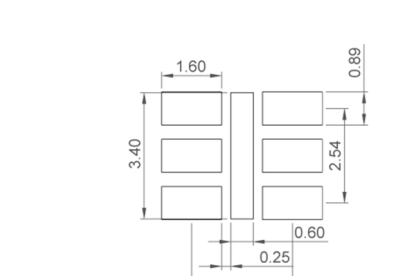
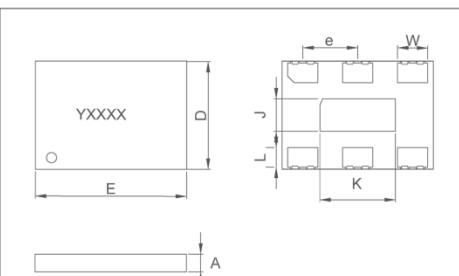
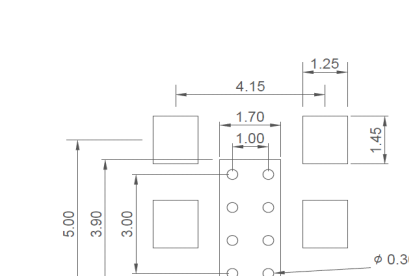

Figure 16. HCSL interface termination

## Dimensions and Patterns

Package Size – Dimensions (Unit: mm) <sup>[9]</sup>	Recommended Land Pattern (Unit: mm) <sup>[10]</sup>																																															
<p><b>3.2 x 2.5 x 0.85 mm</b></p>  <table border="1" data-bbox="617 336 941 546"> <caption>Dimension Table</caption> <thead> <tr> <th></th> <th>Symbol</th> <th>Min</th> <th>Nom</th> <th>Max</th> </tr> </thead> <tbody> <tr> <td>TOTAL THICKNESS</td> <td>A</td> <td>0.800</td> <td>0.850</td> <td>0.900</td> </tr> <tr> <td rowspan="2">BODY SIZE</td> <td>X</td> <td>D</td> <td>2.400</td> <td>2.500</td> <td>2.600</td> </tr> <tr> <td>Y</td> <td>E</td> <td>3.200</td> <td>3.200</td> <td>3.300</td> </tr> <tr> <td>LEAD PITCH</td> <td>e</td> <td colspan="3">1.100 BSC</td> </tr> <tr> <td>LEAD LENGTH</td> <td>L</td> <td>0.650</td> <td>0.700</td> <td>0.750</td> </tr> <tr> <td>LEAD WIDTH</td> <td>W</td> <td>0.550</td> <td>0.600</td> <td>0.650</td> </tr> </tbody> </table> <div style="display: flex; justify-content: space-between; align-items: center; margin-top: 10px;"> <div data-bbox="617 630 763 724"> <p>6L QFN 3.2 x 2.5 x 0.75 mm POD-38 Rev A</p> </div> <div data-bbox="771 630 941 724"> <p>Package Outline </p> </div> </div>		Symbol	Min	Nom	Max	TOTAL THICKNESS	A	0.800	0.850	0.900	BODY SIZE	X	D	2.400	2.500	2.600	Y	E	3.200	3.200	3.300	LEAD PITCH	e	1.100 BSC			LEAD LENGTH	L	0.650	0.700	0.750	LEAD WIDTH	W	0.550	0.600	0.650	<p><b>3.2 x 2.5 x 0.85 mm</b></p> 											
	Symbol	Min	Nom	Max																																												
TOTAL THICKNESS	A	0.800	0.850	0.900																																												
BODY SIZE	X	D	2.400	2.500	2.600																																											
	Y	E	3.200	3.200	3.300																																											
LEAD PITCH	e	1.100 BSC																																														
LEAD LENGTH	L	0.650	0.700	0.750																																												
LEAD WIDTH	W	0.550	0.600	0.650																																												
<p><b>5.0 x 3.2 x 0.85 mm<sup>[11]</sup></b></p>  <table border="1" data-bbox="617 798 941 1050"> <caption>Dimension Table</caption> <thead> <tr> <th></th> <th>Symbol</th> <th>Min</th> <th>Nom</th> <th>Max</th> </tr> </thead> <tbody> <tr> <td>TOTAL THICKNESS</td> <td>A</td> <td>0.800</td> <td>0.850</td> <td>0.900</td> </tr> <tr> <td rowspan="2">BODY SIZE</td> <td>X</td> <td>D</td> <td>3.100</td> <td>3.200</td> <td>3.300</td> </tr> <tr> <td>Y</td> <td>E</td> <td>4.900</td> <td>5.000</td> <td>5.100</td> </tr> <tr> <td rowspan="2">EP SIZE</td> <td>X</td> <td>J</td> <td>0.500</td> <td>0.600</td> <td>0.700</td> </tr> <tr> <td>Y</td> <td>K</td> <td>3.100</td> <td>3.200</td> <td>3.300</td> </tr> <tr> <td>LEAD PITCH</td> <td>e</td> <td colspan="3">1.270 BSC</td> </tr> <tr> <td>LEAD LENGTH</td> <td>L</td> <td>0.850</td> <td>0.900</td> <td>0.950</td> </tr> <tr> <td>LEAD WIDTH</td> <td>W</td> <td>0.590</td> <td>0.640</td> <td>0.690</td> </tr> </tbody> </table> <div style="display: flex; justify-content: space-between; align-items: center; margin-top: 10px;"> <div data-bbox="617 1081 763 1176"> <p>6L QFN 5.0 x 3.2 x 0.85 mm POD-39 Rev A</p> </div> <div data-bbox="771 1081 941 1176"> <p>Package Outline </p> </div> </div>		Symbol	Min	Nom	Max	TOTAL THICKNESS	A	0.800	0.850	0.900	BODY SIZE	X	D	3.100	3.200	3.300	Y	E	4.900	5.000	5.100	EP SIZE	X	J	0.500	0.600	0.700	Y	K	3.100	3.200	3.300	LEAD PITCH	e	1.270 BSC			LEAD LENGTH	L	0.850	0.900	0.950	LEAD WIDTH	W	0.590	0.640	0.690	<p><b>5.0 x 3.2 x 0.85 mm<sup>[11]</sup></b></p> 
	Symbol	Min	Nom	Max																																												
TOTAL THICKNESS	A	0.800	0.850	0.900																																												
BODY SIZE	X	D	3.100	3.200	3.300																																											
	Y	E	4.900	5.000	5.100																																											
EP SIZE	X	J	0.500	0.600	0.700																																											
	Y	K	3.100	3.200	3.300																																											
LEAD PITCH	e	1.270 BSC																																														
LEAD LENGTH	L	0.850	0.900	0.950																																												
LEAD WIDTH	W	0.590	0.640	0.690																																												
<p><b>7.0 x 5.0 x 0.85 mm<sup>[11]</sup></b></p>  <table border="1" data-bbox="617 1302 941 1554"> <caption>Dimension Table</caption> <thead> <tr> <th></th> <th>Symbol</th> <th>Min</th> <th>Nom</th> <th>Max</th> </tr> </thead> <tbody> <tr> <td>TOTAL THICKNESS</td> <td>A</td> <td>0.800</td> <td>0.850</td> <td>0.900</td> </tr> <tr> <td rowspan="2">BODY SIZE</td> <td>X</td> <td>D</td> <td>4.900</td> <td>5.000</td> <td>5.100</td> </tr> <tr> <td>Y</td> <td>E</td> <td>6.900</td> <td>7.000</td> <td>7.100</td> </tr> <tr> <td rowspan="2">EP SIZE</td> <td>X</td> <td>J</td> <td>1.400</td> <td>1.500</td> <td>1.600</td> </tr> <tr> <td>Y</td> <td>K</td> <td>3.400</td> <td>3.500</td> <td>3.600</td> </tr> <tr> <td>LEAD PITCH</td> <td>e</td> <td colspan="3">2.540 BSC</td> </tr> <tr> <td>LEAD LENGTH</td> <td>L</td> <td>0.850</td> <td>0.900</td> <td>0.950</td> </tr> <tr> <td>LEAD WIDTH</td> <td>W</td> <td>1.350</td> <td>1.400</td> <td>1.450</td> </tr> </tbody> </table> <div style="display: flex; justify-content: space-between; align-items: center; margin-top: 10px;"> <div data-bbox="617 1659 763 1753"> <p>6L QFN 7.0 x 5.0 x 0.90 mm POD-37 Rev A</p> </div> <div data-bbox="771 1659 941 1753"> <p>Package Outline </p> </div> </div>		Symbol	Min	Nom	Max	TOTAL THICKNESS	A	0.800	0.850	0.900	BODY SIZE	X	D	4.900	5.000	5.100	Y	E	6.900	7.000	7.100	EP SIZE	X	J	1.400	1.500	1.600	Y	K	3.400	3.500	3.600	LEAD PITCH	e	2.540 BSC			LEAD LENGTH	L	0.850	0.900	0.950	LEAD WIDTH	W	1.350	1.400	1.450	<p><b>7.0 x 5.0 x 0.85 mm<sup>[11]</sup></b></p>  <p><b>Note:</b> Circles in center pad are thermal vias, recommended to improve thermal performance</p>
	Symbol	Min	Nom	Max																																												
TOTAL THICKNESS	A	0.800	0.850	0.900																																												
BODY SIZE	X	D	4.900	5.000	5.100																																											
	Y	E	6.900	7.000	7.100																																											
EP SIZE	X	J	1.400	1.500	1.600																																											
	Y	K	3.400	3.500	3.600																																											
LEAD PITCH	e	2.540 BSC																																														
LEAD LENGTH	L	0.850	0.900	0.950																																												
LEAD WIDTH	W	1.350	1.400	1.450																																												

**Notes:**

9. Top Marking: Y denotes manufacturing origin and XXXX denotes manufacturing lot number. The value of “Y” will depend on the assembly location of the device.
10. A capacitor of value 0.1 μF or higher between Vdd and GND is required. An additional 10 μF capacitor between Vdd and GND is required for the best phase jitter performance
11. The center pad has no electrical function. Soldering down the center pad to the GND is recommended for best thermal dissipation, but is optional.

## Ordering Information

### SiT3372AC-1B2-33NH122.123456T

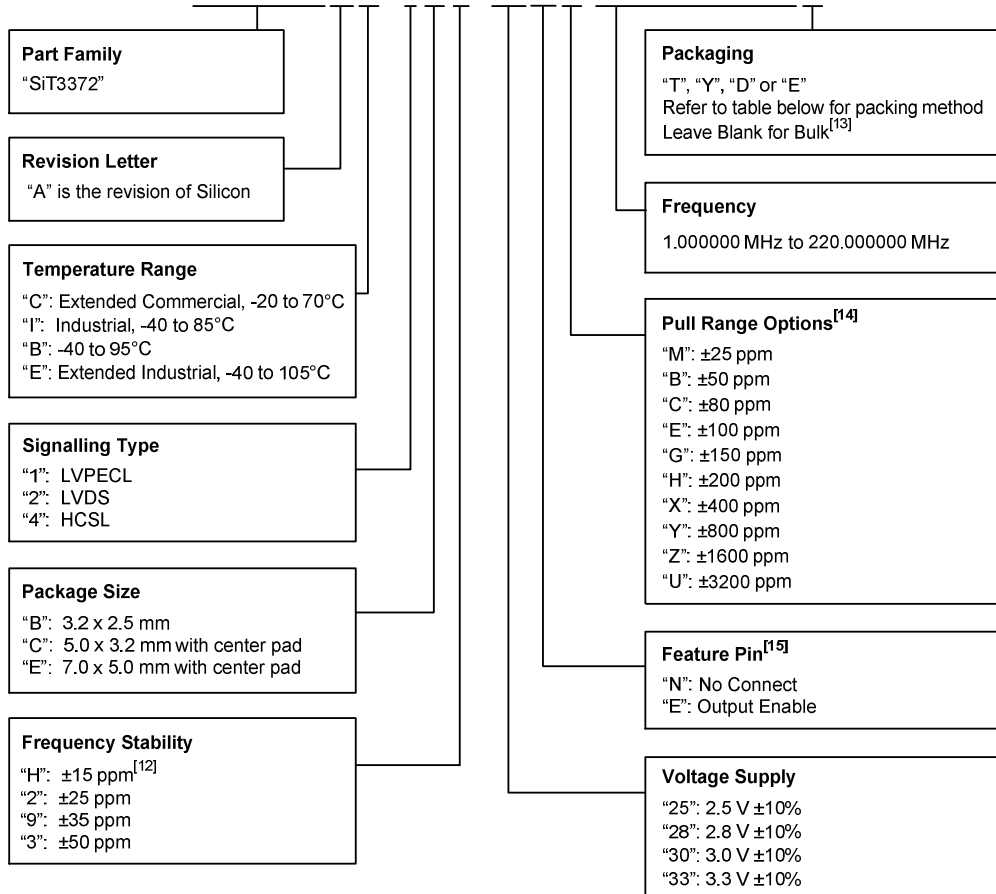

**Notes:**

- 12. Contact [SiTime](#) for ±15 ppm
- 13. Bulk is available for sampling only
- 14. Contact [SiTime](#) for custom pull range options
- 15. "E": Output Enable function is only available in 7.0 x 5.0 mm and 5.0 x 3.2 mm packages

**Table 10. Ordering Codes for Supported Tape & Reel Packing Method**

Device Size (mm x mm)	8 mm T&R (3ku)	8 mm T&R (1ku)	12 mm T&R (3ku)	12 mm T&R (1ku)	16 mm T&R (3ku)	16 mm T&R (1ku)
7.0 x 5.0	—	—	—	—	T	Y
5.0 x 3.2	—	—	T	Y	—	—
3.2 x 2.5	D	E	T	Y	—	—

**Table 11. APR Table**

Absolute pull range (APR) = Nominal pull range (PR) - frequency stability (F\_stab)-aging

Nominal Pull Range	Frequency Stability			
	± 15	± 25	± 35	± 50
	APR (ppm)			
± 25	± 5	—	—	—
± 50	± 30	± 20	± 10	—
± 80	± 60	± 50	± 40	± 25
± 100	± 80	± 70	± 60	± 45
± 150	± 130	± 120	± 110	± 95
± 200	± 180	± 170	± 160	± 145
± 400	± 380	± 370	± 360	± 345
± 800	± 780	± 770	± 760	± 745
± 1600	± 1580	± 1570	± 1560	± 1545
± 3200	± 3180	± 3170	± 3160	± 3145

**Table 12. Additional Information**

Document	Description	Download Link
<b>ECCN #: EAR99</b>	Five character designation used on the commerce Control List (CCL) to identify dual use items for export control purposes.	—
<b>Part number Generator</b>	Tool used to create the part number based on desired features.	—
<b>Manufacturing Notes</b>	Tape & Reel dimension, reflow profile and other manufacturing related info	<a href="http://www.sitime.com/manufacturing-notes">http://www.sitime.com/manufacturing-notes</a>
<b>Product Qualification report</b>	Device reliability report	<a href="https://www.sitime.com/sites/default/files/gated/RR45_Third%20Generation%20DEXO%2C%20VCXO%20Product%20Qualification%20Report_A01.pdf">https://www.sitime.com/sites/default/files/gated/RR45_Third%20Generation%20DEXO%2C%20VCXO%20Product%20Qualification%20Report_A01.pdf</a>
<b>Environmental Reports</b>	RoHS report	<a href="https://www.sitime.com/sites/default/files/gated/QI-86_RoHSCert_Third Generation DEXO, VCXO Package_Homogeneous_Materials_A00.pdf">https://www.sitime.com/sites/default/files/gated/QI-86_RoHSCert_Third Generation DEXO, VCXO Package_Homogeneous_Materials_A00.pdf</a>
<b>Composition report</b>	Get from Robin	<a href="https://www.sitime.com/sites/default/files/gated/QI-87%20Third%20Generation%20DEXO%2C%20VCXO%20Composition%20Report_A01_0.pdf">https://www.sitime.com/sites/default/files/gated/QI-87%20Third%20Generation%20DEXO%2C%20VCXO%20Composition%20Report_A01_0.pdf</a>
<b>Performance Reports</b>	Additional performance data such as phase noise, current consumption and jitter for selected frequencies	<a href="http://www.sitime.com/support/performance-measurement-report">http://www.sitime.com/support/performance-measurement-report</a>
<b>Termination Techniques</b>	Termination design recommendations	<a href="http://www.sitime.com/support/application-notes">http://www.sitime.com/support/application-notes</a>
<b>Layout Techniques</b>	Layout recommendations	<a href="http://www.sitime.com/support/application-notes">http://www.sitime.com/support/application-notes</a>

Table 13. Revision History

Revision	Release Date	Change Summary
1.0	10/13/2017	Initial release
1.03	05/10/2018	Updated the Part Ordering info with added 5.0 x 3.2 mm package

**SiTime Corporation, 5451 Patrick Henry Drive, Santa Clara, CA 95054, USA | Phone: +1-408-328-4400 | Fax: +1-408-328-4439**

© SiTime Corporation 2017-2018. The information contained herein is subject to change at any time without notice. SiTime assumes no responsibility or liability for any loss, damage or defect of a Product which is caused in whole or in part by (i) use of any circuitry other than circuitry embodied in a SiTime product, (ii) misuse or abuse including static discharge, neglect or accident, (iii) unauthorized modification or repairs which have been soldered or altered during assembly and are not capable of being tested by SiTime under its normal test conditions, or (iv) improper installation, storage, handling, warehousing or transportation, or (v) being subjected to unusual physical, thermal, or electrical stress.

**Disclaimer:** SiTime makes no warranty of any kind, express or implied, with regard to this material, and specifically disclaims any and all express or implied warranties, either in fact or by operation of law, statutory or otherwise, including the implied warranties of merchantability and fitness for use or a particular purpose, and any implied warranty arising from course of dealing or usage of trade, as well as any common-law duties relating to accuracy or lack of negligence, with respect to this material, any SiTime product and any product documentation. Products sold by SiTime are not suitable or intended to be used in a life support application or component, to operate nuclear facilities, or in other mission critical applications where human life may be involved or at stake. All sales are made conditioned upon compliance with the critical uses policy set forth below.

**CRITICAL USE EXCLUSION POLICY**

BUYER AGREES NOT TO USE SITIME'S PRODUCTS FOR ANY APPLICATION OR IN ANY COMPONENTS USED IN LIFE SUPPORT DEVICES OR TO OPERATE NUCLEAR FACILITIES OR FOR USE IN OTHER MISSION-CRITICAL APPLICATIONS OR COMPONENTS WHERE HUMAN LIFE OR PROPERTY MAY BE AT STAKE.

SiTime owns all rights, title and interest to the intellectual property related to SiTime's products, including any software, firmware, copyright, patent, or trademark. The sale of SiTime products does not convey or imply any license under patent or other rights. SiTime retains the copyright and trademark rights in all documents, catalogs and plans supplied pursuant to or ancillary to the sale of products or services by SiTime. Unless otherwise agreed to in writing by SiTime, any reproduction, modification, translation, compilation, or representation of this material shall be strictly prohibited.



Компания «Океан Электроники» предлагает заключение долгосрочных отношений при поставках импортных электронных компонентов на взаимовыгодных условиях!

Наши преимущества:

- Поставка оригинальных импортных электронных компонентов напрямую с производств Америки, Европы и Азии, а так же с крупнейших складов мира;
- Широкая линейка поставок активных и пассивных импортных электронных компонентов (более 30 млн. наименований);
- Поставка сложных, дефицитных, либо снятых с производства позиций;
- Оперативные сроки поставки под заказ (от 5 рабочих дней);
- Экспресс доставка в любую точку России;
- Помощь Конструкторского Отдела и консультации квалифицированных инженеров;
- Техническая поддержка проекта, помощь в подборе аналогов, поставка прототипов;
- Поставка электронных компонентов под контролем ВП;
- Система менеджмента качества сертифицирована по Международному стандарту ISO 9001;
- При необходимости вся продукция военного и аэрокосмического назначения проходит испытания и сертификацию в лаборатории (по согласованию с заказчиком);
- Поставка специализированных компонентов военного и аэрокосмического уровня качества (Xilinx, Altera, Analog Devices, Intersil, Interpoint, Microsemi, Actel, Aeroflex, Peregrine, VPT, Syfer, Eurofarad, Texas Instruments, MS Kennedy, Miteq, Cobham, E2V, MA-COM, Hittite, Mini-Circuits, General Dynamics и др.);

Компания «Океан Электроники» является официальным дистрибьютором и эксклюзивным представителем в России одного из крупнейших производителей разъемов военного и аэрокосмического назначения «JONHON», а так же официальным дистрибьютором и эксклюзивным представителем в России производителя высокотехнологичных и надежных решений для передачи СВЧ сигналов «FORSTAR».



## JONHON

«JONHON» (основан в 1970 г.)

Разъемы специального, военного и аэрокосмического назначения:

(Применяются в военной, авиационной, аэрокосмической, морской, железнодорожной, горно- и нефтедобывающей отраслях промышленности)

«FORSTAR» (основан в 1998 г.)

ВЧ соединители, коаксиальные кабели, кабельные сборки и микроволновые компоненты:

(Применяются в телекоммуникациях гражданского и специального назначения, в средствах связи, РЛС, а так же военной, авиационной и аэрокосмической отраслях промышленности).



Телефон: 8 (812) 309-75-97 (многоканальный)

Факс: 8 (812) 320-03-32

Электронная почта: [ocean@oceanchips.ru](mailto:ocean@oceanchips.ru)

Web: <http://oceanchips.ru/>

Адрес: 198099, г. Санкт-Петербург, ул. Калинина, д. 2, корп. 4, лит. А