

Features

- **Precision Programmable Threshold Monitors, Threshold Accuracy 0.7%**
 - Simultaneously monitors up to six power supplies
 - Programmable analog trip points (1% step size; 192 steps)
 - Programmable glitch filter
 - Power-off detection (75mV)
- **Embedded Programmable Timers**
 - Four independent timers
 - 32µs to 2 second intervals for timing sequences
- **Embedded PLD for Logical Control**
 - Rugged 16-macrocell CPLD architecture
 - 81 product terms / 28 inputs
 - Implements state machines and combinatorial functions
- **Power-Down Mode I_{CC} < 10µA**
- **Digital I/O**
 - Two dedicated digital inputs
 - Five programmable digital I/O pins
- **Wide Supply Range (2.64V to 3.96V)**
 - In-system programmable through JTAG
 - Industrial temperature range: -40°C to +85°C
 - 24-pin QFN package, lead-free option

Description

Lattice's Power Manager II ProcessorPM-POWR605 is a general-purpose power-supply monitor, reset generator and watchdog timer, incorporating both in-system programmable logic and analog functions implemented in non-volatile E²CMOS[®] technology. The ProcessorPM-POWR605 device provides six independent analog input channels to monitor power supply voltages. Two general-purpose digital inputs are also provided for miscellaneous control functions.

The ProcessorPM-POWR605 provides up to five open drain digital outputs that can be used for controlling DC-DC converters, low-drop-out regulators (LDOs) and optocouplers, as well as for supervisory and general-purpose logic interface functions. The five digital, open drain outputs can optionally be configured as digital inputs to sense more input signals as needed, such as manual reset, etc.

Application Block Diagram

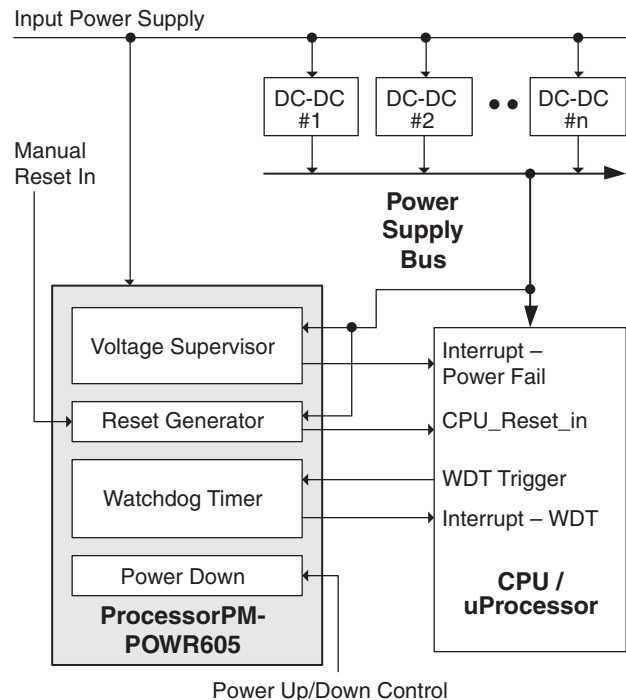

The diagram above shows how a ProcessorPM-POWR605 is used in a typical application. It controls power to the microprocessor system, generates the CPU reset and monitors critical power supply voltages, generating interrupts whenever faults are detected. It also provides a watchdog timer function to detect CPU operating and bus timeout errors.

The ProcessorPM-POWR605 incorporates a 16-macrocell CPLD. Figure 1 shows the analog input comparators and digital inputs used as inputs to the CPLD array. The digital output pins providing the external control signals are driven by the CPLD. Four independently programmable timers also interface with the CPLD and can create delays and time-outs ranging from 32µs to 2 seconds. The CPLD is programmed using LogiBuilder™, an easy-to-learn language integrated into the PAC-Designer[®] software. Control sequences are written to monitor the status of any of the analog input channel comparators or the digital inputs.

Figure 1. ProcessorPM-POWR605 Block Diagram

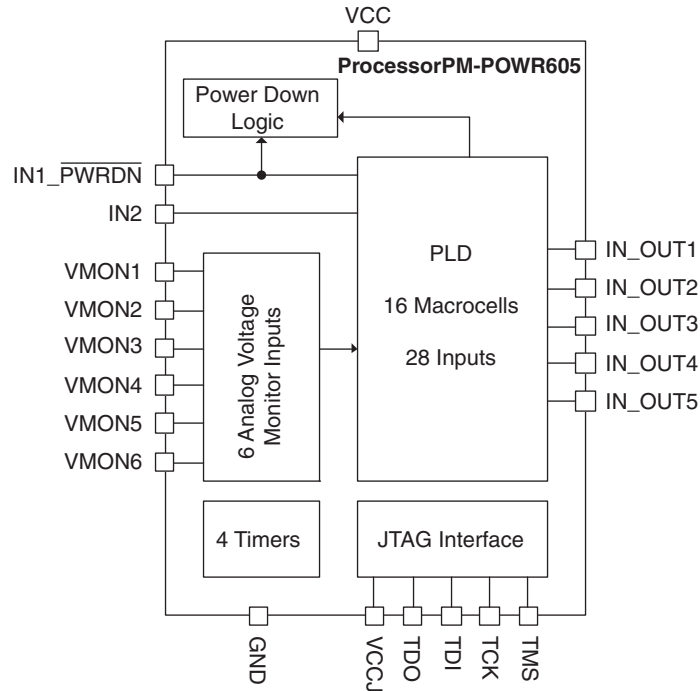

Pin Descriptions

| Number | Name | Pin Type | Voltage Range | Description |
|--------|-----------|--------------------------------|----------------------------|--|
| 8, 9 | GND | Ground | Ground | Ground ¹ |
| 20 | IN_OUT1 | Digital Input ^{9, 10} | 0V to 5.5V | PLD Input 3 |
| | | Open Drain Output ² | | Open Drain Output 3 |
| 19 | IN_OUT2 | Digital Input ^{9, 10} | 0V to 5.5V | PLD Input 4 |
| | | Open Drain Output ² | | Open Drain Output 4 |
| 18 | IN_OUT3 | Digital Input ^{9, 10} | 0V to 5.5V | PLD Input 5 |
| | | Open Drain Output ² | | Open Drain Output 5 |
| 17 | IN_OUT4 | Digital Input ^{9, 10} | 0V to 5.5V | PLD Input 6 |
| | | Open Drain Output ² | | Open Drain Output 6 |
| 15 | IN_OUT5 | Digital Input ^{9, 10} | 0V to 5.5V | PLD Input 7 |
| | | Open Drain Output ² | | Open Drain Output 7 |
| 22 | IN1_PWRDN | Digital Input ¹⁰ | 0V to 5.5V ³ | PLD Logic Input 1. ^{4, 5} When not used, this pin should be pulled down with a 10kΩ resistor. |
| 21 | IN2 | Digital Input ¹⁰ | 0V to 5.5V ³ | PLD Logic Input 2. When not used, this pin should be tied to GND. |
| 12 | TCK | Digital Input | 0V to 5.5V | JTAG Test Clock Input |
| 13 | TDI | Digital Input | 0V to 5.5V | JTAG Test Data In - Internal Pull-up |
| 11 | TDO | Digital Output | 0V to 5.5V | JTAG Test Data Out |
| 14 | TMS | Digital Input | 0V to 5.5V | JTAG Test Mode Select - Internal Pull-up |
| 3, 16 | VCC | Power | 2.64V to 3.96V | Power Supply ⁶ |
| 10 | VCCJ | Power | 2.25V to 3.6V | VCC for JTAG Logic Interface Pins ⁷ |
| 1 | VMON1 | Analog Input | -0.3V to 5.9V ⁸ | Voltage Monitor Input 1 |
| 2 | VMON2 | Analog Input | -0.3V to 5.9V ⁸ | Voltage Monitor Input 2 |

Pin Descriptions (Cont.)

| Number | Name | Pin Type | Voltage Range | Description |
|---------|-------|---------------|----------------------------|-------------------------|
| 4 | VMON3 | Analog Input | -0.3V to 5.9V ⁸ | Voltage Monitor Input 3 |
| 5 | VMON4 | Analog Input | -0.3V to 5.9V ⁸ | Voltage Monitor Input 4 |
| 6 | VMON5 | Analog Input | -0.3V to 5.9V ⁸ | Voltage Monitor Input 5 |
| 7 | VMON6 | Analog Input | -0.3V to 5.9V ⁸ | Voltage Monitor Input 6 |
| 23, 24 | NC | No Connection | Not applicable | No internal connection |
| Die Pad | NC | No Connection | Not applicable | No internal connection |

- GND pins must be connected together on the circuit board.
- Open-drain outputs require an external pull-up resistor to a supply.
- IN1_PWRDN and IN2 are inputs to the PLD. The thresholds for these pins are referenced by the voltage on VCC.
- The power-down function is E²C MOS programmable and when enabled is input level sensitive (enter power-down mode = low; exit power-down mode = high).
- Source of the power-down initiation can be assigned to either the IN1_PWRDN pin or to an internally generated PLD output signal called PLD_PWRDN. When generated internally by the PLD, the IN1_PWRDN pin is only used to exit power-down mode (IN1_PWRDN pin = high).
- VCC pins must be connected together on the circuit board.
- In power-down mode, VCCJ is internally pulled to GND to turn off the JTAG I/O pins. It is important, therefore, that the VCCJ pin be open whenever power-down mode is initiated. If connected to a power supply during power-down mode, VCCJ will draw approximately 2.2mA.
- The VMON inputs can be biased independently from VCC. Connect unused VMONs to 3.3V rail.
- Thresholds of IN_OUT1...IN_OUT5 in the input mode are referenced by the voltage on VCC.
- IN1_PWRDN, IN2 and IN_OUT1...IN_OUT5 pins configured as inputs are clocked by the internal MCLK signal.

Figure 2. Reset Generator Programmable Pulse Stretch and Watchdog Timer Programmable Up to One Minute (Initial Factory Configuration)¹

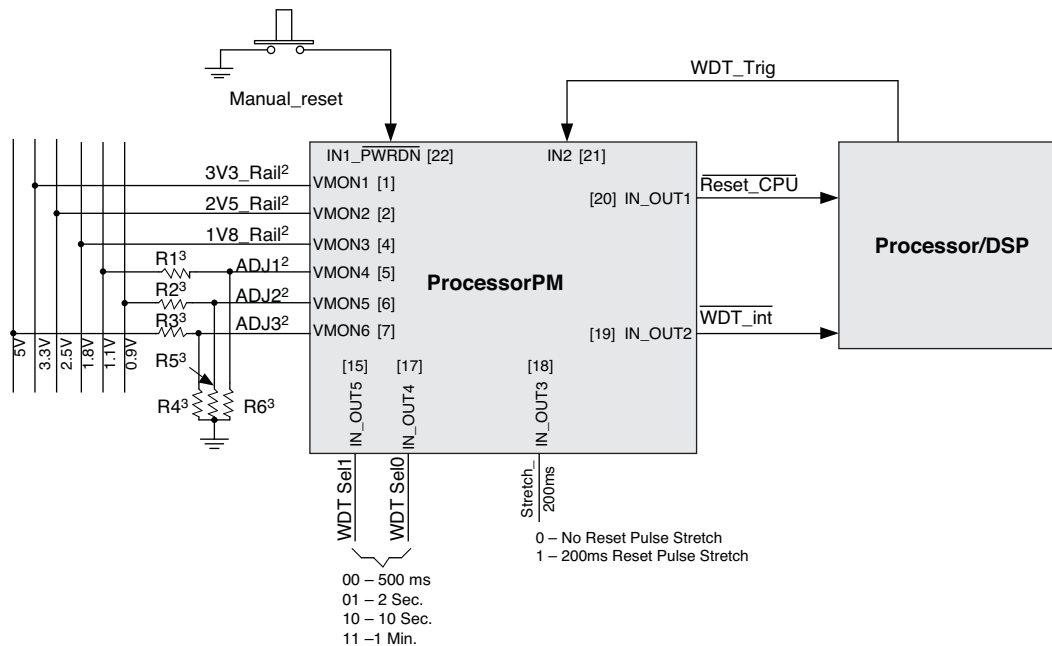

- Pin numbers shown in brackets.
- Connect unused VMONs to 3.3V rail.
- R1..R6 required to externally adjust fault threshold when using factory default configuration. For supply rails <5.7V, R1..R6 are not required if fault thresholds are programmed into the ProcessorPM.

Absolute Maximum Ratings

Absolute maximum ratings are shown in the table below. Stresses beyond those listed may cause permanent damage to the device. Functional operation of the device at these or any other conditions beyond those indicated in the recommended operating conditions of this specification is not implied.

| Symbol | Parameter | Conditions | Min. | Max. | Units |
|---------------|--|-------------|------|------|-------|
| V_{CC} | Core supply | | -0.5 | 4.5 | V |
| V_{CCJ} | JTAG logic supply | | -0.5 | 6 | V |
| V_{IN} | Digital input voltage (all digital I/O pins) | | -0.5 | 6 | V |
| V_{MON} | V_{MON} input voltage | | -0.5 | 6 | V |
| V_{TRI} | Voltage applied to tri-stated pins | IN_OUT[1:5] | -0.5 | 6 | V |
| T_S | Storage temperature | | -65 | 150 | °C |
| T_A | Ambient temperature | | -65 | 125 | °C |
| $I_{SINKMAX}$ | Maximum sink current on any output | | | 23 | mA |

Recommended Operating Conditions

| Symbol | Parameter | Conditions | Min. | Max. | Units |
|-----------|-------------------------------------|------------------|------|------|-------|
| V_{CC} | Core supply voltage at pin | | 2.64 | 3.96 | V |
| V_{CCJ} | JTAG logic supply voltage at pin | | 2.25 | 3.6 | V |
| V_{IN} | Input voltage at digital input pins | | -0.3 | 5.5 | V |
| V_{MON} | Input voltage at V_{MON} pins | | -0.3 | 5.9 | V |
| V_{OUT} | Open-drain output voltage | IN_OUT[1:5] pins | -0.3 | 5.5 | V |
| T_A | Ambient temperature | Power applied | -40 | 85 | °C |
| T_{JOP} | Operating junction temperature | Power applied | -40 | 90 | °C |

Analog Specifications

| Symbol | Parameter | Conditions | Min. | Typ. | Max. | Units |
|-------------------|--------------------------------|---|------|------|------|-------|
| I_{CC}^1 | Supply current | | | 3.5 | 5 | mA |
| I_{CCJ}^2 | Supply current | | | | 1 | mA |
| $I_{CC_PWRDN}^3$ | Power-down mode supply current | ICC + pin leakage currents ² | | | 10 | μA |

1. Includes currents on both V_{CC} pins.
2. In power-down mode, V_{CCJ} is internally pulled to GND to turn off the JTAG I/O pins. It is important, therefore, that the V_{CCJ} pin be open whenever power-down mode is initiated. If connected to a power supply during power-down mode, V_{CCJ} will draw approximately 2.2mA.
3. Leakage measured in power-down mode with applied pin voltages as follows: $V_{CC} = 3.96V$; $IN1_PWRDN$, GND = 0V; $IN2$, V_{MONx} and $IN_OUTx = 5.5V$; V_{CCJ} , TDI, TDO, TMS and TCK = open.

Voltage Monitors

| Symbol | Parameter | Conditions | Min. | Typ. | Max. | Units |
|------------------------------|--|------------------------|-------|------|-------|-------|
| R _{IN} | Input resistance | | 55 | 65 | 75 | kΩ |
| C _{IN} | Input capacitance | | | 8 | | pF |
| V _{MON} Range | Programmable trip-point range | | 0.075 | | 5.793 | V |
| V _Z Sense | Near-ground sense threshold | | 70 | 75 | 80 | mV |
| V _{MON} Accuracy | Absolute accuracy of any trip-point ⁺ | 25°C, trip point <2.7V | | | 0.7 | % |
| | | 25°C, trip point >2.7V | | | 0.8 | % |
| T _{EMPCO_THRESHOLD} | Threshold temperature coefficient | | | 60 | | ppm/c |
| HYST | Hysteresis of any trip-point (relative to setting) | | | 1 | | % |

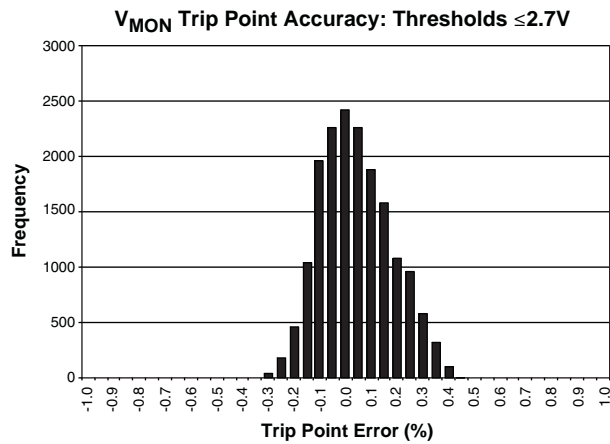

Threshold setting accuracy histogram for all trip points ≤2.7V.

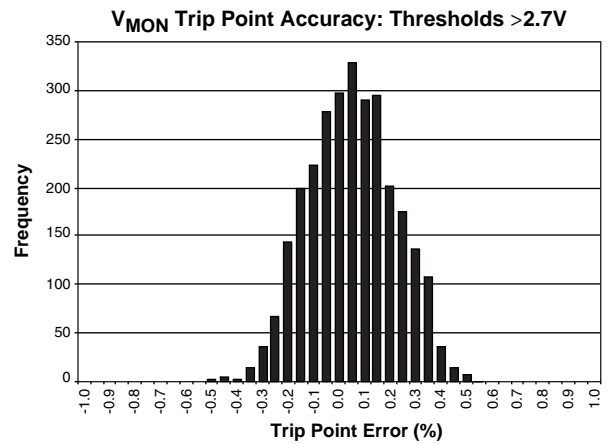

Threshold setting accuracy histogram for all trip points >2.7V.

Power-On Reset (Internal)

| Symbol | Parameter | Conditions | Min. | Typ. | Max. | Units |
|-------------|--|------------|------|------|------|---------|
| T_{RST} | Delay from V_{TH} to start-up state | | | | 100 | μs |
| T_{START} | Duration of start-up state | | | | 300 | μs |
| T_{BRO} | Minimum duration brown out required to enter reset state | | 1 | | 5 | μs |
| T_{POR} | Delay from brown out to reset state | | | | 7 | μs |
| V_{TL} | Threshold below which POR is LOW ¹ | | | | 2.2 | V |
| V_{TH} | Threshold above which POR is HIGH ¹ | | 2.5 | | | V |
| V_T | Threshold above which POR is valid ¹ | | 0.8 | | | V |

1. Corresponds to VCC supply voltage.

Figure 3. Internal Power-On Reset

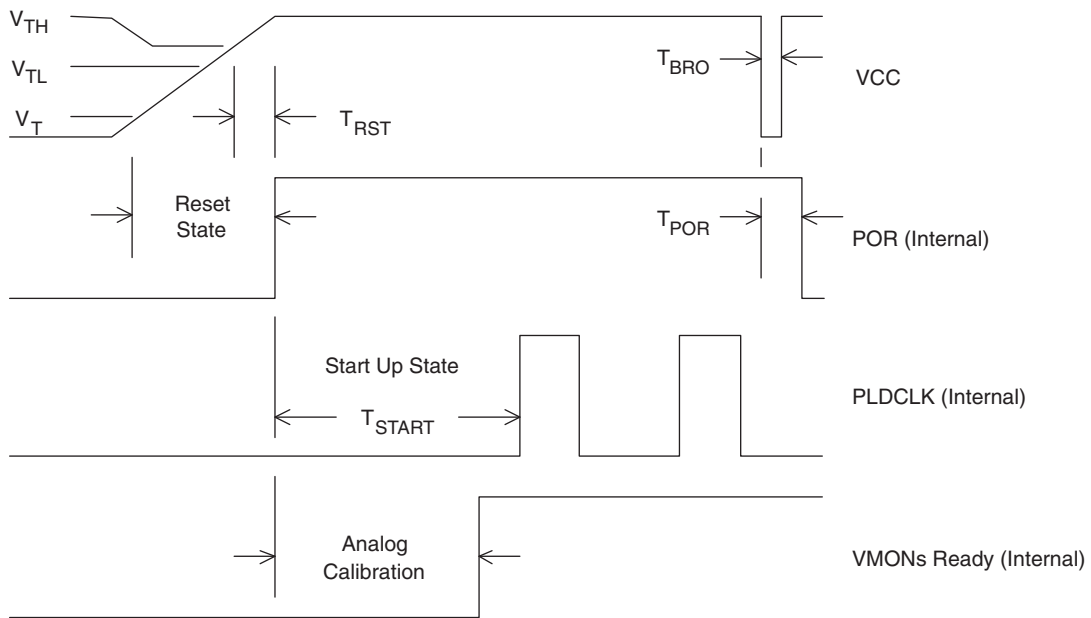

AC/Transient Characteristics

Over Recommended Operating Conditions

| Symbol | Parameter | Conditions | Min. | Typ. | Max. | Units |
|-------------------------|--|------------------------------|-------|------|-------|---------------|
| Voltage Monitors | | | | | | |
| t_{PD12} | Propagation delay input to output glitch filter OFF | | | 12 | | μs |
| t_{PD48} | Propagation delay input to output glitch filter ON | | | 48 | | μs |
| Oscillators | | | | | | |
| f_{MCLK} | MCLK timing | | 7.6 | 8.0 | 8.4 | MHz |
| f_{PLDCLK} | PLDCLK frequency = MCLK \div 32 | | | 250 | | kHz |
| Timers | | | | | | |
| Timeout Range | Range of programmable timers (128 steps) | | 0.032 | | 1966 | ms |
| Resolution | Spacing between available adjacent timer intervals | | | | 13 | % |
| Accuracy | Timer accuracy | $f_{MCLK} = 8.0 \text{ MHz}$ | -6.67 | | -12.5 | % |
| Power-Down Mode | | | | | | |
| T_{PWRDN} | Time to enter power-down mode | Device previously on | 100 | | | μs |
| T_{PWRDN_HOLD} | Minimum required time in power-down mode before power-up can occur | | 100 | | | μs |
| T_{PWRUP} | Time to exit power-down mode | | 300 | | | μs |
| T_{PWRDN_UP} | Total time to enter and then exit power-down mode | | 500 | | | μs |

Figure 4. Power-Down Mode Timing

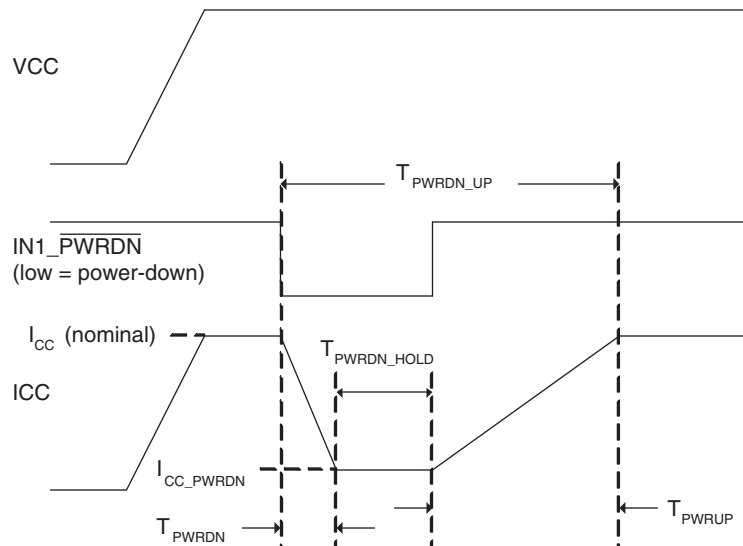

Digital Specifications

Over Recommended Operating Conditions

| Symbol | Parameter | Conditions | Min. | Typ. | Max. | Units |
|------------------------------|--|---|------|------|----------------|---------|
| I_{IL}, I_{IH} | Input leakage, no pull-up/pull-down | | | | +/-10 | μA |
| I_{PU} | Input pull-up current (TMS, TDI) | | | 70 | | μA |
| V_{IL} | Voltage input, logic low ¹ | TDI, TMS, TCK, IN[1:2], IN_OUT[1:5] ² , V _{CCJ} = 3.3V supply | | | 0.8 | V |
| | | TDI, TMS, TCK, V _{CCJ} = 2.5V supply | | | 0.7 | |
| V_{IH} | Voltage input, logic high ¹ | TDI, TMS, TCK, IN[1:2], IN_OUT[1:5] ² , V _{CCJ} = 3.3V supply | 2.0 | | | V |
| | | TDI, TMS, TCK, V _{CCJ} = 2.5V supply | 1.7 | | | |
| V_{OL} | IN_OUT[1:5] ³ | $I_{SINK} = 20mA$ | | | 0.8 | V |
| | TDO | $I_{SINK} = 4mA$ | | | 0.4 | |
| V_{OH} | TDO | $I_{SRC} = 4mA$ | | | $V_{CC} - 0.4$ | V |
| I_{SINK} | Output sink current per digital output IN_OUT[1:5] | $V_{OL} < 0.8V$ | | | 20 | mA |
| | | Chip powered down, outputs pulled up to 3.6V | | <1 | | μA |
| $I_{SINKTOTAL}$ ⁴ | All digital outputs | | | | 67 | mA |

1. IN_OUT[1:5], IN[1:2] referenced to V_{CC}; TDO, TDI, TMS, and TCK referenced to V_{CCJ}.

2. When configured as inputs.

3. When configured as open drain outputs.

4. Sum of maximum current sink from all digital outputs combined. Reliable operation is not guaranteed if this value is exceeded.

Figure 5. ProcessorPM Digital Output, V_{OL} vs. I_{SINK} Characteristics

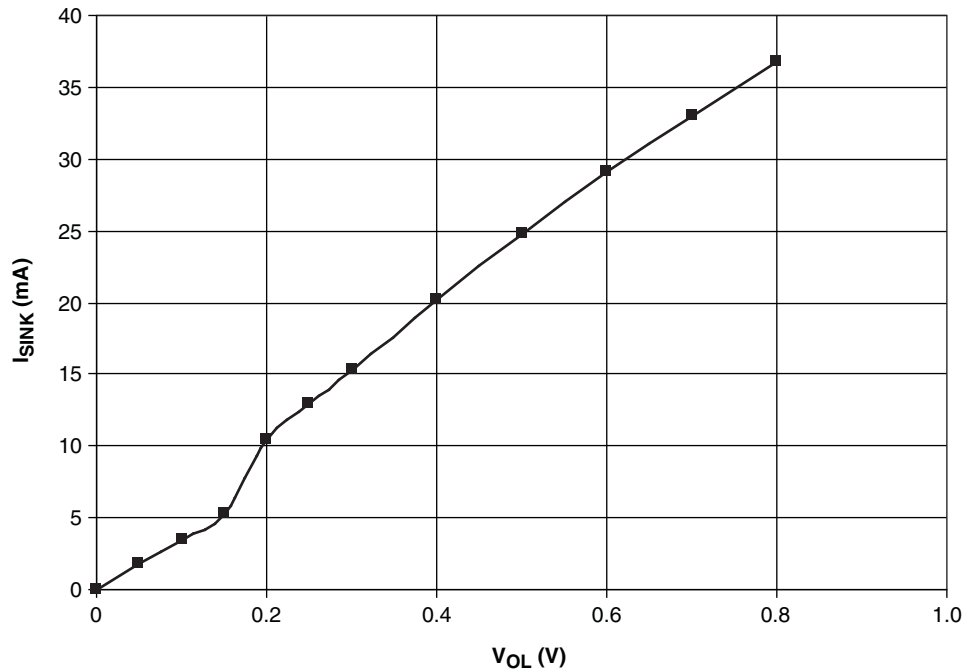

Timing for JTAG Operations

| Symbol | Parameter | Conditions | Min. | Typ. | Max. | Units |
|--------------------|--------------------------------------|------------|------|------|------|---------------|
| t_{SPEN} | Program enable delay time | | 10 | — | — | μs |
| t_{SPDIS} | Program disable delay time | | 30 | — | — | μs |
| t_{HVDIS} | High voltage discharge time, program | | 30 | — | — | μs |
| t_{HVDIS} | High voltage discharge time, erase | | 200 | — | — | μs |
| t_{CEN} | Falling edge of TCK to TDO active | | — | — | 10 | ns |
| t_{CDIS} | Falling edge of TCK to TDO disable | | — | — | 10 | ns |
| t_{SU1} | Setup time | | 5 | — | — | ns |
| t_{H} | Hold time | | 10 | — | — | ns |
| t_{CKH} | TCK clock pulse width, high | | 20 | — | — | ns |
| t_{CKL} | TCK clock pulse width, low | | 20 | — | — | ns |
| f_{MAX} | Maximum TCK clock frequency | | — | — | 25 | MHz |
| t_{CO} | Falling edge of TCK to valid output | | — | — | 10 | ns |
| t_{PWV} | Verify pulse width | | 30 | — | — | μs |
| t_{PWP} | Programming pulse width | | 20 | — | — | ms |

Figure 6. Erase (User Erase or Erase All) Timing Diagram

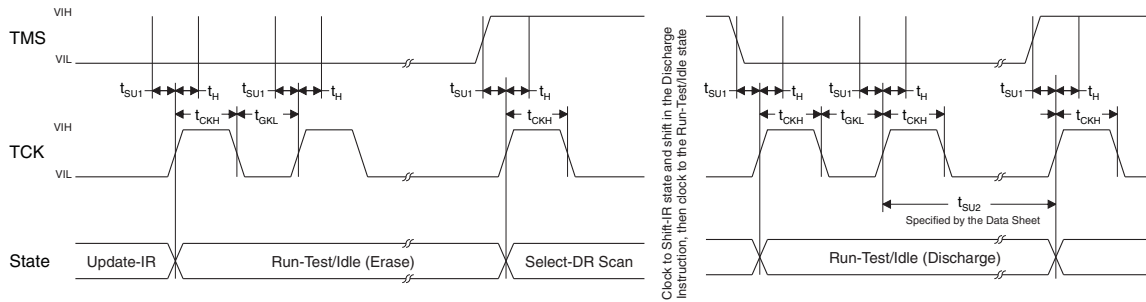

Figure 7. Programming Timing Diagram

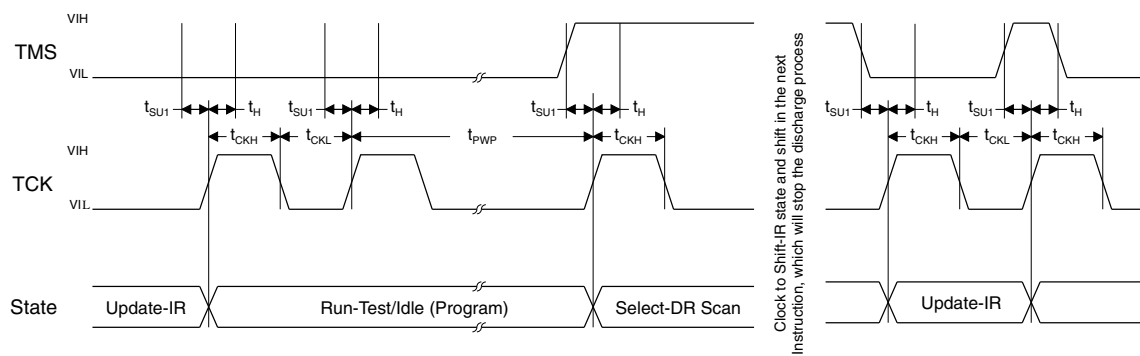

Figure 8. Verify Timing Diagram

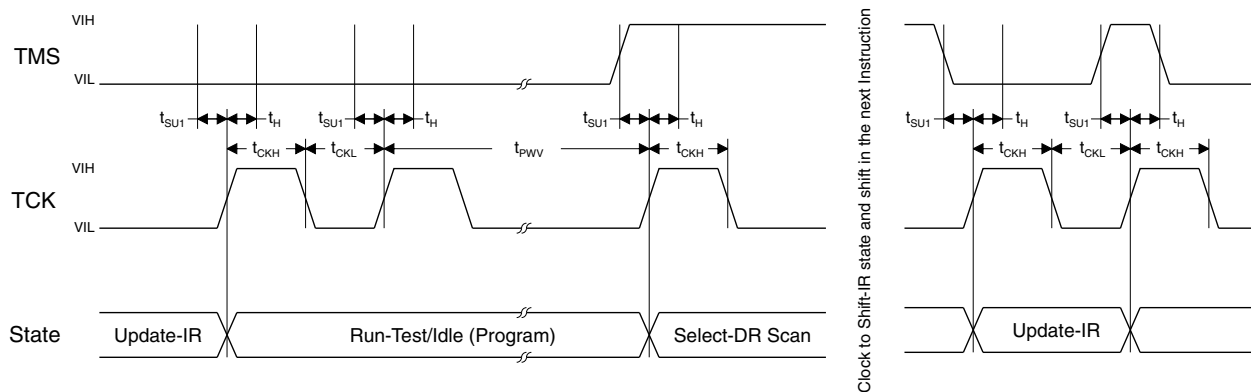
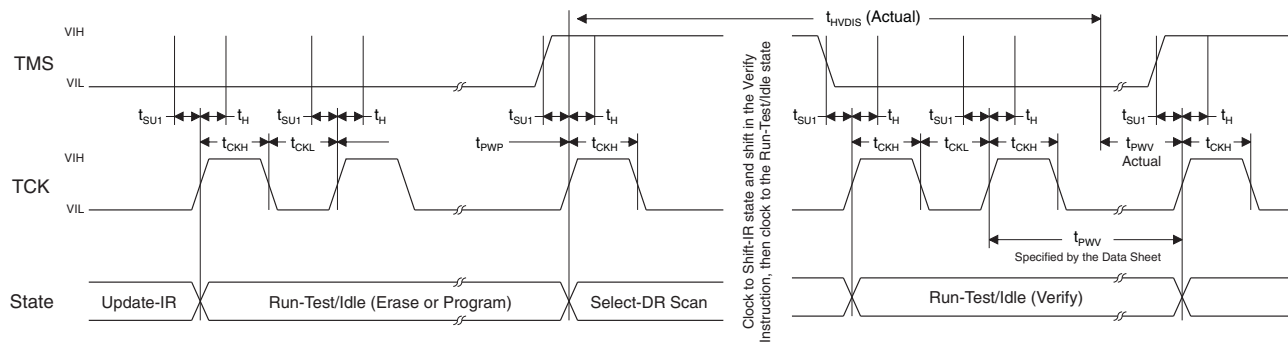

Figure 9. Discharge Timing Diagram



Theory of Operation

Analog Monitor Inputs

The ProcessorPM-POWR605 provides six independently programmable voltage monitor input circuits as shown in Figure 10. One programmable trip-point comparator is connected to each analog monitoring input. Each comparator reference has 192 programmable trip points over the range of 0.669V to 5.793V. Additionally, a 75mV 'zero-detect' threshold is selectable which allows the voltage monitors to determine if a monitored signal has dropped to ground level. This feature is especially useful for determining if a power supply's output has decayed to a substantially inactive condition after it has been switched off.

Figure 10. ProcessorPM-POWR605 Voltage Monitors

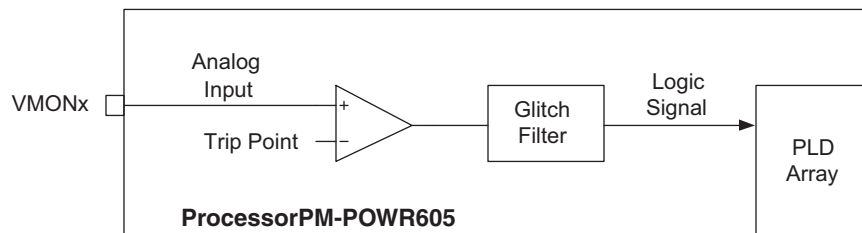

Figure 10 shows the functional block diagram of one of the six voltage monitor inputs - 'x' (where x = 1...6). Each voltage monitor can be divided into two sections: Analog Input, and Filtering.

The voltage input is monitored by a programmable trip-point comparator. Table 1 and Table 2 show all trip points and ranges to which any comparator's threshold can be set.

Each comparator outputs a HIGH signal to the PLD array if the voltage at its positive terminal (VMONx pin) is greater than its programmed trip point setting, otherwise it outputs a LOW signal.

A hysteresis of approximately 1% of the setpoint is provided by the comparators to reduce false triggering as a result of input noise. The hysteresis provided by the voltage monitor is a function of the input divider setting. Table 3 lists the typical hysteresis versus voltage monitor trip-point.

Programmable Over-Voltage and Under-Voltage Thresholds

Figure 11 (a) shows the power supply ramp-up and ramp-down voltage waveforms. Because of hysteresis, the comparator outputs change state at different thresholds depending on the direction of excursion of the monitored power supply.

Figure 11. (a) Power Supply Voltage Ramp-up and Ramp-down Waveform and the Resulting Comparator Output, (b) Corresponding to Upper and Lower Trip Points

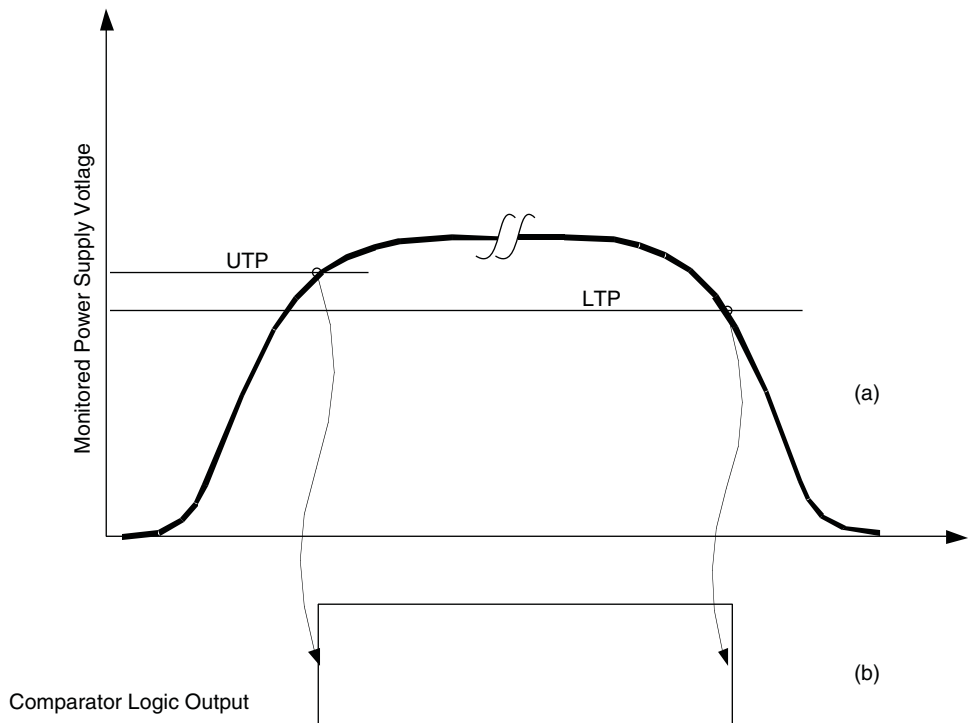

During power supply ramp-up the comparator output changes from logic 0 to 1 when the power supply voltage crosses the upper trip point (UTP). During ramp down the comparator output changes from logic state 1 to 0 when the power supply voltage crosses the lower trip point (LTP). To monitor for over voltage fault conditions, the UTP should be used. To monitor under-voltage fault conditions, the LTP should be used.

Tables 1 and 2 show both the under-voltage and over-voltage trip points, which are automatically selected in software depending on whether the user is monitoring for an over-voltage condition or an under-voltage condition.

Table 1. Trip Point Table Used For Over-Voltage Detection (in Volts)

| REF/ MON | F | E | D | C | B | A | 9 | 8 | 7 | 6 | 5 | 4 |
|-------------|-------|-------|-------|-------|-------|-------|-------|-------|-------|-------|-------|-------|
| 1F | 0.799 | 0.952 | 1.134 | 1.349 | 1.597 | 1.904 | 2.266 | 2.690 | 3.189 | 3.795 | 4.864 | 5.793 |
| 1E | 0.791 | 0.943 | 1.122 | 1.335 | 1.581 | 1.885 | 2.243 | 2.664 | 3.156 | 3.756 | 4.814 | 5.734 |
| 1D | 0.783 | 0.933 | 1.111 | 1.321 | 1.565 | 1.866 | 2.220 | 2.636 | 3.123 | 3.718 | 4.764 | 5.675 |
| 1C | 0.775 | 0.923 | 1.099 | 1.308 | 1.548 | 1.847 | 2.196 | 2.608 | 3.091 | 3.679 | 4.715 | 5.615 |
| 1B | 0.767 | 0.913 | 1.088 | 1.294 | 1.532 | 1.827 | 2.173 | 2.581 | 3.059 | 3.640 | 4.665 | 5.556 |
| 1A | 0.758 | 0.904 | 1.076 | 1.280 | 1.516 | 1.808 | 2.150 | 2.553 | 3.026 | 3.601 | 4.615 | 5.497 |
| 19 | 0.750 | 0.894 | 1.065 | 1.266 | 1.499 | 1.788 | 2.127 | 2.526 | 2.994 | 3.562 | 4.566 | 5.438 |
| 18 | 0.743 | 0.884 | 1.053 | 1.252 | 1.484 | 1.769 | 2.103 | 2.498 | 2.961 | 3.524 | 4.516 | 5.379 |
| 17 | 0.735 | 0.874 | 1.041 | 1.240 | 1.468 | 1.749 | 2.081 | 2.471 | 2.928 | 3.485 | 4.467 | 5.320 |
| 16 | 0.727 | 0.865 | 1.030 | 1.226 | 1.451 | 1.730 | 2.058 | 2.444 | 2.896 | 3.446 | 4.417 | 5.261 |
| 15 | 0.718 | 0.855 | 1.018 | 1.212 | 1.435 | 1.710 | 2.035 | 2.416 | 2.864 | 3.407 | 4.367 | 5.201 |
| 14 | 0.710 | 0.845 | 1.007 | 1.198 | 1.419 | 1.691 | 2.012 | 2.389 | 2.831 | 3.369 | 4.318 | 5.143 |
| 13 | 0.702 | 0.836 | 0.995 | 1.184 | 1.402 | 1.671 | 1.988 | 2.361 | 2.798 | 3.330 | 4.268 | 5.083 |
| 12 | 0.694 | 0.826 | 0.983 | 1.171 | 1.386 | 1.652 | 1.965 | 2.333 | 2.766 | 3.291 | 4.218 | 5.025 |
| 11 | 0.686 | 0.816 | 0.972 | 1.157 | 1.370 | 1.632 | 1.942 | 2.306 | 2.733 | 3.252 | 4.169 | 4.965 |
| 10 | 0.678 | 0.806 | 0.960 | 1.143 | 1.353 | 1.614 | 1.919 | 2.279 | 2.700 | 3.214 | 4.119 | 4.906 |

Table 2. Trip Point Table Used For Under-Voltage Detection (in Volts)

| REF/ MON | F | E | D | C | B | A | 9 | 8 | 7 | 6 | 5 | 4 |
|-------------|-------|-------|-------|-------|-------|-------|-------|-------|-------|-------|-------|-------|
| 1F | 0.791 | 0.943 | 1.122 | 1.335 | 1.581 | 1.885 | 2.243 | 2.664 | 3.156 | 3.756 | 4.814 | 5.734 |
| 1E | 0.783 | 0.933 | 1.111 | 1.321 | 1.565 | 1.866 | 2.220 | 2.636 | 3.123 | 3.718 | 4.764 | 5.675 |
| 1D | 0.775 | 0.923 | 1.099 | 1.308 | 1.548 | 1.847 | 2.196 | 2.608 | 3.091 | 3.679 | 4.715 | 5.615 |
| 1C | 0.767 | 0.913 | 1.088 | 1.294 | 1.532 | 1.827 | 2.173 | 2.581 | 3.059 | 3.640 | 4.665 | 5.556 |
| 1B | 0.758 | 0.904 | 1.076 | 1.280 | 1.516 | 1.808 | 2.150 | 2.553 | 3.026 | 3.601 | 4.615 | 5.497 |
| 1A | 0.750 | 0.894 | 1.065 | 1.266 | 1.499 | 1.788 | 2.127 | 2.526 | 2.994 | 3.562 | 4.566 | 5.438 |
| 19 | 0.743 | 0.884 | 1.053 | 1.252 | 1.484 | 1.769 | 2.103 | 2.498 | 2.961 | 3.524 | 4.516 | 5.379 |
| 18 | 0.735 | 0.874 | 1.041 | 1.240 | 1.468 | 1.749 | 2.081 | 2.471 | 2.928 | 3.485 | 4.467 | 5.320 |
| 17 | 0.727 | 0.865 | 1.030 | 1.226 | 1.451 | 1.730 | 2.058 | 2.444 | 2.896 | 3.446 | 4.417 | 5.261 |
| 16 | 0.718 | 0.855 | 1.018 | 1.212 | 1.435 | 1.710 | 2.035 | 2.416 | 2.864 | 3.407 | 4.367 | 5.201 |
| 15 | 0.710 | 0.845 | 1.007 | 1.198 | 1.419 | 1.691 | 2.012 | 2.389 | 2.831 | 3.369 | 4.318 | 5.143 |
| 14 | 0.702 | 0.836 | 0.995 | 1.184 | 1.402 | 1.671 | 1.988 | 2.361 | 2.798 | 3.330 | 4.268 | 5.083 |
| 13 | 0.694 | 0.826 | 0.983 | 1.171 | 1.386 | 1.652 | 1.965 | 2.333 | 2.766 | 3.291 | 4.218 | 5.025 |
| 12 | 0.686 | 0.816 | 0.972 | 1.157 | 1.370 | 1.632 | 1.942 | 2.306 | 2.733 | 3.252 | 4.169 | 4.965 |
| 11 | 0.678 | 0.806 | 0.960 | 1.143 | 1.353 | 1.614 | 1.919 | 2.279 | 2.700 | 3.214 | 4.119 | 4.906 |
| 10 | 0.669 | 0.797 | 0.949 | 1.129 | 1.337 | 1.594 | 1.895 | 2.252 | 2.669 | 3.175 | 4.069 | 4.847 |

Table 3. Comparator Hysteresis vs. Trip-Point

| Trip-point Range (V) | | Hysteresis (mV) |
|----------------------|------------|-----------------|
| Low Limit | High Limit | |
| 0.669 | 0.799 | 8 |
| 0.797 | 0.952 | 10 |
| 0.949 | 1.134 | 12 |
| 1.129 | 1.349 | 14 |
| 1.337 | 1.597 | 17 |
| 1.594 | 1.904 | 19 |
| 1.895 | 2.266 | 23 |
| 2.252 | 2.690 | 28 |
| 2.669 | 3.189 | 33 |
| 3.175 | 3.795 | 39 |
| 4.069 | 4.864 | 50 |
| 4.847 | 5.793 | 60 |
| 75 mV | | 0 (Disabled) |

The second section in the ProcessorPM-POWR605's input voltage monitor is a digital filter. When enabled, the comparator output will be delayed by a filter time constant of 48 μ s, and is especially useful for reducing the possibility of false triggering from noise that may be present on the voltages being monitored. When the filter is disabled, the comparator output will be delayed by 12 μ s. In both cases, enabled or disabled, the filters also provide synchronization of the input signals to the PLD clock. This synchronous sampling feature effectively eliminates the possibility of race conditions from occurring in any subsequent logic that is implemented in the ProcessorPM-POWR605's internal PLD logic.

PLD Block

Figure 12 shows the ProcessorPM-POWR605 PLD architecture, which is derived from Lattice's ispMACH[®] 4000 CPLD. The PLD architecture allows flexibility in designing various state machines and control functions for power supply management. The AND array has 28 inputs and generates 81 product terms. The product terms are fed into a single logic block made up of 16 macrocells. The output signals of the ProcessorPM-POWR605 device are derived from the PLD as shown in Figure 12.

Figure 12. ProcessorPM-POWR605 PLD Architecture

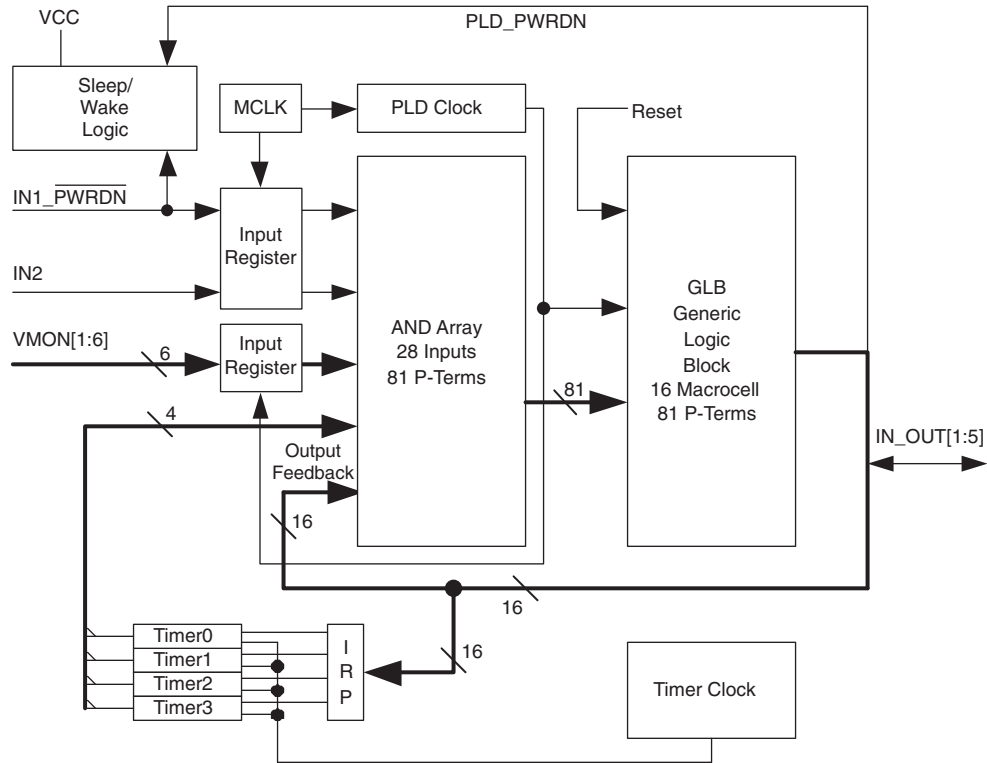

Macrocell Architecture

The macrocell shown in Figure 13 is the heart of the PLD. The basic macrocell has five product terms that feed the OR gate and the flip-flop. The flip-flop in each macrocell is independently configured. It can be programmed to function as a D-Type or T-Type flip-flop. Combinatorial functions are realized by bypassing the flip-flop. The polarity control and XOR gates provide additional flexibility for logic synthesis. The flip-flop's clock is driven from the common PLD clock that is generated by dividing the 8 MHz master clock (MCLK) by 32. The macrocell also supports asynchronous reset and preset functions, derived from either product terms or the power-on reset signal. The resources within the macrocells share routing and contain a product term allocation array. The product term allocation array greatly expands the PLD's ability to implement complex logical functions by allowing logic to be shared between adjacent blocks and distributing the product terms to allow for wider decode functions. All the digital inputs are registered by MCLK and all VMON comparator outputs are registered using the PLD Clock to synchronize them to the PLD logic as shown in Figure 12.

Figure 13. ProcessorPM-POWR605 Macrocell Block Diagram

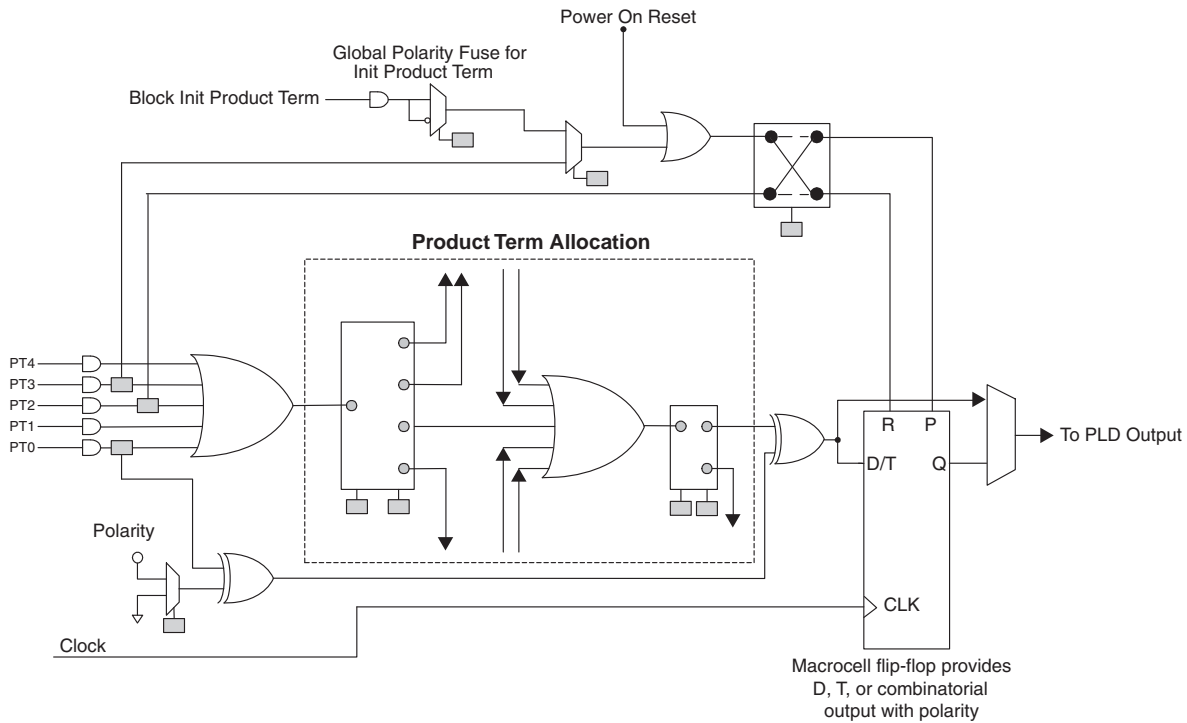

Clock and Timer Functions

Figure 14 shows a block diagram of the ProcessorPM-POWR605's internal clock and timer systems. The master clock operates at a fixed frequency of 8MHz, from which a fixed 250kHz PLD clock is derived.

Figure 14. Clock and Timer System

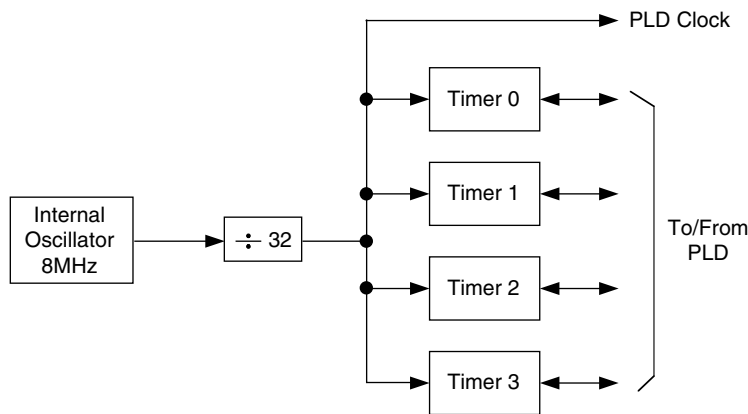

The internal oscillator runs at a fixed frequency of 8 MHz. This signal is used as a source for the PLD and timer clocks. It is also used for clocking the comparator outputs and clocking the digital filters in the voltage monitor circuits.

A divide-by-32 prescaler divides the internal 8MHz oscillator down to 250kHz for the PLD clock and for the programmable timers. Each of the four timers provides independent timeout intervals ranging from 32μs to 1.96 seconds in 128 steps.

Digital Inputs and Optional Device Power Down

The ProcessorPM-POWR605 has two dedicated digital input pins which are registered by MCLK as shown in Figure 12, then connected to the input AND array of the PLD (IN[1:2]). The pins are standard CMOS inputs and are referenced to VCC.

The optional power-down mode is a programmable feature controlled via the IN1_PWRDN pin. It is used to power-down the ProcessorPM-POWR605 and power it up again as desired. When in power-down mode, the ProcessorPM-POWR605 draws a minimal amount of supply current (less than 10µA max). The device is brought out of power-down mode by applying a logic high signal on the level sensitive IN1_PWRDN pin.

When it exits power-down mode, the ProcessorPM-POWR605 is internally reset to its initial power-on state before resuming normal operation. The logic and limited memory needed to “wake up” on cue are all that remain on during power-down mode. Other functions and capabilities such as voltage monitoring and PLD logic states are all lost when the ProcessorPM-POWR605 is in power-down mode. Open drain outputs go into Hi-Z mode and all digital inputs, except IN1_PWRDN, stop responding to logic input signals.

There are two E²CMOS bits associated with the ProcessorPM-POWR605 power-down function. Configuring these bits for specific power-down functionality is achieved using PAC-Designer, a software design tool for Lattice programmable mixed signal devices. Table 4 is a truth table detailing the operation of the ProcessorPM-POWR605 power-down logical control function.

Table 4. PWRDN Truth Table

| IN1_PWRDN Input Pin | PLD_PWRDN Internal Signal | PWRDN Enable Bit | PWRDN Source Bit | Power Mode |
|---------------------|---------------------------|------------------|---------------------------|------------|
| X | X | Clear | X | Normal |
| 1 | X | Set | X | Normal |
| 0 | X | Set | IN1_PWRDN Pin | Power-down |
| 0 | 0 | Set | Internal Signal PLD_PWRDN | Power-down |

Note: When in power-down mode, the ProcessorPM-POWR605 will not respond to logic inputs (except to the IN1_PWRDN pin) and all outputs will be high impedance.

To use the ProcessorPM-POWR605’s power-down function, the E²CMOS PWRDN enable bit must be set during initial device design configuration. Power-down is disabled otherwise (the initial default).

When power is first applied to ProcessorPM-POWR605, the device checks to see if a power-down condition exists, and then if it is already present will proceed immediately to the power-down state. During the brief period that the device is on, it will consume full power but it will proceed directly to power-down mode without executing any state machine instructions, etc. This time to initially detect the power-down command and then shut down is given in the power-down specifications section of the data sheet.

In addition to the IN1_PWRDN pin, Table 4 shows how an alternate signal from the PLD called PLD_PWRDN can be used to initiate power-down (not the default). This can be useful when power-down is the last step in a series of ProcessorPM-POWR605 PLD controlled states, such as turning off supplies in sequence or acknowledging processor signals, etc.

Note: The only way to exit power-down mode, regardless of how it is initiated, is with the IN1_PWRDN pin. Applying a logic high to IN1_PWRDN will always return the ProcessorPM-POWR605 to normal operation. Finally, whenever the ProcessorPM-POWR605 is in power-down mode, VCCJ is internally pulled to GND to turn off the JTAG I/O pins. It is important, therefore, that the VCCJ pin be open when power-down mode is initiated. If connected to a power supply during power-down mode, VCCJ will draw approximately 2.2mA.

Dual Purpose Digital I/O Pins

The ProcessorPM-POWR605 provides five possible digital outputs, IN_OUT[1:5]. Any number of these pins can be configured to act as open drain outputs, providing a high degree of flexibility when interfacing to logic signals,

LEDs, opto-couplers, and power supply control inputs. The digital I/O pins can also be programmed to be true digital inputs.

It should be noted the IN_OUT[1:5] pins are not true bidirectional pins and individually they can only act as an input or as an output, but not both at the same time. A simplified diagram of how this is accomplished is shown in Figure 15. There is a user configurable E²CMOS bit for each of the IN_OUT[1:5] pins that determines whether the pin is a dedicated input or open drain output.

Figure 15. Programmable Digital Input/Output Pins (IN_OUT)

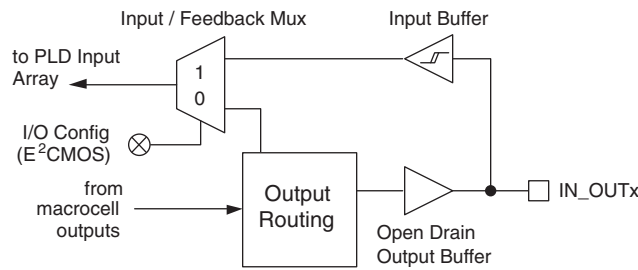

The architecture takes advantage of routing that normally feeds all PLD macrocell outputs back into the input AND array. Output pins are realized when some number of macrocell outputs are selected from the PLD to become digital open drain outputs. When programmed to be outputs, IN_OUTx pins are configured exactly this way. When programmed to be digital input pins, the open drain buffer is permanently turned off (set to Hi-Z) and the input from IN_OUTx pin goes to the input array instead of the macrocell's output. The macrocell output is still available and can be connected to a different output pin if desired.

When IN_OUTx pins are configured as digital input pins, the signal is registered by MCLK prior to going to the input AND array, the same as the IN1 and IN2 digital inputs.

Software-Based Design Environment

Designers can configure the ProcessorPM-POWR605 using PAC-Designer, an easy to use, Microsoft Windows compatible program. Circuit designs are entered graphically and then verified, all within the PAC-Designer environment. Full device programming is supported using PC parallel port I/O operations and a download cable connected to the serial programming interface pins of the ProcessorPM-POWR605. A library of configurations is included with basic solutions and examples of advanced circuit techniques are available on the Lattice web site for downloading. In addition, comprehensive on-line and printed documentation is provided that covers all aspects of PAC-Designer operation. The PAC-Designer schematic window, shown in Figure 16, provides access to all configurable ProcessorPM-POWR605 elements via its graphical user interface. All analog input and output pins are represented. Static or non-configurable pins such as power, ground, and the serial digital interface are omitted for clarity. Any element in the schematic window can be accessed via mouse operations as well as menu commands. When completed, configurations can be saved, simulated, and downloaded to devices.

Figure 16. PAC-Designer ProcessorPM-POWR605 Design Entry Screen

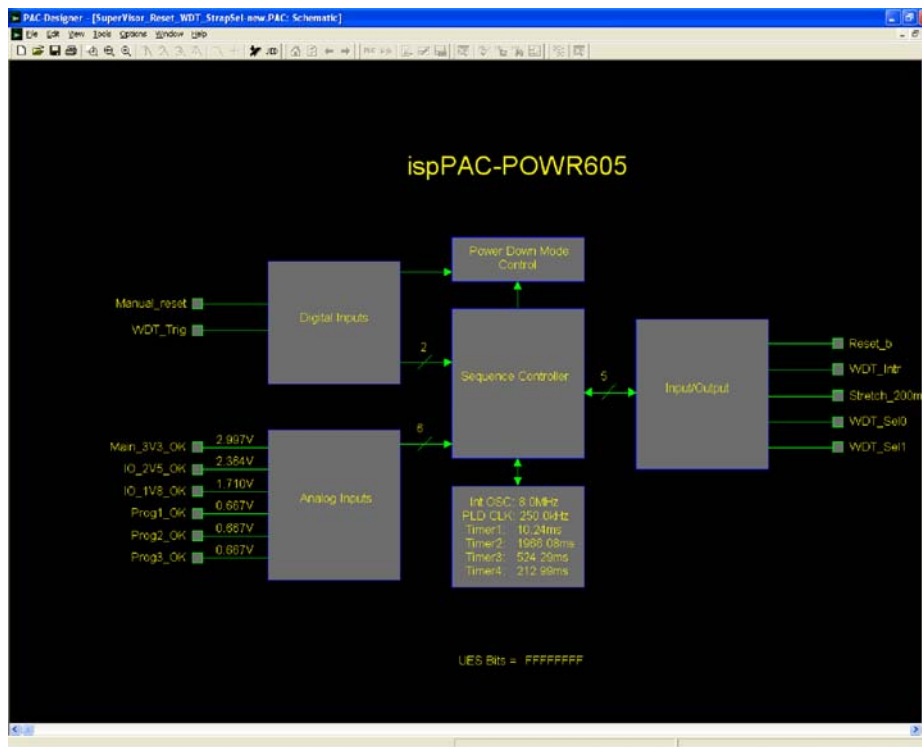

In-System Programming

The ProcessorPM-POWR605 is an in-system programmable device. This is accomplished by integrating all E² configuration memory on-chip. Programming is performed through a 4-wire, IEEE 1149.1 compliant serial JTAG interface at normal logic levels. Once a device is programmed, all configuration information is stored on-chip, in non-volatile E²CMOS memory cells. The specifics of the IEEE 1149.1 serial interface and all ProcessorPM-POWR605 instructions are described in the JTAG interface section of this data sheet.

User Electronic Signature

A user electronic signature (UES) feature is included in the E²CMOS memory of the ProcessorPM-POWR605. This consists of 32 bits that can be configured by the user to store unique data such as ID codes, revision numbers or inventory control data. The specifics of this feature are discussed in the IEEE 1149.1 serial interface section of this data sheet.

Electronic Security

An electronic security “fuse” (ESF) bit is provided in every ProcessorPM-POWR605 device to prevent unauthorized readout of the E²CMOS configuration bit patterns. Once programmed, this cell prevents further access to the functional user bits in the device. This cell can only be erased by reprogramming the device, so the original configuration cannot be examined once programmed. Usage of this feature is optional. The specifics of this feature are discussed in the IEEE 1149.1 serial interface section of this data sheet.

Production Programming Support

Once a final configuration is determined, an ASCII format JEDEC file can be created using the PAC-Designer software. Devices can then be ordered through the usual supply channels with the user’s specific configuration already preloaded into the devices. By virtue of its standard interface, compatibility is maintained with existing production programming equipment, giving customers a wide degree of freedom and flexibility in production planning.

Initial Factory Configuration

ProcessorPM devices are shipped preconfigured with a 6-supply reset generator and a programmable watchdog timer application. This section describes the implemented functions in detail.

Figure 17 shows the functional block diagram implemented in the factory-configured ProcessorPM device.

Figure 17. Initial Factory Configuration Functional Block Diagram

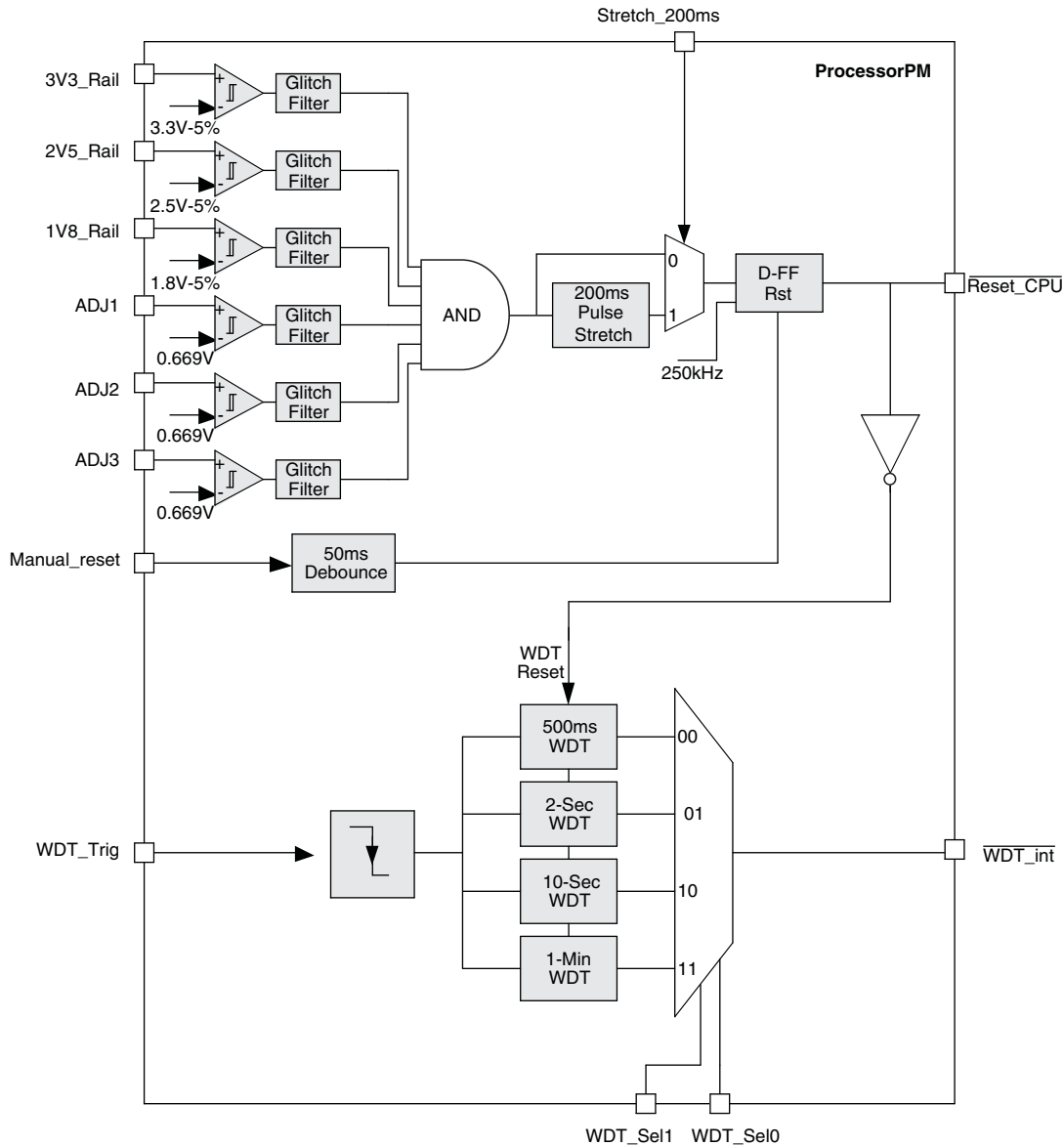

The output of the 6-supply voltage monitor block will switch to logic 1 when all six supply-rail voltages are above their respective threshold settings. Each of the voltage monitoring inputs is filtered with a 48 microsecond glitch filter. All six glitch filter outputs are connected to a 6-input AND gate. The AND gate output is connected to a 200ms pulse stretch block. The user may or may not bypass the 200ms pulse stretch block via multiplexer selection. When the Stretch_200ms signal is at logic 0, the output of the 6-input AND gate is routed directly to the D-FF. When the Stretch_200ms signal is at Logic 1, the output of the 200ms Pulse Stretch block is routed to the D-FF. The D-FF is clocked by an internally-generated 250 kHz signal and is reset when the manual reset input is activated. The Reset_CPU signal is active low, that is, logic 0, when any supply is less than its threshold or when the manual reset

input is active. $\overline{\text{Reset_CPU}}$ is logic 1 when all supplies are above their respective thresholds and the manual reset input is inactive. When $\overline{\text{Reset_CPU}}$ is active the watchdog timer is held in the reset state.

During the operation, one can directly reset the output using the Manual_reset pin. The Manual_reset signal is an active low input. The 50ms de-bounce circuit block filters glitches less than 50ms and the filtered signal is used to reset the D-FF. Minimum pulse width of the manual reset input is 50ms.

The ProcessorPM design provides a watchdog timer with 4 pin-selectable timer delay settings. The watchdog timers are triggered by the falling edge of the WDT_Trigger signal. Minimum pulse width of the WDT_Trigger signal is 10 microseconds. The WDT_Sel1 and WDT_Sel0 signals are used to select the Watchdog timer delay. Table 5 shows the watchdog timer delay setting corresponding to WDT_Sel1 and WDT_Sel0 inputs.

Table 5. Programmable Watchdog Timer Delay Selection

| WTD_Sel1 | WTD_Sel0 | Watchdog Timer Delay (Typ.) |
|----------|----------|-----------------------------|
| 0 | 0 | 500 ms |
| 0 | 1 | 2 sec. |
| 1 | 0 | 10 sec. |
| 1 | 1 | 1 min. |

When the delay between successive WDT_Trigger falling edge signals exceeds the watchdog timer delay setting, a 6-microsecond-wide low-going pulse is generated on the $\overline{\text{WDT_int}}$ pin. After generating the output pulse, the watchdog timer is restarted. It continues to generate 6-microsecond pulses regularly at watchdog delay set intervals until a falling edge of WDT_Trigger signal is received. Watchdog timers start after the $\overline{\text{Reset_CPU}}$ signal is deactivated.

The following timing waveform shows $\overline{\text{WDT_int}}$ signal after the watchdog timer expiry. Note the minimum watchdog Trigger pulse width is 10 microseconds. The watchdog timer gets retriggered only by the falling edge of the WDT_Trigger signal.

Figure 18. Watchdog Timer Interrupt Generation Timing

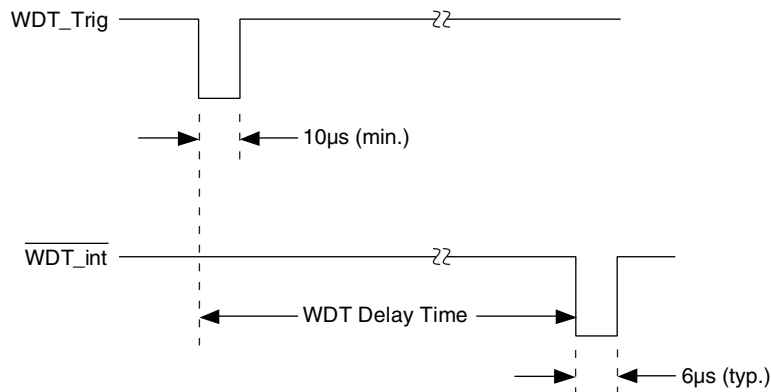

The watchdog timer delay can be dynamically changed before the current watchdog timer elapse time is exceeded in order to provide for a longer startup delay, for example. However, any changes made to WDT_Sel1 and WDT_Sel0 must be done within 400ms of either the rising edge of $\overline{\text{Reset_CPU}}$ or the falling edge of WDT_Trigger. For example, WDT_Sel1 and WDT_Sel0 might initially be set to 0x10 for a power-up delay of 10 seconds and then after the system is up and running WDT_Sel1 and WDT_Sel0 might be modified to 0x00 to enable a shorter watchdog delay of 500ms. The change in the WDT_Sel1 and WDT_Sel0 bits must be made within 400ms of a WDT_Trigger pulse to alter the current WDT delay time. If the change occurs after the 400ms window, the current WDT delay time is not guaranteed.

Programmable Reset Generator

The integrated reset generator activates (Active low) the $\overline{\text{Reset_CPU}}$ signal (Figure 2) when any of the six supplies are less than their fault level. When all supplies are stable and the pulse stretch function is enabled the $\overline{\text{Reset_CPU}}$ signal will be deactivated after 200 ms.

Voltage threshold setting:

- VMON1 to VMON3 thresholds are set to 3.3V - 5%, 2.5V - 5% and 1.8V - 5% respectively
- VMON4 to VMON6 thresholds are set at 0.669V. These VMON inputs can be used to monitor supply rails from 0.669V to 24V or higher using external resistor-based potential dividers. The resistor values are calculated using the formula shown in Figure 19.
- When monitoring fewer than six supplies, all unused VMON inputs should be connected to 3.3V rail.

Figure 19. Setting Fault Threshold Using External Resistors for VMON4, VMON5 and VMON6

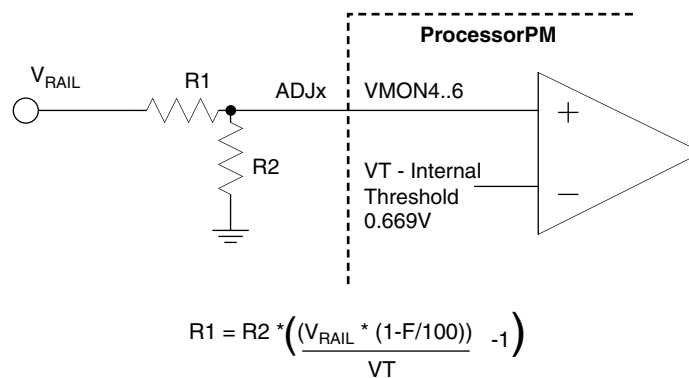

Note: This equation assumes that $R2 \leq 3K \text{ Ohm}$

V_{RAIL} – Monitored Supply Rail Voltage
 F – Supply Fault Tolerance level in %
 VT – VMON Threshold setting = 0.669V

Programmable Reset Pulse Stretching

Some reset generator functions require that the reset pulse be held active for an extended period of time after the supplies are stabilized. One can introduce a 200 ms pulse stretch by connecting the Stretch_200ms pin to 3.3V. If the Stretch_200ms pin is grounded the reset pulse stretch function will be disabled.

Manual_reset Input

When the Manual_reset input is pulled low, the $\overline{\text{Reset_CPU}}$ gets activated immediately. When the reset input is released, the reset output also gets released. The Manual_reset input is debounced with a 50 ms timer.

Figure 20. $\overline{\text{Reset_CPU}}$ Signal Responding to Manual_reset

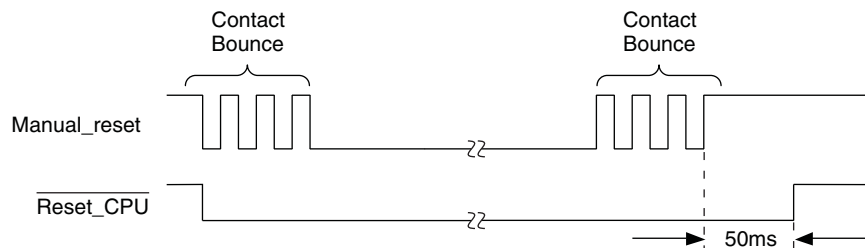

ProcessorPM devices are factory preconfigured to integrate a programmable 6-supply reset generator (configured through pin strapping) and a programmable watchdog timer. See Figure 21.

Figure 21. Reset Generator Programmable Pulse Stretch and Watchdog Timer Programmable Up to One Minute (Initial Factory Configuration)¹

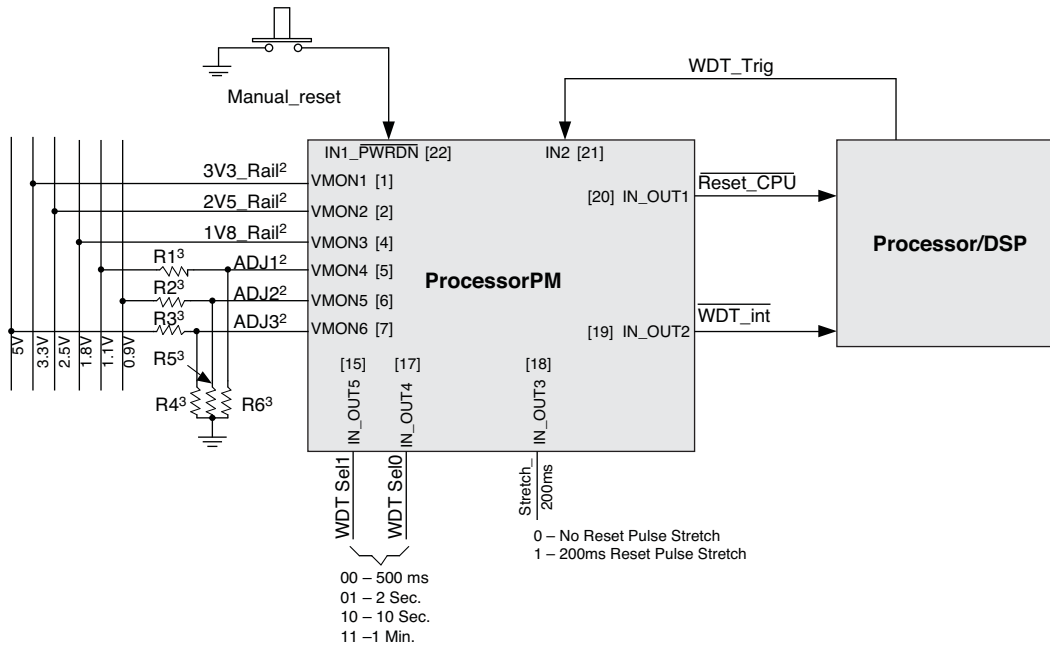

1. Pin numbers shown in brackets.
2. Connect unused VMONs to 3.3V rail.
3. R1..R6 required to externally adjust fault threshold when using factory default configuration. For supply rails <5.7V, R1..R6 are not required if fault thresholds are programmed into the ProcessorPM.

IEEE Standard 1149.1 Interface (JTAG)

Serial Port Programming Interface Communication with the ProcessorPM-POWR605 is facilitated via an IEEE 1149.1 test access port (TAP). It is used by the ProcessorPM-POWR605 as a serial programming interface. A brief description of the ProcessorPM-POWR605 JTAG interface follows. For complete details of the reference specification, refer to the publication, Standard Test Access Port and Boundary-Scan Architecture, IEEE Std 1149.1-1990 (which now includes IEEE Std 1149.1a-1993).

Overview

An IEEE 1149.1 test access port (TAP) provides the control interface for serially accessing the digital I/O of the ProcessorPM-POWR605. The TAP controller is a state machine driven with mode and clock inputs. Given in the correct sequence, instructions are shifted into an instruction register, which then determines subsequent data input, data output, and related operations. Device programming is performed by addressing the configuration register, shifting data in, and then executing a program configuration instruction, after which the data is transferred to internal E²CMOS cells. It is these non-volatile cells that store the configuration of the ProcessorPM-POWR605. A set of instructions are defined that access all data registers and perform other internal control operations. For compatibility between compliant devices, two data registers are mandated by the IEEE 1149.1 specification. Others are functionally specified, but inclusion is strictly optional. Finally, there are provisions for optional data registers defined by the manufacturer. The two required registers are the bypass and boundary-scan registers. Figure 22 shows how the instruction and various data registers are organized in an ProcessorPM-POWR605.

Figure 22. ProcessorPM-POWR605 TAP Registers

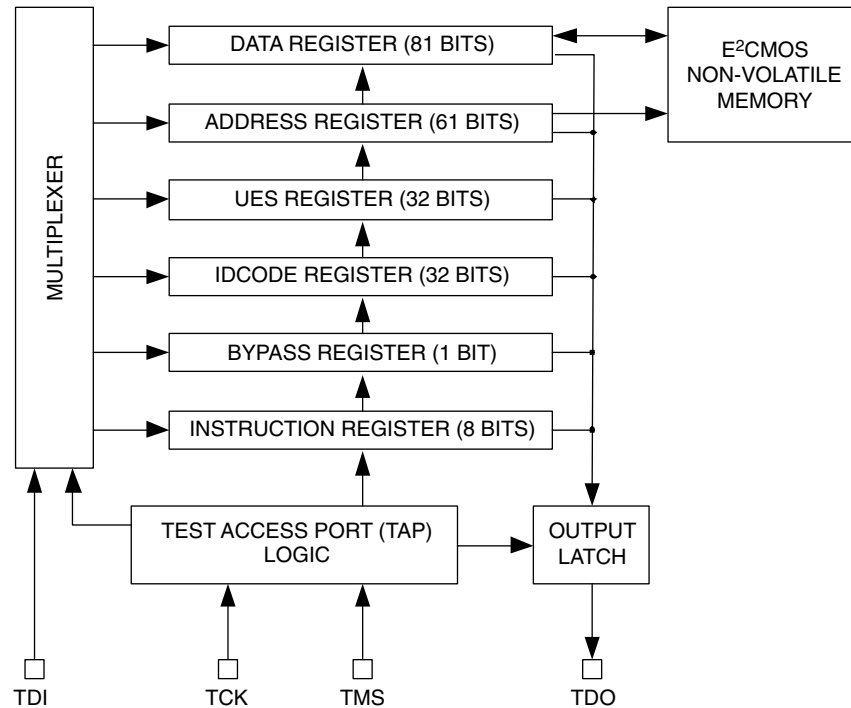

TAP Controller Specifics

The TAP is controlled by the Test Clock (TCK) and Test Mode Select (TMS) inputs. These inputs determine whether an Instruction Register or Data Register operation is performed. Driven by the TCK input, the TAP consists of a small 16-state controller design. In a given state, the controller responds according to the level on the TMS input as shown in Figure 23. Test Data In (TDI) and TMS are latched on the rising edge of TCK, with Test Data Out (TDO) becoming valid on the falling edge of TCK. There are six steady states within the controller: Test-Logic-Reset, Run-Test/Idle, Shift-Data-Register, Pause-Data-Register, Shift-Instruction-Register and Pause-Instruction-Register. But there is only one steady state for the condition when TMS is set high: the Test-Logic-Reset state. This allows a reset of the test logic within five TCKs or less by keeping the TMS input high. Test-Logic-Reset is the power-on default state.

Figure 23. TAP States

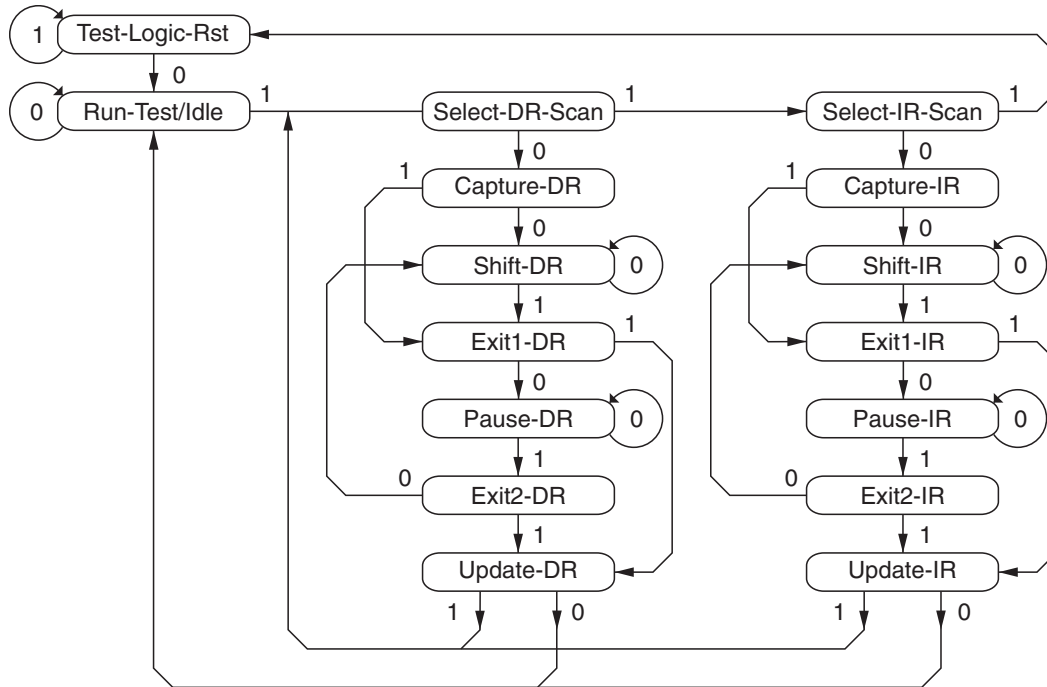

Note: The value shown adjacent to each state transition in this figure represents the signal present at TMS at the time of a rising edge at TCK.

When the correct logic sequence is applied to the TMS and TCK inputs, the TAP will exit the Test-Logic-Reset state and move to the desired state. The next state after Test-Logic-Reset is Run-Test/Idle. Until a data or instruction shift is performed, no action will occur in Run-Test/Idle (steady state = idle). After Run-Test/Idle, either a data or instruction shift is performed. The states of the Data and Instruction Register blocks are identical to each other differing only in their entry points. When either block is entered, the first action is a capture operation. For the Data Registers, the Capture-DR state is very simple: it captures (parallel loads) data onto the selected serial data path (previously chosen with the appropriate instruction). For the Instruction Register, the Capture-IR state will always load the IDCODE instruction. It will always enable the ID Register for readout if no other instruction is loaded prior to a Shift-DR operation. This, in conjunction with mandated bit codes, allows a “blind” interrogation of any device in a compliant IEEE 1149.1 serial chain. From the Capture state, the TAP transitions to either the Shift or Exit1 state. Normally the Shift state follows the Capture state so that test data or status information can be shifted out or new data shifted in. Following the Shift state, the TAP either returns to the Run-Test/Idle state via the Exit1 and Update states or enters the Pause state via Exit1. The Pause state is used to temporarily suspend the shifting of data through either the Data or Instruction Register while an external operation is performed. From the Pause state, shifting can resume by reentering the Shift state via the Exit2 state or be terminated by entering the Run-Test/Idle state via the Exit2 and Update states. If the proper instruction is shifted in during a Shift-IR operation, the next entry into Run-Test/Idle initiates the test mode (steady state = test). This is when the device is actually programmed, erased or verified. All other instructions are executed in the Update state.

Test Instructions

Like data registers, the IEEE 1149.1 standard also mandates the inclusion of certain instructions. It outlines the function of three required and six optional instructions. Any additional instructions are left exclusively for the manufacturer to determine. The instruction word length is not mandated other than to be a minimum of two bits, with only the BYPASS and EXTEST instruction code patterns being specifically called out (all ones and all zeroes respectively). The ProcessorPM-POWR605 contains the required minimum instruction set as well as one from the optional instruction set. In addition, there are several proprietary instructions that allow the device to be configured and verified. Table 6 lists the instructions supported by the ProcessorPM-POWR605 JTAG Test Access Port (TAP)

controller:

Table 6. ProcessorPM-POWR605 TAP Instruction Table

| Instruction | Command Code | Comments |
|-----------------------------|--------------|---|
| BULK_ERASE | 0000 0011 | Bulk erase device |
| BYPASS | 1111 1111 | Bypass - connect TDO to TDI |
| DISCHARGE | 0001 0100 | Fast VPP discharge |
| ERASE_DONE_BIT | 0010 0100 | Erases Done bit only |
| EXTEST | 0000 0000 | Bypass - connect TDO to TDI |
| IDCODE | 0001 0110 | Read contents of manufacturer ID code (32 bits) |
| OUTPUTS_HIGHZ | 0001 1000 | Force all outputs to High-Z state |
| SAMPLE/PRELOAD | 00011100 | Sample/Preload. Default to bypass. |
| PROGRAM_DISABLE | 0001 1110 | Disable program mode |
| PROGRAM_DONE_BIT | 0010 1111 | Programs the Done bit |
| PROGRAM_ENABLE | 0001 0101 | Enable program mode |
| PROGRAM_SECURITY | 0000 1001 | Program security fuse |
| RESET | 0010 0010 | Resets device |
| PLD_ADDRESS_SHIFT | 0000 0001 | PLD_Address register (61 bits) |
| PLD_DATA_SHIFT | 0000 0010 | PLD_Data register (81 bits) |
| PLD_INIT_ADDR_FOR_PROG_INCR | 0010 0001 | Initialize the address register for auto increment |
| PLD_PROG_INCR | 0010 0111 | Program column register to E ² and auto increment address register |
| PLD_PROGRAM | 0000 0111 | Program PLD data register to E ² |
| PLD_VERIFY | 0000 1010 | Verifies PLD column data |
| PLD_VERIFY_INCR | 0010 1010 | Load column register from E ² and auto increment address register |
| UES_PROGRAM | 0001 1010 | Program UES bits into E ² |
| UES_READ | 0001 0111 | Read contents of UES register from E ² (32 bits) |

BYPASS is one of the three required instructions. It selects the Bypass Register to be connected between TDI and TDO and allows serial data to be transferred through the device without affecting the operation of the ProcessorPM-POWR605. The IEEE 1149.1 standard defines the bit code of this instruction to be all ones (11111111).

The required **SAMPLE/PRELOAD** instruction dictates the Boundary-Scan Register be connected between TDI and TDO. The ProcessorPM-POWR605 has no boundary scan register, so for compatibility it defaults to the BYPASS mode whenever this instruction is received. The bit code for this instruction is defined by Lattice as shown in Table 6.

The **EXTEST** (external test) instruction is required and would normally place the device into an external boundary test mode while also enabling the boundary scan register to be connected between TDI and TDO. Again, since the ProcessorPM-POWR605 has no boundary scan logic, the device is put in the BYPASS mode to ensure specification compatibility. The bit code of this instruction is defined by the 1149.1 standard to be all zeros (00000000).

The optional **IDCODE** (identification code) instruction is incorporated in the ProcessorPM-POWR605 and leaves it in its functional mode when executed. It selects the Device Identification Register to be connected between TDI and TDO. The Identification Register is a 32-bit shift register containing information regarding the IC manufacturer, device type and version code (Figure 24). Access to the Identification Register is immediately available, via a TAP data scan operation, after power-up of the device, or by issuing a Test-Logic-Reset instruction. The bit code for this instruction is defined by Lattice as shown in Table 6.

Figure 24. ProcessorPM-POWR605 ID Code

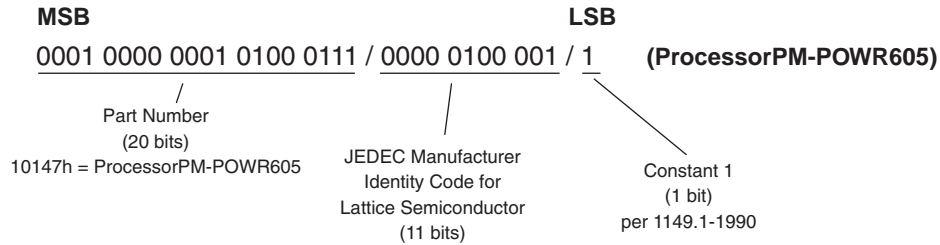

ProcessorPM-POWR605 Specific Instructions

There are 25 unique instructions specified by Lattice for the ProcessorPM-POWR605. These instructions are primarily used to interface to the various user registers and the E²CMOS non-volatile memory. Additional instructions are used to control or monitor other features of the device. A brief description of each unique instruction is provided in detail below, and the bit codes are found in Table 6.

PLD_ADDRESS_SHIFT – This instruction is used to set the address of the PLD AND/ARCH arrays for subsequent program or read operations. This instruction also forces the outputs into the OUTPUTS_HIGHZ.

PLD_DATA_SHIFT – This instruction is used to shift PLD data into the register prior to programming or reading. This instruction also forces the outputs into the OUTPUTS_HIGHZ.

PLD_INIT_ADDR_FOR_PROG_INCR – This instruction prepares the PLD address register for subsequent PLD_PROG_INCR or PLD_VERIFY_INCR instructions.

PLD_PROG_INCR – This instruction programs the PLD data register for the current address and increments the address register for the next set of data.

PLD_PROGRAM – This instruction programs the selected PLD AND/ARCH array column. The specific column is preselected by using PLD_ADDRESS_SHIFT instruction. The programming occurs at the second rising edge of the TCK in Run-Test-Idle JTAG state. The device must already be in programming mode (PROGRAM_ENABLE instruction). This instruction also forces the outputs into the OUTPUTS_HIGHZ.

PROGRAM_SECURITY – This instruction is used to program the electronic security fuse (ESF) bit. Programming the ESF bit protects proprietary designs from being read out. The programming occurs at the second rising edge of the TCK in Run-Test-Idle JTAG state. The device must already be in programming mode (PROGRAM_ENABLE instruction). This instruction also forces the outputs into the OUTPUTS_HIGHZ.

PLD_VERIFY – This instruction is used to read the content of the selected PLD AND/ARCH array column. This specific column is preselected by using PLD_ADDRESS_SHIFT instruction. This instruction also forces the outputs into the OUTPUTS_HIGHZ.

DISCHARGE – This instruction is used to discharge the internal programming supply voltage after an erase or programming cycle and prepares ProcessorPM-POWR605 for a read cycle. This instruction also forces the outputs into the OUTPUTS_HIGHZ.

BULK_ERASE – This instruction will bulk erase all E²CMOS bits (CFG, PLD, UES, and ESF) in the ProcessorPM-POWR605. The device must already be in programming mode (PROGRAM_ENABLE instruction). This instruction also forces the outputs into the OUTPUTS_HIGHZ.

OUTPUTS_HIGHZ – This instruction turns off all of the open-drain output transistors. This instruction is effective after Update-Instruction-Register JTAG state.

PROGRAM_ENABLE – This instruction enables the programming mode of the ProcessorPM-POWR605. This instruction also forces the outputs into the OUTPUTS_HIGHZ.

IDCODE – This instruction connects the output of the Identification Code Data Shift (IDCODE) Register to TDO (Figure 25), to support reading out the identification code.

Figure 25. IDCODE Register

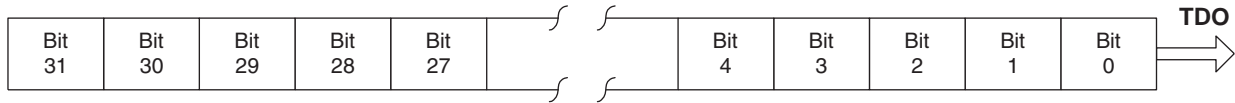

PROGRAM_DISABLE – This instruction disables the programming mode of the ProcessorPM-POWR605. The Test-Logic-Reset JTAG state can also be used to cancel the programming mode of the ProcessorPM-POWR605.

UES_READ – This instruction both reads the E²CMOS bits into the UES register and places the UES register between the TDI and TDO pins (as shown in Figure 22), to support programming or reading of the user electronic signature bits.

Figure 26. UES Register

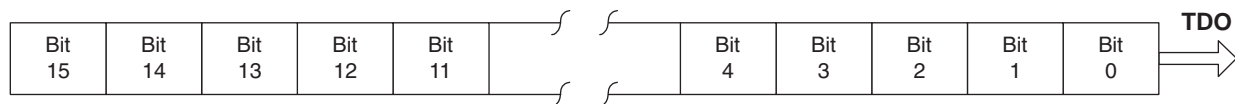

UES_PROGRAM – This instruction will program the content of the UES Register into the UES E²CMOS memory. The device must already be in programming mode (PROGRAM_ENABLE instruction). This instruction also forces the outputs into the OUTPUTS_HIGHZ.

ERASE_DONE_BIT – This instruction clears the Done bit, which prevents the ProcessorPM-POWR605 sequence from starting.

PROGRAM_DONE_BIT – This instruction sets the Done bit, which enables the ProcessorPM-POWR605 sequence to start.

RESET – This instruction resets the PLD sequence and output macrocells. The condition of the ProcessorPM-POWR605 is the same as initial turn-on after POR is completed.

PLD_VERIFY_INCR – This instruction reads out the PLD data register for the current address and increments the address register for the next read.

Notes:

In all of the descriptions above, OUTPUTS_HIGHZ refers to the instruction and the state of the digital I/O pins in output mode in which all are tri-stated.

Before any of the above programming instructions are executed, the respective E²CMOS bits need to be erased using the corresponding erase instruction.

Package Diagram

24-Pin QFNS (Dimensions in Millimeters)

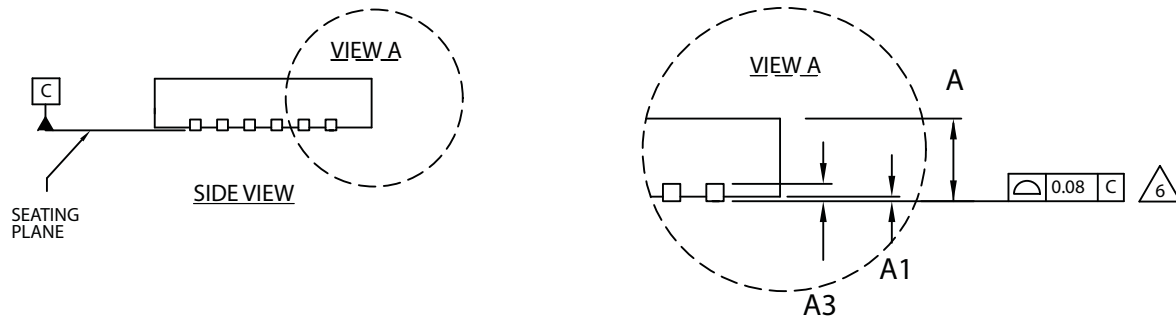
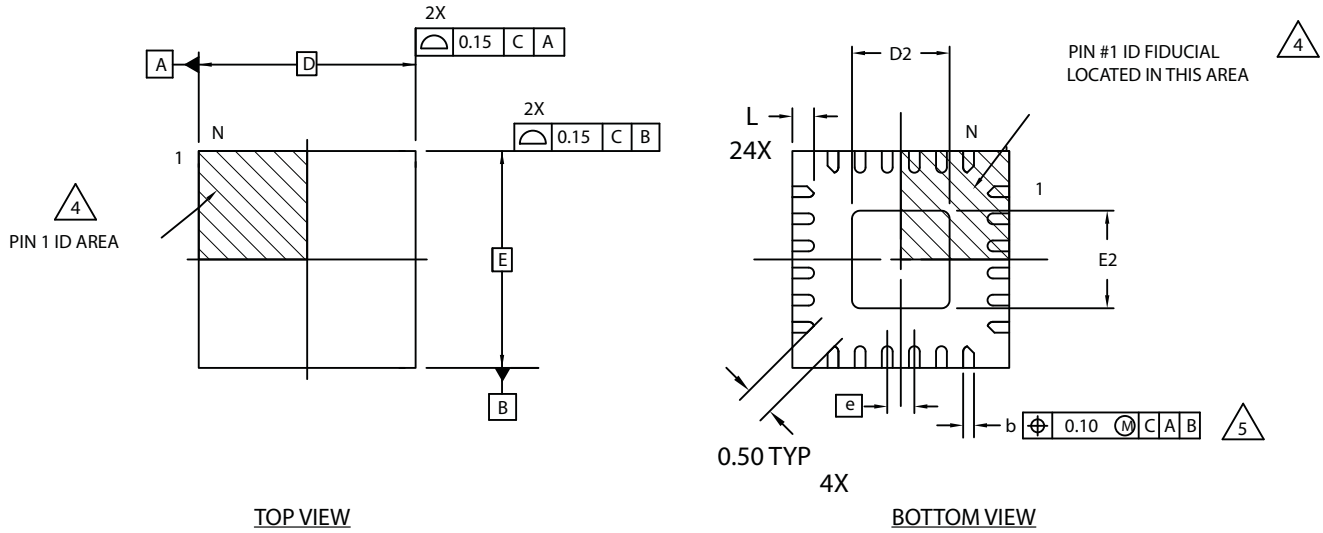

NOTES: UNLESS OTHERWISE SPECIFIED

1. DIMENSIONS AND TOLERANCES PER ANSI Y14.5M.
2. ALL DIMENSIONS ARE IN MILLIMETERS.
3. DRAWING CONFORMS TO JEDEC MO-220, VARIATION VGGD-9.

 EXACT SHAPE AND SIZE OF THIS FEATURE IS OPTIONAL.

 DIMENSION b APPLIES TO PLATED TERMINAL AND IS MEASURED BETWEEN 0.15 AND 0.30 mm FROM TERMINAL TIP.

 APPLIES TO EXPOSED PORTION OF TERMINALS.

| SYMBOL | MIN. | NOM. | MAX. |
|--------|----------|------|------|
| A | 0.80 | 0.90 | 1.00 |
| A1 | 0.00 | 0.02 | 0.05 |
| A3 | 0.2 REF | | |
| D | 4.0 BSC | | |
| D2 | 1.05 | - | 2.45 |
| E | 4.0 BSC | | |
| E2 | 1.05 | - | 2.45 |
| b | 0.18 | 0.25 | 0.30 |
| e | 0.50 BSC | | |
| L | 0.45 | 0.50 | 0.55 |

Part Number Description

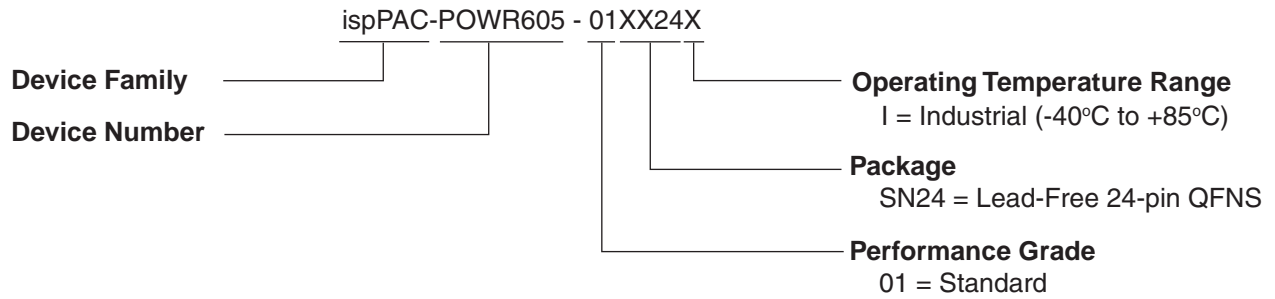

ProcessorPM-POWR605 Ordering Information

Lead-Free Packaging

Industrial

| Part Number | Package | Pins |
|------------------------|----------------|------|
| ispPAC-POWR605-01SN24I | Lead-Free QFNS | 24 |

Package Options

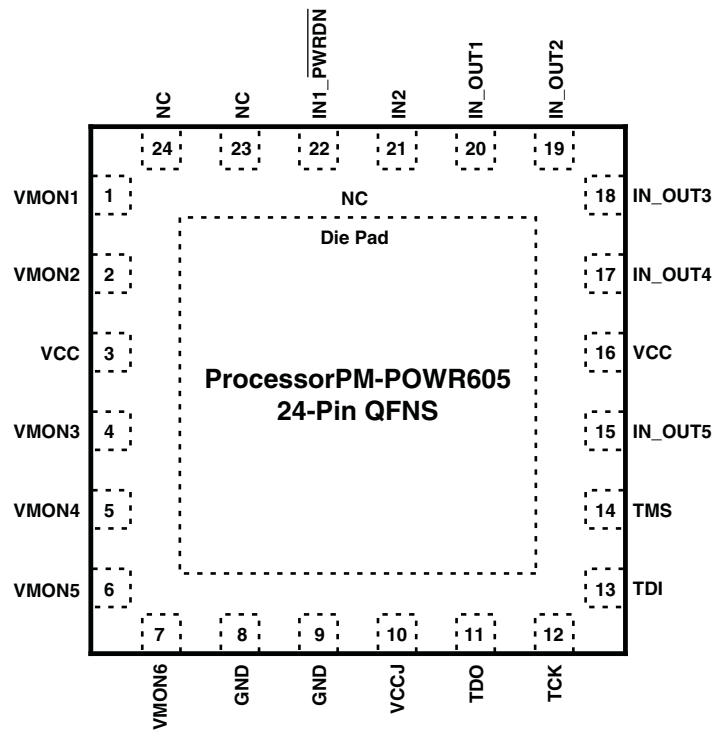

Technical Support Assistance

Hotline: 1-800-LATTICE (North America)
+1-408-826-6002 (Outside North America)
e-mail: isppacs@latticesemi.com
Internet: www.latticesemi.com

Revision History

| Date | Version | Change Summary |
|---------------|---------|---|
| April 2009 | 01.0 | Initial release. |
| July 2009 | 01.1 | Further clarification of Initial Factory Configuration. |
| February 2012 | 01.2 | Updated document with new corporate logo. |

Компания «Океан Электроники» предлагает заключение долгосрочных отношений при поставках импортных электронных компонентов на взаимовыгодных условиях!

Наши преимущества:

- Поставка оригинальных импортных электронных компонентов напрямую с производств Америки, Европы и Азии, а так же с крупнейших складов мира;
- Широкая линейка поставок активных и пассивных импортных электронных компонентов (более 30 млн. наименований);
- Поставка сложных, дефицитных, либо снятых с производства позиций;
- Оперативные сроки поставки под заказ (от 5 рабочих дней);
- Экспресс доставка в любую точку России;
- Помощь Конструкторского Отдела и консультации квалифицированных инженеров;
- Техническая поддержка проекта, помощь в подборе аналогов, поставка прототипов;
- Поставка электронных компонентов под контролем ВП;
- Система менеджмента качества сертифицирована по Международному стандарту ISO 9001;
- При необходимости вся продукция военного и аэрокосмического назначения проходит испытания и сертификацию в лаборатории (по согласованию с заказчиком);
- Поставка специализированных компонентов военного и аэрокосмического уровня качества (Xilinx, Altera, Analog Devices, Intersil, Interpoint, Microsemi, Actel, Aeroflex, Peregrine, VPT, Syfer, Eurofarad, Texas Instruments, MS Kennedy, Miteq, Cobham, E2V, MA-COM, Hittite, Mini-Circuits, General Dynamics и др.);

Компания «Океан Электроники» является официальным дистрибьютором и эксклюзивным представителем в России одного из крупнейших производителей разъемов военного и аэрокосмического назначения «JONHON», а так же официальным дистрибьютором и эксклюзивным представителем в России производителя высокотехнологичных и надежных решений для передачи СВЧ сигналов «FORSTAR».



JONHON

«JONHON» (основан в 1970 г.)

Разъемы специального, военного и аэрокосмического назначения:

(Применяются в военной, авиационной, аэрокосмической, морской, железнодорожной, горно- и нефтедобывающей отраслях промышленности)

«FORSTAR» (основан в 1998 г.)

ВЧ соединители, коаксиальные кабели, кабельные сборки и микроволновые компоненты:

(Применяются в телекоммуникациях гражданского и специального назначения, в средствах связи, РЛС, а так же военной, авиационной и аэрокосмической отраслях промышленности).



Телефон: 8 (812) 309-75-97 (многоканальный)

Факс: 8 (812) 320-03-32

Электронная почта: ocean@oceanchips.ru

Web: <http://oceanchips.ru/>

Адрес: 198099, г. Санкт-Петербург, ул. Калинина, д. 2, корп. 4, лит. А