

# AVX 2pc/1pc Connector Solutions



Version 13.12

**AVX**  
A KYOCERA GROUP COMPANY



# Table of Contents



## 2 PIECE BOARD TO BOARD (BTB) AND WIRE TO BOARD (WTB)

### HORIZONTAL PLUG.....2-8

2 Way 2 Part PCB Strip Connector .....	3
3 Way 2 Part PCB Strip Connector .....	4
4 Way 2 Part PCB Strip Connector .....	5
5 Way 2 Part PCB Strip Connector .....	6
6 Way 2 Part PCB Strip Connector .....	7
Accessory Retaining Clip, Plug Assembly, Mated Assembly, Hand Insertion Tool .....	8

### CABLED PLUG: WTB.....9-17

2 Way 2 Part WTB Lighting Connector .....	10
3 Way 2 Part WTB Lighting Connector .....	11
4 Way 2 Part WTB Lighting Connector .....	12
5 Way 2 Part WTB Lighting Connector .....	13
6 Way 2 Part WTB Lighting Connector .....	14
Cover Accessory .....	15
Latch Accessory .....	16
Accessory Ordering Codes / 3 Assembled Options .....	17

### VERTICAL SMT PLUG.....18-23

2 Way 2 Part PCB Strip Connector .....	19
3 Way 2 Part PCB Strip Connector .....	20
4 Way 2 Part PCB Strip Connector .....	21
5 Way 2 Part PCB Strip Connector .....	22
6 Way 2 Part PCB Strip Connector .....	23

### IDC PLUG: WTB.....24-36

2 Way Through Wire Cap .....	25
3 Way Through Wire Cap .....	26
4 Way Through Wire Cap .....	27
5 Way Through Wire Cap .....	28
6 Way Through Wire Cap .....	29
2 Way Wire Stop Cap .....	30
3 Way Wire Stop Cap .....	31
4 Way Wire Stop Cap .....	32
5 Way Wire Stop Cap .....	33
6 Way Wire Stop Cap .....	34
Assembly Support Block, Insertion Tool .....	35
Assembly .....	36

### HORIZONTAL SOCKET.....37-42

2 Way 2 Part PCB Strip Connector .....	38
3 Way 2 Part PCB Strip Connector .....	39
4 Way 2 Part PCB Strip Connector .....	40
5 Way 2 Part PCB Strip Connector .....	41
6 Way 2 Part PCB Strip Connector .....	42

### TOP LOAD SOCKET.....43-49

2 Way 2 Part PCB Strip Connector .....	44
3 Way 2 Part PCB Strip Connector .....	45
4 Way 2 Part PCB Strip Connector .....	46
5 Way 2 Part PCB Strip Connector .....	47
6 Way 2 Part PCB Strip Connector .....	48
Assembly .....	49

### IDC SOCKET: WTB.....50-62

2 Way Through Wire Cap .....	51
3 Way Through Wire Cap .....	52
4 Way Through Wire Cap .....	53
5 Way Through Wire Cap .....	54
6 Way Through Wire Cap .....	55
2 Way Wire Stop Cap .....	56
3 Way Wire Stop Cap .....	57
4 Way Wire Stop Cap .....	58
5 Way Wire Stop Cap .....	59
6 Way Wire Stop Cap .....	60
Assembly Support Block, Insertion Tool .....	61
Assembly .....	62

## SHORTING SOCKET.....63-64

### COPLANAR BTB CONTACT SYSTEM.....65-69

401 Plug SMT .....	66
402 Socket SMT .....	67
Board to Board Assembly .....	68
Simple Compact Wired Plug Assemblies .....	69

## ONE PIECE BOARD TO BOARD (BTB)

### ONE PIECE CARD EDGE.....70-74

2 Way Single Part PCB Strip Connector .....	71
3 Way Single Part PCB Strip Connector .....	72
4 Way Single Part PCB Strip Connector .....	73
5 Way Single Part PCB Strip Connector .....	74

### ONE PIECE BOTTOM ENTRY CARD EDGE.....75-84

2 Way Through the Board Mating Edge Card Connector .....	76
3 Way Through the Board Mating Edge Card Connector .....	77
4 Way Through the Board Mating Edge Card Connector .....	78
5 Way Through the Board Mating Edge Card Connector .....	79
6 Way Through the Board Mating Edge Card Connector .....	80
Through the Board Mating Edge Card Connector – With Cap .....	81
Through the Board Mating Edge Card Connector – Mating PCB .....	82
Assembly .....	83
Accessory – Protection Cap .....	84

### ONE PIECE TOP ENTRY CARD EDGE.....85-92

2 Way Top Mounting Edge Card Connector .....	86
3 Way Top Mounting Edge Card Connector .....	87
4 Way Top Mounting Edge Card Connector .....	88
5 Way Top Mounting Edge Card Connector .....	89
6 Way Top Mounting Edge Card Connector .....	90
Top Mounting Edge Card Connector – Mating PCB .....	91
Assembly .....	92

### ONE PIECE OPEN ENDED CARD EDGE.....93-97

4 Way Single Part PCB Strip Connector – Open Ended .....	94
6 Way Single Part PCB Strip Connector – Open Ended .....	95
8 Way Single Part PCB Strip Connector – Open Ended .....	96
10 Way Single Part PCB Strip Connector – Open Ended .....	97

### BTB COMPRESSION.....98-103

2 Way Low Profile Connector – No Stop .....	99
3 Way Low Profile Connector – No Stop .....	100
2 Way Low Profile Connector – With Stop .....	101
3 Way Low Profile Connector – With Stop .....	102
Low Profile Mating Pads .....	103

### SINGLE COMPRESSION CONTACT.....104-106

Nominal Working Height 1.00mm .....	105
Nominal Working Height 1.50mm .....	106



# Horizontal Plug

## Series 10-9159



The 9159 series of Board-to-Board interconnect system allows two PCB's to be mated end-to-end creating strips of LED lighting. Designed specifically for the unique Solid State Lighting (SSL) market requiring coplanar (horizontal-to-horizontal) PCB mating with a 5 Amp current rating in the smallest package available. These single sided SMT connectors are perfect for both FR4 and metal boards where you need to butt the boards up together to minimize separation. Availability of both white and black insulation colors make them perfect for lighting as well as industrial applications. With sizes from 2p-6p, these high reliability connectors boast gold plated beryllium copper receptacle contacts for harsh environments.

### APPLICATIONS

- Coplanar PCB mating in SSL products
- LED linear lighting strips
- Application Notes: refer to 201-01-123

### FEATURES AND BENEFITS

- Single sided SMT: supports FR4 and metal PCB's
- 5 Amp current rating: exceeds general market needs
- 5.5mm mated width: minimizes PCB space to decrease LED pitch
- Gold plated BeCu spring contacts: reliability for harsh environments
- Optional retaining clip: provides positive connector mating during vibration
- Available in white: supports SSL market preferences

### ELECTRICAL

- Current Rating: 5 Amps / Contact
- Voltage Rating: 125 VAC

### ENVIRONMENTAL

- Operating Temperature: -40°C to +125°C

### MECHANICAL

- Insulator Material: Nylon: VL94VO
- Contact Material: BeCu / Phos Bronze
- Plating: Gold / Tin over Nickel
- Durability: 10 Cycles

### HOW TO ORDER

**10**  
Plug

**9159**  
Series

**XXX**  
Number of Ways

Code	No of Ways	Details
002	2	Page 3
003	3	Page 4
004	4	Page 5
005	5	Page 6
006	6	Page 7

Optional Retaining Clip  
Page 8

**1**  
2 Part PCB Strip Connector

**01**  
Connector Pitch  
01 = 3mm

**X**  
Color/Approval

Code	Color	Approval
1	White	Standard
9	White	UL Approved

**16**  
Plating Option

Code	Contact	Bracket
16	Gold in Contact Area Tin on Solder Tail	Tin all over



Certification: UL File #E90723



# Horizontal Plug

Series 10-9159



## PLUG 2 WAY 2 PART PCB STRIP CONNECTOR

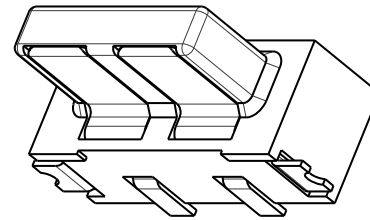
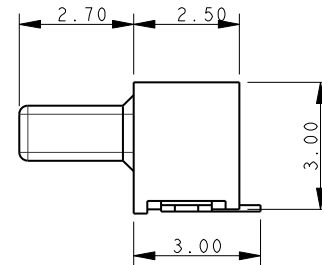
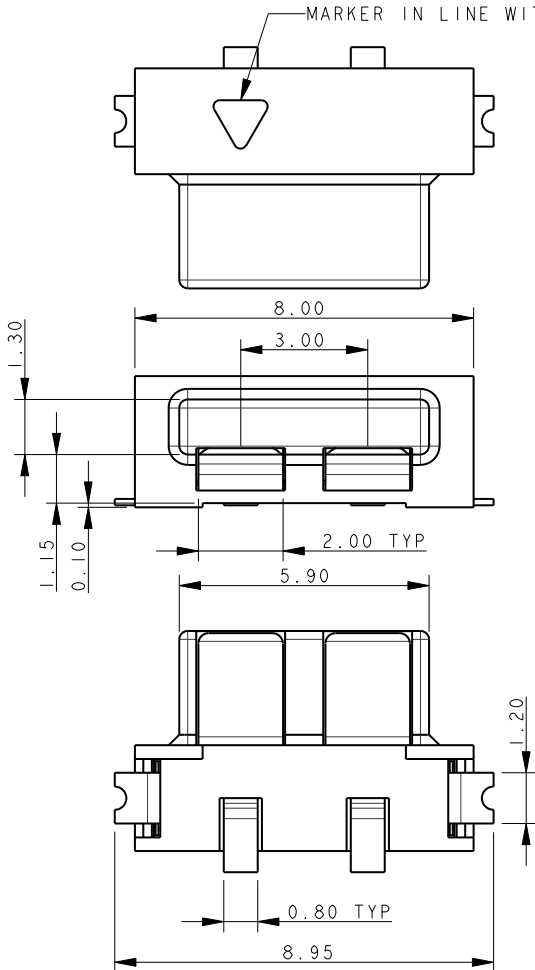

### NOTES:

1. FOR MORE INFORMATION REFER TO PRODUCT SPEC 201-01-119.
2. DIMENSIONS ARE REFERENCE DIMENSIONS UNLESS TOLERANCES.
3. INSULATOR MATERIAL: NYLON 46.
4. CONTACT MATERIAL: COPPER ALLOY, SELECTIVE GOLD OVER NICKEL TIN PLATED ON TAILS.
5. BRACKETS: COPPER ALLOY, TIN PLATED.
6. OUTLINE OF CONNECTOR.
7. PACKING TAPE AND REEL, QUANTITY 1400 PER REEL.
8. OPTIONAL RETAINING CLIP, SEE PAGE 8.

### 2 WAY PCB BOARD LAYOUT

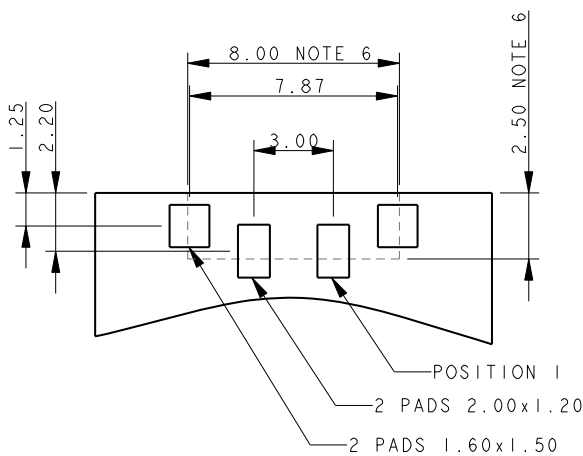

### PACKING DETAILS

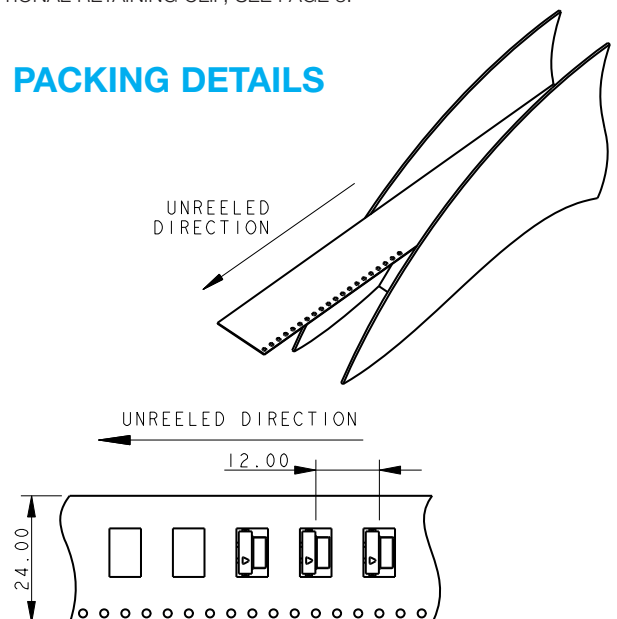

# Horizontal Plug

Series 10-9159



## PLUG 3 WAY 2 PART PCB STRIP CONNECTOR

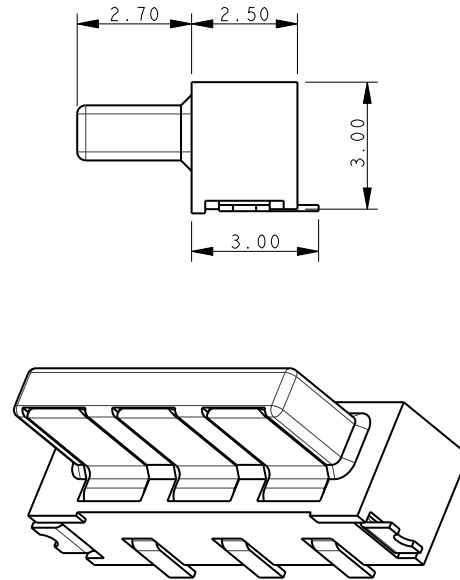
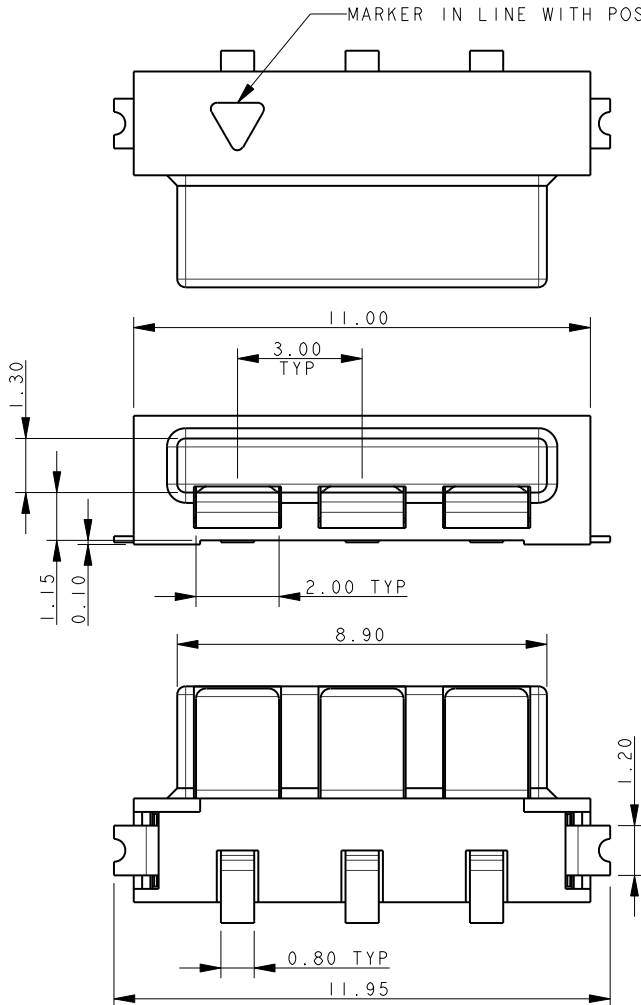

### NOTES:

1. FOR MORE INFORMATION REFER TO PRODUCT SPEC 201-01-119.
2. DIMENSIONS ARE REFERENCE DIMENSIONS UNLESS TOLERANCES.
3. INSULATOR MATERIAL: NYLON 46.
4. CONTACT MATERIAL: COPPER ALLOY, SELECTIVE GOLD OVER NICKEL TIN PLATED ON TAILS.
5. BRACKETS: COPPER ALLOY, TIN PLATED.
6. OUTLINE OF CONNECTOR.
7. PACKING TAPE AND REEL, QUANTITY 1400 PER REEL.
8. OPTIONAL RETAINING CLIP, SEE PAGE 8.

## 3 WAY PCB BOARD LAYOUT

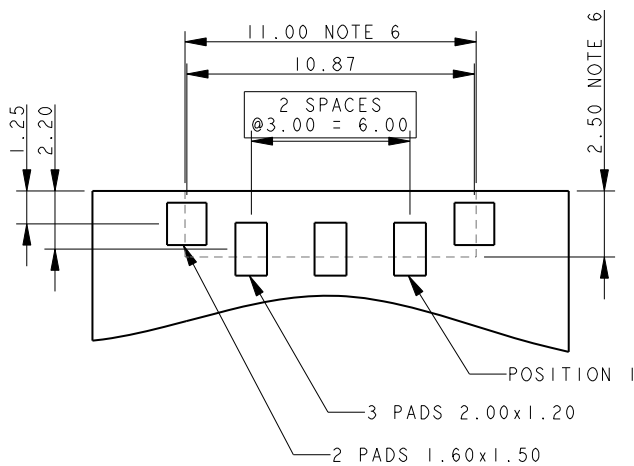

## PACKING DETAILS

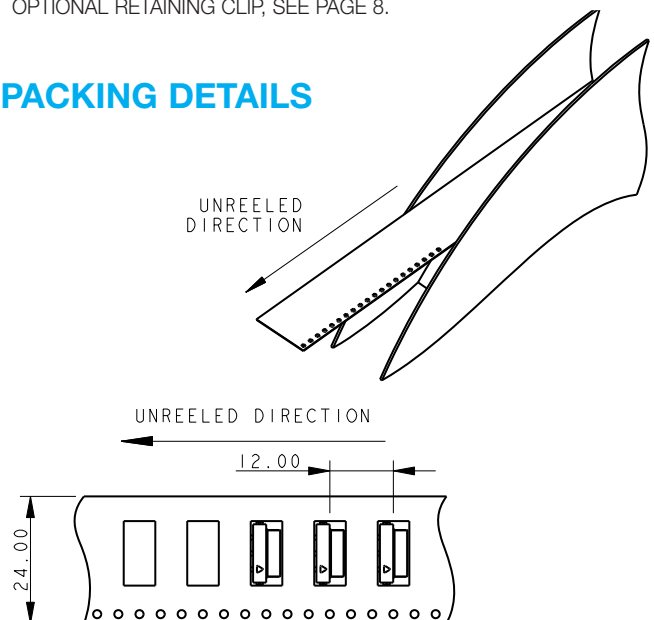

# Horizontal Plug

Series 10-9159



## PLUG 4 WAY 2 PART PCB STRIP CONNECTOR

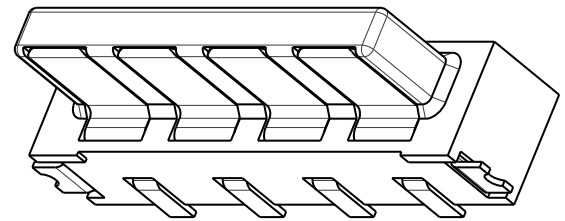
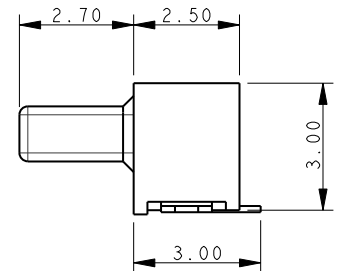
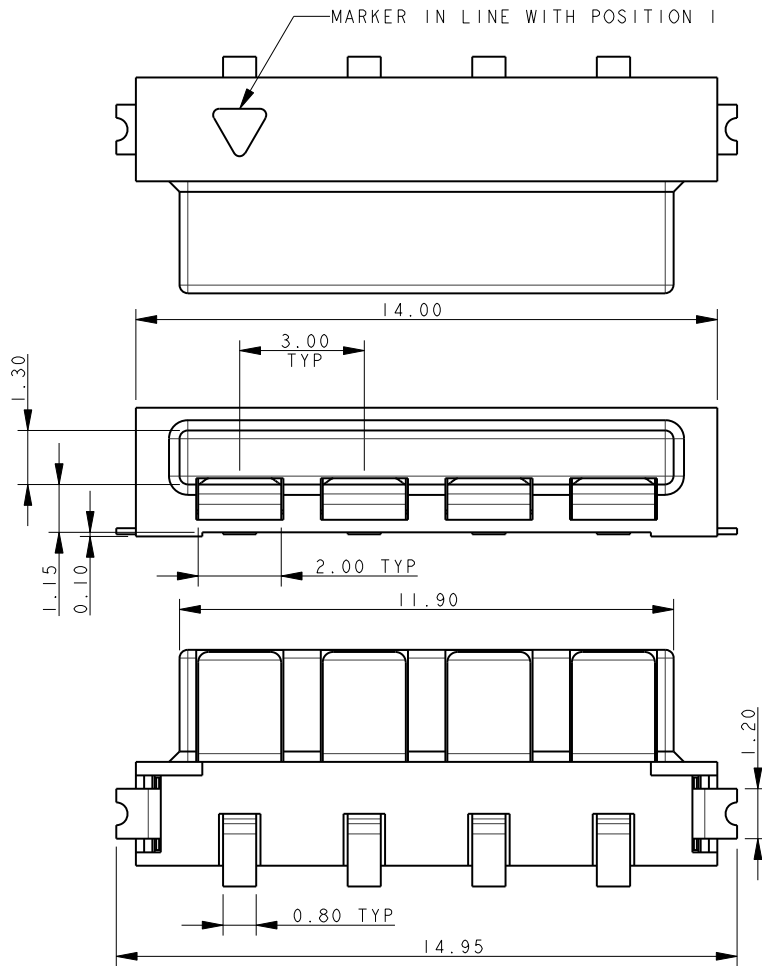

### NOTES:

1. FOR MORE INFORMATION REFER TO PRODUCT SPEC 201-01-119.
2. DIMENSIONS ARE REFERENCE DIMENSIONS UNLESS TOLERANCES.
3. INSULATOR MATERIAL: NYLON 46.
4. CONTACT MATERIAL: COPPER ALLOY, SELECTIVE GOLD OVER NICKEL TIN PLATED ON TAILS.
5. BRACKETS: COPPER ALLOY, TIN PLATED.
6. OUTLINE OF CONNECTOR.
7. PACKING TAPE AND REEL, QUANTITY 1400 PER REEL.
8. OPTIONAL RETAINING CLIP, SEE PAGE 8.

## 4 WAY PCB BOARD LAYOUT

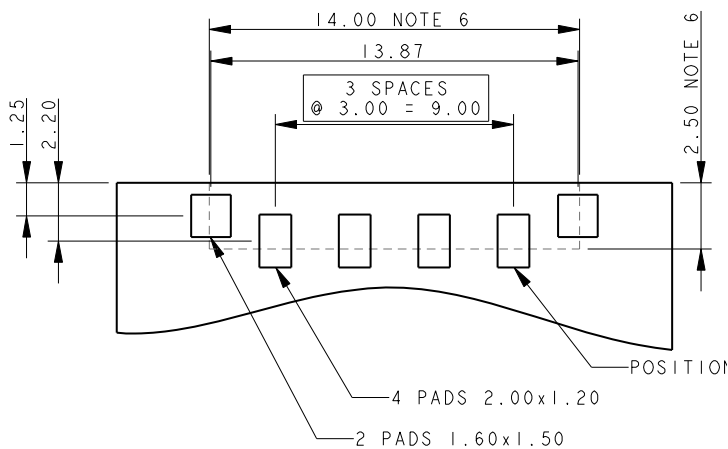

## PACKING DETAILS

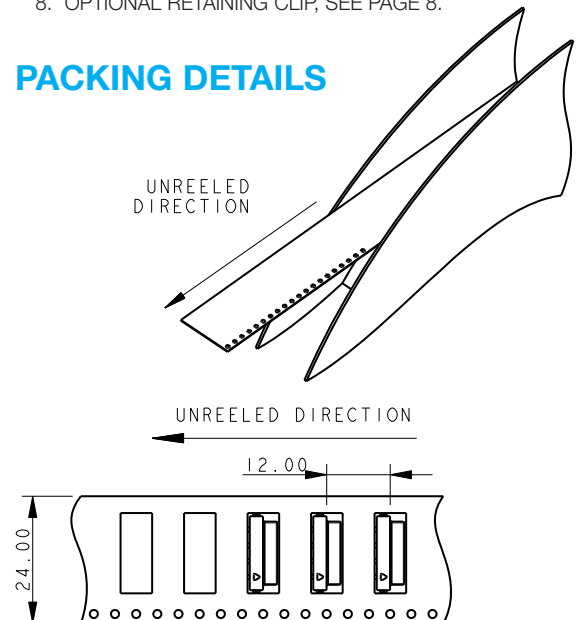

# Horizontal Plug

Series 10-9159



## PLUG 5 WAY 2 PART PCB STRIP CONNECTOR

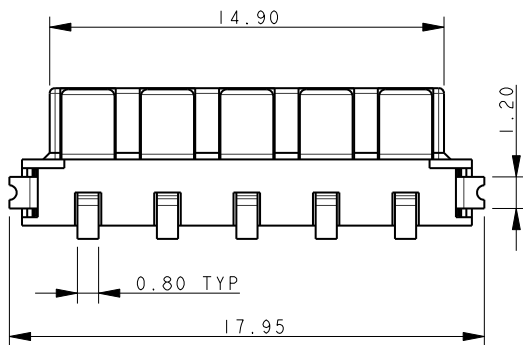
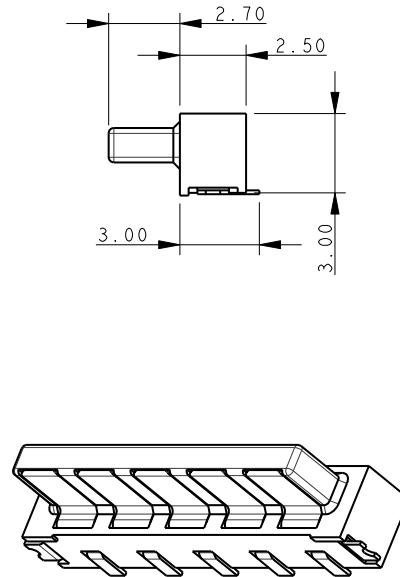
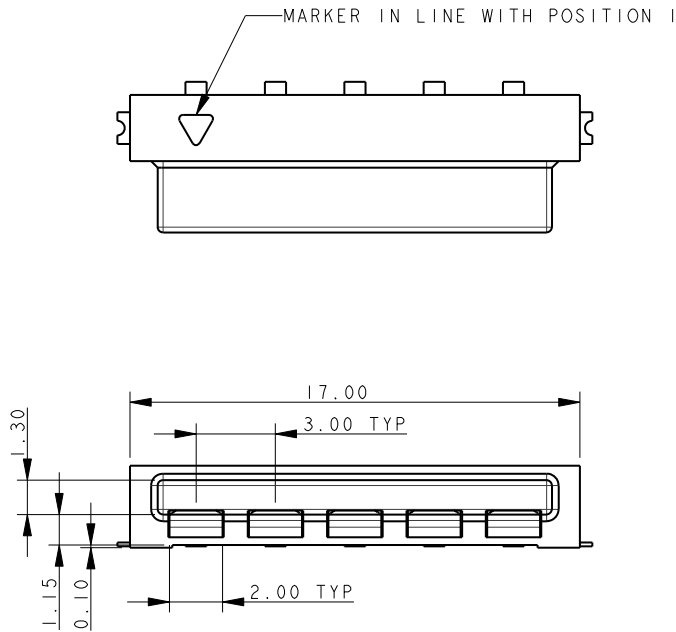

### NOTES:

1. FOR MORE INFORMATION REFER TO PRODUCT SPEC 201-01-119.
2. DIMENSIONS ARE REFERENCE DIMENSIONS UNLESS TOLERANCES.
3. INSULATOR MATERIAL: NYLON 46.
4. CONTACT MATERIAL: COPPER ALLOY, SELECTIVE GOLD OVER NICKEL TIN PLATED ON TAILS.
5. BRACKETS: COPPER ALLOY, TIN PLATED.
6. OUTLINE OF CONNECTOR.
7. PACKING TAPE AND REEL, QUANTITY 1400 PER REEL.
8. OPTIONAL RETAINING CLIP, SEE PAGE 8.

### 5 WAY PCB BOARD LAYOUT

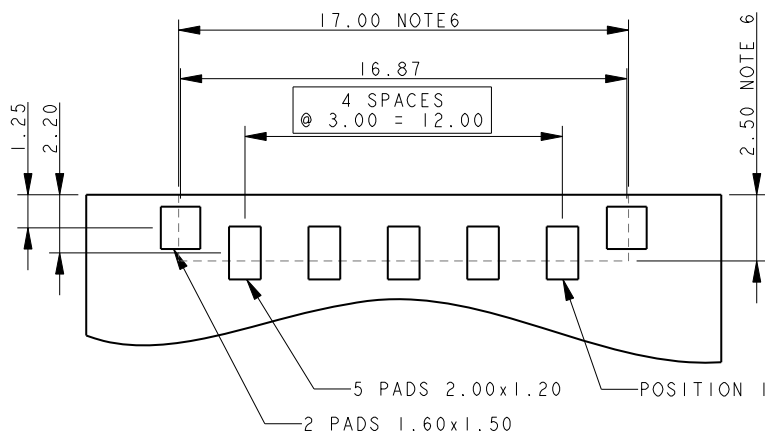

### PACKING DETAILS

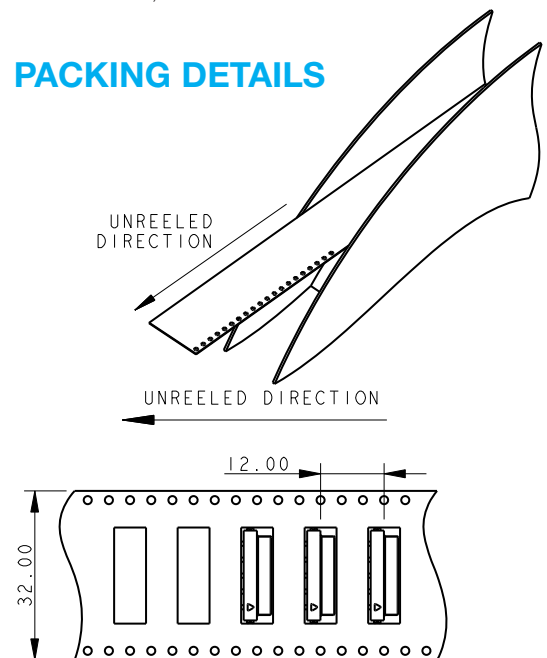



# Horizontal Plug

Series 10-9159



## PLUG 6 WAY 2 PART PCB STRIP CONNECTOR

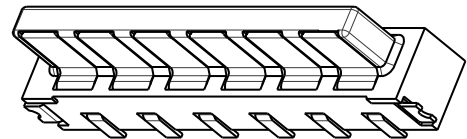
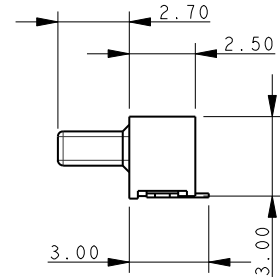
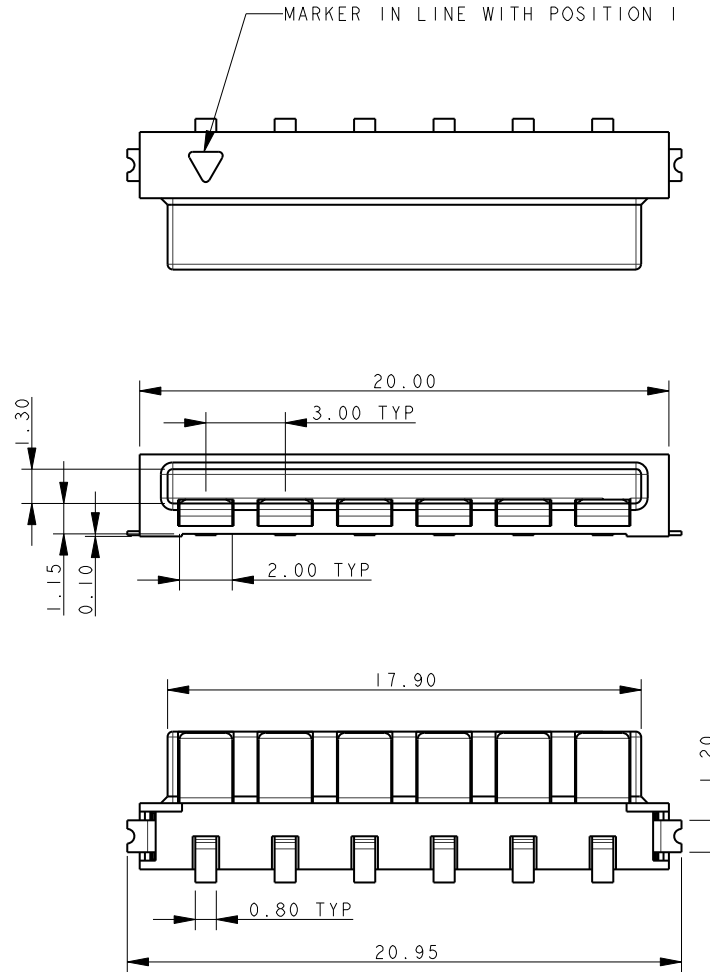

### NOTES:

1. FOR MORE INFORMATION REFER TO PRODUCT SPEC 201-01-119.
2. DIMENSIONS ARE REFERENCE DIMENSIONS UNLESS TOLERANCES.
3. INSULATOR MATERIAL: NYLON 46.
4. CONTACT MATERIAL: COPPER ALLOY, SELECTIVE GOLD OVER NICKEL TIN PLATED ON TAILS.
5. BRACKETS: COPPER ALLOY, TIN PLATED.
6. OUTLINE OF CONNECTOR.
7. PACKING TAPE AND REEL, QUANTITY 1400 PER REEL.
8. OPTIONAL RETAINING CLIP, SEE PAGE 8.

### 6 WAY PCB BOARD LAYOUT

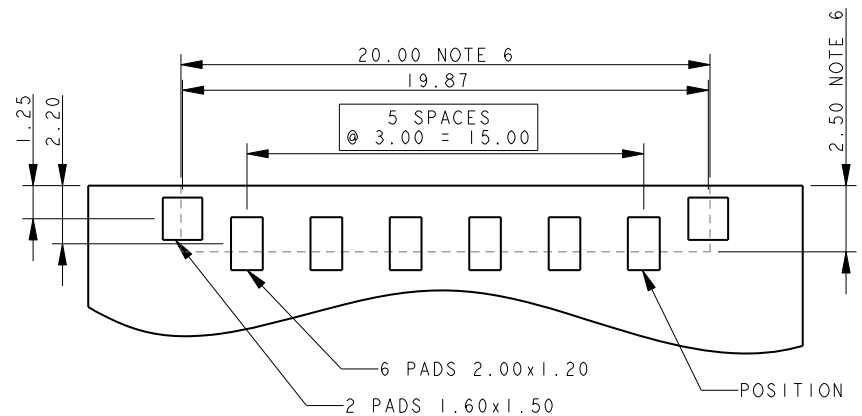

### PACKING DETAILS

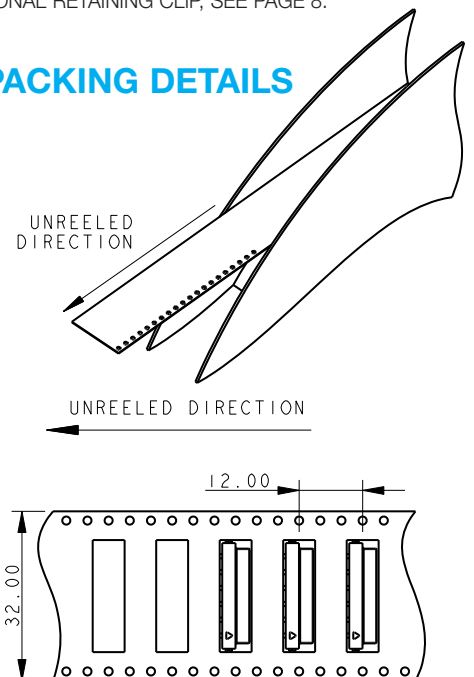

# Horizontal Plug

Series 10-9159



## 80-9159-4200-00-000 ACCESSORY RETAINING CLIP

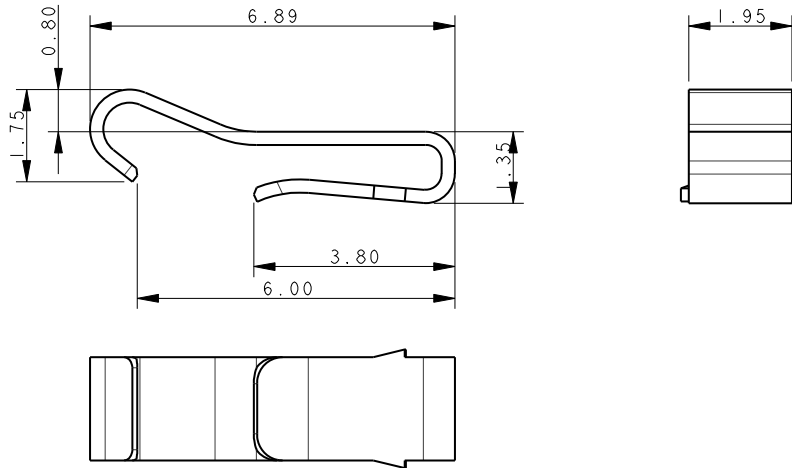

## PLUG ASSEMBLY – FOR REFERENCE ONLY

CLIP INSERTED INTO 10-9159-00X-101-X06

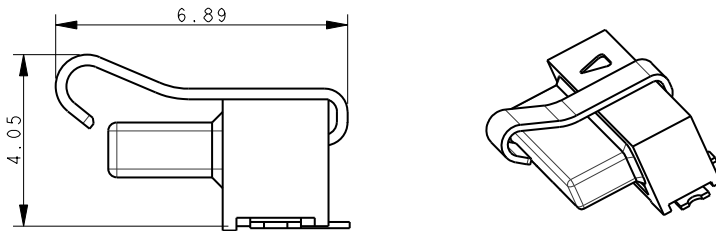

## HAND INSERTION TOOL

06-9159-7025-01-000

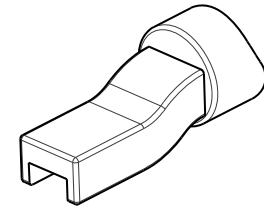

## MATED ASSEMBLY – FOR REFERENCE ONLY

10-9159-00X-101-X06 MATED WITH 20-9159-00X-X06

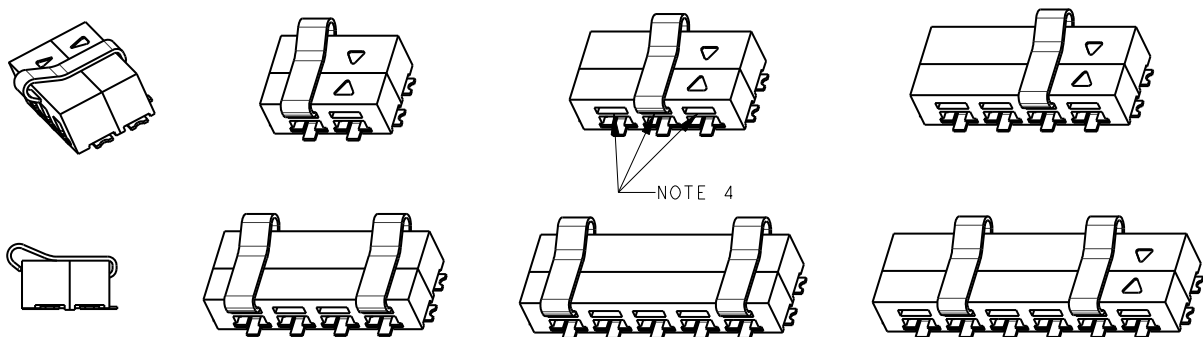

### NOTES:

1. CLIP TO RETAIN MATED PAIR PLUG AND SOCKET. NOT SUPPLIED WITH CONNECTOR.
2. MATERIAL: STAINLESS STEEL.
3. PACKING IN BAGS, 1400 PER BAG.
4. TAIL INSERTED INTO SLOT OF 9159 2 PART PLUG (10-9159-00X-101-006). LEADING EDGE CLIPS OVER SOCKET.
5. ALL DIMENSIONS SHOWN ARE REFERENCE DIMENSIONS.
6. RECOMMENDED 1 CLIP IN 2, 3 AND 4 WAY. 2 CLIPS IN 5 AND 6 WAY. POSITIONS AT CUSTOMER DISCRETION.

# Cable Plug

## Series 11-9159

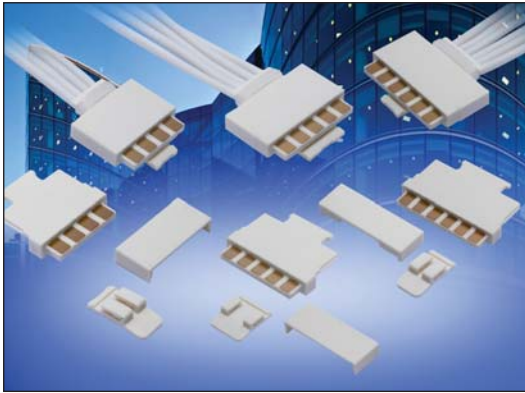

The 9159 series of Board-to-Board interconnect system allows two PCB's to be mated end-to-end creating strips of LED lighting. Designed specifically for the unique Solid State Lighting (SSL) market requiring coplanar (horizontal-to-horizontal) PCB mating with a 5 Amp current rating in the smallest package available. The cabled plug was developed to bring power and signals onto the PCB's while keeping the same board level interface. This allows the designer to build a single PCB with a receptacle on one end and a plug on the other end to minimize cost and inventory. Regardless of where the PCB is used in the system, the cabled plug connector will then create the connection to the outside world. The optional latch can be inserted into the plug housing to assure positive attachment to the PCB in harsh environments without having to change the PCB connector.

### APPLICATIONS

- Provided Wire-to-Board capabilities to standard 9159 2-Piece connector system
- Application Notes: refer to 201-01-123

### FEATURES AND BENEFITS

- Mates with standard horizontal socket: no need to change any connectors
- 5 Amp current rating: exceeds general market needs
- Wires are soldered into connector with tie wrap strain relief: simplicity
- Optional latch: provides positive attachment to PCB connector
- Available in white: supports SSL market preferences

### ELECTRICAL

- Current Rating: 5 Amps / Contact
- Voltage Rating: 125 VAC

### ENVIRONMENTAL

- Operating Temperature: -40°C to +125°C

### MECHANICAL

- Insulator Material: Nylon: VL94VO
- Contact Material: BeCu / Phos Bronze
- Plating: Gold / Tin over Nickel
- Durability: 10 Cycles

### HOW TO ORDER

<p><b>11</b></p> <p>Prefix</p> <p>Wire Plug Soldered Terminations</p>	<p><b>9159</b></p> <p>Series</p>	<p><b>XXX</b></p> <p>Number of Ways</p> <table border="1"> <thead> <tr> <th>Code</th> <th>No of Ways</th> <th>Details</th> </tr> </thead> <tbody> <tr> <td>002</td> <td>2</td> <td>Page 10</td> </tr> <tr> <td>003</td> <td>3</td> <td>Page 11</td> </tr> <tr> <td>004</td> <td>4</td> <td>Page 12</td> </tr> <tr> <td>005</td> <td>5</td> <td>Page 13</td> </tr> <tr> <td>006</td> <td>6</td> <td>Page 14</td> </tr> </tbody> </table> <p><b>Optional Cover</b> See page 15 for ordering code</p> <p><b>Optional Latch</b> See page 16 for ordering code</p>	Code	No of Ways	Details	002	2	Page 10	003	3	Page 11	004	4	Page 12	005	5	Page 13	006	6	Page 14	<p><b>1</b></p> <p>2 Part PCB Strip Connector</p>	<p><b>01</b></p> <p>Connector Pitch 01 = 3mm</p>	<p><b>X</b></p> <p>Color/Approval</p> <table border="1"> <thead> <tr> <th>Code</th> <th>Color</th> <th>Approval</th> </tr> </thead> <tbody> <tr> <td>1</td> <td>White</td> <td>Standard</td> </tr> <tr> <td>9</td> <td>White</td> <td>UL Approved</td> </tr> </tbody> </table>	Code	Color	Approval	1	White	Standard	9	White	UL Approved	<p><b>16</b></p> <p>Plating Option</p> <table border="1"> <thead> <tr> <th>Code</th> <th>Contact</th> </tr> </thead> <tbody> <tr> <td>16</td> <td>Gold in Contact Area Tin on Solder Tail</td> </tr> </tbody> </table>	Code	Contact	16	Gold in Contact Area Tin on Solder Tail
Code	No of Ways	Details																																			
002	2	Page 10																																			
003	3	Page 11																																			
004	4	Page 12																																			
005	5	Page 13																																			
006	6	Page 14																																			
Code	Color	Approval																																			
1	White	Standard																																			
9	White	UL Approved																																			
Code	Contact																																				
16	Gold in Contact Area Tin on Solder Tail																																				



NOTES: Connectors are supplied with cable ties (see page 17).  
Covers/Latches are sold separately (see pages 15-16 for ordering codes).

Certification: UL File #E90723



# Cable Plug

Series 11-9159



## PLUG WIRED 2 WAY 2 PART 9159 LIGHTING CONNECTOR

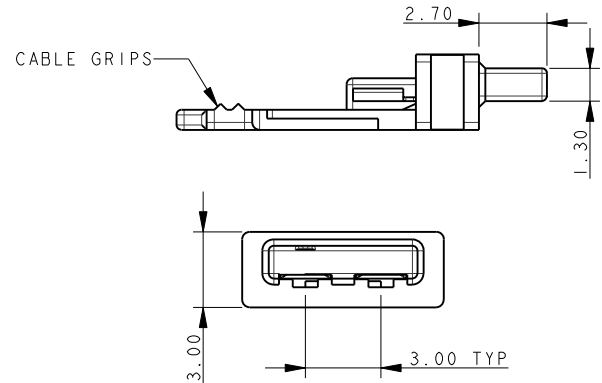
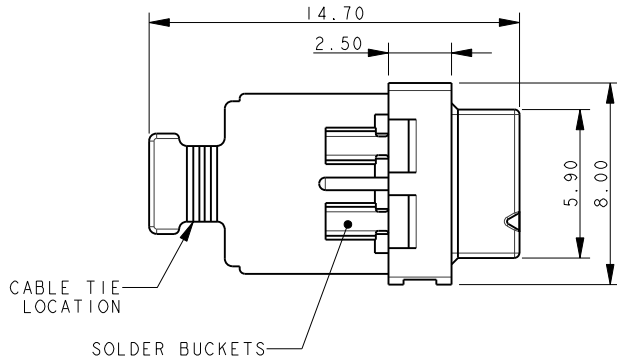

### NOTES:

1. FOR MORE INFORMATION REFER TO PRODUCT SPEC 201-01-119.
2. CABLE TIE SUPPLIED FOR WIRE RETENTION, ATTACHED TO EACH REEL. SPARES CAN BE ORDERED, REFER TO PAGE 17.
3. DIMENSIONS ARE REFERENCE DIMENSIONS UNLESS TOLERANCED.
4. INSULATOR MATERIAL: NYLON 46. COLOR REFER TO PAGE 9.
5. CONTACT MATERIAL: COPPER ALLOY, SELECTIVE GOLD OVER NICKEL TIN PLATED ON TAILS.
6. PACKING IN TAPE AND REEL, QUANTITY PER REEL 700.
7. FOR ACCESSORY COVERS AND LATCHES REFER TO PAGES 15 AND 16.

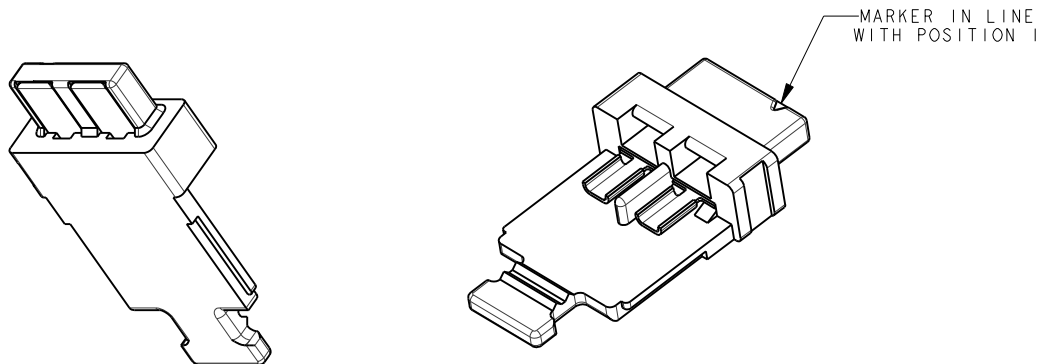

## PACKING DETAILS CABLE TIES SUPPLIED WITH EACH REEL

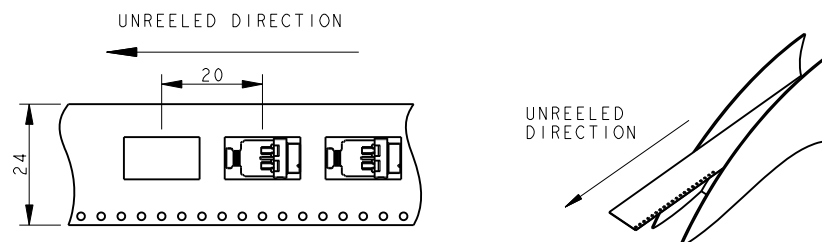

# Cable Plug

Series 11-9159



## PLUG WIRED 3 WAY 2 PART 9159 LIGHTING CONNECTOR

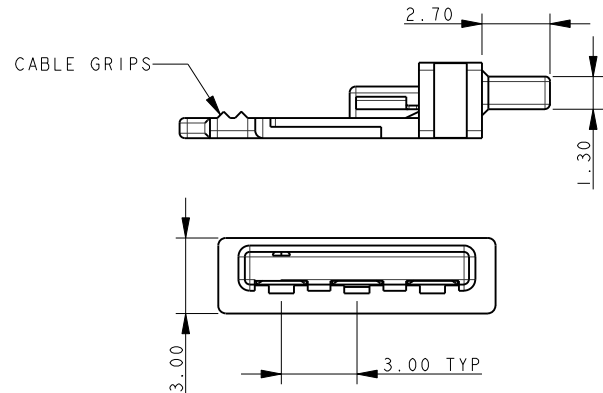
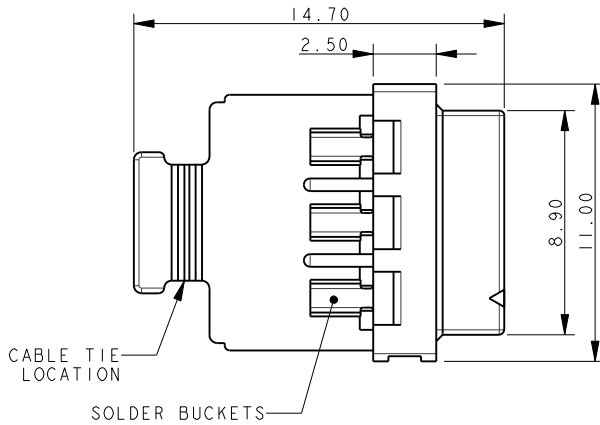

### NOTES:

1. FOR MORE INFORMATION REFER TO PRODUCT SPEC 201-01-119.
2. CABLE TIE SUPPLIED FOR WIRE RETENTION, ATTACHED TO EACH REEL. SPARES CAN BE ORDERED, REFER TO PAGE 17.
3. DIMENSIONS ARE REFERENCE DIMENSIONS UNLESS TOLERANCED.
4. INSULATOR MATERIAL: NYLON 46. COLOR REFER TO PAGE 9.
5. CONTACT MATERIAL: COPPER ALLOY, SELECTIVE GOLD OVER NICKEL TIN PLATED ON TAILS.
6. PACKING IN TAPE AND REEL, QUANTITY PER REEL 700.
7. FOR ACCESSORY COVERS AND LATCHES REFER TO PAGES 15 AND 16.

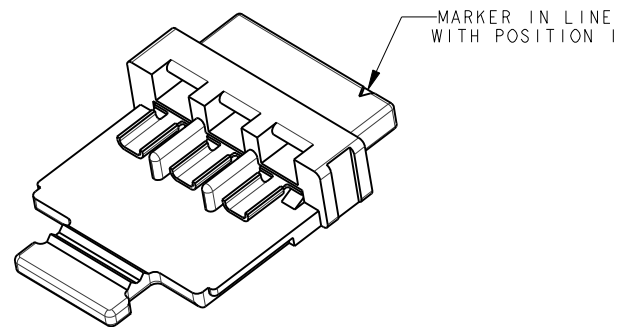
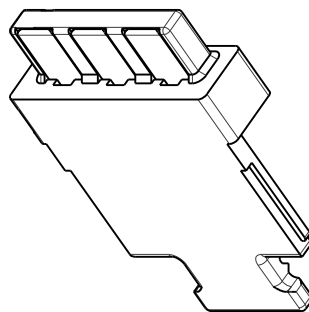

## PACKING DETAILS CABLE TIES SUPPLIED WITH EACH REEL

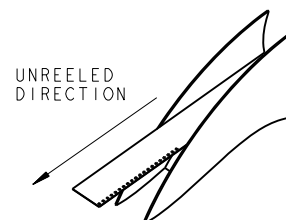
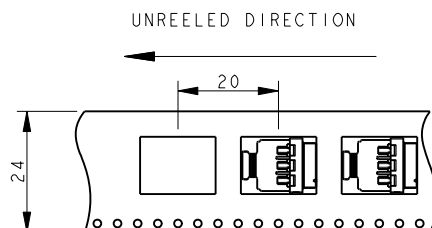

# Cable Plug

Series 11-9159



## PLUG WIRED 4 WAY 2 PART 9159 LIGHTING CONNECTOR

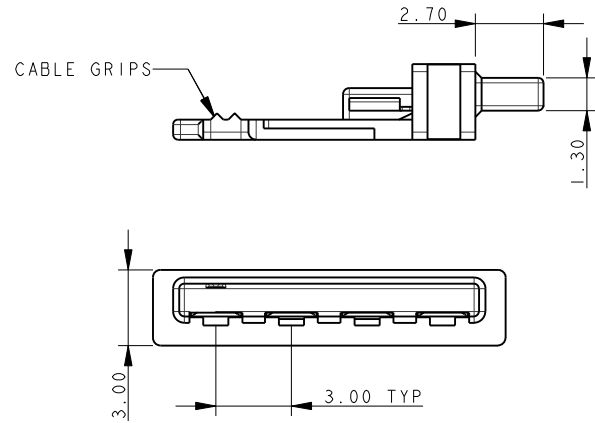
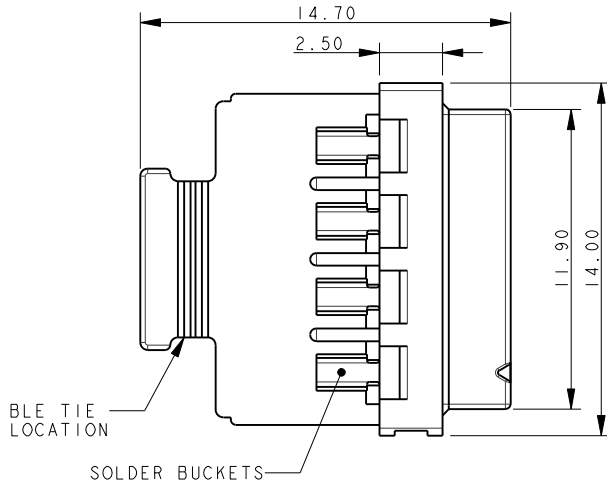

### NOTES:

1. FOR MORE INFORMATION REFER TO PRODUCT SPEC 201-01-119.
2. CABLE TIE SUPPLIED FOR WIRE RETENTION, ATTACHED TO EACH REEL. SPARES CAN BE ORDERED, REFER TO PAGE 17.
3. DIMENSIONS ARE REFERENCE DIMENSIONS UNLESS TOLERANCED.
4. INSULATOR MATERIAL: NYLON 46. COLOR REFER TO PAGE 9.
5. CONTACT MATERIAL: COPPER ALLOY, SELECTIVE GOLD OVER NICKEL TIN PLATED ON TAILS.
6. PACKING IN TAPE AND REEL, QUANTITY PER REEL 700.
7. FOR ACCESSORY COVERS AND LATCHES REFER TO PAGES 15 AND 16.

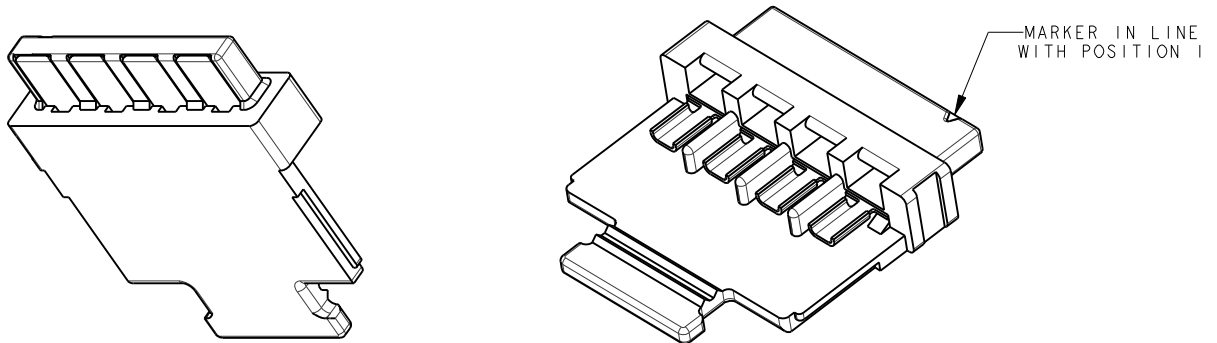

## PACKING DETAILS CABLE TIES SUPPLIED WITH EACH REEL

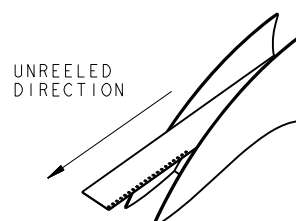
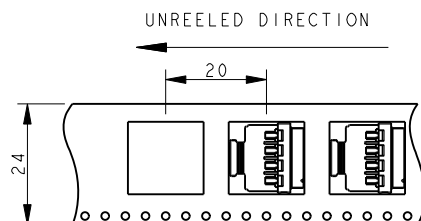

# Cable Plug

Series 11-9159



## PLUG WIRED 5 WAY 2 PART 9159 LIGHTING CONNECTOR

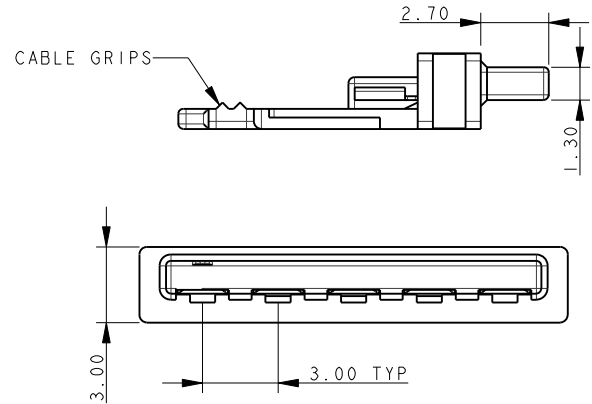
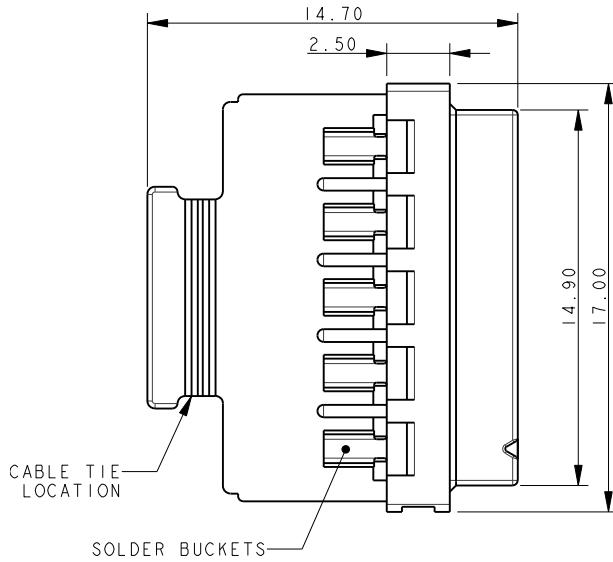

### NOTES:

1. FOR MORE INFORMATION REFER TO PRODUCT SPEC 201-01-119.
2. CABLE TIE SUPPLIED FOR WIRE RETENTION, ATTACHED TO EACH REEL. SPARES CAN BE ORDERED, REFER TO PAGE 17.
3. DIMENSIONS ARE REFERENCE DIMENSIONS UNLESS TOLERANCED.
4. INSULATOR MATERIAL: NYLON 46. COLOR REFER TO PAGE 9.
5. CONTACT MATERIAL: COPPER ALLOY, SELECTIVE GOLD OVER NICKEL TIN PLATED ON TAILS.
6. PACKING IN TAPE AND REEL, QUANTITY PER REEL 700.
7. FOR ACCESSORY COVERS AND LATCHES REFER TO PAGES 15 AND 16.

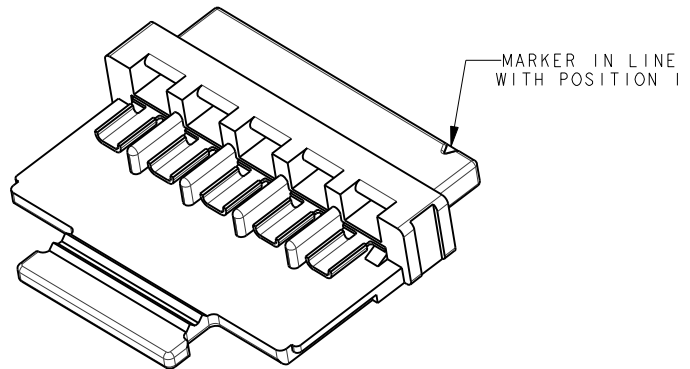
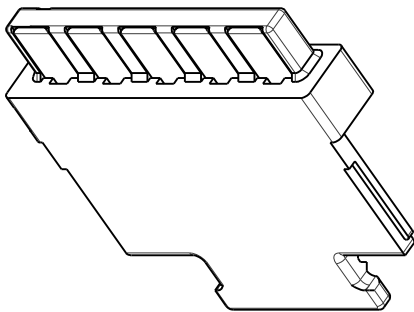

## PACKING DETAILS CABLE TIES SUPPLIED WITH EACH REEL

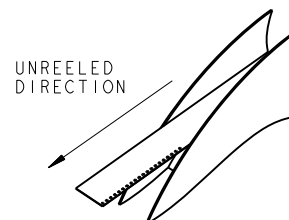
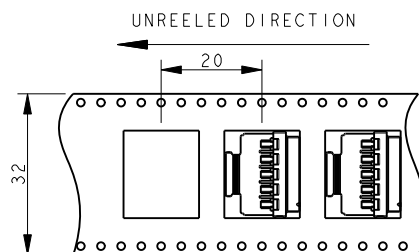

# Cable Plug

Series 11-9159



## PLUG WIRED 6 WAY 2 PART 9159 LIGHTING CONNECTOR

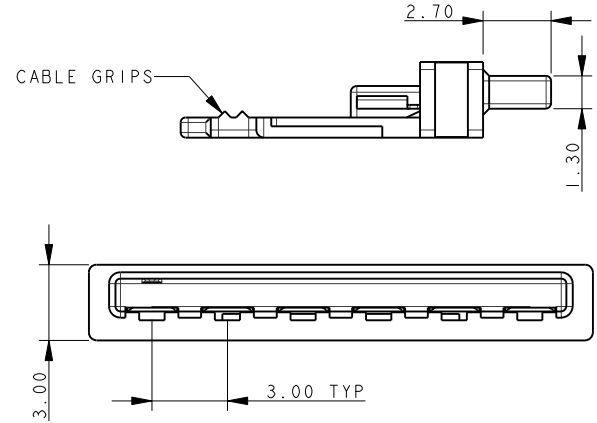
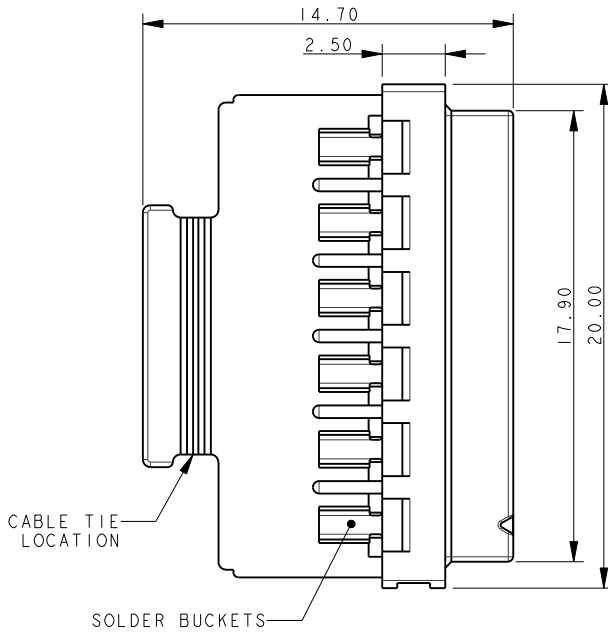

### NOTES:

1. FOR MORE INFORMATION REFER TO PRODUCT SPEC 201-01-119.
2. CABLE TIE SUPPLIED FOR WIRE RETENTION, ATTACHED TO EACH REEL. SPARES CAN BE ORDERED, REFER TO PAGE 17.
3. DIMENSIONS ARE REFERENCE DIMENSIONS UNLESS TOLERANCED.
4. INSULATOR MATERIAL: NYLON 46. COLOR REFER TO PAGE 9.
5. CONTACT MATERIAL: COPPER ALLOY, SELECTIVE GOLD OVER NICKEL TIN PLATED ON TAILS.
6. PACKING IN TAPE AND REEL, QUANTITY PER REEL 700.
7. FOR ACCESSORY COVERS AND LATCHES REFER TO PAGES 15 AND 16.

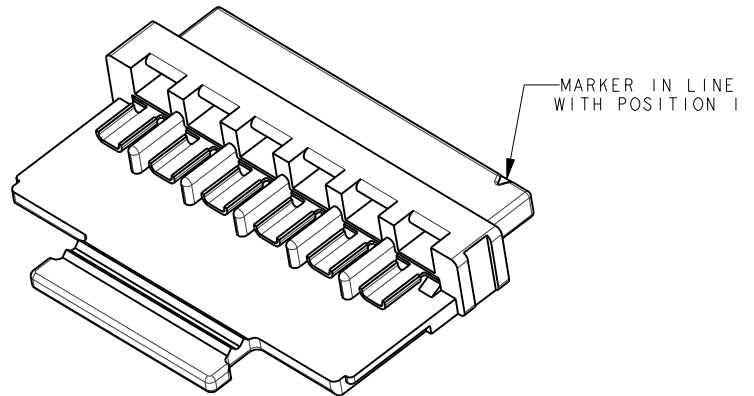
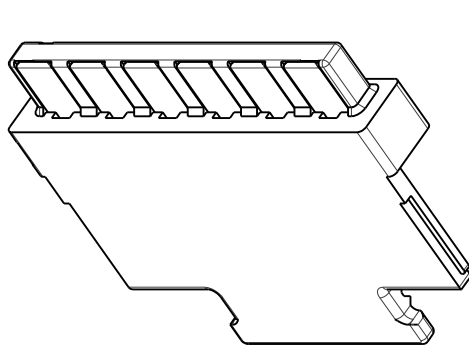

## PACKING DETAILS CABLE TIES SUPPLIED WITH EACH REEL

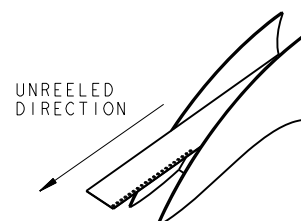
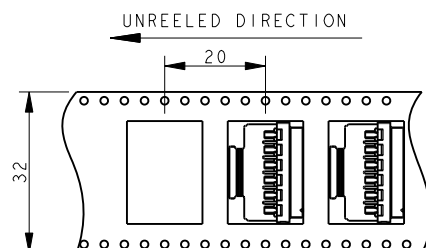



### PLUG WIRED COVERS

ACCESSORY NOT SUPPLIED WITH CONNECTOR ASSEMBLY

#### 2 WAY COVER 60-9159-3302-0X-000

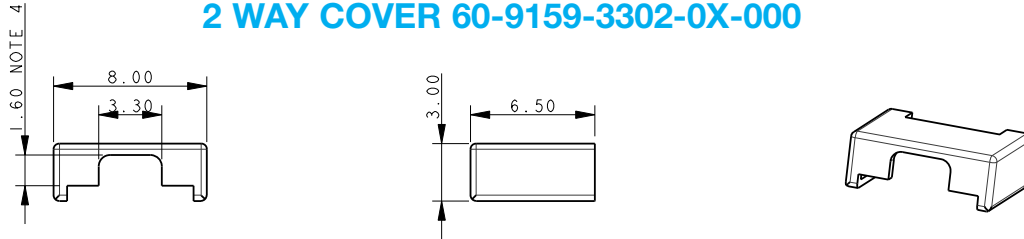

#### 3 WAY COVER 60-9159-3303-0X-000

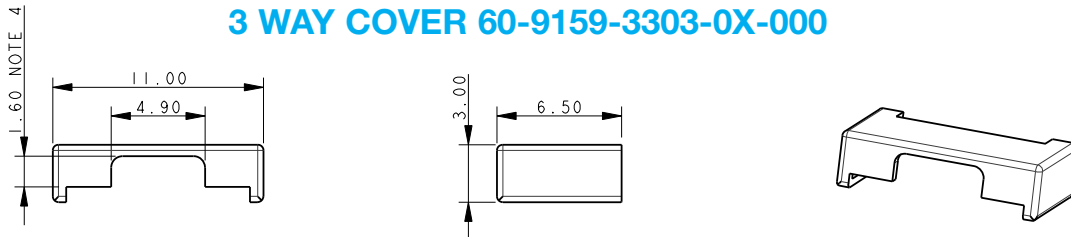

#### 4 WAY COVER 60-9159-3304-0X-000

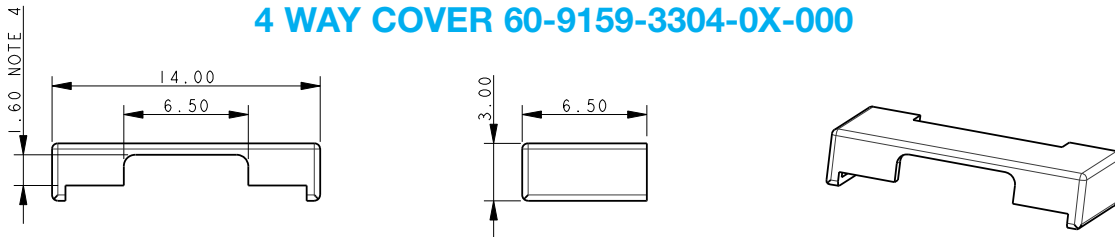

#### 5 WAY COVER 60-9159-3305-0X-000

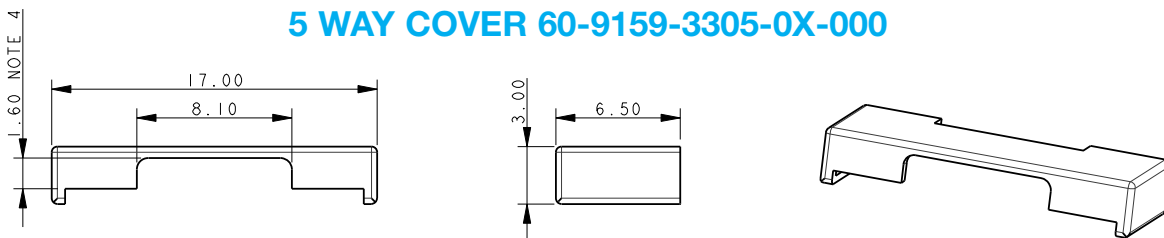

#### 6 WAY COVER 60-9159-3306-0X-000

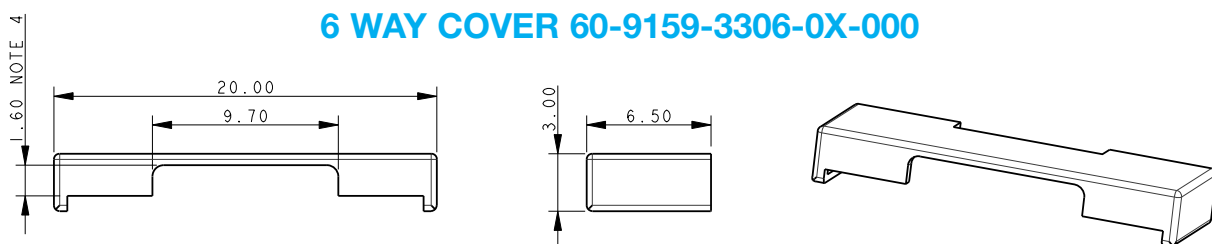

#### NOTES:

1. COVER (SLIDE ON) AVAILABLE TO PROTECT CABLE ENTRY.
2. OPTION COMPONENT. ORDER SEPARATELY.
3. PACKED IN BAGS, 1400 PIECES PER BAG.
4. MAXIMUM OUTER WIRE SIZE, 1.6MM DIAMETER INSULATION.
5. MATERIAL: GLASS FILLED NYLON 46. COLOR REFER TO PAGE 9.
6. COLOR OPTIONS SEE PAGE 9.
7. ALL DIMENSIONS ARE REFERENCED DIMENSIONS.
8. TO BE ASSEMBLED BEFORE CABLE TIE.

### PLUG WIRED LATCHES

ACCESSORY NOT SUPPLIED WITH CONNECTOR ASSEMBLY

#### LATCH 60-9159-3402-0X-000

USED ON 2, 4 AND 6 WAY ASSEMBLIES

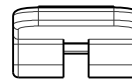
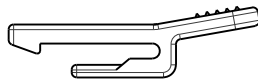
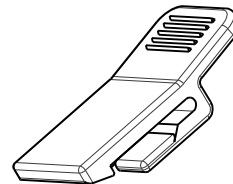
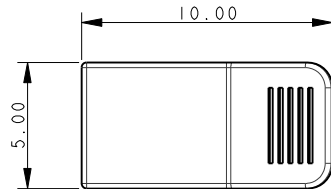

#### LATCH 60-9159-3403-0X-000

USED ON 3 AND 5 WAY ASSEMBLIES

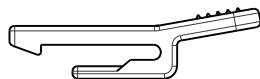
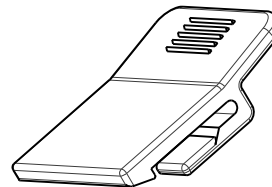
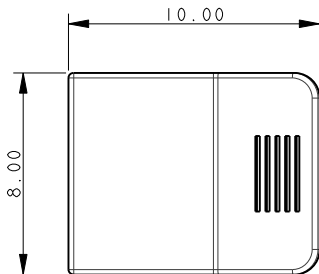

#### NOTES:

1. LATCH AVAILABLE TO RETAIN MATED PLUG.
2. OPTIONAL COMPONENT, ORDER SEPARATELY. SEE PAGE 17.
3. PACKAGED IN BAGS, 1400 PIECES PER BAG.
4. MATERIAL: GLASS FILLED NYLON 46. COLOR REFER TO PAGE 9.
5. ALL DIMENSIONS ARE REFERENCED DIMENSIONS.
6. TO BE ASSEMBLED BEFORE COVER.

### PLUG WIRED ACCESSORY ORDERING CODES

Connector Assembly Part Number	Optional Components Cover (see page 15)	Latch (see page 16)
11-9159-002-101-X16	60-9159-3302-0X-000	60-9159-3402-0X-000
11-9159-003-101-X16	60-9159-3303-0X-000	60-9159-3403-0X-000
11-9159-004-101-X16	60-9159-3304-0X-000	60-9159-3402-0X-000
11-9159-005-101-X16	60-9159-3305-0X-000	60-9159-3403-0X-000
11-9159-006-101-X16	60-9159-3306-0X-000	60-9159-3402-0X-000

"X" For color option refer to table on page 9.

### CABLE TIE

Supplied in bags with each reel of connector assemblies. Color White.  
For additional ties order code 90-2211-7092-00-000. Packed in bags, 700 pieces per bag.

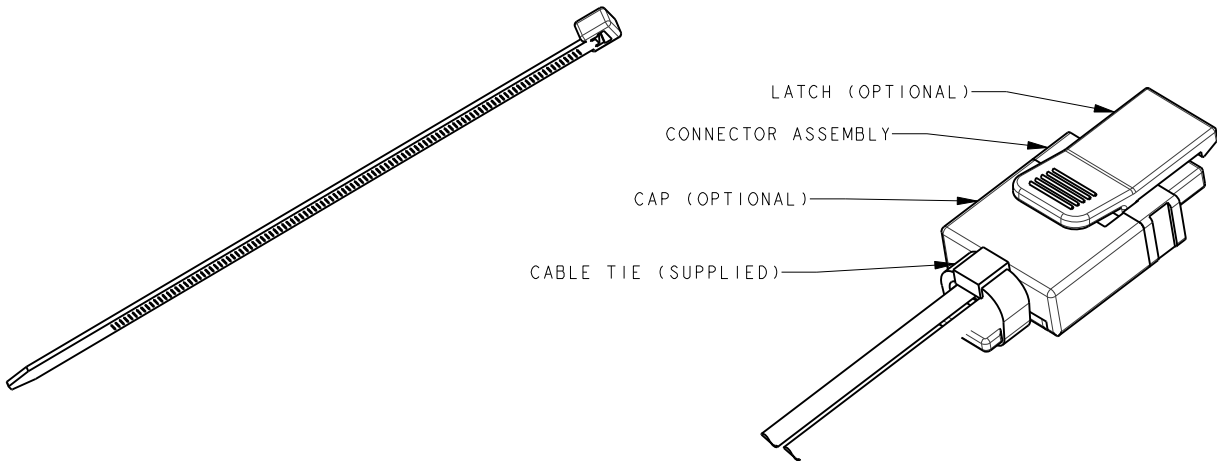

### PLUG WIRED 3 ASSEMBLY OPTIONS

#### PLUG ASSEMBLY

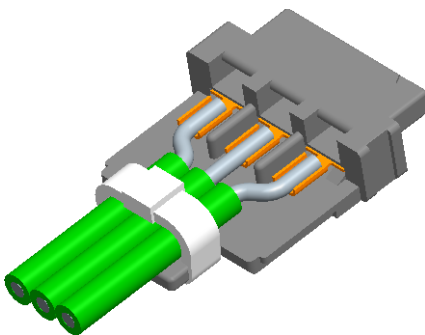

#### PLUG ASSEMBLY WITH COVER

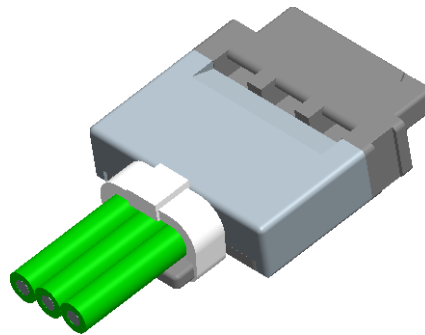

#### PLUG ASSEMBLY WITH COVER AND LATCH

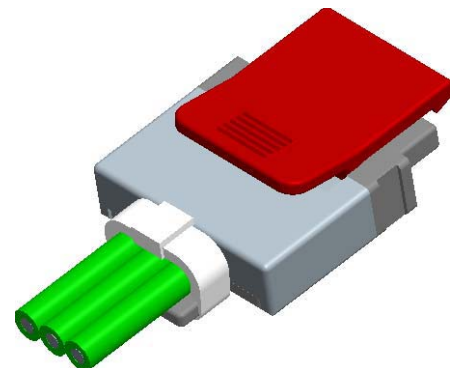

# Vertical SMT Plug



## Series 13-9159



AVX developed the 9159 Series of SMT connectors for co-planar PCB mating for the challenging Solid State Lighting (SSL) market. These connectors needed to be small, low in height, carry up to 5 Amps/contact and then function up to 125C for extended periods. This application has been very unique to the SSL market where PCB's are stacked end-to-end to create linear strip lighting in everything from office to transportation applications where products are exposed to harsh mechanical and environmental environments.

This vertical plug connector opens up the spectrum to include all commercial, industrial and transportation applications requiring perpendicular PCB mating and latching Wire-to-Board cabled sockets with an already proven connector system. With sizes from 2p-6p, these gold plated contacts mate with high spring force beryllium copper receptacle connectors.

### APPLICATIONS

- Allows assembly of PCB's at right angles
- Accepts 24-9159 IDC wired/cabled socket
- Reference application notes 201-01-123
- Reference Product Specification 201-01-119

### FEATURES AND BENEFITS

- Single sided SMT RoHS solder attachment
- Centrally located pick & place cap for easy placement
- Gold plated BeCu contact system for high reliability in harsh environments
- Available in white: supports SSL market preferences

### ELECTRICAL

- Current Rating: 5 Amps / Contact
- Voltage Rating: 125 VAC

### ENVIRONMENTAL

- Operating Temperature: -40°C to +125°C

### MECHANICAL

- Insulator Material: Nylon: UL94VO
- Contact Material: BeCu / Phos Bronze
- Plating: Gold / Tin over Nickel
- Durability: 10 Cycles

### HOW TO ORDER

<b>13</b>	<b>9159</b>	<b>XXX</b>	<b>1</b>	<b>01</b>	<b>X</b>	<b>16</b>																																	
<b>Prefix</b> Plug - Vertical Mount	<b>Series</b>	<b>Number of Ways</b>	<b>2 Part PCB Strip Connector</b>	<b>Connector Pitch</b> 01 = 3mm	<b>Color/Approval</b>	<b>Plating Option</b>																																	
		<table border="1"> <thead> <tr> <th>Code</th> <th>No of Ways</th> <th>Details</th> </tr> </thead> <tbody> <tr> <td>002</td> <td>2</td> <td>Page 19</td> </tr> <tr> <td>003</td> <td>3</td> <td>Page 20</td> </tr> <tr> <td>004</td> <td>4</td> <td>Page 21</td> </tr> <tr> <td>005</td> <td>5</td> <td>Page 22</td> </tr> <tr> <td>006</td> <td>6</td> <td>Page 23</td> </tr> </tbody> </table>	Code	No of Ways	Details	002	2	Page 19	003	3	Page 20	004	4	Page 21	005	5	Page 22	006	6	Page 23			<table border="1"> <thead> <tr> <th>Code</th> <th>Color</th> <th>Approval</th> </tr> </thead> <tbody> <tr> <td>1</td> <td>White</td> <td>Standard</td> </tr> <tr> <td>9</td> <td>White</td> <td>UL Approved</td> </tr> </tbody> </table>	Code	Color	Approval	1	White	Standard	9	White	UL Approved	<table border="1"> <thead> <tr> <th>Code</th> <th>Contact</th> </tr> </thead> <tbody> <tr> <td rowspan="3">16</td> <td>Gold in Contact Area Tin on Solder Tail</td> </tr> <tr> <td><b>Bracket</b></td> </tr> <tr> <td>Tin All Over</td> </tr> </tbody> </table>	Code	Contact	16	Gold in Contact Area Tin on Solder Tail	<b>Bracket</b>	Tin All Over
Code	No of Ways	Details																																					
002	2	Page 19																																					
003	3	Page 20																																					
004	4	Page 21																																					
005	5	Page 22																																					
006	6	Page 23																																					
Code	Color	Approval																																					
1	White	Standard																																					
9	White	UL Approved																																					
Code	Contact																																						
16	Gold in Contact Area Tin on Solder Tail																																						
	<b>Bracket</b>																																						
	Tin All Over																																						

Certification: UL File #E90723



# Vertical SMT Plug



Series 13-9159

## PLUG – VERTICAL MOUNT 2 WAY 2 PART PCB STRIP CONNECTOR

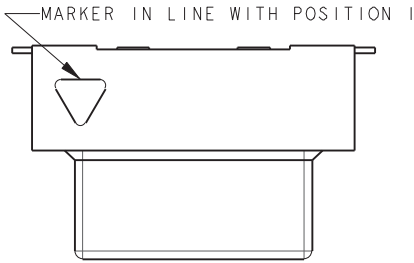

### NOTES:

1. FOR FULL PRODUCT SPECIFICATION STANDARD CONNECTORS REFER TO ELCO SPEC 201-01-119, UL COMPONENTS REFER TO ELCO SPEC 201-01-119UL. FOR APPLICATION NOTES REFER TO 201-01-123.
2. GENERAL TOLERANCE  $\pm 0.20$  UNLESS TOLERANCED.
3. INSULATOR MATERIAL: NYLON 46, UL94 V-0, COLOR REFER TO PAGE 18.
4. CONTACT MATERIAL: COPPER ALLOY, SELECTIVE GOLD OVER NICKEL, TIN PLATE ON TAILS.
5. BRACKETS: COPPER ALLOY, TIN PLATED.
6. OUTLINE OF CONNECTOR.
7. PACKING IN TAPE AND REEL, QUANTITY PER REEL 700.
8. PICK AND PLACE CAP TO BE REMOVED AFTER USE.
9. OPTIONAL SLOT: ONLY REQUIRED WHEN SOCKET HAS A LATCH, RADIUS ON ENDS OPTIONAL.

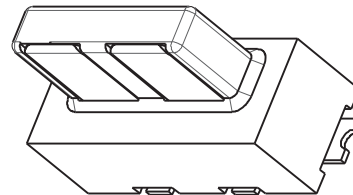
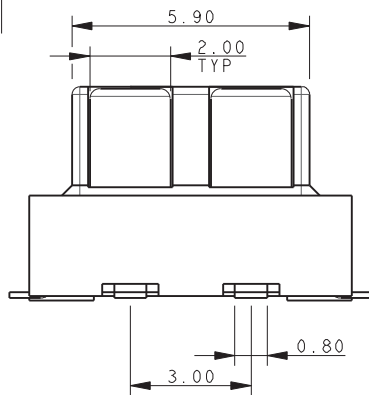
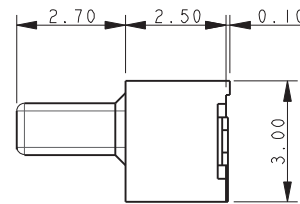
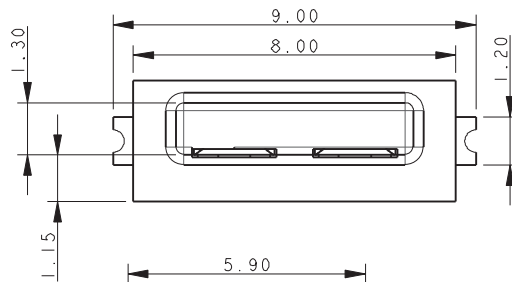

### 2 WAY PCB BOARD LAYOUT

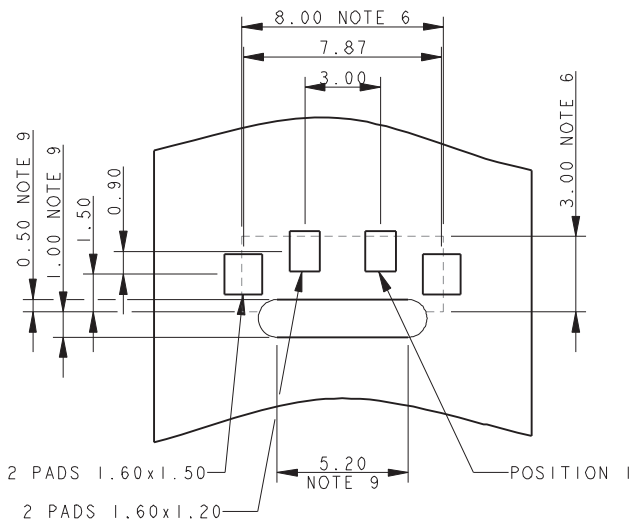

### PACKING DETAILS

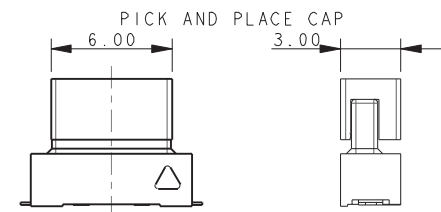

UNREELED DIRECTION

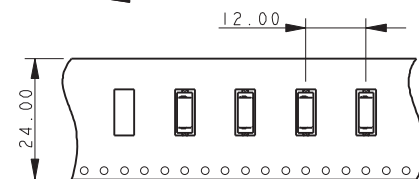

UNREELED DIRECTION

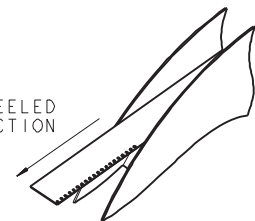

# Vertical SMT Plug



Series 13-9159

## PLUG – VERTICAL MOUNT 3 WAY 2 PART PCB STRIP CONNECTOR

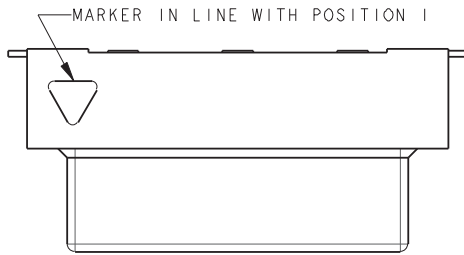

**NOTES:**

1. FOR FULL PRODUCT SPECIFICATION STANDARD CONNECTORS REFER TO ELCO SPEC 201-01-119, UL COMPONENTS REFER TO ELCO SPEC 201-01-119UL. FOR APPLICATION NOTES REFER TO 201-01-123.
2. GENERAL TOLERANCE  $\pm 0.20$  UNLESS TOLERANCED.
3. INSULATOR MATERIAL: NYLON 46, UL94 V-0, COLOR REFER TO PAGE 18.
4. CONTACT MATERIAL: COPPER ALLOY, SELECTIVE GOLD OVER NICKEL, TIN PLATE ON TAILS.
5. BRACKETS: COPPER ALLOY, TIN PLATED.
6. OUTLINE OF CONNECTOR.
7. PACKING IN TAPE AND REEL, QUANTITY PER REEL 700.
8. PICK AND PLACE CAP TO BE REMOVED AFTER USE.
9. OPTIONAL SLOT: ONLY REQUIRED WHEN SOCKET HAS A LATCH, RADIUS ON ENDS OPTIONAL.

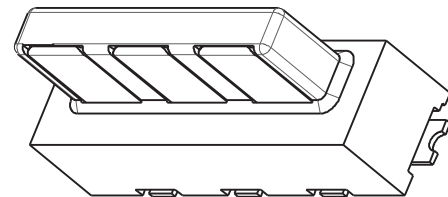
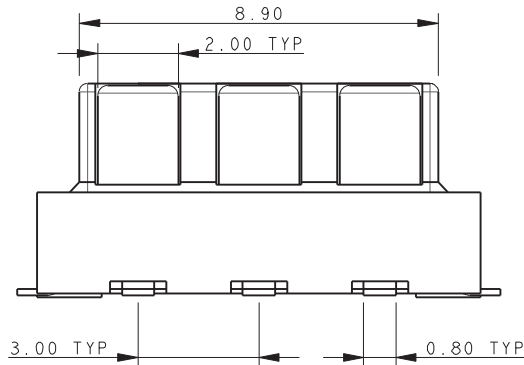
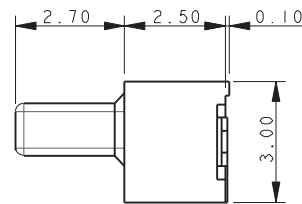
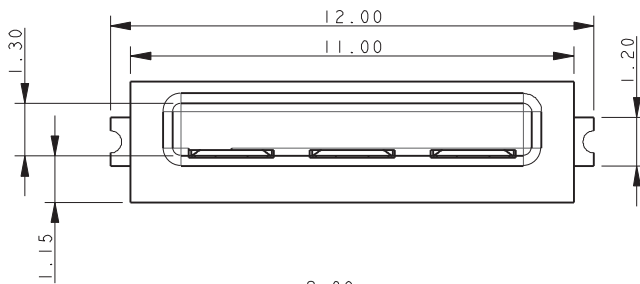

### 3 WAY PCB BOARD LAYOUT

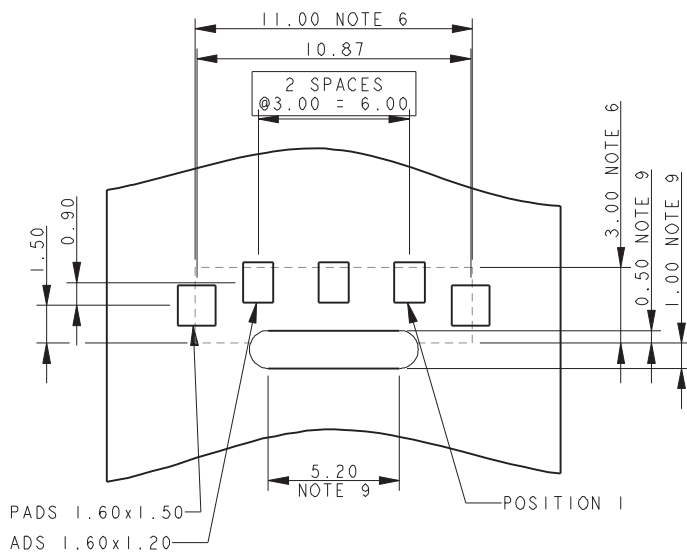

### PACKING DETAILS

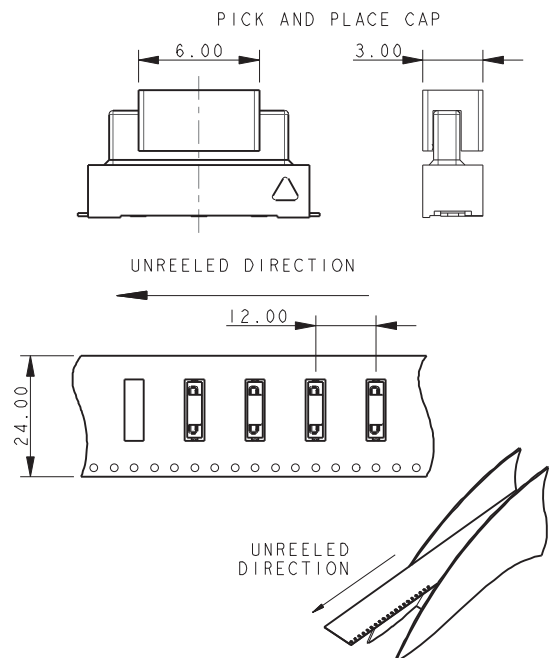

# Vertical SMT Plug



Series 13-9159

## PLUG – VERTICAL MOUNT 4 WAY 2 PART PCB STRIP CONNECTOR

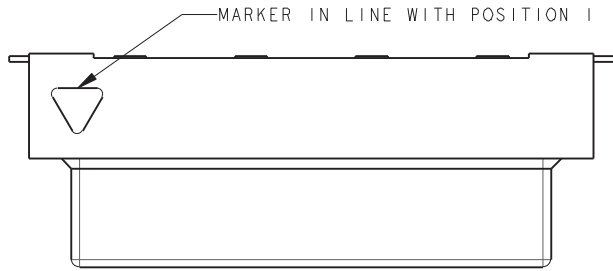

### NOTES:

1. FOR FULL PRODUCT SPECIFICATION STANDARD CONNECTORS REFER TO ELCO SPEC 201-01-119, UL COMPONENTS REFER TO ELCO SPEC 201-01-119UL. FOR APPLICATION NOTES REFER TO 201-01-123.
2. GENERAL TOLERANCE  $\pm 0.20$  UNLESS TOLERANCED.
3. INSULATOR MATERIAL: NYLON 46, UL94 V-0, COLOR REFER TO PAGE 18.
4. CONTACT MATERIAL: COPPER ALLOY, SELECTIVE GOLD OVER NICKEL, TIN PLATE ON TAILS.
5. BRACKETS: COPPER ALLOY, TIN PLATED.
6. OUTLINE OF CONNECTOR.
7. PACKING IN TAPE AND REEL, QUANTITY PER REEL 700.
8. PICK AND PLACE CAP TO BE REMOVED AFTER USE.
9. OPTIONAL SLOT: ONLY REQUIRED WHEN SOCKET HAS A LATCH, RADIUS ON ENDS OPTIONAL.

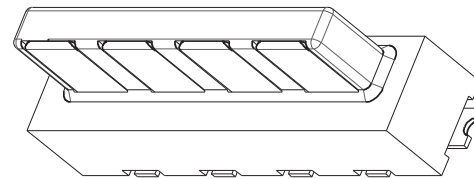
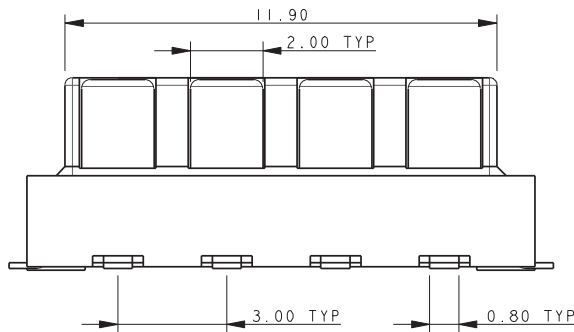
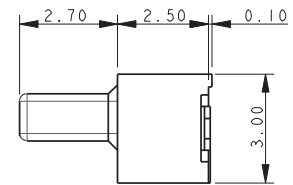
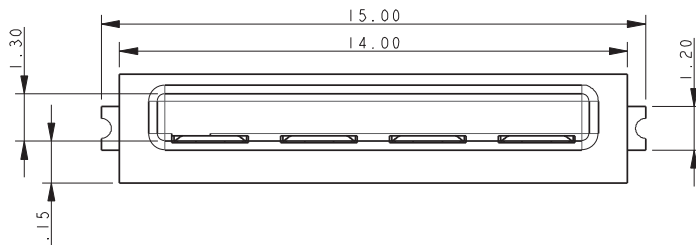

### PACKING DETAILS

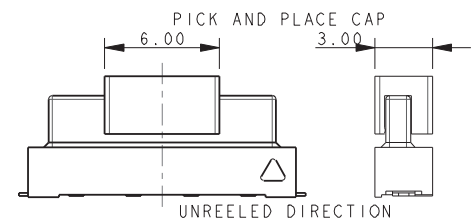

### 4 WAY PCB BOARD LAYOUT

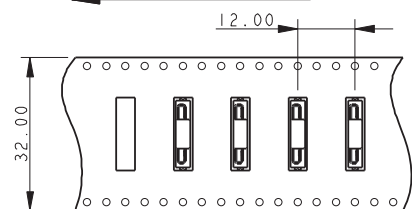
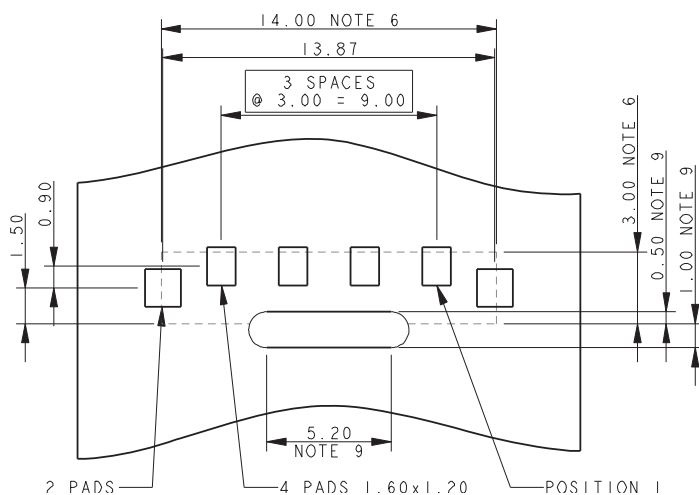

UNREEL DIRECTION



# Vertical SMT Plug



Series 13-9159

## PLUG – VERTICAL MOUNT 5 WAY 2 PART PCB STRIP CONNECTOR

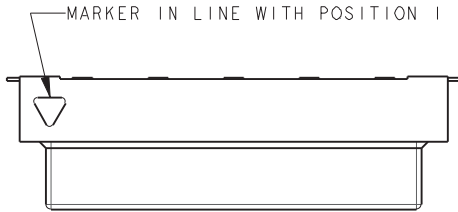

NOTES:

1. FOR FULL PRODUCT SPECIFICATION STANDARD CONNECTORS REFER TO ELCO SPEC 201-01-119, UL COMPONENTS REFER TO ELCO SPEC 201-01-119UL. FOR APPLICATION NOTES REFER TO 201-01-123.
2. GENERAL TOLERANCE  $\pm 0.20$  UNLESS TOLERANCED.
3. INSULATOR MATERIAL: NYLON 46, UL94 V-0, COLOR REFER TO PAGE 18.
4. CONTACT MATERIAL: COPPER ALLOY, SELECTIVE GOLD OVER NICKEL, TIN PLATE ON TAILS.
5. BRACKETS: COPPER ALLOY, TIN PLATED.
6. OUTLINE OF CONNECTOR.
7. PACKING IN TAPE AND REEL, QUANTITY PER REEL 700.
8. PICK AND PLACE CAP TO BE REMOVED AFTER USE.
9. OPTIONAL SLOT: ONLY REQUIRED WHEN SOCKET HAS A LATCH, RADIUS ON ENDS OPTIONAL.

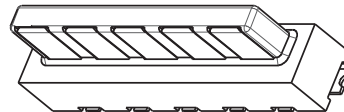
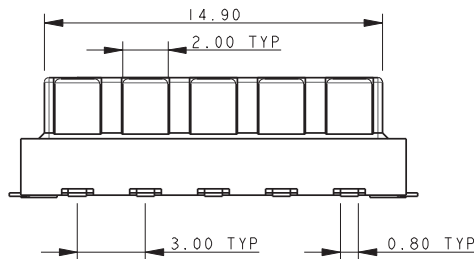
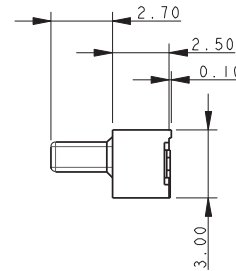
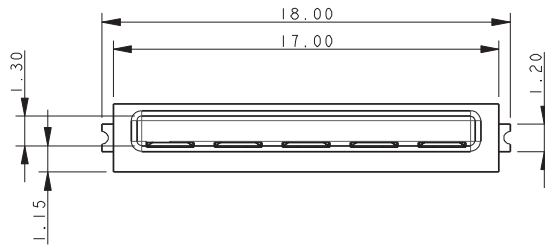

### 5 WAY PCB BOARD LAYOUT

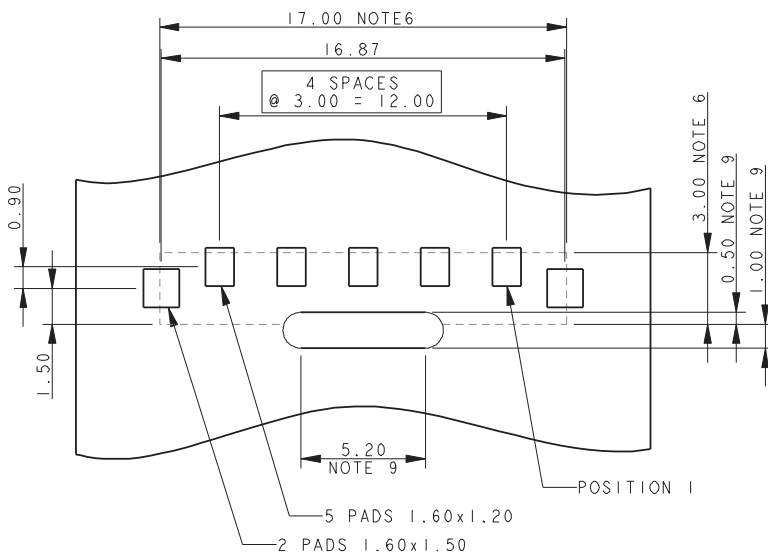

### PACKING DETAILS

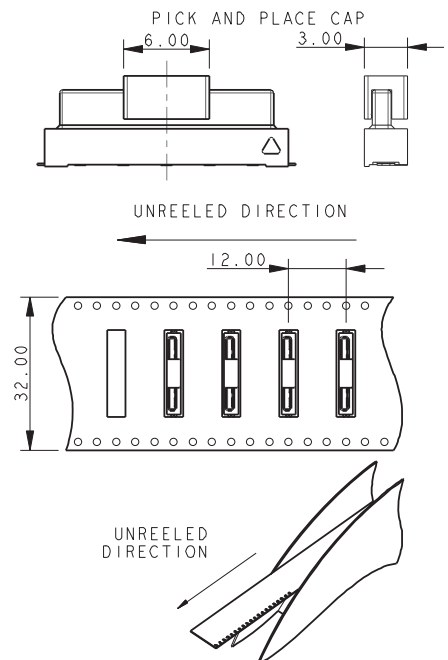



# Vertical SMT Plug



Series 13-9159

## PLUG – VERTICAL MOUNT 6 WAY 2 PART PCB STRIP CONNECTOR

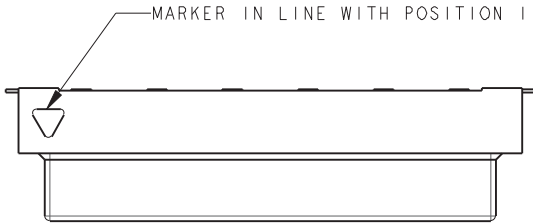

**NOTES:**

1. FOR FULL PRODUCT SPECIFICATION STANDARD CONNECTORS REFER TO ELCO SPEC 201-01-119, UL COMPONENTS REFER TO ELCO SPEC 201-01-119UL. FOR APPLICATION NOTES REFER TO 201-01-123.
2. GENERAL TOLERANCE  $\pm 0.20$  UNLESS TOLERANCED.
3. INSULATOR MATERIAL: NYLON 46, UL94 V-0, COLOR REFER TO PAGE 18.
4. CONTACT MATERIAL: COPPER ALLOY, SELECTIVE GOLD OVER NICKEL, TIN PLATE ON TAILS.
5. BRACKETS: COPPER ALLOY, TIN PLATED.
6. OUTLINE OF CONNECTOR.
7. PACKING IN TAPE AND REEL, QUANTITY PER REEL 700.
8. PICK AND PLACE CAP TO BE REMOVED AFTER USE.
9. OPTIONAL SLOT: ONLY REQUIRED WHEN SOCKET HAS A LATCH, RADIUS ON ENDS OPTIONAL.

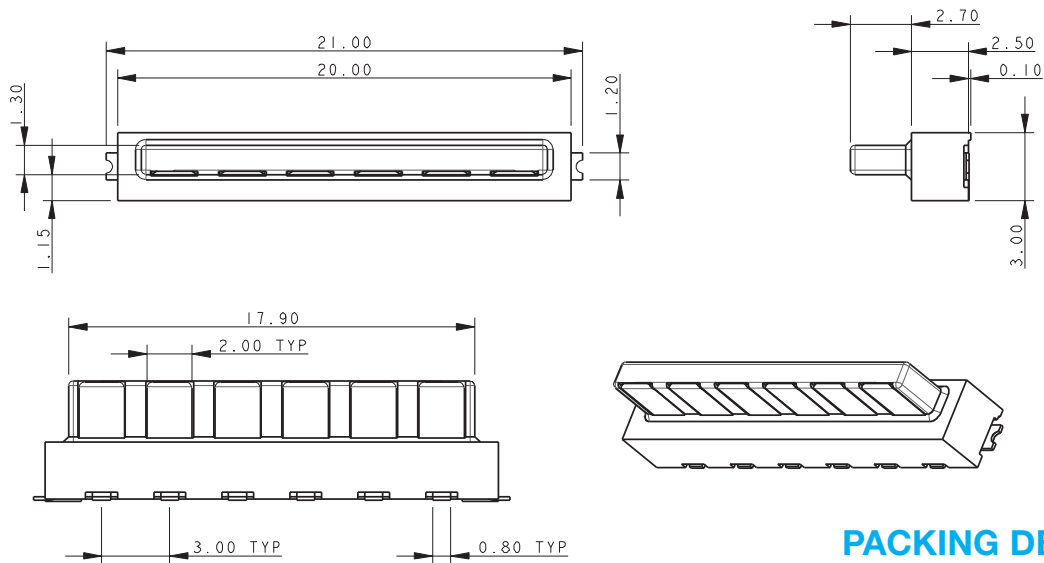

### 6 WAY PCB BOARD LAYOUT

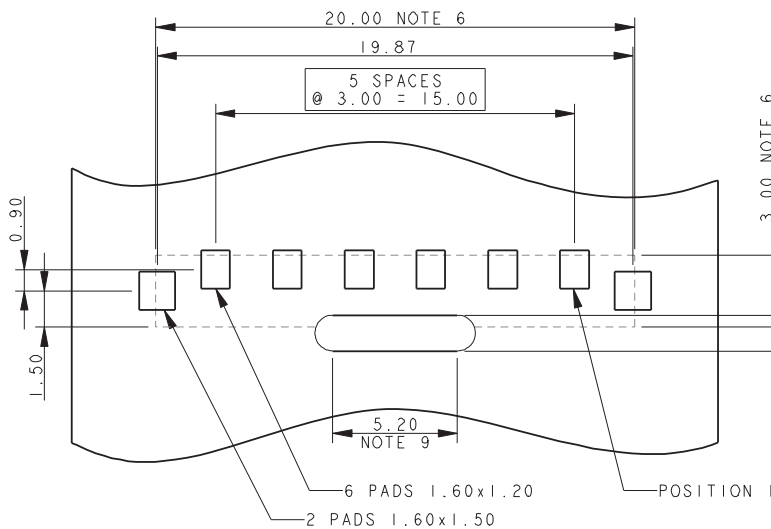

### PACKING DETAILS

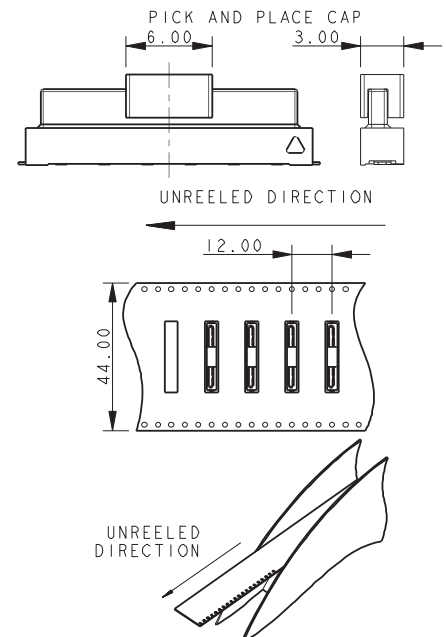



# IDC Plug: WTB Through Wire Cap/Wire Stop Cap

## Series 14-9159



AVX developed the 9159 Series of SMT connectors for co-planar PCB mating for the challenging Solid State Lighting (SSL) market. These connectors needed to be small, low in height, carry up to 5 Amps/contact and then function up to 125C for extended periods. This application has been very unique to the SSL market where PCB's are stacked end-to-end to create linear strip lighting in everything from office to transportation applications where products are exposed to harsh mechanical and environmental environments.

The IDC cable plug connector allows for 22-24AWG discrete or cabled wires to be easily and reliability terminated into a 9159 standard interface socket connector. This will allow power and signals to be connectors onto a PCB socket connector while providing positive latching. The wire assembly support block allows for 2 through 6 wires to be terminated all in one step with any standard bench top press. IDC covers provide both through (daisy chain applications) and wire stop termination options.

### APPLICATIONS

- Provides Wire-to-Board capabilities to standard 9159 2-Piece connector system
- In conjunction with the IDC socket WTB connector (24-9159), these connectors provide maximum flexibility to bring power and signal wires onto or off of any board level 9159 connector
- Reference application notes 201-01-123
- Reference Product Specification 201-01-119

### FEATURES AND BENEFITS

- Mates with standard 9159 horizontal socket, keeping same BTB connector system
- Economical and reliable IDC wire termination
- Gold plated BeCu contact system for high reliability in harsh environments
- Integrally molded latch offers positive latching after mating

### ELECTRICAL

- Current Rating: 5 Amps / Contact
- Voltage Rating: 125 VAC

### ENVIRONMENTAL

- Operating Temperature: -40°C to +125°C

### MECHANICAL

- Insulator Material: Nylon: UL94V0
- Contact Material: Phosphor Bronze
- Plating: Gold / Tin over Nickel
- Durability: 10 Cycles

### HOW TO ORDER

<b>14</b>	<b>9159</b>	<b>XXX</b>	<b>1</b>	<b>X</b>	<b>2</b>	<b>9</b>	<b>X</b>	<b>6</b>																																																			
Prefix	Series	Number of Ways	2 Part PCB Strip Connector	Wire Gauge	Wire Insulation Diameter	Color Options	Cap Options	Plating Option																																																			
Right Angle Wired Plug IDC Terminations			2 Part Wired IDC Strip Connector	2 = 22AWG 3 = 24AWG	ø1.10mm to ø1.60mm	9 = UL 1 = White																																																					
		<table border="1"> <thead> <tr> <th>Code</th> <th>No of Ways</th> <th>Details</th> </tr> </thead> <tbody> <tr> <td colspan="3">THROUGH WIRE CAP</td> </tr> <tr> <td>002</td> <td>2</td> <td>Page 25</td> </tr> <tr> <td>003</td> <td>3</td> <td>Page 26</td> </tr> <tr> <td>004</td> <td>4</td> <td>Page 27</td> </tr> <tr> <td>005</td> <td>5</td> <td>Page 28</td> </tr> <tr> <td>006</td> <td>6</td> <td>Page 29</td> </tr> <tr> <td colspan="3">WIRE STOP CAP</td> </tr> <tr> <td>002</td> <td>2</td> <td>Page 30</td> </tr> <tr> <td>003</td> <td>3</td> <td>Page 31</td> </tr> <tr> <td>004</td> <td>4</td> <td>Page 32</td> </tr> <tr> <td>005</td> <td>5</td> <td>Page 33</td> </tr> <tr> <td>006</td> <td>6</td> <td>Page 34</td> </tr> </tbody> </table>	Code	No of Ways	Details	THROUGH WIRE CAP			002	2	Page 25	003	3	Page 26	004	4	Page 27	005	5	Page 28	006	6	Page 29	WIRE STOP CAP			002	2	Page 30	003	3	Page 31	004	4	Page 32	005	5	Page 33	006	6	Page 34				<table border="1"> <thead> <tr> <th>Code</th> <th>Cap Option</th> <th>Description</th> </tr> </thead> <tbody> <tr> <td>0</td> <td>Through Wire</td> <td>Allows wires to be terminated at any point</td> </tr> <tr> <td>9</td> <td>Wire Stop</td> <td>Terminates end of wire. End protected with Stop Face</td> </tr> </tbody> </table>	Code	Cap Option	Description	0	Through Wire	Allows wires to be terminated at any point	9	Wire Stop	Terminates end of wire. End protected with Stop Face	<table border="1"> <thead> <tr> <th>Code</th> <th>Contact</th> </tr> </thead> <tbody> <tr> <td>6</td> <td>Gold on Contact Tin on IDC</td> </tr> </tbody> </table>	Code	Contact	6	Gold on Contact Tin on IDC
Code	No of Ways	Details																																																									
THROUGH WIRE CAP																																																											
002	2	Page 25																																																									
003	3	Page 26																																																									
004	4	Page 27																																																									
005	5	Page 28																																																									
006	6	Page 29																																																									
WIRE STOP CAP																																																											
002	2	Page 30																																																									
003	3	Page 31																																																									
004	4	Page 32																																																									
005	5	Page 33																																																									
006	6	Page 34																																																									
Code	Cap Option	Description																																																									
0	Through Wire	Allows wires to be terminated at any point																																																									
9	Wire Stop	Terminates end of wire. End protected with Stop Face																																																									
Code	Contact																																																										
6	Gold on Contact Tin on IDC																																																										



Certification: UL File #E90723



# IDC Plug: WTB Through Wire Cap/Wire Stop Cap



Series 14-9159

## PLUG-WIRED – 2 WAY THROUGH WIRE CAP

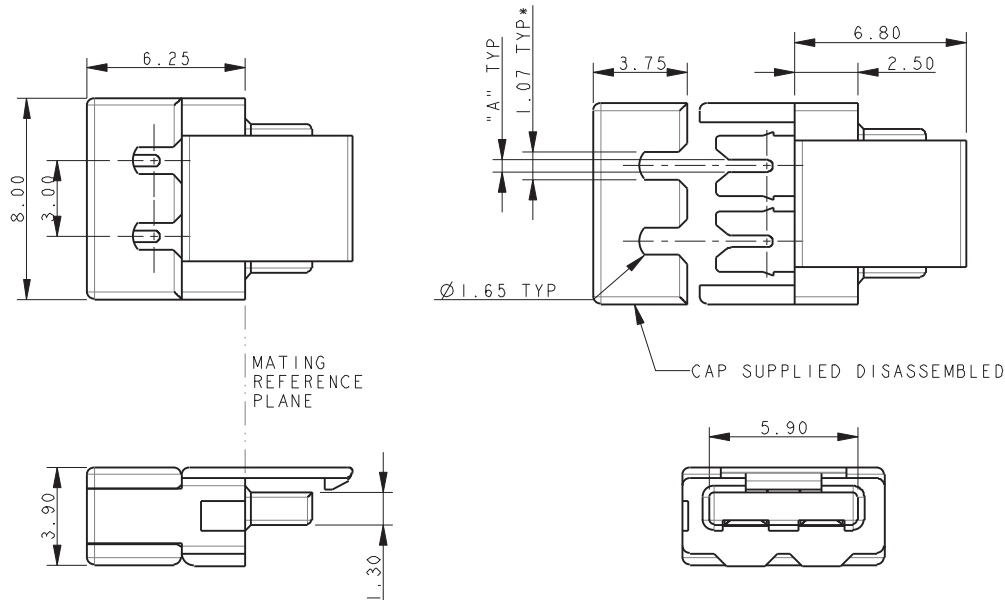

**NOTES:**

1. FOR MORE INFORMATION REFER TO PRODUCT SPEC 201-01-119.  
FOR WIRE ASSEMBLY REFER TO APPLICATION NOTES 201-01-123.
2. THROUGH WIRE CAP, FOR TERMINATION OF WIRE IN ANY POSITION.
3. CAP ACTS AS WIRE ASSEMBLY TOOL. WIRE PREFIT TO CAP, NARROW SLOT TO GRIP WIRE, PERMANENT ASSEMBLY.
4. GENERAL TOLERANCE  $\pm 0.20$  UNLESS SPECIFIED.
5. INSULATOR MATERIAL: NYLON 46, GLASS FILLED, UL94 V-0. COLOR REFER TO PAGE 24.
6. CONTACT MATERIAL: COPPER ALLOY, PLATING NICKEL BASE ALL OVER, GOLD ON CONTACT, TIN ON IDC.
7. PACKING IN TAPE AND REEL. QTY PER REEL 700, POCKET CONTAINS 1 CONNECTOR AND 1 CAP.
8. WIRE GAUGE OPTIONS, SEE TABLE.
9. ASSEMBLY AIDS, REFER TO PAGE 35.

Wire Gauge	Code (Page 24)	Dimension A	Wire Insulation Diameter
22AWG (Stranded Wire)	122	0.47	1.10 to 1.60
24AWG (Stranded Wire)	132	0.37	1.10 to 1.60

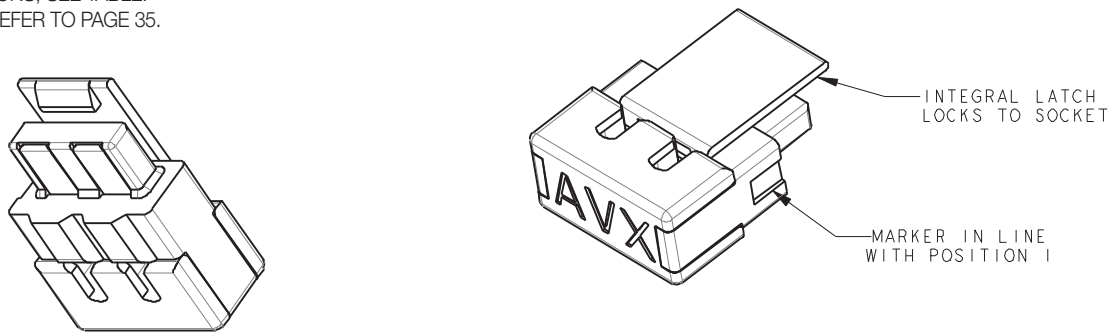

## PACKING DETAILS CAP AND CONNECTOR SUPPLIED TOGETHER (2 PARTS)

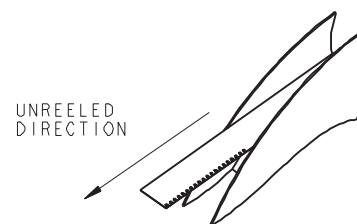
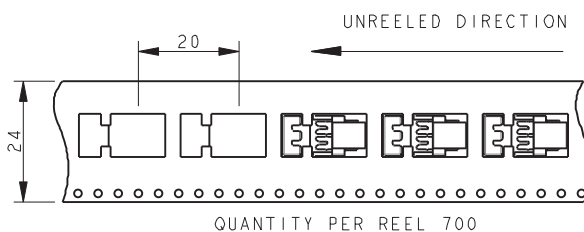

# IDC Plug: WTB Through Wire Cap/Wire Stop Cap



Series 14-9159

## PLUG-WIRED – 3 WAY THROUGH WIRE CAP

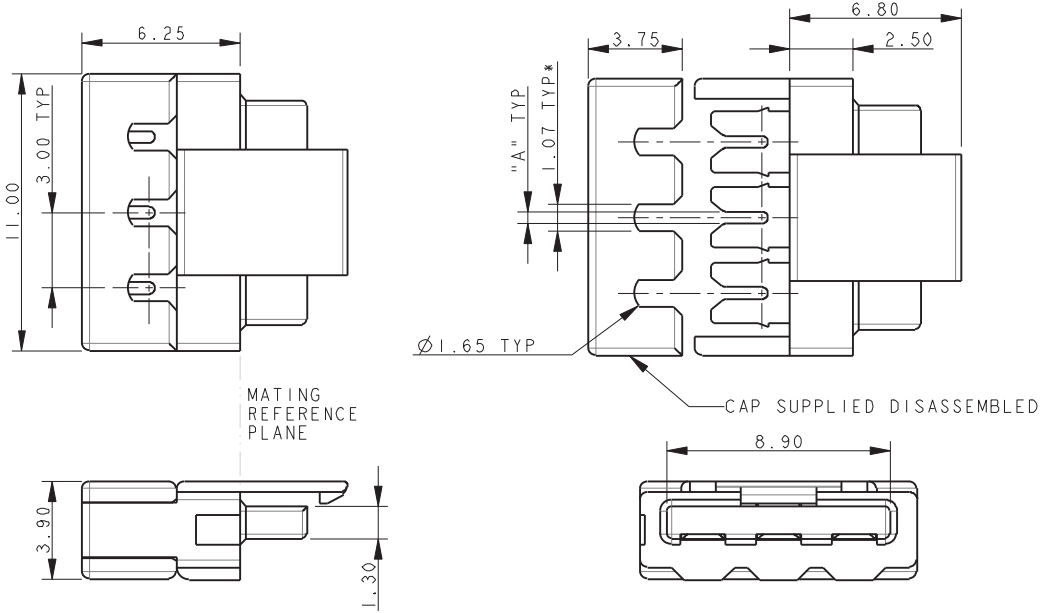

**NOTES:**

1. FOR MORE INFORMATION REFER TO PRODUCT SPEC 201-01-119.  
FOR WIRE ASSEMBLY REFER TO APPLICATION NOTES 201-01-123.
2. THROUGH WIRE CAP, FOR TERMINATION OF WIRE IN ANY POSITION.
3. CAP ACTS AS WIRE ASSEMBLY TOOL. WIRE PREFIT TO CAP, NARROW SLOT TO GRIP WIRE, PERMANENT ASSEMBLY.
4. GENERAL TOLERANCE ±0.20 UNLESS SPECIFIED.
5. INSULATOR MATERIAL: NYLON 46, GLASS FILLED, UL94 V-0. COLOR REFER TO PAGE 24.
6. CONTACT MATERIAL: COPPER ALLOY, PLATING NICKEL BASE ALL OVER, GOLD ON CONTACT, TIN ON IDC.
7. PACKING IN TAPE AND REEL. QTY PER REEL 700, POCKET CONTAINS 1 CONNECTOR AND 1 CAP.
8. WIRE GAUGE OPTIONS, SEE TABLE.
9. ASSEMBLY AIDS, REFER TO PAGE 35.

Wire Gauge	Code (Page 24)	Dimension A	Wire Insulation Diameter
22AWG (Stranded Wire)	122	0.47	1.10 to 1.60
24AWG (Stranded Wire)	132	0.37	1.10 to 1.60

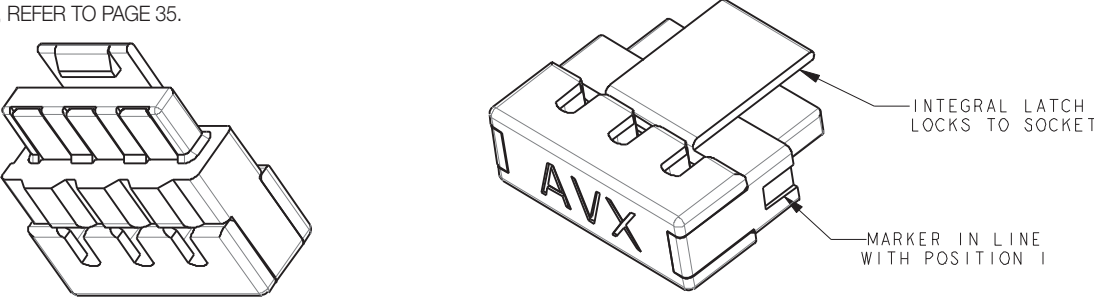

## PACKING DETAILS CAP AND CONNECTOR SUPPLIED TOGETHER (2 PARTS)

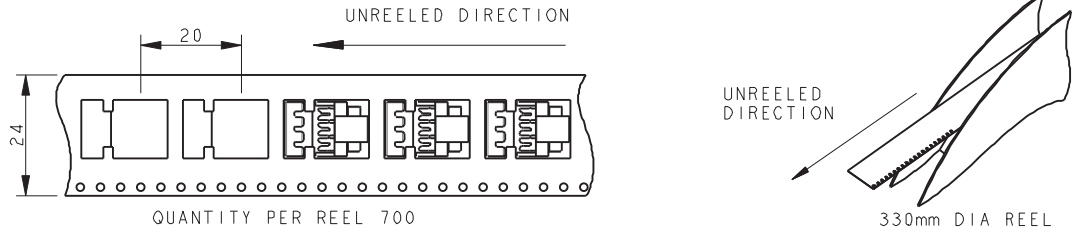

# IDC Plug: WTB Through Wire Cap/Wire Stop Cap



Series 14-9159

## PLUG-WIRED – 4 WAY THROUGH WIRE CAP

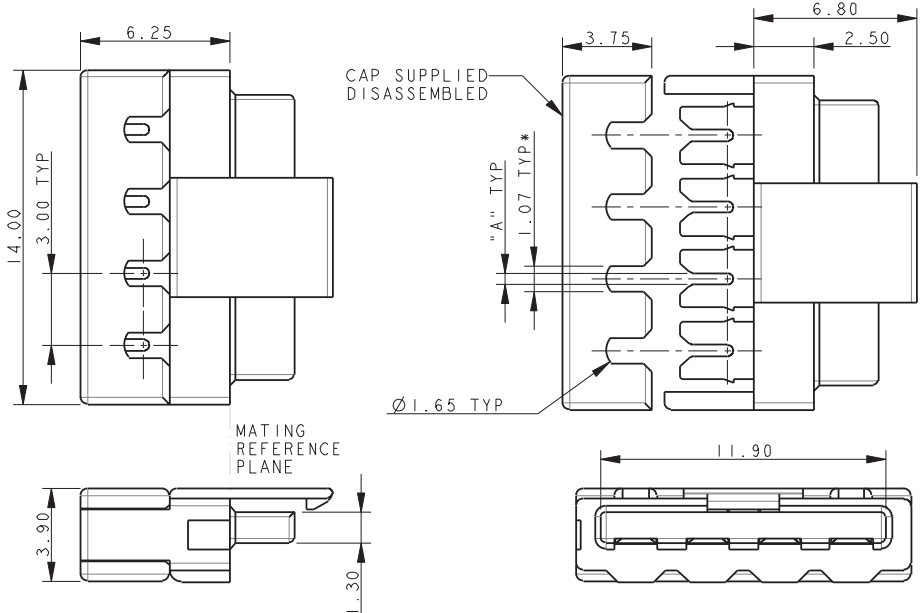

**NOTES:**

1. FOR MORE INFORMATION REFER TO PRODUCT SPEC 201-01-119.  
FOR WIRE ASSEMBLY REFER TO APPLICATION NOTES 201-01-123.
2. THROUGH WIRE CAP, FOR TERMINATION OF WIRE IN ANY POSITION.
3. CAP ACTS AS WIRE ASSEMBLY TOOL. WIRE PREFIT TO CAP, NARROW SLOT TO GRIP WIRE, PERMANENT ASSEMBLY.
4. GENERAL TOLERANCE  $\pm 0.20$  UNLESS SPECIFIED.
5. INSULATOR MATERIAL: NYLON 46, GLASS FILLED, UL94 V-0. COLOR REFER TO PAGE 24.
6. CONTACT MATERIAL: COPPER ALLOY, PLATING NICKEL BASE ALL OVER, GOLD ON CONTACT, TIN ON IDC.
7. PACKING IN TAPE AND REEL. QTY PER REEL 700, POCKET CONTAINS 1 CONNECTOR AND 1 CAP.
8. WIRE GAUGE OPTIONS, SEE TABLE.
9. ASSEMBLY AIDS, REFER TO PAGE 35.

Wire Gauge	Code (Page 24)	Dimension A	Wire Insulation Diameter
22AWG (Stranded Wire)	122	0.47	1.10 to 1.60
24AWG (Stranded Wire)	132	0.37	1.10 to 1.60

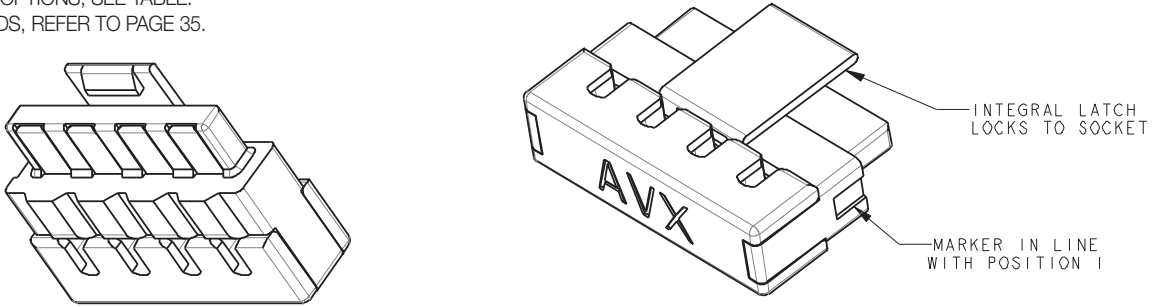

## PACKING DETAILS CAP AND CONNECTOR SUPPLIED TOGETHER (2 PARTS)

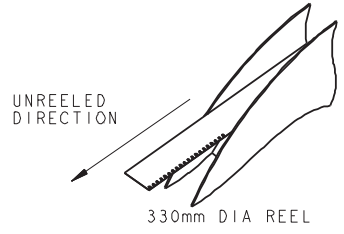
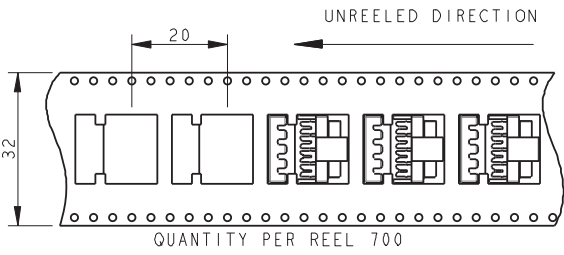

# IDC Plug: WTB

# Through Wire Cap/Wire Stop Cap

Series 14-9159



## PLUG-WIRED – 5 WAY THROUGH WIRE CAP

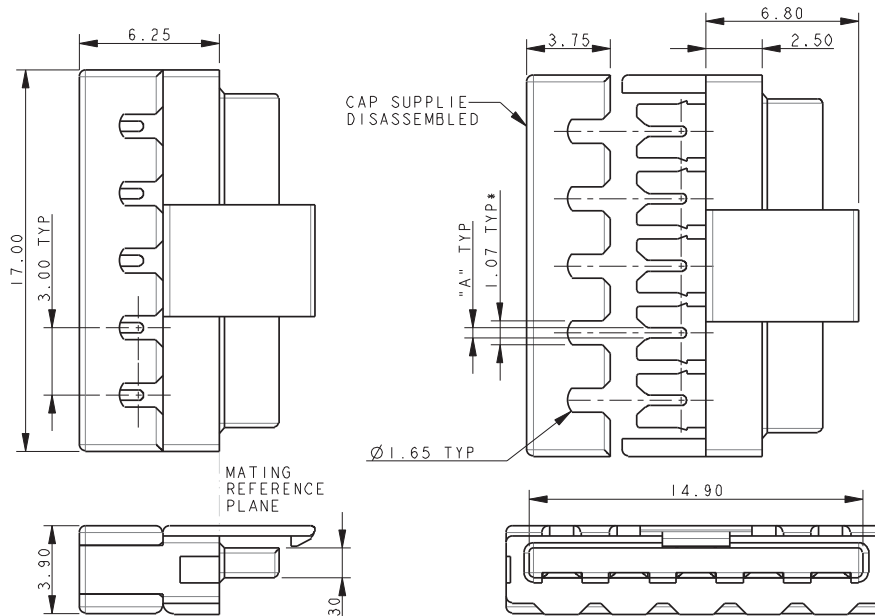

**NOTES:**

1. FOR MORE INFORMATION REFER TO PRODUCT SPEC 201-01-119.  
FOR WIRE ASSEMBLY REFER TO APPLICATION NOTES 201-01-123.
2. THROUGH WIRE CAP, FOR TERMINATION OF WIRE IN ANY POSITION.
3. CAP ACTS AS WIRE ASSEMBLY TOOL. WIRE PREFIT TO CAP, NARROW SLOT TO GRIP WIRE, PERMANENT ASSEMBLY.
4. GENERAL TOLERANCE  $\pm 0.20$  UNLESS SPECIFIED.
5. INSULATOR MATERIAL: NYLON 46, GLASS FILLED, UL94 V-0. COLOR REFER TO PAGE 24.
6. CONTACT MATERIAL: COPPER ALLOY, PLATING NICKEL BASE ALL OVER, GOLD ON CONTACT, TIN ON IDC.
7. PACKING IN TAPE AND REEL. QTY PER REEL 700, POCKET CONTAINS 1 CONNECTOR AND 1 CAP.
8. WIRE GAUGE OPTIONS, SEE TABLE.
9. ASSEMBLY AIDS, REFER TO PAGE 35.

Wire Gauge	Code (Page 24)	Dimension A	Wire Insulation Diameter
22AWG (Stranded Wire)	122	0.47	1.10 to 1.60
24AWG (Stranded Wire)	132	0.37	1.10 to 1.60

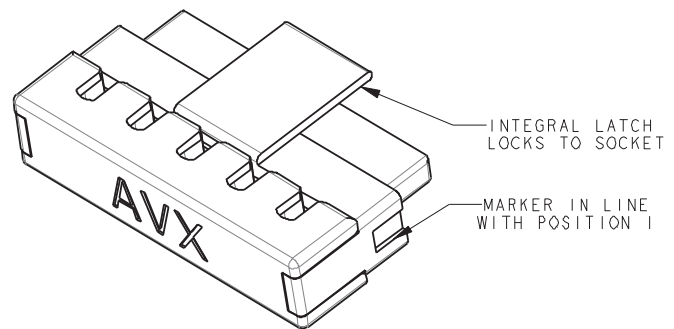
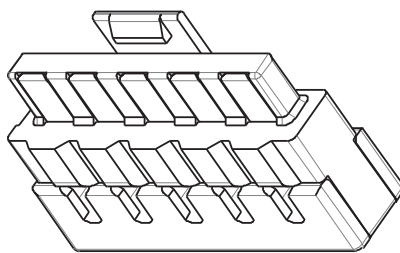

## PACKING DETAILS CAP AND CONNECTOR SUPPLIED TOGETHER (2 PARTS)

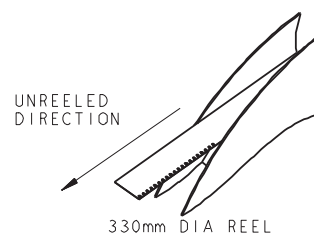
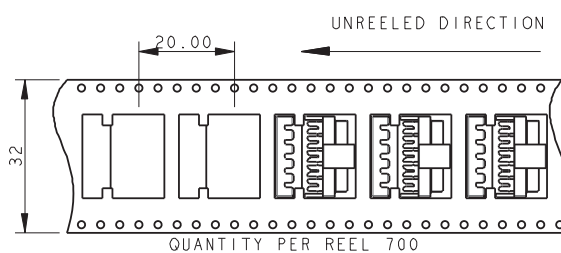

# IDC Plug: WTB



## Through Wire Cap/Wire Stop Cap

Series 14-9159

### PLUG-WIRED – 6 WAY THROUGH WIRE CAP

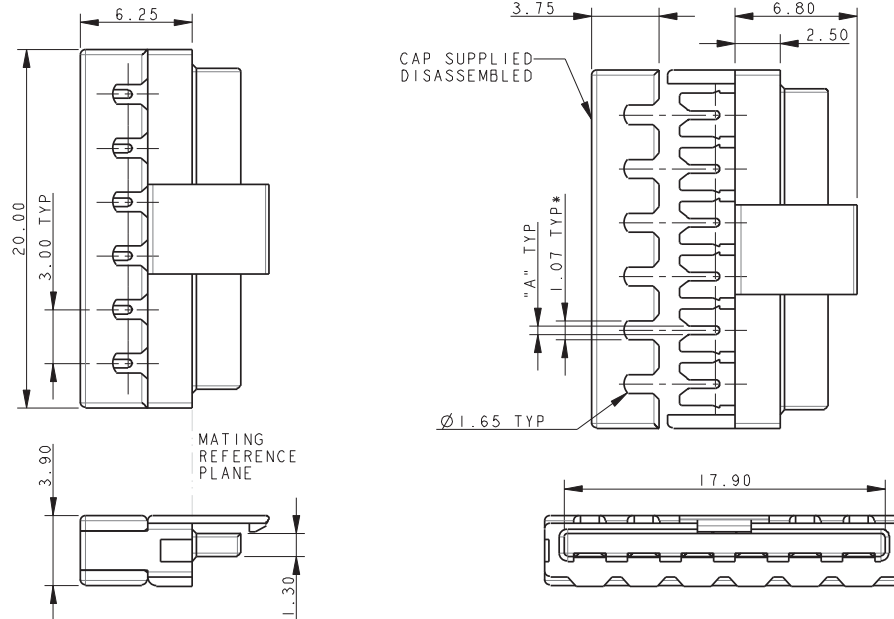

**NOTES:**

1. FOR MORE INFORMATION REFER TO PRODUCT SPEC 201-01-119.  
FOR WIRE ASSEMBLY REFER TO APPLICATION NOTES 201-01-123.
2. THROUGH WIRE CAP, FOR TERMINATION OF WIRE IN ANY POSITION.
3. CAP ACTS AS WIRE ASSEMBLY TOOL. WIRE PREFIT TO CAP, NARROW SLOT TO GRIP WIRE, PERMANENT ASSEMBLY.
4. GENERAL TOLERANCE  $\pm 0.20$  UNLESS SPECIFIED.
5. INSULATOR MATERIAL: NYLON 46, GLASS FILLED, UL94 V-0. COLOR REFER TO PAGE 24.
6. CONTACT MATERIAL: COPPER ALLOY, PLATING NICKEL BASE ALL OVER, GOLD ON CONTACT, TIN ON IDC.
7. PACKING IN TAPE AND REEL. QTY PER REEL 700, POCKET CONTAINS 1 CONNECTOR AND 1 CAP.
8. WIRE GAUGE OPTIONS, SEE TABLE.
9. ASSEMBLY AIDS, REFER TO PAGE 35.

Wire Gauge	Code (Page 24)	Dimension A	Wire Insulation Diameter
22AWG (Stranded Wire)	122	0.47	1.10 to 1.60
24AWG (Stranded Wire)	132	0.37	1.10 to 1.60

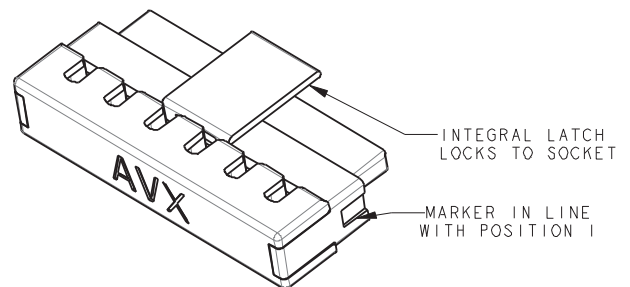
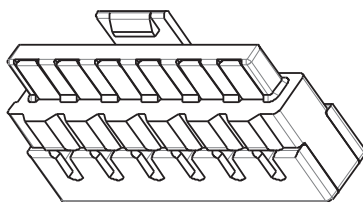

### PACKING DETAILS CAP AND CONNECTOR SUPPLIED TOGETHER (2 PARTS)

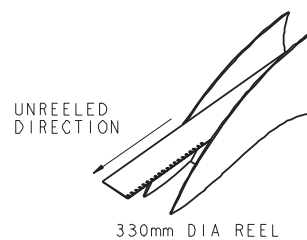
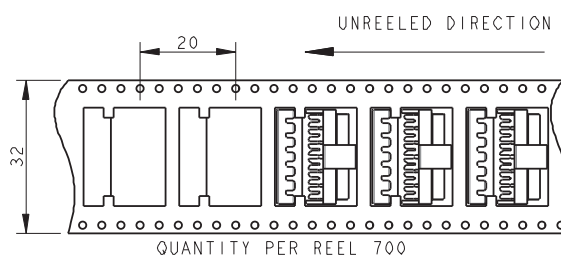

# IDC Plug: WTB Through Wire Cap/Wire Stop Cap



Series 14-9159

## PLUG-WIRED – 2 WAY WIRE STOP CAP

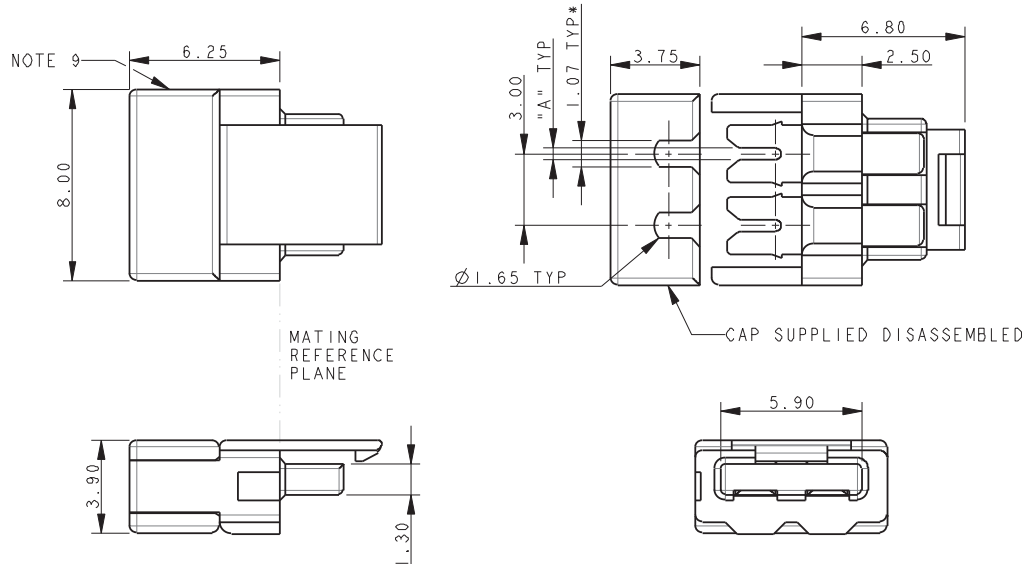

**NOTES:**

1. FOR MORE INFORMATION REFER TO PRODUCT SPEC 201-01-119. FOR WIRE ASSEMBLY REFER TO APPLICATION NOTES 201-01-123.
2. WIRE STOP CAP, WITH STOP FACE ON ONE SIDE TO PROTECT END OF WIRE.
3. CAP ACTS AS WIRE ASSEMBLY TOOL. WIRE PREFIT TO CAP, NARROW SLOT TO GRIP WIRE, PERMANENT ASSEMBLY.
4. GENERAL TOLERANCE  $\pm 0.20$  UNLESS SPECIFIED.
5. INSULATOR MATERIAL: NYLON 46, GLASS FILLED, UL94 V-0. COLOR REFER TO PAGE 24.
6. CONTACT MATERIAL: COPPER ALLOY, PLATING NICKEL BASE ALL OVER, GOLD ON CONTACT, TIN ON IDC.
7. PACKING IN TAPE AND REEL. QTY PER REEL 700, POCKET CONTAINS 1 CONNECTOR AND 1 CAP.
8. WIRE GAUGE OPTIONS, SEE TABLE.
9. SHOWN WITH WIRE ENTRY FROM UNDERSIDE, CAP CAN BE ASSEMBLED FOR EITHER TOP OR UNDERSIDE WIRE ENTRY.
10. ASSEMBLY AIDS, REFER TO PAGE 35.

Wire Gauge	Code (Page 24)	Dimension A	Wire Insulation Diameter
22AWG (Stranded Wire)	122	0.47	1.10 to 1.60
24AWG (Stranded Wire)	132	0.37	1.10 to 1.60

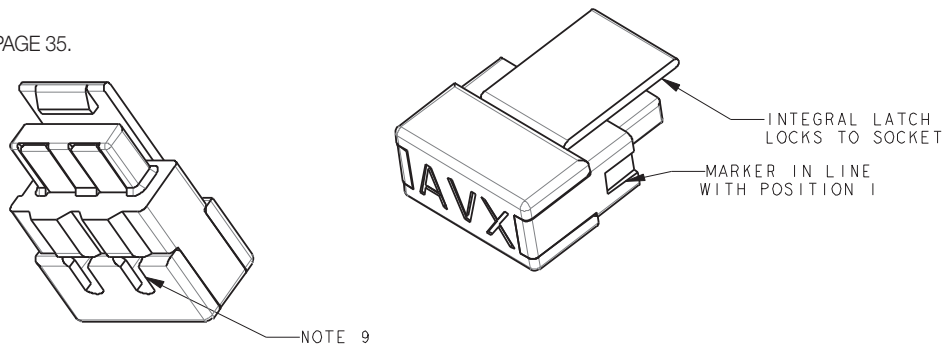

## PACKING DETAILS CAP AND CONNECTOR SUPPLIED TOGETHER (2 PARTS)

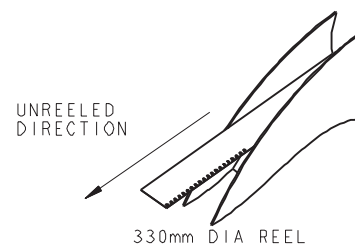
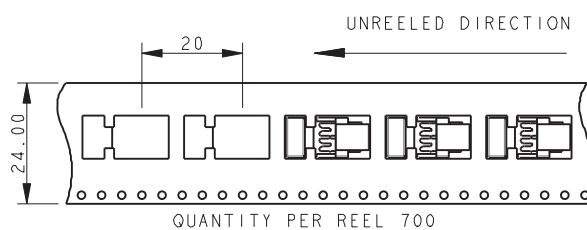



# IDC Plug: WTB



# Through Wire Cap/Wire Stop Cap

Series 14-9159

## PLUG-WIRED – 3 WAY WIRE STOP CAP

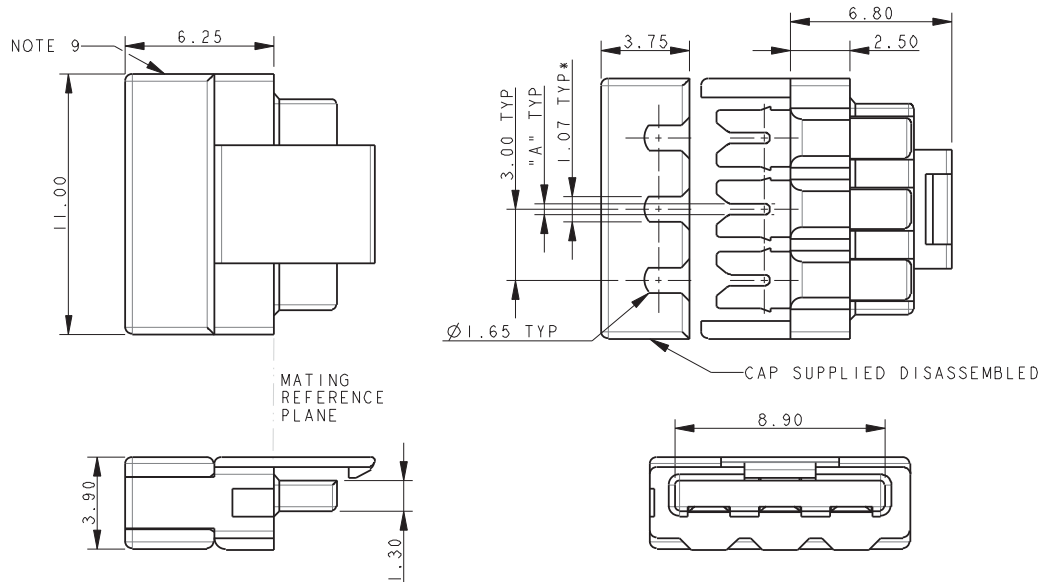

**NOTES:**

1. FOR MORE INFORMATION REFER TO PRODUCT SPEC 201-01-119. FOR WIRE ASSEMBLY REFER TO APPLICATION NOTES 201-01-123.
2. WIRE STOP CAP, WITH STOP FACE ON ONE SIDE TO PROTECT END OF WIRE.
3. CAP ACTS AS WIRE ASSEMBLY TOOL. WIRE PREFIT TO CAP, NARROW SLOT TO GRIP WIRE, PERMANENT ASSEMBLY.
4. GENERAL TOLERANCE  $\pm 0.20$  UNLESS SPECIFIED.
5. INSULATOR MATERIAL: NYLON 46, GLASS FILLED, UL94 V-0. COLOR REFER TO PAGE 24.
6. CONTACT MATERIAL: COPPER ALLOY, PLATING NICKEL BASE ALL OVER, GOLD ON CONTACT, TIN ON IDC.
7. PACKING IN TAPE AND REEL. QTY PER REEL 700, POCKET CONTAINS 1 CONNECTOR AND 1 CAP.
8. WIRE GAUGE OPTIONS, SEE TABLE.
9. SHOWN WITH WIRE ENTRY FROM UNDERSIDE, CAP CAN BE ASSEMBLED FOR EITHER TOP OR UNDERSIDE WIRE ENTRY.
10. ASSEMBLY AIDS, REFER TO PAGE 35.

Wire Gauge	Code (Page 24)	Dimension A	Wire Insulation Diameter
22AWG (Stranded Wire)	122	0.47	1.10 to 1.60
24AWG (Stranded Wire)	132	0.37	1.10 to 1.60

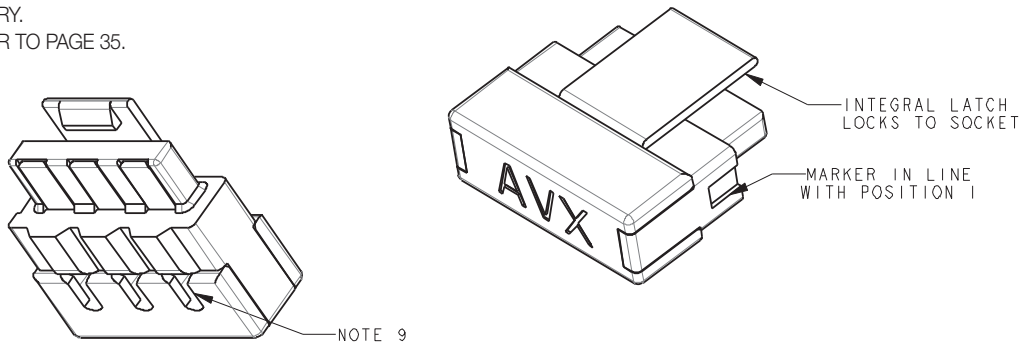

## PACKING DETAILS CAP AND CONNECTOR SUPPLIED TOGETHER (2 PARTS)

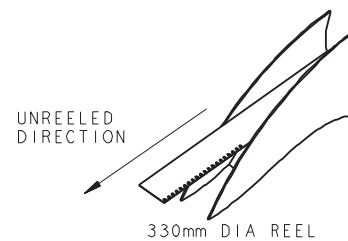
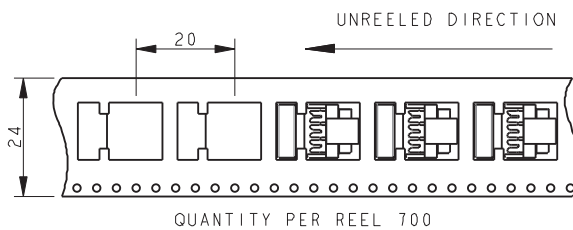

# IDC Plug: WTB



# Through Wire Cap/Wire Stop Cap

Series 14-9159

## PLUG-WIRED – 4 WAY WIRE STOP CAP

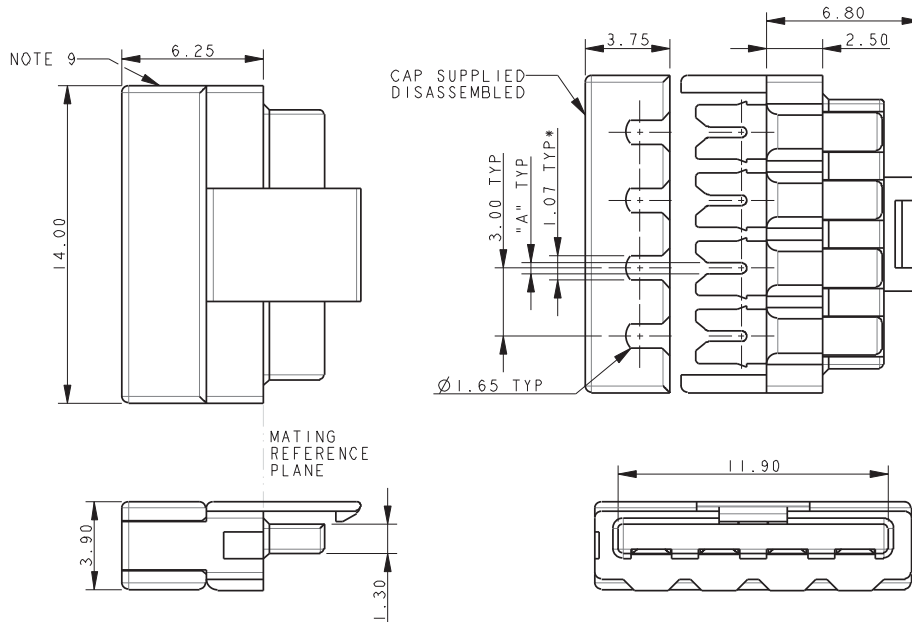

**NOTES:**

1. FOR MORE INFORMATION REFER TO PRODUCT SPEC 201-01-119. FOR WIRE ASSEMBLY REFER TO APPLICATION NOTES 201-01-123.
2. WIRE STOP CAP, WITH STOP FACE ON ONE SIDE TO PROTECT END OF WIRE.
3. CAP ACTS AS WIRE ASSEMBLY TOOL. WIRE PREFIT TO CAP, NARROW SLOT TO GRIP WIRE, PERMANENT ASSEMBLY.
4. GENERAL TOLERANCE  $\pm 0.20$  UNLESS SPECIFIED.
5. INSULATOR MATERIAL: NYLON 46, GLASS FILLED, UL94 V-0. COLOR REFER TO PAGE 24.
6. CONTACT MATERIAL: COPPER ALLOY, PLATING NICKEL BASE ALL OVER, GOLD ON CONTACT, TIN ON IDC.
7. PACKING IN TAPE AND REEL. QTY PER REEL 700, POCKET CONTAINS 1 CONNECTOR AND 1 CAP.
8. WIRE GAUGE OPTIONS, SEE TABLE.
9. SHOWN WITH WIRE ENTRY FROM UNDERSIDE, CAP CAN BE ASSEMBLED FOR EITHER TOP OR UNDERSIDE WIRE ENTRY.
10. ASSEMBLY AIDS, REFER TO PAGE 35.

Wire Gauge	Code (Page 24)	Dimension A	Wire Insulation Diameter
22AWG (Stranded Wire)	122	0.47	1.10 to 1.60
24AWG (Stranded Wire)	132	0.37	1.10 to 1.60

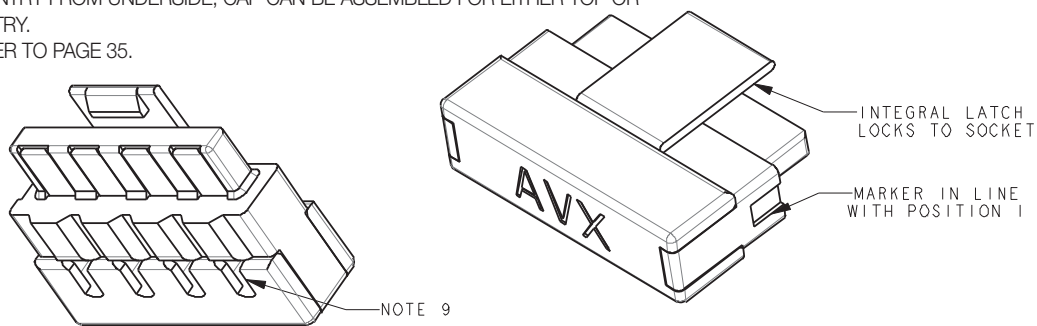

## PACKING DETAILS CAP AND CONNECTOR SUPPLIED TOGETHER (2 PARTS)

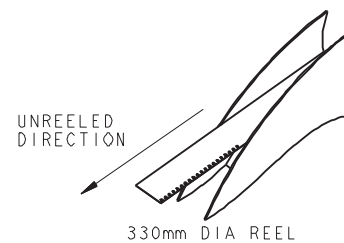
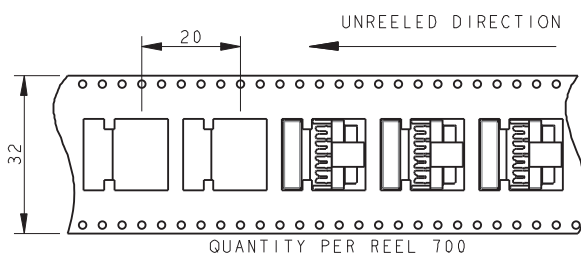

# IDC Plug: WTB Through Wire Cap/Wire Stop Cap



Series 14-9159

## PLUG-WIRED – 5 WAY WIRE STOP CAP

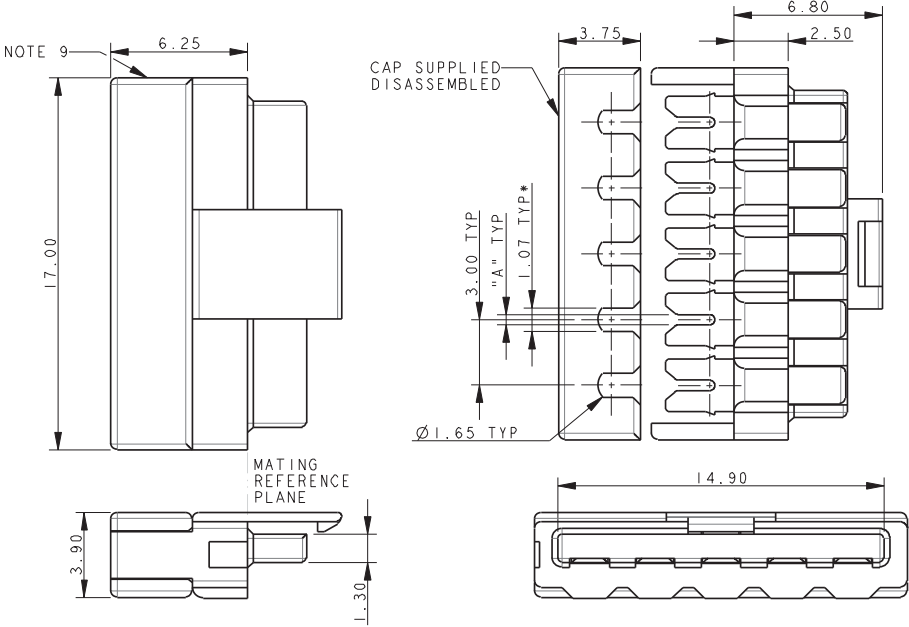

**NOTES:**

1. FOR MORE INFORMATION REFER TO PRODUCT SPEC 201-01-119. FOR WIRE ASSEMBLY REFER TO APPLICATION NOTES 201-01-123.
2. WIRE STOP CAP, WITH STOP FACE ON ONE SIDE TO PROTECT END OF WIRE.
3. CAP ACTS AS WIRE ASSEMBLY TOOL. WIRE PREFIT TO CAP, NARROW SLOT TO GRIP WIRE, PERMANENT ASSEMBLY.
4. GENERAL TOLERANCE  $\pm 0.20$  UNLESS SPECIFIED.
5. INSULATOR MATERIAL: NYLON 46, GLASS FILLED, UL94 V-0. COLOR REFER TO PAGE 24.
6. CONTACT MATERIAL: COPPER ALLOY, PLATING NICKEL BASE ALL OVER, GOLD ON CONTACT, TIN ON IDC.
7. PACKING IN TAPE AND REEL. QTY PER REEL 700, POCKET CONTAINS 1 CONNECTOR AND 1 CAP.
8. WIRE GAUGE OPTIONS, SEE TABLE.
9. SHOWN WITH WIRE ENTRY FROM UNDERSIDE, CAP CAN BE ASSEMBLED FOR EITHER TOP OR UNDERSIDE WIRE ENTRY.
10. ASSEMBLY AIDS, REFER TO PAGE 35.

Wire Gauge	Code (Page 24)	Dimension A	Wire Insulation Diameter
22AWG (Stranded Wire)	122	0.47	1.10 to 1.60
24AWG (Stranded Wire)	132	0.37	1.10 to 1.60

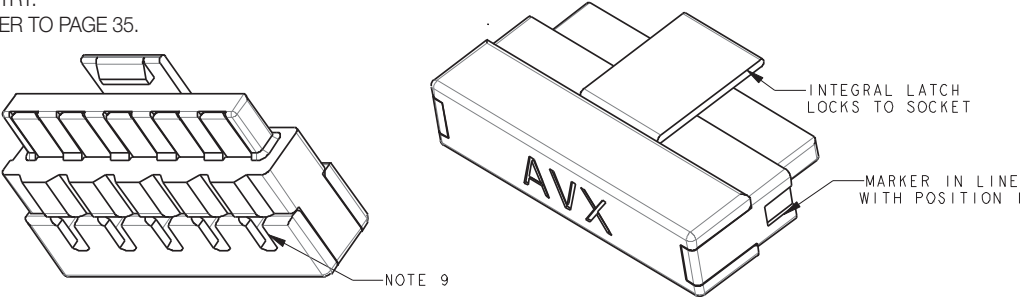

## PACKING DETAILS CAP AND CONNECTOR SUPPLIED TOGETHER (2 PARTS)

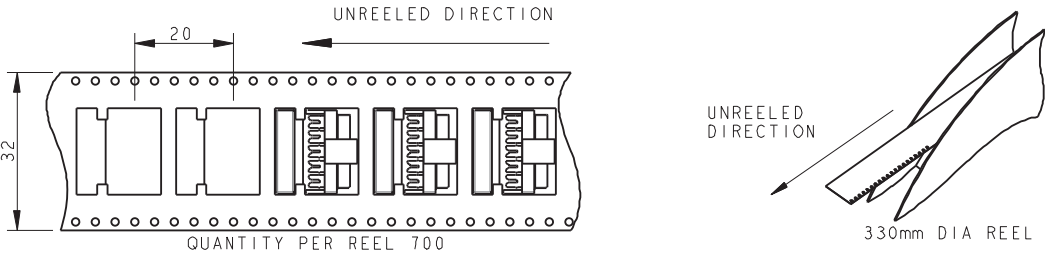

# IDC Plug: WTB Through Wire Cap/Wire Stop Cap



Series 14-9159

## PLUG-WIRED – 6 WAY WIRE STOP CAP

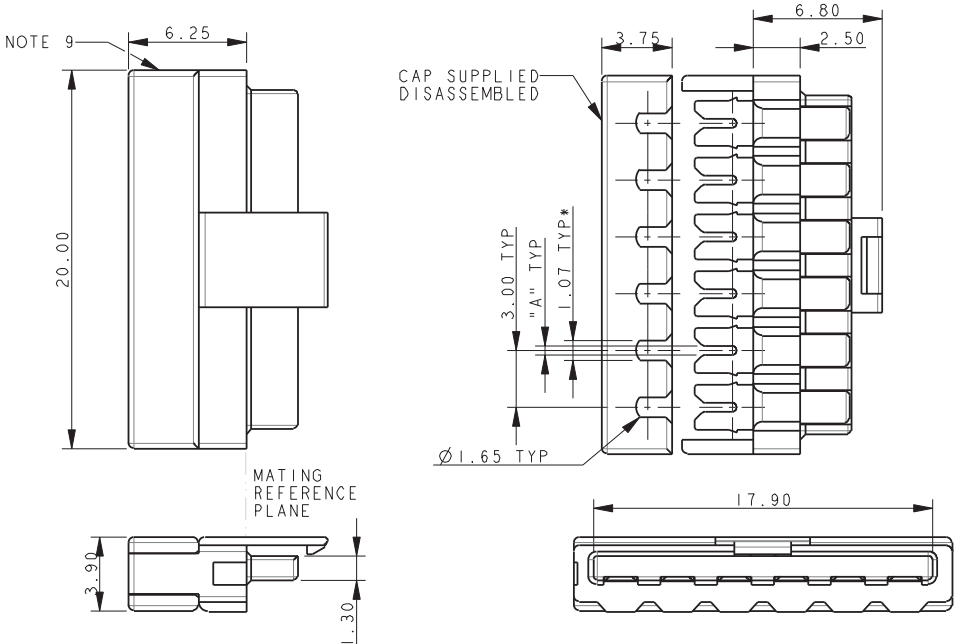

**NOTES:**

1. FOR MORE INFORMATION REFER TO PRODUCT SPEC 201-01-119.  
FOR WIRE ASSEMBLY REFER TO APPLICATION NOTES 201-01-123.
2. WIRE STOP CAP, WITH STOP FACE ON ONE SIDE TO PROTECT END OF WIRE.
3. CAP ACTS AS WIRE ASSEMBLY TOOL. WIRE PREFIT TO CAP, NARROW SLOT TO GRIP WIRE, PERMANENT ASSEMBLY.
4. GENERAL TOLERANCE  $\pm 0.20$  UNLESS SPECIFIED.
5. INSULATOR MATERIAL: NYLON 46, GLASS FILLED, UL94 V-0. COLOR REFER TO PAGE 24.
6. CONTACT MATERIAL: COPPER ALLOY, PLATING NICKEL BASE ALL OVER, GOLD ON CONTACT, TIN ON IDC.
7. PACKING IN TAPE AND REEL. QTY PER REEL 700, POCKET CONTAINS 1 CONNECTOR AND 1 CAP.
8. WIRE GAUGE OPTIONS, SEE TABLE.
9. SHOWN WITH WIRE ENTRY FROM UNDERSIDE, CAP CAN BE ASSEMBLED FOR EITHER TOP OR UNDERSIDE WIRE ENTRY.
10. ASSEMBLY AIDS, REFER TO PAGE 35.

Wire Gauge	Code (Page 24)	Dimension A	Wire Insulation Diameter
22AWG (Stranded Wire)	122	0.47	1.10 to 1.60
24AWG (Stranded Wire)	132	0.37	1.10 to 1.60

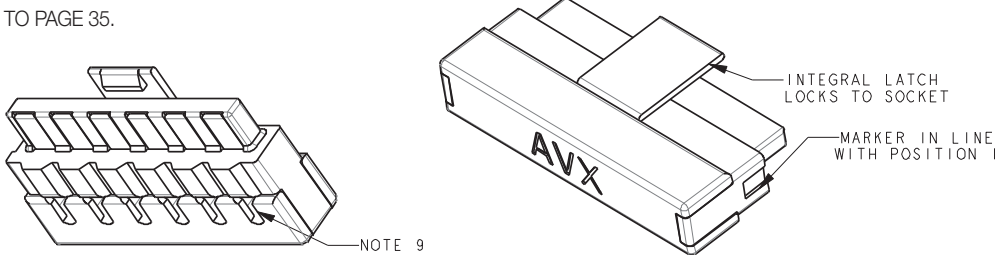

## PACKING DETAILS CAP AND CONNECTOR SUPPLIED TOGETHER (2 PARTS)

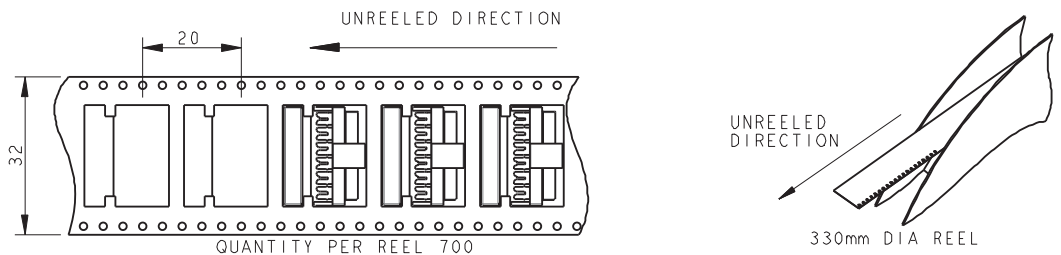

# IDC Plug: WTB Through Wire Cap/Wire Stop Cap

Series 14-9159

## PLUG-WIRED – ASSEMBLY SUPPORT BLOCK

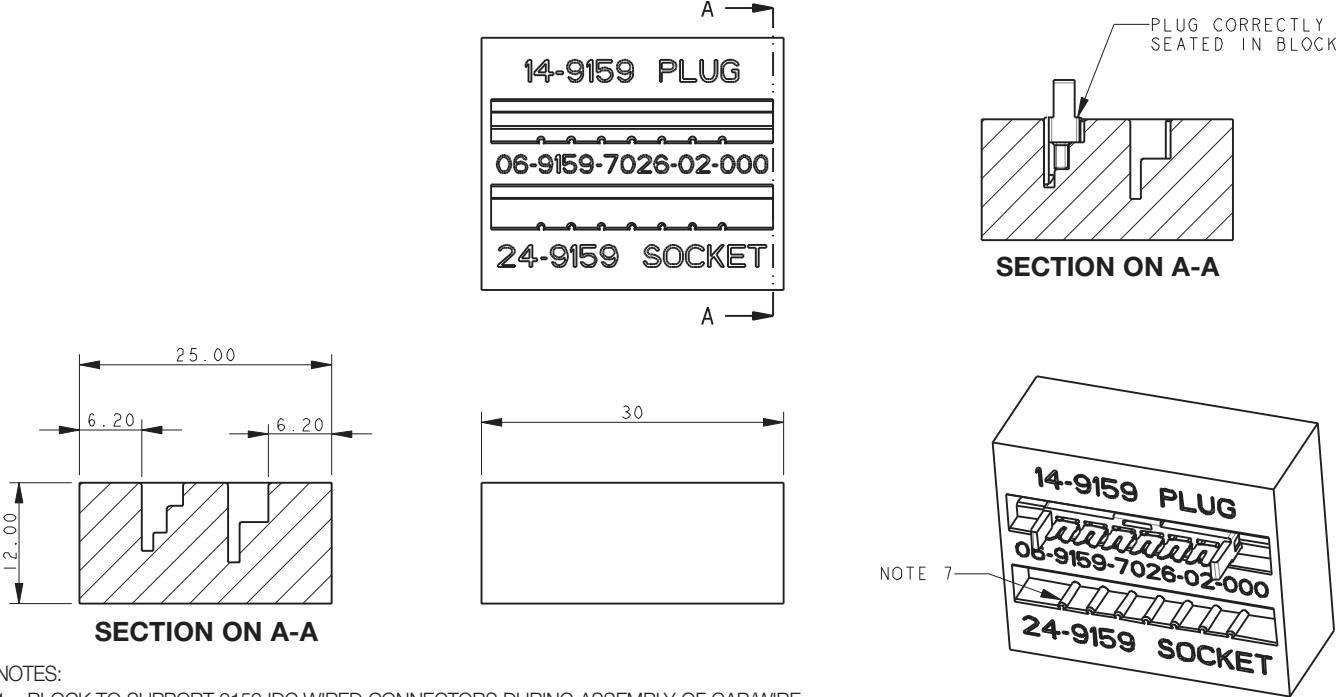

- NOTES:
1. BLOCK TO SUPPORT 9159 IDC WIRED CONNECTORS DURING ASSEMBLY OF CAP/WIRE.
  2. PART NUMBER 06-9159-7026-01-000, MATERIAL ALUMINUM.  
PART NUMBER 06-9159-7026-02-000, MATERIAL NYLON 46.
  3. CAN BE USED WITH EITHER THE PLUG OR SOCKET CONNECTORS, USE THE CORRECT SLOT AS IDENTIFIED.
  4. FOR FULL WIRE ASSEMBLY DETAILS REFER TO APPLICATION NOTES 201-01-123.
  5. ONLY A SIMPLE FLAT BOTTOMED TOOL REQUIRED TO PUSH THE CAP DOWN (NOT SUPPLIED.)
  6. ALL DIMENSIONS  $\pm 0.20$  UNLESS TOLERANCED.
  7. 06-9159-7026-02-000 HAS RIBS TO HELP LOCATE CONTACT/INSULATOR SUB-ASSEMBLY.

## PLUG-WIRED – WIRE INSERTION TOOL

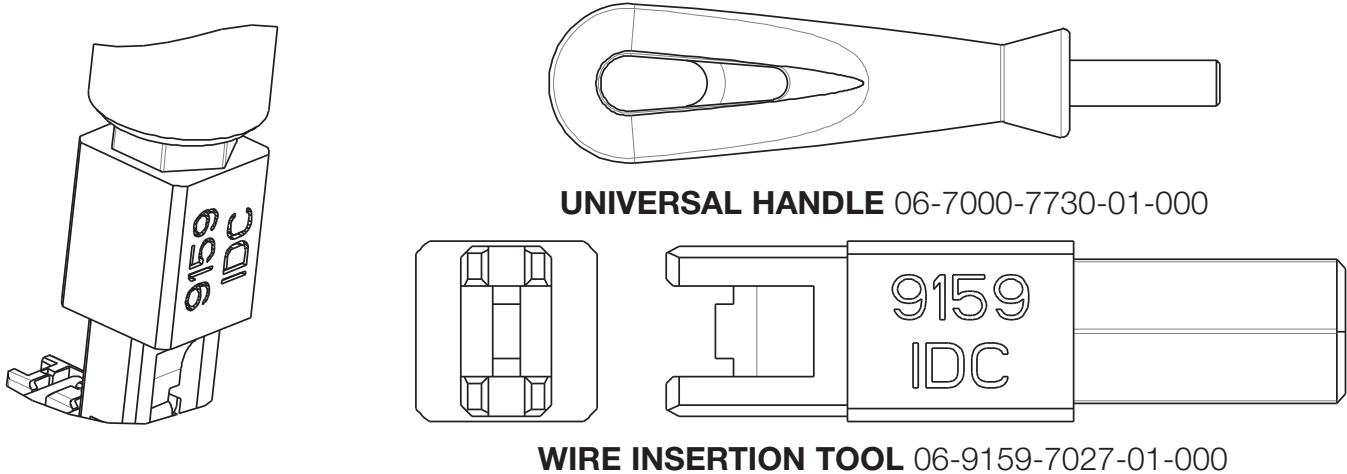

- NOTES:
1. TOOL 06-9159-7027-01-000 TO INSERT WIRES INTO CAP.
  2. FOR USE WITH UNIVERSAL HANDLE 06-7000-7720-01-000.
  3. CAN BE USED WITH BOTH THROUGH WIRE AND WIRE STOP CAPS.
  4. REFER TO APPLICATION NOTES 201-01-123 FOR FURTHER DETAILS.

# IDC Plug: WTB Through Wire Cap/Wire Stop Cap



Series 14-9159

## PLUG-WIRED – ASSEMBLY

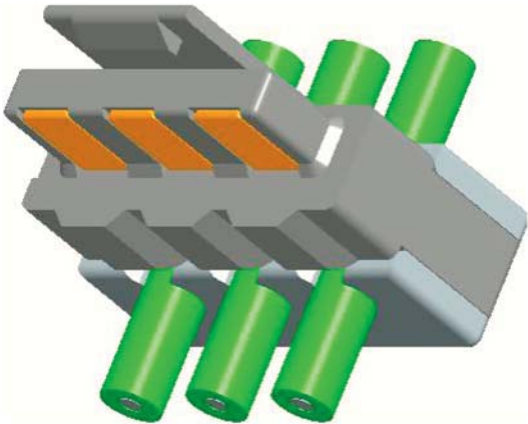

**THROUGH WIRE**

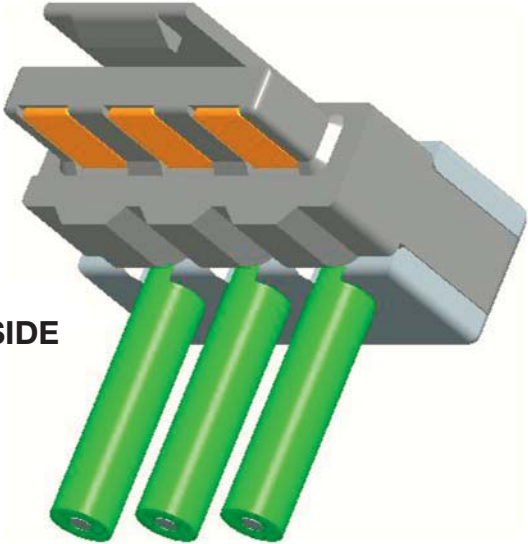

**WIRED STOP  
WIRE ENTRY UNDERSIDE**

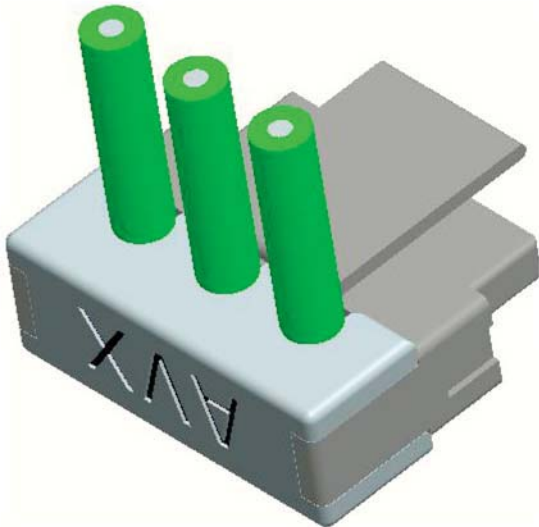

**WIRED STOP  
WIRE ENTRY TOP**



# Horizontal Socket

## Series 20-9159



The 9159 series of Board-to-Board interconnect system allows two PCB's to be mated end-to-end creating strips of LED lighting. Designed specifically for the unique Solid State Lighting (SSL) market requiring coplanar (horizontal-to-horizontal) PCB mating with a 5 Amp current rating in the smallest package available. These single sided SMT connectors are perfect for both FR4 and metal boards where you need to butt the boards up together to minimize separation. Availability of both white and black insulation colors make them perfect for lighting as well as industrial applications. With sizes from 2p-6p, these high reliability connectors boast gold plated beryllium copper receptacle contacts for harsh environments.

### APPLICATIONS

- Coplanar PCB mating in SSL products
- LED linear lighting strips
- Application Notes: refer to 201-01-123

### FEATURES AND BENEFITS

- Single sided SMT: supports FR4 and metal PCB's
- 5 Amp current rating: exceeds general market needs
- 5.5mm mated width: minimizes PCB space to decrease LED pitch
- Gold plated BeCu spring contacts: reliability for harsh environments
- Optional retaining clip: provides positive connector mating during vibration
- Available in white: supports SSL market preferences

### ELECTRICAL

- Current Rating: 5 Amps / Contact
- Voltage Rating: 125 VAC

### ENVIRONMENTAL

- Operating Temperature: -40°C to +125°C

### MECHANICAL

- Insulator Material: Nylon: VL94VO
- Contact Material: BeCu / Phos Bronze
- Plating: Gold / Tin over Nickel
- Durability: 10 Cycles

### HOW TO ORDER

**20**  
Prefix  
Socket

**9159**  
Series

**XXX**  
Number of Ways

Code	No of Ways	Details
002	2	Page 38
003	3	Page 39
004	4	Page 40
005	5	Page 41
006	6	Page 42

**1**  
2 Part  
PCB Strip  
Connector

**01**  
Connector  
Pitch  
01 = 3mm

**X**  
Color/Approval

Code	Color	Approval
1	White	Standard
9	White	UL Approved

**16**  
Plating Option

Code	Contact	Bracket
16	Gold in Contact Area Gold on Solder Tail	Tin all over



Certification: UL File #E90723



# Horizontal Socket

Series 20-9159



## SOCKET 2 WAY 2 PART PCB STRIP CONNECTOR

MARKER IN LINE WITH POSITION I

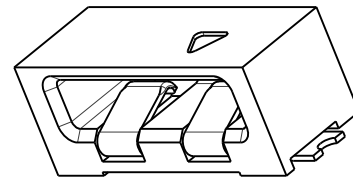
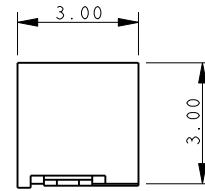
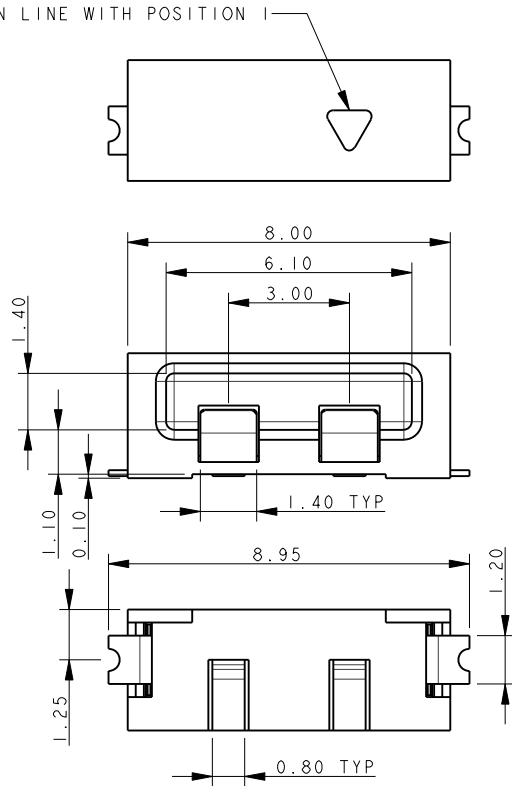

### NOTES:

1. FOR MORE INFORMATION REFER TO PRODUCT SPEC 201-01-119.
2. DIMENSIONS ARE REFERENCE DIMENSIONS UNLESS TOLERANCES.
3. INSULATOR MATERIAL: NYLON 46. COLOR REFER TO PAGE 37.
4. CONTACT MATERIAL: COPPER ALLOY, GOLD OVER NICKEL.
5. BRACKETS: COPPER ALLOY, TIN PLATED.
6. OUTLINE OF CONNECTOR.
7. PACKING TAPE AND REEL, QUANTITY 1400 PER REEL.

## 2 WAY PCB BOARD LAYOUT

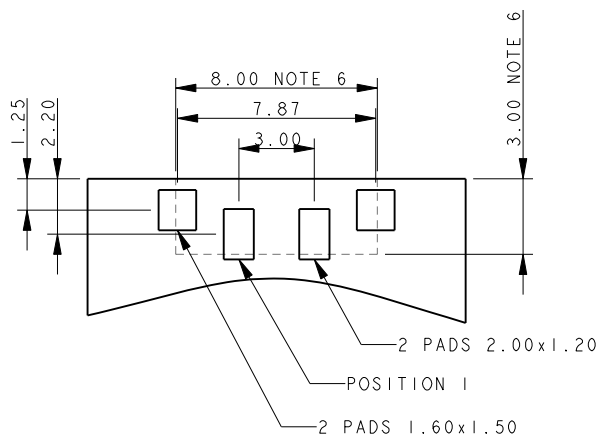

## PACKING DETAILS

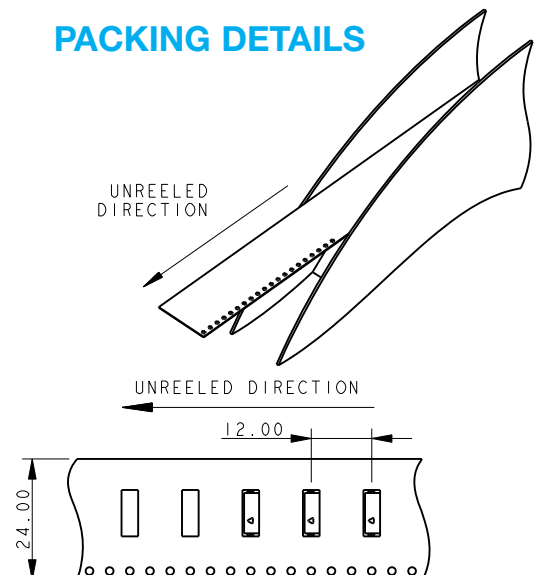



# Horizontal Socket

Series 20-9159



## SOCKET 3 WAY 2 PART PCB STRIP CONNECTOR

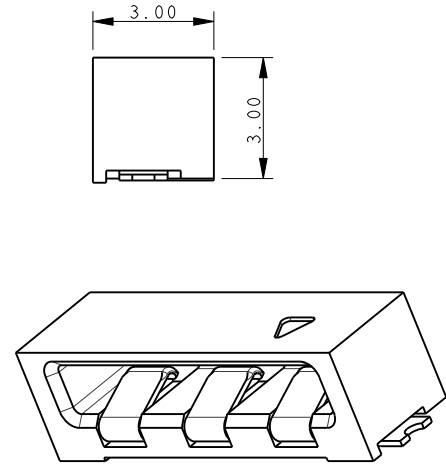
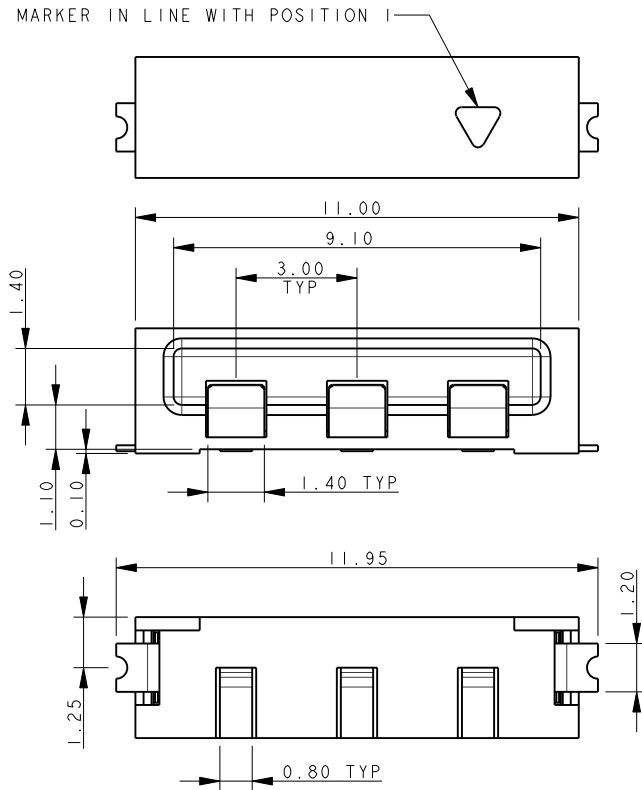

**NOTES:**

1. FOR MORE INFORMATION REFER TO PRODUCT SPEC 201-01-119.
2. DIMENSIONS ARE REFERENCE DIMENSIONS UNLESS TOLERANCES.
3. INSULATOR MATERIAL: NYLON 46. COLOR REFER TO PAGE 37.
4. CONTACT MATERIAL: COPPER ALLOY, GOLD OVER NICKEL.
5. BRACKETS: COPPER ALLOY, TIN PLATED.
6. OUTLINE OF CONNECTOR.
7. PACKING TAPE AND REEL, QUANTITY 1400 PER REEL.

## 3 WAY PCB BOARD LAYOUT

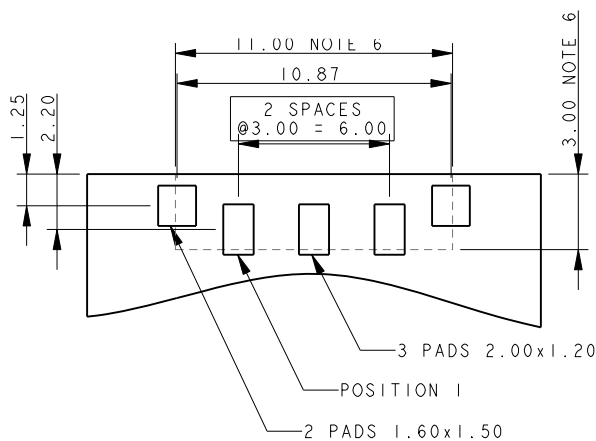

## PACKING DETAILS

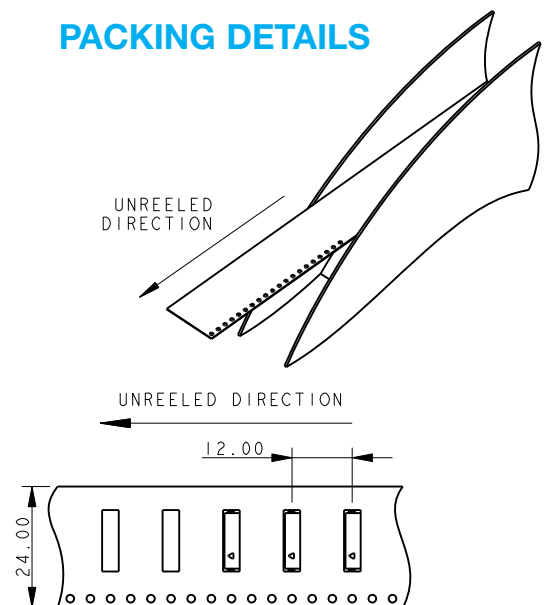

# Horizontal Socket

Series 20-9159



## SOCKET 4 WAY 2 PART PCB STRIP CONNECTOR

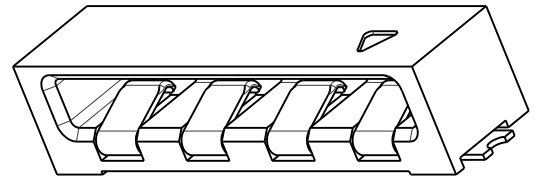
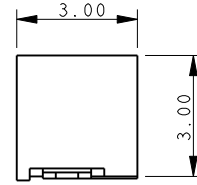
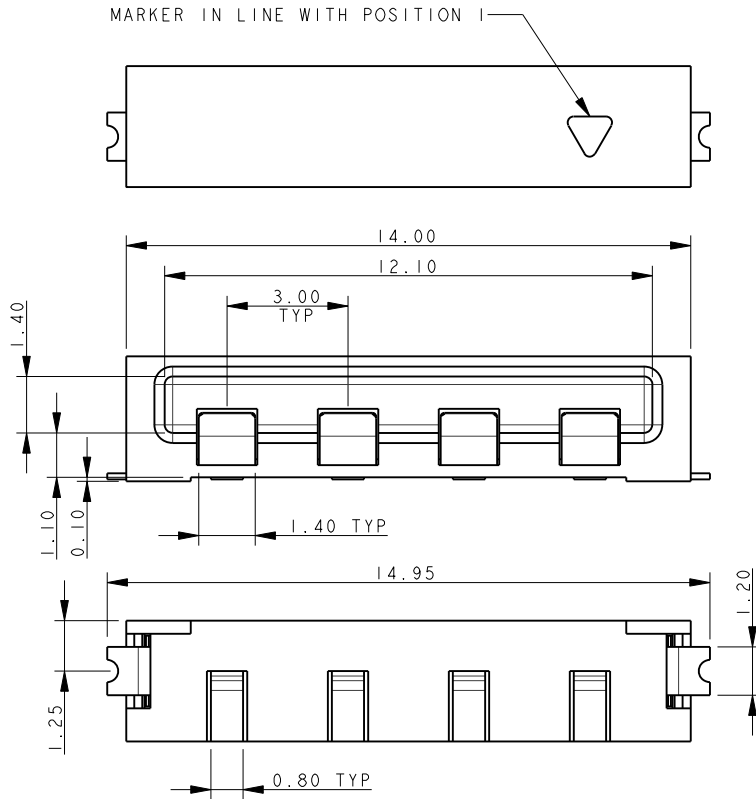

### NOTES:

1. FOR MORE INFORMATION REFER TO PRODUCT SPEC 201-01-119.
2. DIMENSIONS ARE REFERENCE DIMENSIONS UNLESS TOLERANCES.
3. INSULATOR MATERIAL: NYLON 46. COLOR REFER TO PAGE 37.
4. CONTACT MATERIAL: COPPER ALLOY, GOLD OVER NICKEL.
5. BRACKETS: COPPER ALLOY, TIN PLATED.
6. OUTLINE OF CONNECTOR.
7. PACKING TAPE AND REEL, QUANTITY 1400 PER REEL.

## 4 WAY PCB BOARD LAYOUT

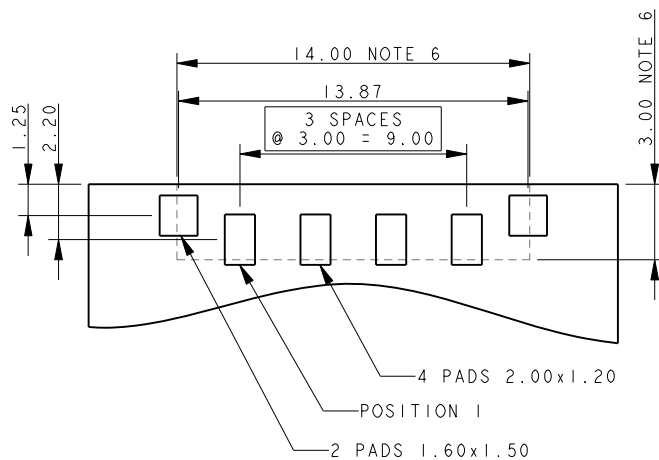

## PACKING DETAILS

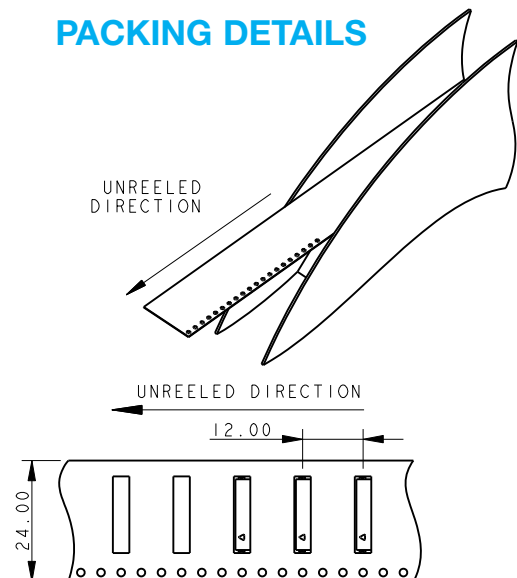

# Horizontal Socket

Series 20-9159



## SOCKET 5 WAY 2 PART PCB STRIP CONNECTOR

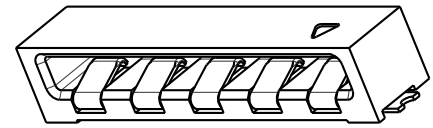
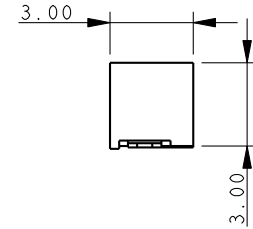
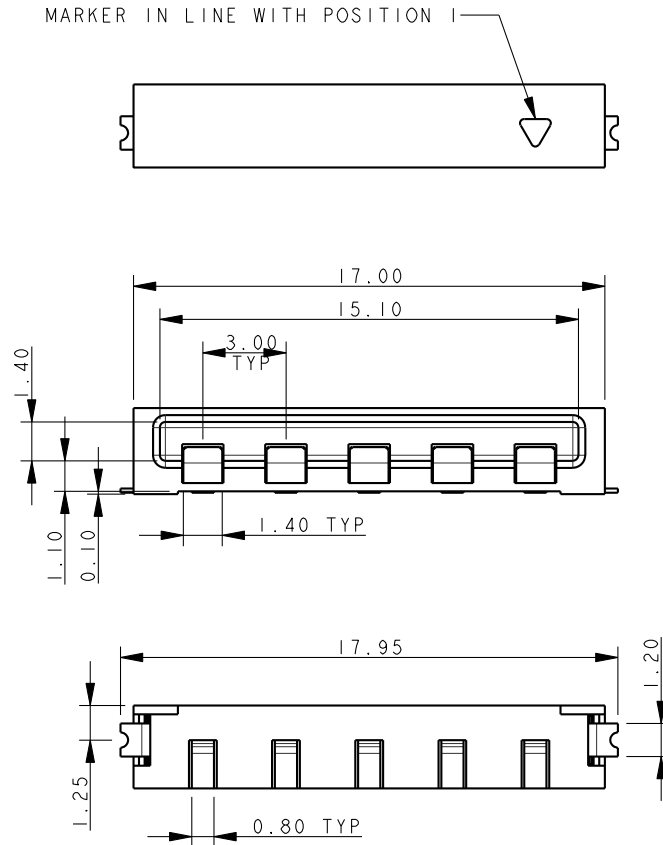

NOTES:

1. FOR MORE INFORMATION REFER TO PRODUCT SPEC 201-01-119.
2. DIMENSIONS ARE REFERENCE DIMENSIONS UNLESS TOLERANCES.
3. INSULATOR MATERIAL: NYLON 46. COLOR REFER TO PAGE 37.
4. CONTACT MATERIAL: COPPER ALLOY, GOLD OVER NICKEL.
5. BRACKETS: COPPER ALLOY, TIN PLATED.
6. OUTLINE OF CONNECTOR.
7. PACKING TAPE AND REEL, QUANTITY 1400 PER REEL.

## 5 WAY PCB BOARD LAYOUT

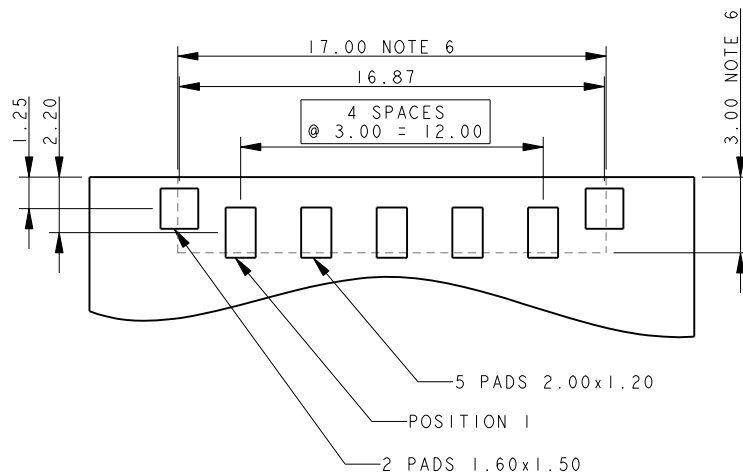

## PACKING DETAILS

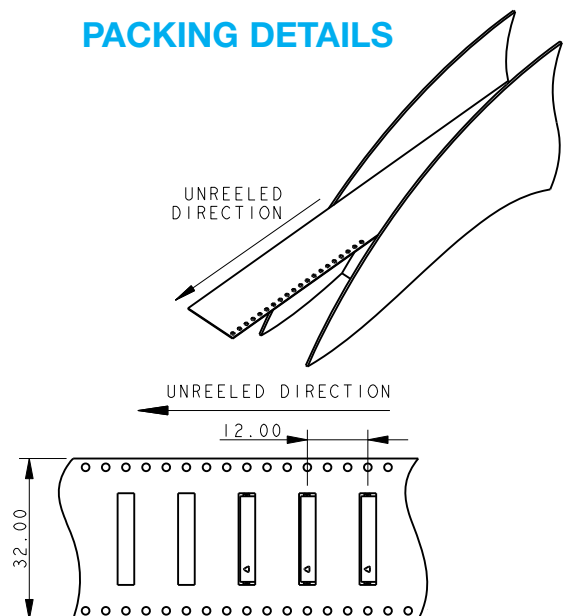

# Horizontal Socket

Series 20-9159



## SOCKET 6 WAY 2 PART PCB STRIP CONNECTOR

MARKER IN LINE WITH POSITION 1

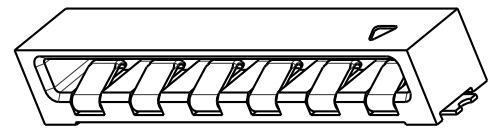
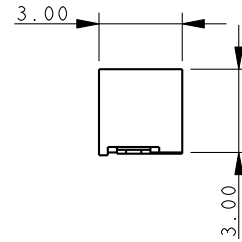
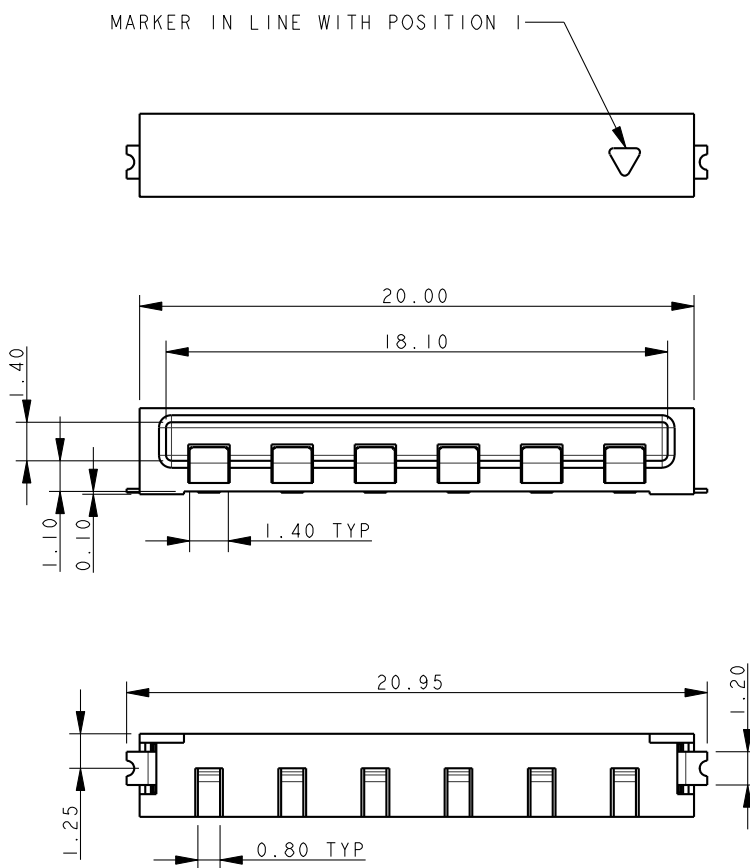

### NOTES:

1. FOR MORE INFORMATION REFER TO PRODUCT SPEC 201-01-119.
2. DIMENSIONS ARE REFERENCE DIMENSIONS UNLESS TOLERANCES.
3. INSULATOR MATERIAL: NYLON 46. COLOR REFER TO PAGE 37.
4. CONTACT MATERIAL: COPPER ALLOY, GOLD OVER NICKEL.
5. BRACKETS: COPPER ALLOY, TIN PLATED.
6. OUTLINE OF CONNECTOR.
7. PACKING TAPE AND REEL, QUANTITY 1400 PER REEL.

## 6 WAY PCB BOARD LAYOUT

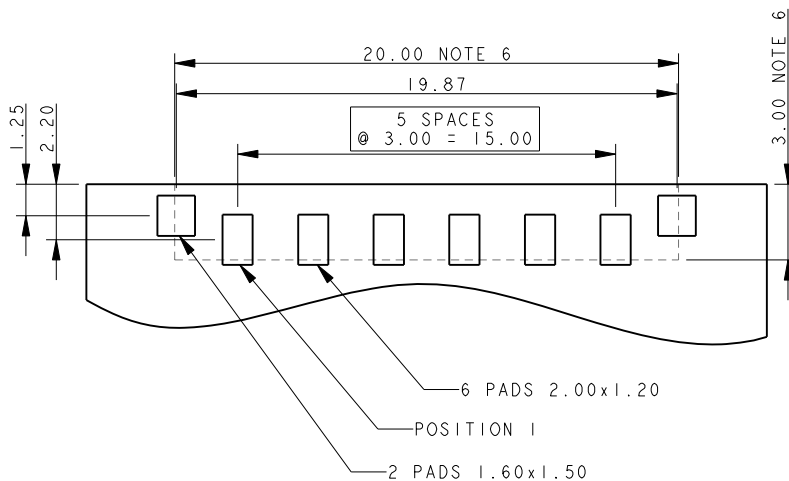

## PACKING DETAILS

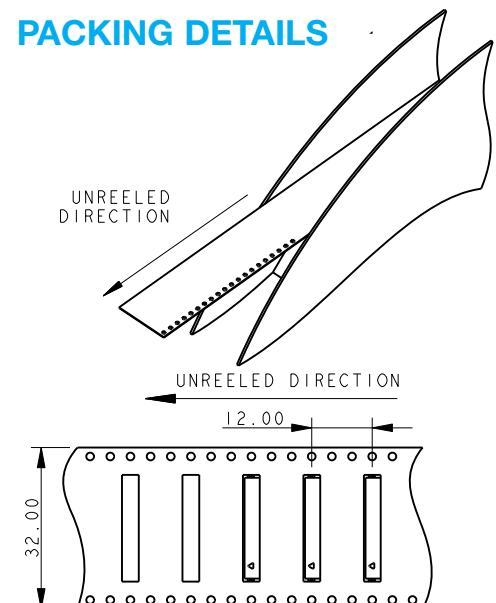

# Top Load Socket



## Series 22-9159



The 9159 series of Board-to-Board interconnect system allows two PCB's to be mated end-to-end creating strips of LED lighting. Designed specifically for the unique Solid State Lighting (SSL) market requiring coplanar (horizontal-to-horizontal) PCB mating with a 5 Amp current rating in the smallest package available. The top loading socket allows complete PCB's to be replaced in the field without having to disassemble the entire strip of boards. The connector has a two part insulator whereby the top of the connector will slide open allowing the plug connector to be pulled out either vertically or at a slight angle. Once the PCB is replaced, the cover is slid back like a Zero Insertion Force (ZIF) connector to the closed position. The PCB layout is identical to the standard horizontal socket to maintain family commonality at the PCB level.

### APPLICATIONS

- Coplanar PCB mating in SSL products
- LED linear lighting strips
- Application Notes: refer to 201-01-123

### FEATURES AND BENEFITS

- Slide open top: allows field reparability at the light fixture level
- Mates with standard horizontal or cabled plug: no need to change any connectors
- 5 Amp current rating: exceeds general market needs
- Gold plated BeCu spring contacts: reliability for harsh environments
- Available in white: supports SSL market preferences

### ELECTRICAL

- Current Rating: 5 Amps / Contact
- Voltage Rating: 125 VAC

### ENVIRONMENTAL

- Operating Temperature: -40°C to +125°C

### MECHANICAL

- Insulator Material: Nylon: VL94VO
- Contact Material: BeCu / Phos Bronze
- Plating: Gold / Tin over Nickel
- Durability: 10 Cycles

### HOW TO ORDER

<b>22</b>	<b>9159</b>	<b>XXX</b>	<b>1</b>	<b>01</b>	<b>X</b>	<b>16</b>																																	
Prefix Socket Top Loading	Series	Number of Ways	2 Part PCB Strip Connector	Connector Pitch 01 = 3mm	Color/Approval	Plating Option																																	
		<table border="1"> <thead> <tr> <th>Code</th> <th>No of Ways</th> <th>Details</th> </tr> </thead> <tbody> <tr> <td>002</td> <td>2</td> <td>Page 44</td> </tr> <tr> <td>003</td> <td>3</td> <td>Page 45</td> </tr> <tr> <td>004</td> <td>4</td> <td>Page 46</td> </tr> <tr> <td>005</td> <td>5</td> <td>Page 47</td> </tr> <tr> <td>006</td> <td>6</td> <td>Page 48</td> </tr> </tbody> </table>	Code	No of Ways	Details	002	2	Page 44	003	3	Page 45	004	4	Page 46	005	5	Page 47	006	6	Page 48			<table border="1"> <thead> <tr> <th>Code</th> <th>Color</th> <th>Approval</th> </tr> </thead> <tbody> <tr> <td>1</td> <td>White</td> <td>Standard</td> </tr> <tr> <td>9</td> <td>White</td> <td>UL Approved</td> </tr> </tbody> </table>	Code	Color	Approval	1	White	Standard	9	White	UL Approved	<table border="1"> <thead> <tr> <th>Code</th> <th>Contact</th> <th>Bracket</th> </tr> </thead> <tbody> <tr> <td>16</td> <td>Gold in Contact Area Tin on Solder Tail</td> <td>Tin all over</td> </tr> </tbody> </table>	Code	Contact	Bracket	16	Gold in Contact Area Tin on Solder Tail	Tin all over
Code	No of Ways	Details																																					
002	2	Page 44																																					
003	3	Page 45																																					
004	4	Page 46																																					
005	5	Page 47																																					
006	6	Page 48																																					
Code	Color	Approval																																					
1	White	Standard																																					
9	White	UL Approved																																					
Code	Contact	Bracket																																					
16	Gold in Contact Area Tin on Solder Tail	Tin all over																																					



Certification: UL File #E90723



# Top Load Socket

Series 22-9159



## SOCKET TOP LOADING 2 WAY 2 PART PCB STRIP CONNECTOR

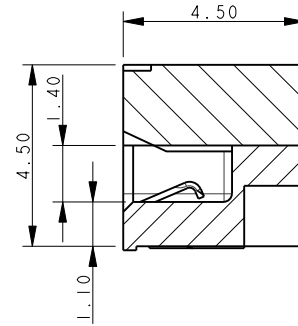
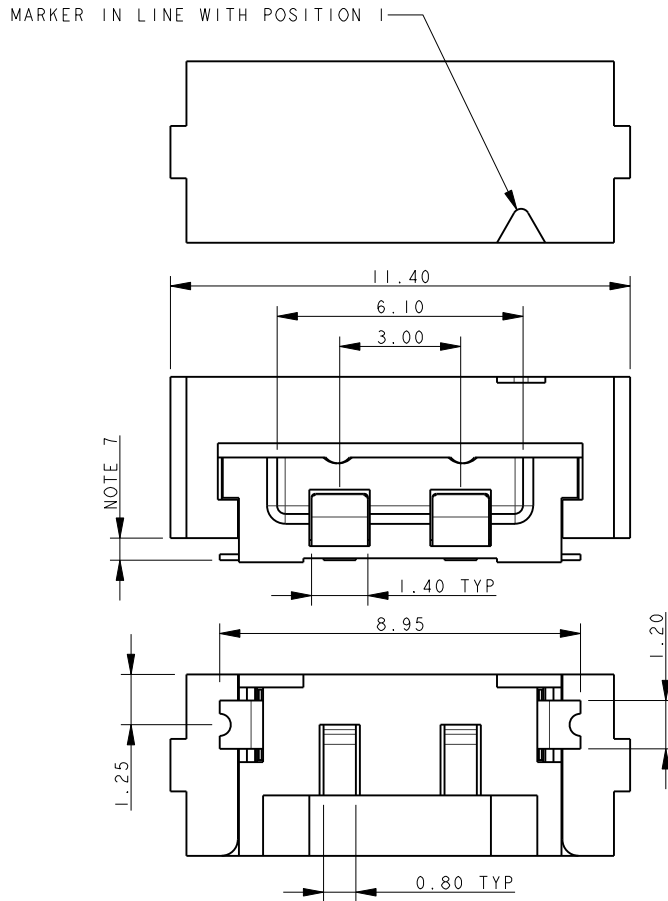

NOTES:

1. FOR MORE INFORMATION REFER TO PRODUCT SPEC 201-01-119.
2. DIMENSIONS ARE REFERENCE DIMENSIONS UNLESS TOLERANCES.
3. INSULATOR MATERIAL: NYLON 46. COLOR REFER TO PAGE 43.
4. CONTACT MATERIAL: COPPER ALLOY, GOLD OVER NICKEL.
5. BRACKETS: COPPER ALLOY, TIN PLATED.
6. OUTLINE OF CONNECTOR.
7. RESTRICTED COMPONENT HEIGHT UNDER CATCH, 2.20MM MAXIMUM.
8. RESTRICTED COMPONENT HEIGHT UNDER CATCH, 0.40MM MAXIMUM.
9. PACKING TAPE AND REEL, QUANTITY 1400 PER REEL.

## 2 WAY PCB BOARD LAYOUT

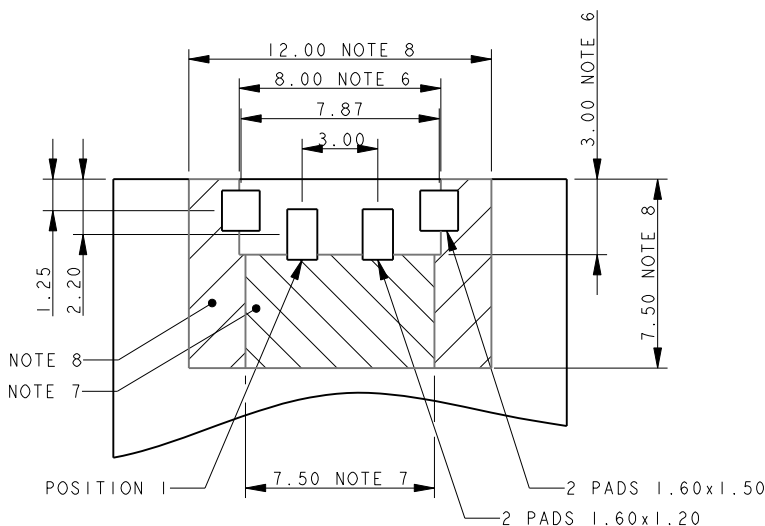

## PACKING DETAILS

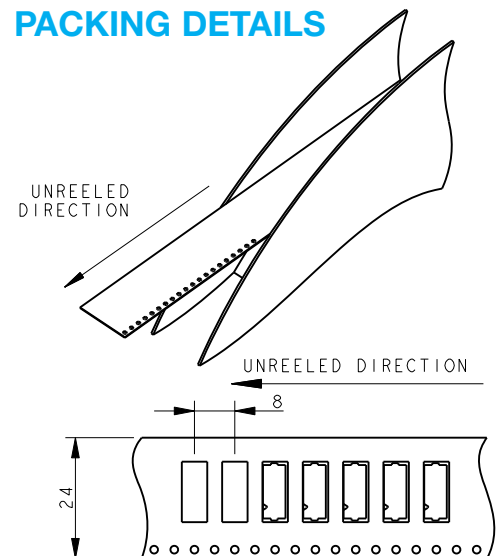

# Top Load Socket

Series 22-9159



## SOCKET TOP LOADING 3 WAY 2 PART PCB STRIP CONNECTOR

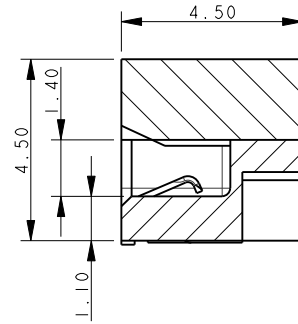
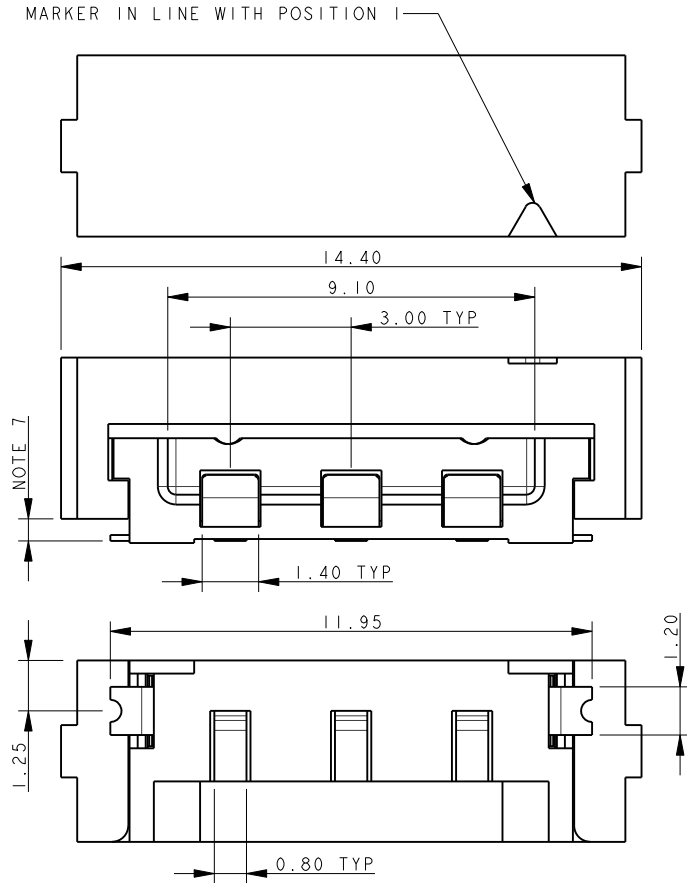

**NOTES:**

1. FOR MORE INFORMATION REFER TO PRODUCT SPEC 201-01-119.
2. DIMENSIONS ARE REFERENCE DIMENSIONS UNLESS TOLERANCES.
3. INSULATOR MATERIAL: NYLON 46. COLOR REFER TO PAGE 43.
4. CONTACT MATERIAL: COPPER ALLOY, GOLD OVER NICKEL.
5. BRACKETS: COPPER ALLOY, TIN PLATED.
6. OUTLINE OF CONNECTOR.
7. RESTRICTED COMPONENT HEIGHT UNDER CATCH, 2.20MM MAXIMUM.
8. RESTRICTED COMPONENT HEIGHT UNDER CATCH, 0.40MM MAXIMUM.
9. PACKING TAPE AND REEL, QUANTITY 1400 PER REEL.

### 3 WAY PCB BOARD LAYOUT

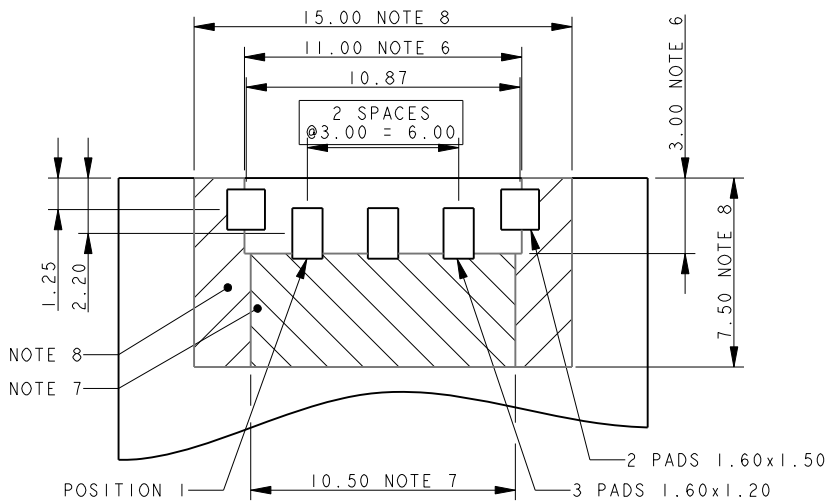

### PACKING DETAILS

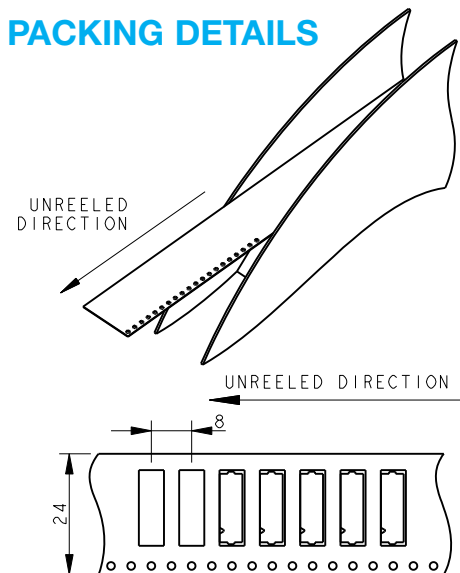

# Top Load Socket

Series 22-9159



## SOCKET TOP LOADING 4 WAY 2 PART PCB STRIP CONNECTOR

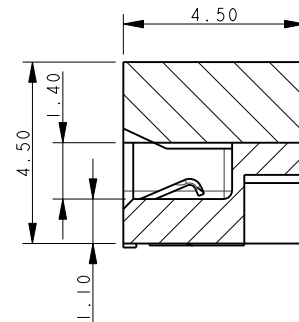
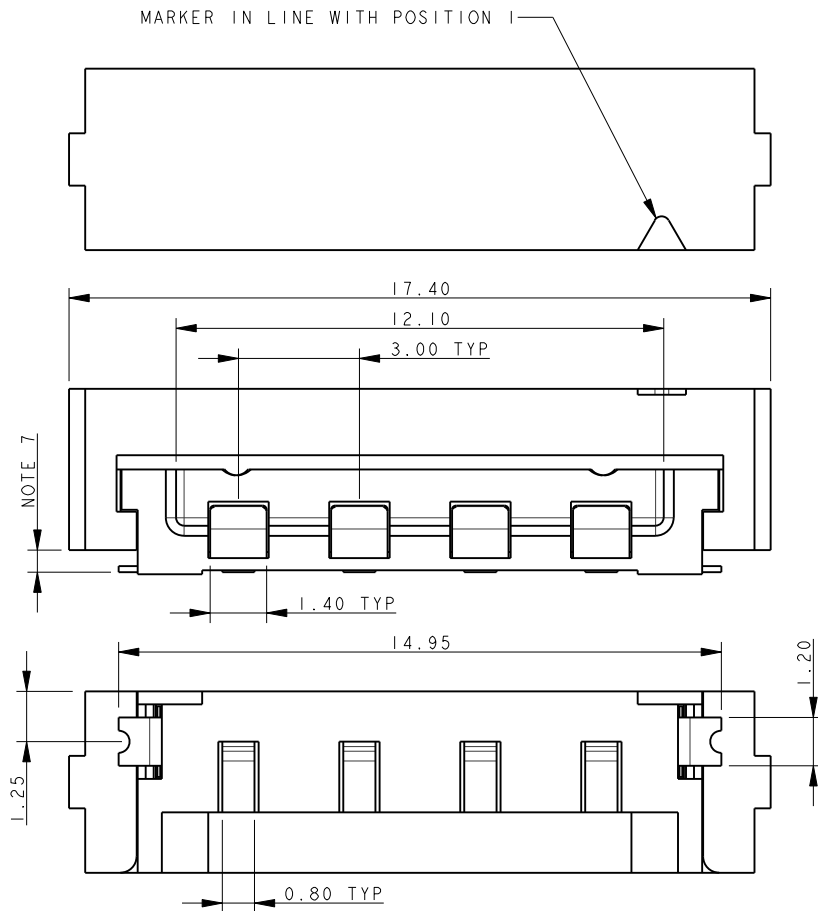

### NOTES:

1. FOR MORE INFORMATION REFER TO PRODUCT SPEC 201-01-119.
2. DIMENSIONS ARE REFERENCE DIMENSIONS UNLESS TOLERANCES.
3. INSULATOR MATERIAL: NYLON 46. COLOR REFER TO PAGE 43.
4. CONTACT MATERIAL: COPPER ALLOY, GOLD OVER NICKEL.
5. BRACKETS: COPPER ALLOY, TIN PLATED.
6. OUTLINE OF CONNECTOR.
7. RESTRICTED COMPONENT HEIGHT UNDER CATCH, 2.20MM MAXIMUM.
8. RESTRICTED COMPONENT HEIGHT UNDER CATCH, 0.40MM MAXIMUM.
9. PACKING TAPE AND REEL, QUANTITY 1400 PER REEL.

## 4 WAY PCB BOARD LAYOUT

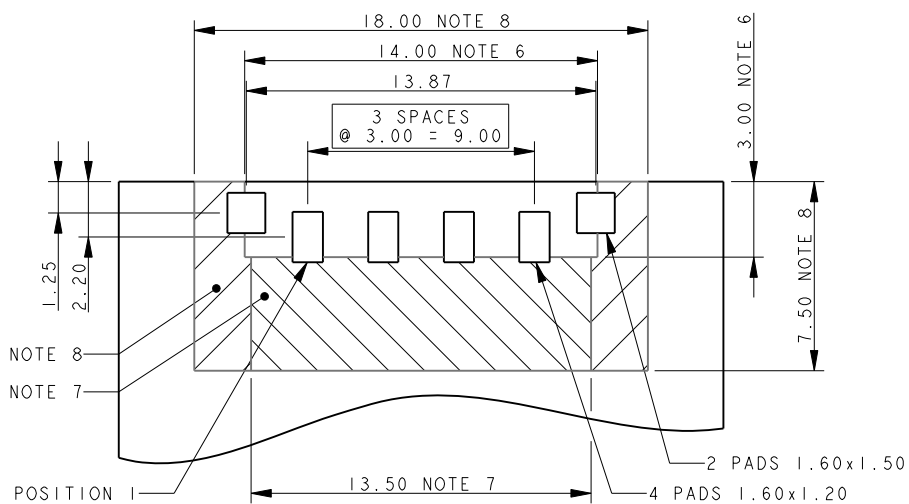

## PACKING DETAILS

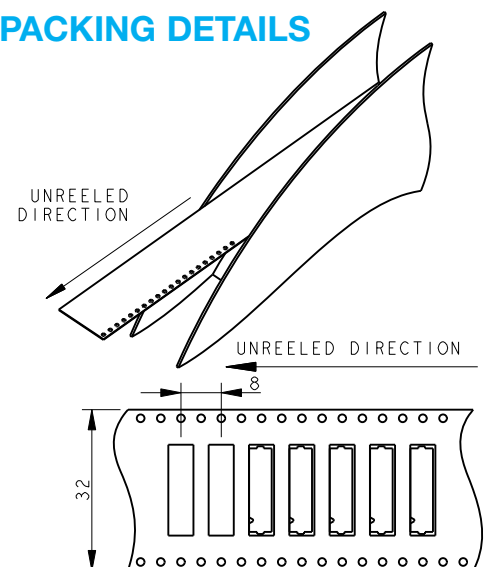



# Top Load Socket

Series 22-9159



## SOCKET TOP LOADING 5 WAY 2 PART PCB STRIP CONNECTOR

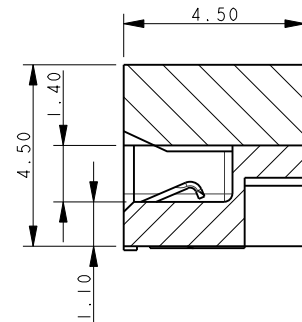
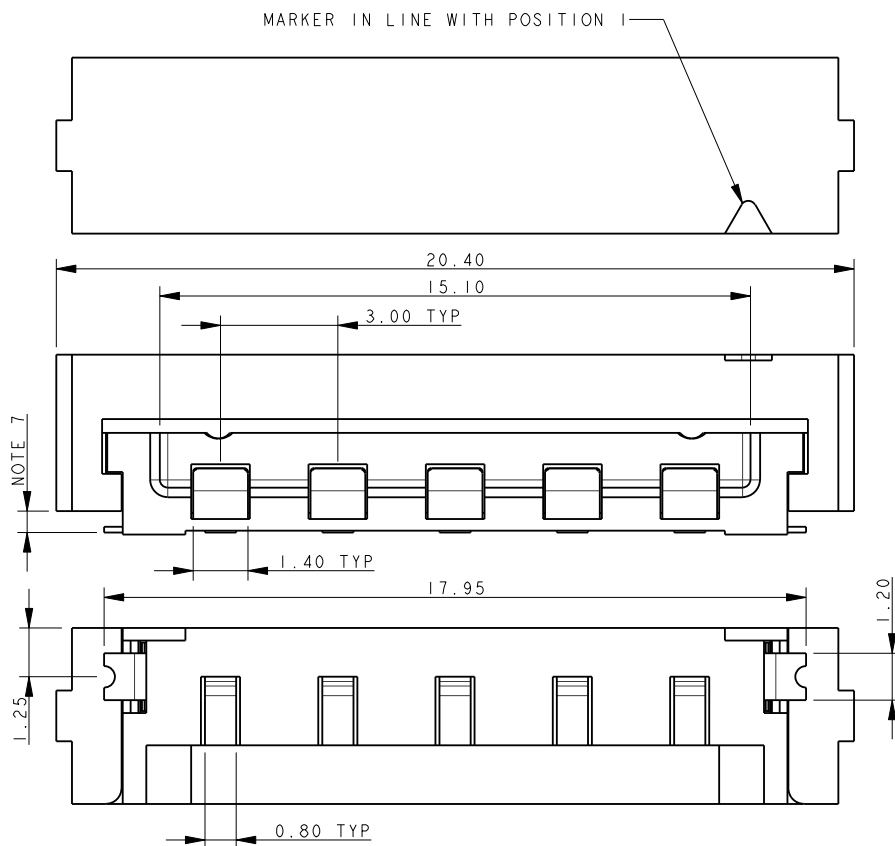

### NOTES:

1. FOR MORE INFORMATION REFER TO PRODUCT SPEC 201-01-119.
2. DIMENSIONS ARE REFERENCE DIMENSIONS UNLESS TOLERANCES.
3. INSULATOR MATERIAL: NYLON 46. COLOR REFER TO PAGE 43.
4. CONTACT MATERIAL: COPPER ALLOY, GOLD OVER NICKEL.
5. BRACKETS: COPPER ALLOY, TIN PLATED.
6. OUTLINE OF CONNECTOR.
7. RESTRICTED COMPONENT HEIGHT UNDER CATCH, 2.20MM MAXIMUM.
8. RESTRICTED COMPONENT HEIGHT UNDER CATCH, 0.40MM MAXIMUM.
9. PACKING TAPE AND REEL, QUANTITY 1400 PER REEL.

## 5 WAY PCB BOARD LAYOUT

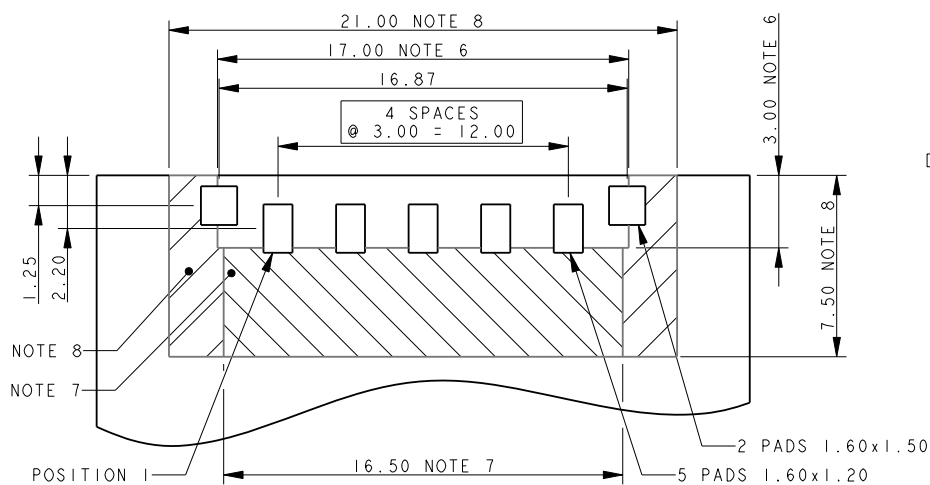

## PACKING DETAILS

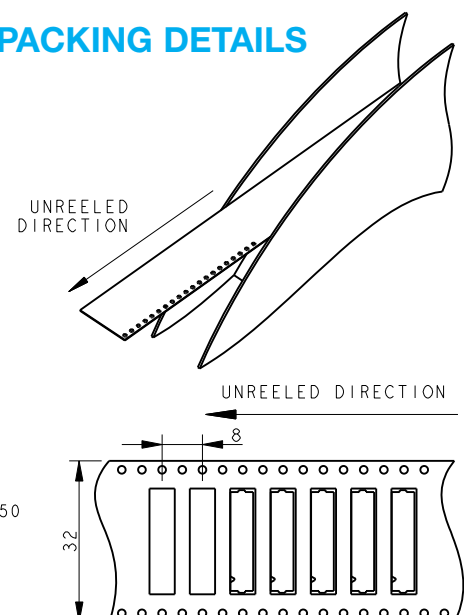

# Top Load Socket

Series 22-9159



## SOCKET TOP LOADING 6 WAY 2 PART PCB STRIP CONNECTOR

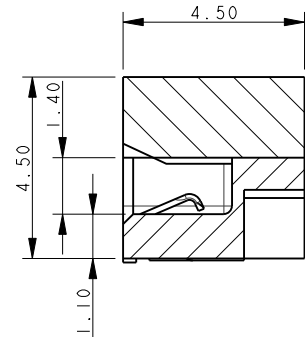
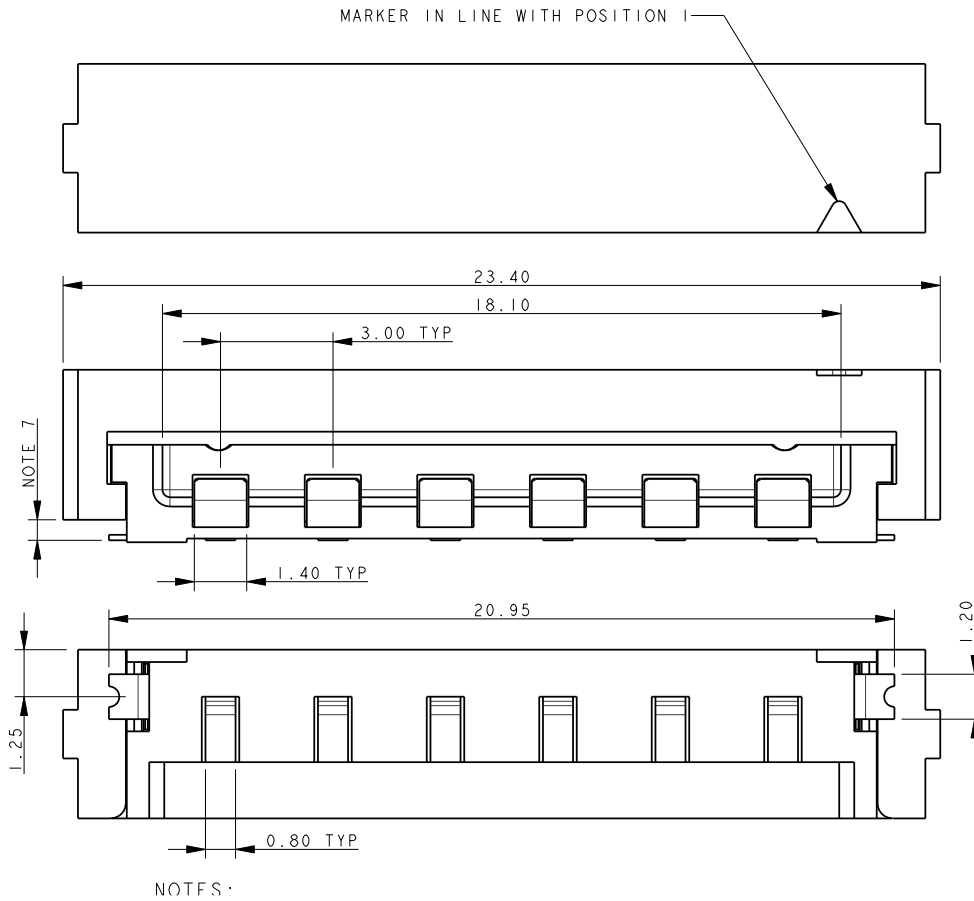

### NOTES:

1. FOR MORE INFORMATION REFER TO PRODUCT SPEC 201-01-119.
2. DIMENSIONS ARE REFERENCE DIMENSIONS UNLESS TOLERANCES.
3. INSULATOR MATERIAL: NYLON 46. COLOR REFER TO PAGE 43.
4. CONTACT MATERIAL: COPPER ALLOY, GOLD OVER NICKEL.
5. BRACKETS: COPPER ALLOY, TIN PLATED.
6. OUTLINE OF CONNECTOR.
7. RESTRICTED COMPONENT HEIGHT UNDER CATCH, 2.20MM MAXIMUM.
8. RESTRICTED COMPONENT HEIGHT UNDER CATCH, 0.40MM MAXIMUM.
9. PACKING TAPE AND REEL, QUANTITY 1400 PER REEL.

## 6 WAY PCB BOARD LAYOUT

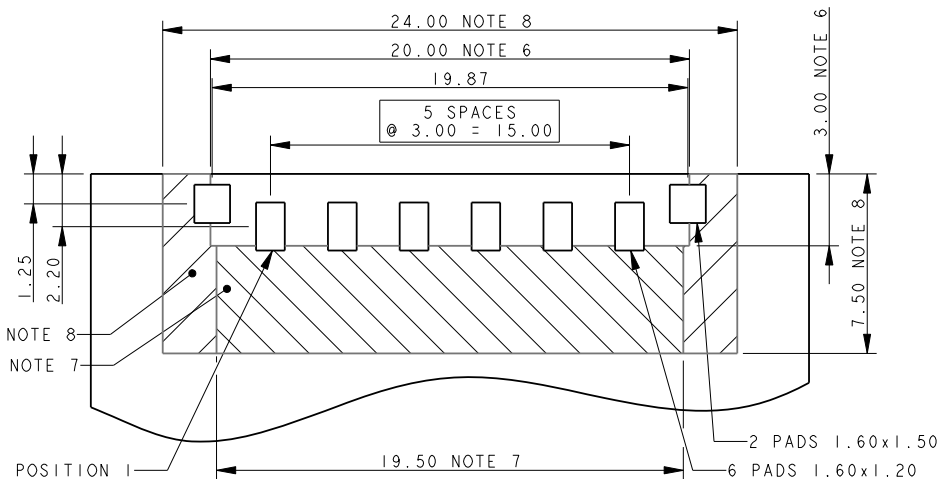

## PACKING DETAILS

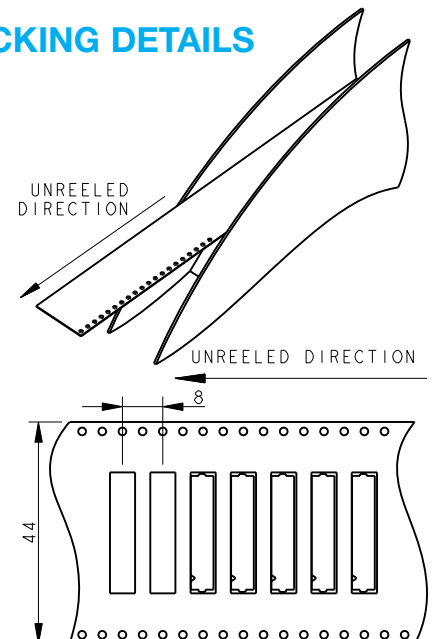

# Top Load Socket

Series 22-9159



## CONNECTOR ASSEMBLY



COVER FORWARD (LOCKED)



COVER SLID BACK



DROP PCB ASSEMBLY ONTO MATING CONNECTORS

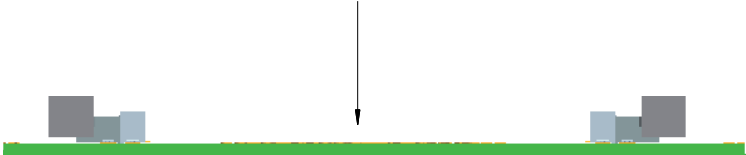



# IDC Socket: WTB Through Wire Cap/Wire Stop Cap

## Series 24-9159



AVX developed the 9159 Series of SMT connectors for co-planar PCB mating for the challenging Solid State Lighting (SSL) market. These connectors needed to be small, low in height, carry up to 5 Amps/contact and then function up to 125C for extended periods. This application has been very unique to the SSL market where PCB's are stacked end-to-end to create linear strip lighting in everything from office to transportation applications where products are exposed to harsh mechanical and environmental environments.

The IDC cable socket connector allows for 22-24AWG discrete or cabled wires to be easily and reliability terminated into a 9159 standard interface plug connector. This will allow power and signals to be connectors onto a PCB socket connector while providing positive latching. The wire assembly support block allows for 2 through 6 wires to be terminated all in one step with any standard bench top press. IDC covers provide both through (daisy chain applications) and wire stop termination options.

### APPLICATIONS

- Provides Wire-to-Board capabilities to standard 9159 2-Piece connector system
- In conjunction with the IDC plug WTB connector (14-9159), these connectors provide maximum flexibility to bring power and signal wires onto or off of any board level 9159 connector
- Reference application notes 201-01-123
- Reference Product Specification 201-01-119

### FEATURES AND BENEFITS

- Mates with standard 9159 horizontal plug, keeping same BTB connector system
- Economical and reliable IDC wire termination
- Gold plated BeCu contact system for high reliability in harsh environments
- Integrally molded latch offers positive latching after mating

### ELECTRICAL

- Current Rating: 5 Amps / Contact
- Voltage Rating: 125 VAC

### ENVIRONMENTAL

- Operating Temperature: -40°C to +125°C

### MECHANICAL

- Insulator Material: Nylon: UL94V0
- Contact Material: Phosphor Bronze
- Plating: Gold / Tin over Nickel
- Durability: 10 Cycles

### HOW TO ORDER

<p><b>24</b></p> <p>Prefix Right Angle Wired Socket IDC Terminations</p>	<p><b>9159</b></p> <p>Series</p>	<p><b>XXX</b></p> <p>Number of Ways</p> <table border="1" style="font-size: 8px; border-collapse: collapse; width: 100%;"> <thead> <tr> <th>Code</th> <th>No of Ways</th> <th>Details</th> </tr> </thead> <tbody> <tr> <td colspan="3">THROUGH WIRE CAP</td> </tr> <tr> <td>002</td> <td>2</td> <td>Page 51</td> </tr> <tr> <td>003</td> <td>3</td> <td>Page 52</td> </tr> <tr> <td>004</td> <td>4</td> <td>Page 53</td> </tr> <tr> <td>005</td> <td>5</td> <td>Page 54</td> </tr> <tr> <td>006</td> <td>6</td> <td>Page 55</td> </tr> <tr> <td colspan="3">WIRE STOP CAP</td> </tr> <tr> <td>002</td> <td>2</td> <td>Page 56</td> </tr> <tr> <td>003</td> <td>3</td> <td>Page 57</td> </tr> <tr> <td>004</td> <td>4</td> <td>Page 58</td> </tr> <tr> <td>005</td> <td>5</td> <td>Page 59</td> </tr> <tr> <td>006</td> <td>6</td> <td>Page 60</td> </tr> </tbody> </table>	Code	No of Ways	Details	THROUGH WIRE CAP			002	2	Page 51	003	3	Page 52	004	4	Page 53	005	5	Page 54	006	6	Page 55	WIRE STOP CAP			002	2	Page 56	003	3	Page 57	004	4	Page 58	005	5	Page 59	006	6	Page 60	<p><b>1</b></p> <p>2 Part PCB Strip Connector 2 Part Wired IDC Strip Connector</p>	<p><b>X</b></p> <p>Wire Gauge 2 = 22AWG 3 = 24AWG</p>	<p><b>2</b></p> <p>Wire Insulation Diameter ø1.10mm to ø1.60mm</p>	<p><b>9</b></p> <p>Color Options 9 = UL 1 = White</p>	<p><b>X</b></p> <p>Cap Options</p> <table border="1" style="font-size: 8px; border-collapse: collapse; width: 100%;"> <thead> <tr> <th>Code</th> <th>Cap Option</th> <th>Description</th> </tr> </thead> <tbody> <tr> <td>0</td> <td>Through Wire</td> <td>Allows wires to be terminated at any point</td> </tr> <tr> <td>9</td> <td>Wire Stop</td> <td>Terminates end of wire. End protected with Stop Face</td> </tr> </tbody> </table>	Code	Cap Option	Description	0	Through Wire	Allows wires to be terminated at any point	9	Wire Stop	Terminates end of wire. End protected with Stop Face	<p><b>6</b></p> <p>Plating Option</p> <table border="1" style="font-size: 8px; border-collapse: collapse; width: 100%;"> <thead> <tr> <th>Code</th> <th>Contact</th> </tr> </thead> <tbody> <tr> <td>6</td> <td>Gold on Contact Tin on IDC</td> </tr> </tbody> </table>	Code	Contact	6	Gold on Contact Tin on IDC
Code	No of Ways	Details																																																										
THROUGH WIRE CAP																																																												
002	2	Page 51																																																										
003	3	Page 52																																																										
004	4	Page 53																																																										
005	5	Page 54																																																										
006	6	Page 55																																																										
WIRE STOP CAP																																																												
002	2	Page 56																																																										
003	3	Page 57																																																										
004	4	Page 58																																																										
005	5	Page 59																																																										
006	6	Page 60																																																										
Code	Cap Option	Description																																																										
0	Through Wire	Allows wires to be terminated at any point																																																										
9	Wire Stop	Terminates end of wire. End protected with Stop Face																																																										
Code	Contact																																																											
6	Gold on Contact Tin on IDC																																																											



Certification: UL File #E90723



# IDC Socket: WTB Through Wire Cap/Wire Stop Cap



Series 24-9159

## SOCKET WIRED – 2 WAY THROUGH WIRE CAP

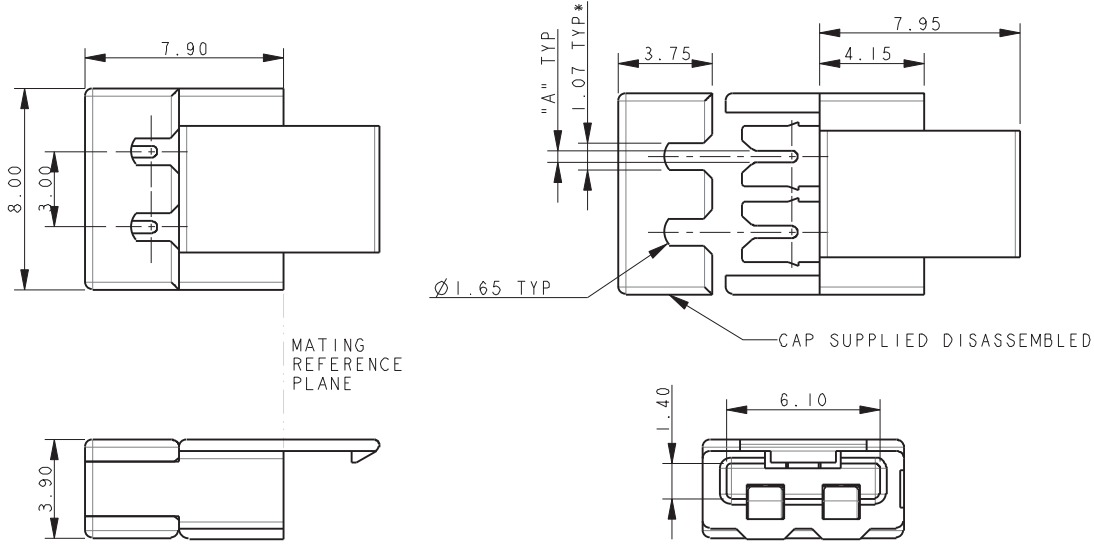

**NOTES:**

1. FOR MORE INFORMATION REFER TO PRODUCT SPEC 201-01-119.  
FOR WIRE ASSEMBLY REFER TO APPLICATION NOTES 201-01-123.
2. THROUGH WIRE CAP, FOR TERMINATION OF WIRE IN ANY POSITION.
3. CAP ACTS AS WIRE ASSEMBLY TOOL. WIRE PREFIT TO CAP, NARROW SLOT TO GRIP WIRE, PERMANENT ASSEMBLY.
4. GENERAL TOLERANCE  $\pm 0.20$  UNLESS SPECIFIED.
5. INSULATOR MATERIAL: NYLON 46, GLASS FILLED, UL94 V-0. COLOR REFER TO PAGE 50.
6. CONTACT MATERIAL: COPPER ALLOY, PLATING NICKEL BASE ALL OVER, GOLD ON CONTACT, TIN ON IDC.
7. PACKING IN TAPE AND REEL. QTY PER REEL 700, POCKET CONTAINS 1 CONNECTOR AND 1 CAP.
8. WIRE GAUGE OPTIONS, SEE TABLE.
9. ASSEMBLY AIDS, REFER TO PAGE 61.

Wire Gauge	Code (Page 50)	Dimension A	Wire Insulation Diameter
22AWG (Stranded Wire)	122	0.47	1.10 to 1.60
24AWG (Stranded Wire)	132	0.37	1.10 to 1.60

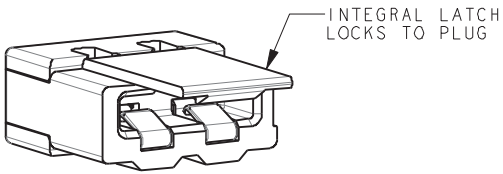
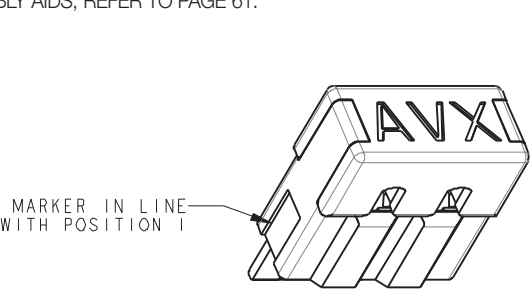

## PACKING DETAILS CAP AND CONNECTOR SUPPLIED TOGETHER (2 PARTS)

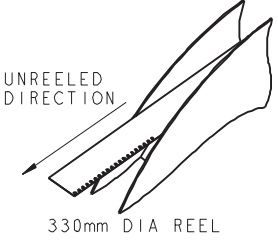
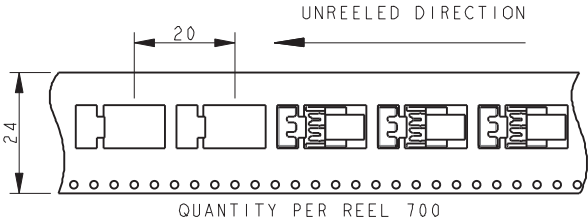

# IDC Socket: WTB Through Wire Cap/Wire Stop Cap



Series 24-9159

## SOCKET WIRED – 3 WAY THROUGH WIRE CAP

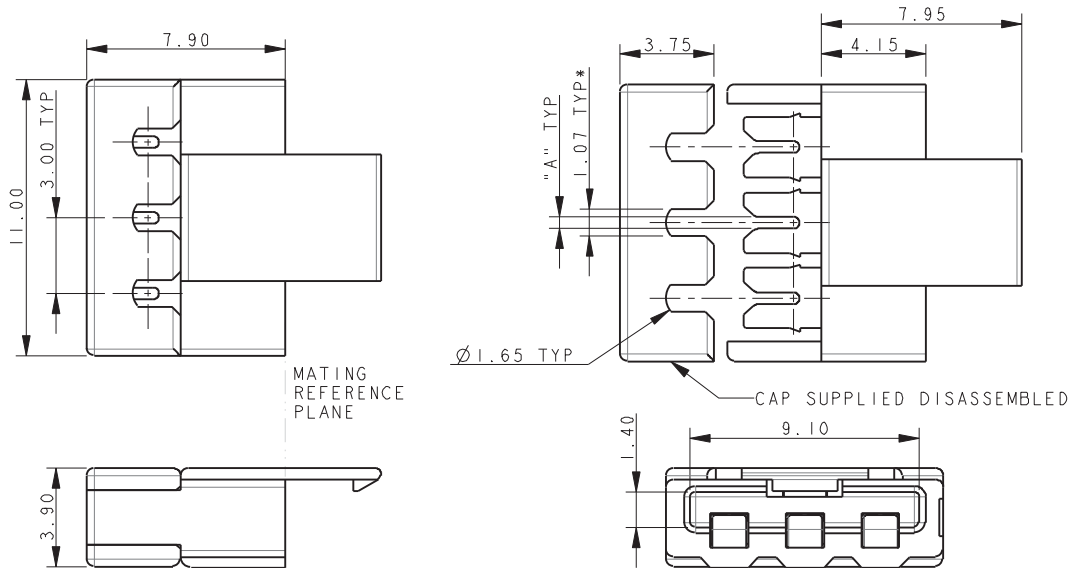

### NOTES:

1. FOR MORE INFORMATION REFER TO PRODUCT SPEC 201-01-119.  
FOR WIRE ASSEMBLY REFER TO APPLICATION NOTES 201-01-123.
2. THROUGH WIRE CAP, FOR TERMINATION OF WIRE IN ANY POSITION.
3. CAP ACTS AS WIRE ASSEMBLY TOOL. WIRE PREFIT TO CAP, NARROW SLOT TO GRIP WIRE, PERMANENT ASSEMBLY.
4. GENERAL TOLERANCE  $\pm 0.20$  UNLESS SPECIFIED.
5. INSULATOR MATERIAL: NYLON 46, GLASS FILLED, UL94 V-0. COLOR REFER TO PAGE 50.
6. CONTACT MATERIAL: COPPER ALLOY, PLATING NICKEL BASE ALL OVER, GOLD ON CONTACT, TIN ON IDC.
7. PACKING IN TAPE AND REEL. QTY PER REEL 700, POCKET CONTAINS 1 CONNECTOR AND 1 CAP.
8. WIRE GAUGE OPTIONS, SEE TABLE.
9. ASSEMBLY AIDS, REFER TO PAGE 61.

Wire Gauge	Code (Page 50)	Dimension A	Wire Insulation Diameter
22AWG (Stranded Wire)	122	0.47	1.10 to 1.60
24AWG (Stranded Wire)	132	0.37	1.10 to 1.60

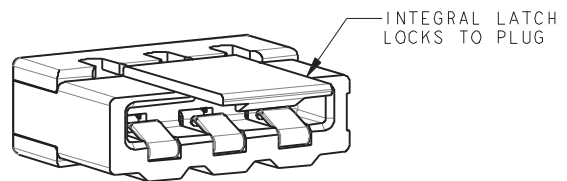
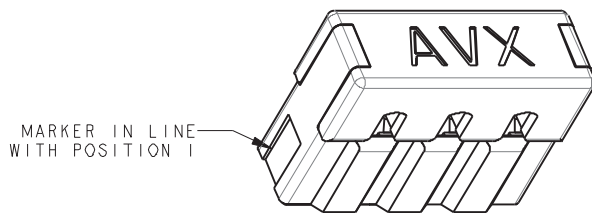

## PACKING DETAILS CAP AND CONNECTOR SUPPLIED TOGETHER (2 PARTS)

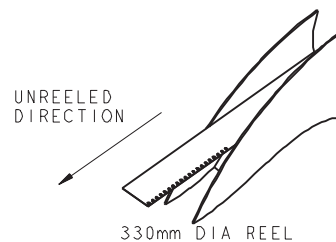
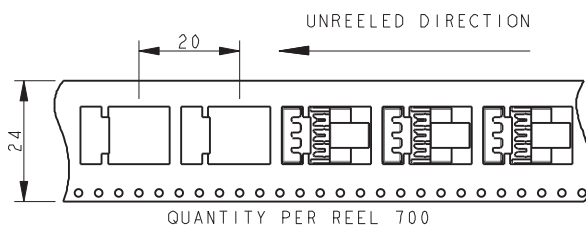

# IDC Socket: WTB Through Wire Cap/Wire Stop Cap



Series 24-9159

## SOCKET WIRED – 4 WAY THROUGH WIRE CAP

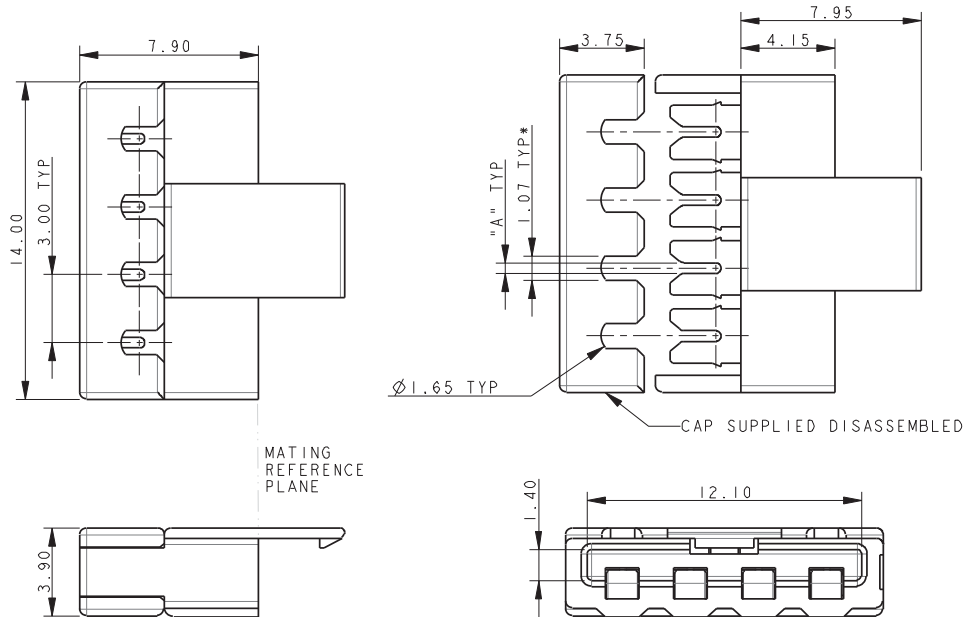

### NOTES:

1. FOR MORE INFORMATION REFER TO PRODUCT SPEC 201-01-119.  
FOR WIRE ASSEMBLY REFER TO APPLICATION NOTES 201-01-123.
2. THROUGH WIRE CAP, FOR TERMINATION OF WIRE IN ANY POSITION.
3. CAP ACTS AS WIRE ASSEMBLY TOOL. WIRE PREFIT TO CAP, NARROW SLOT TO GRIP WIRE, PERMANENT ASSEMBLY.
4. GENERAL TOLERANCE  $\pm 0.20$  UNLESS SPECIFIED.
5. INSULATOR MATERIAL: NYLON 46, GLASS FILLED, UL94 V-0. COLOR REFER TO PAGE 50.
6. CONTACT MATERIAL: COPPER ALLOY, PLATING NICKEL BASE ALL OVER, GOLD ON CONTACT, TIN ON IDC.
7. PACKING IN TAPE AND REEL. QTY PER REEL 700, POCKET CONTAINS 1 CONNECTOR AND 1 CAP.
8. WIRE GAUGE OPTIONS, SEE TABLE.
9. ASSEMBLY AIDS, REFER TO PAGE 61.

Wire Gauge	Code (Page 50)	Dimension A	Wire Insulation Diameter
22AWG (Stranded Wire)	122	0.47	1.10 to 1.60
24AWG (Stranded Wire)	132	0.37	1.10 to 1.60

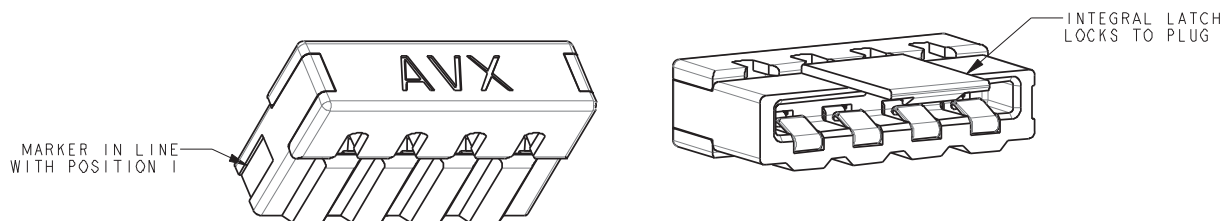

## PACKING DETAILS CAP AND CONNECTOR SUPPLIED TOGETHER (2 PARTS)

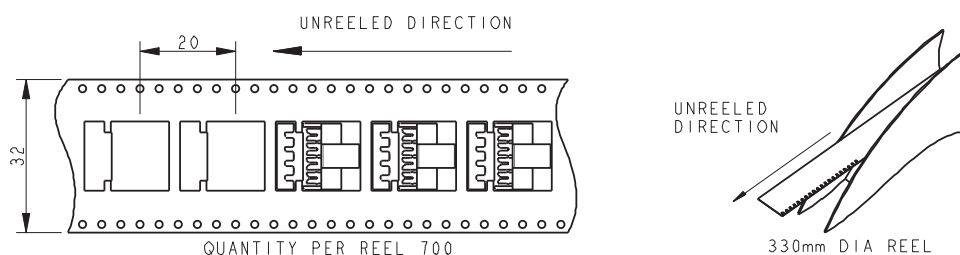

# IDC Socket: WTB Through Wire Cap/Wire Stop Cap



Series 24-9159

## SOCKET WIRED – 5 WAY THROUGH WIRE CAP

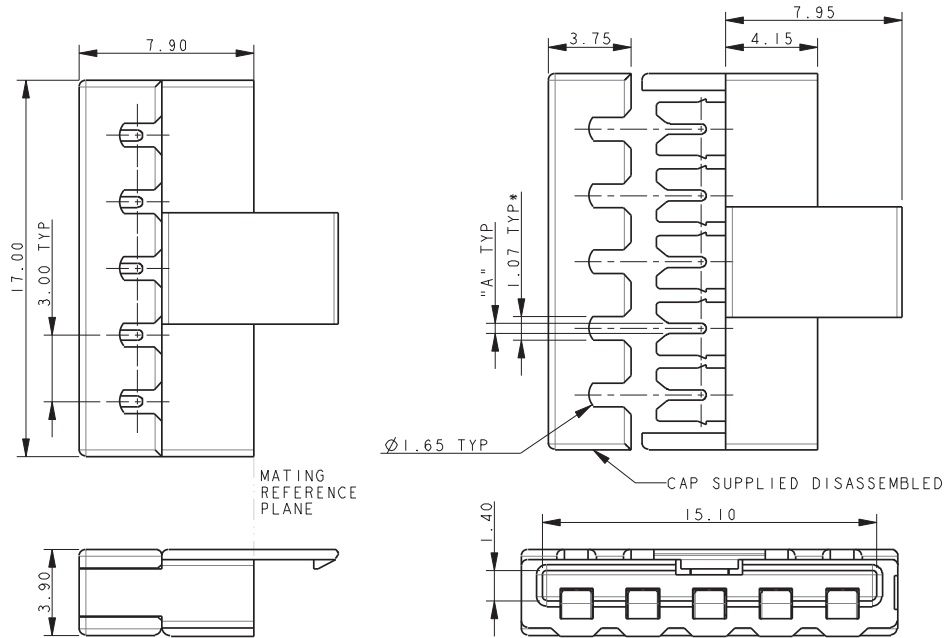

### NOTES:

1. FOR MORE INFORMATION REFER TO PRODUCT SPEC 201-01-119.  
FOR WIRE ASSEMBLY REFER TO APPLICATION NOTES 201-01-123.
2. THROUGH WIRE CAP, FOR TERMINATION OF WIRE IN ANY POSITION.
3. CAP ACTS AS WIRE ASSEMBLY TOOL. WIRE PREFIT TO CAP, NARROW SLOT TO GRIP WIRE, PERMANENT ASSEMBLY.
4. GENERAL TOLERANCE  $\pm 0.20$  UNLESS SPECIFIED.
5. INSULATOR MATERIAL: NYLON 46, GLASS FILLED, UL94 V-0. COLOR REFER TO PAGE 50.
6. CONTACT MATERIAL: COPPER ALLOY, PLATING NICKEL BASE ALL OVER, GOLD ON CONTACT, TIN ON IDC.
7. PACKING IN TAPE AND REEL. QTY PER REEL 700, POCKET CONTAINS 1 CONNECTOR AND 1 CAP.
8. WIRE GAUGE OPTIONS, SEE TABLE.
9. ASSEMBLY AIDS, REFER TO PAGE 61.

Wire Gauge	Code (Page 50)	Dimension A	Wire Insulation Diameter
22AWG (Stranded Wire)	122	0.47	1.10 to 1.60
24AWG (Stranded Wire)	132	0.37	1.10 to 1.60

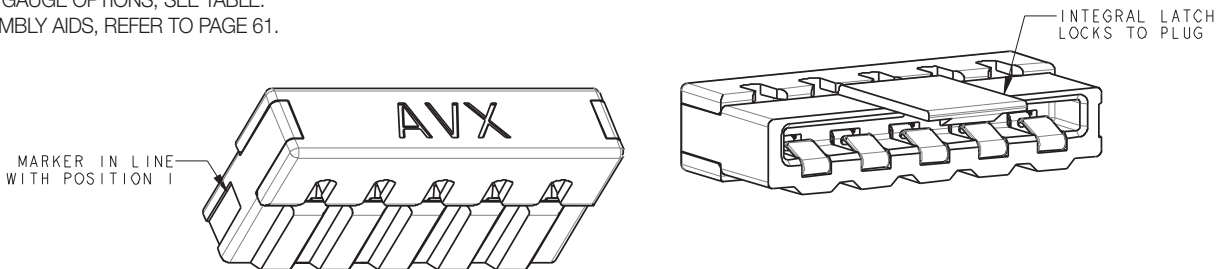

## PACKING DETAILS CAP AND CONNECTOR SUPPLIED TOGETHER (2 PARTS)

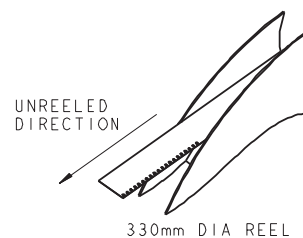
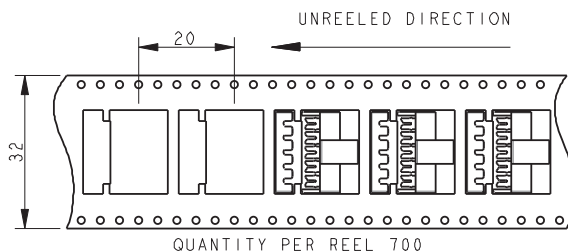



# IDC Socket: WTB Through Wire Cap/Wire Stop Cap



Series 24-9159

## SOCKET WIRED – 6 WAY THROUGH WIRE CAP

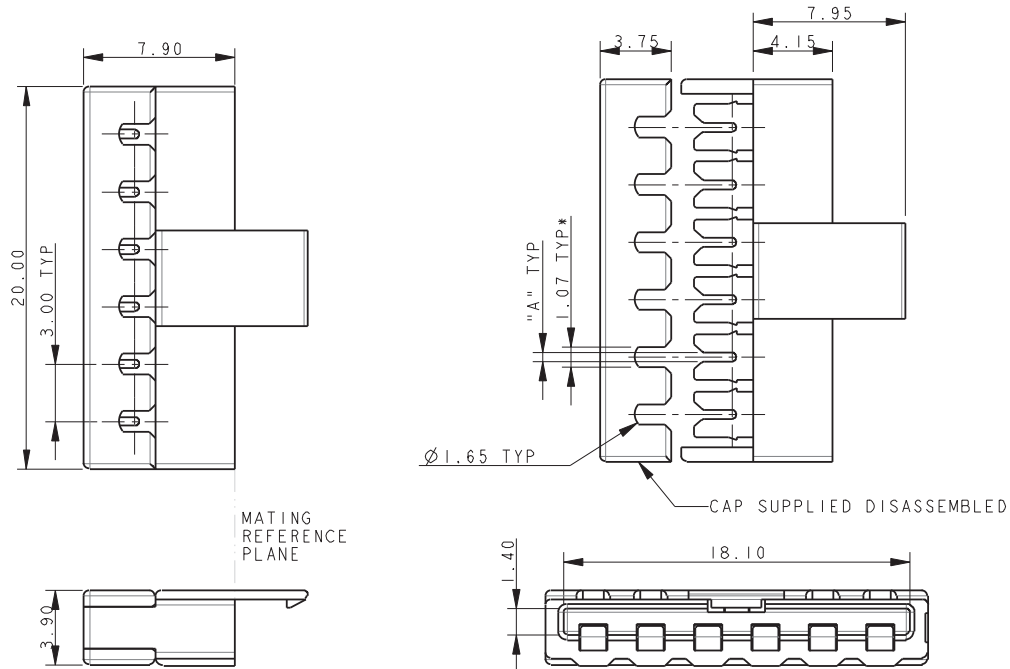

**NOTES:**

1. FOR MORE INFORMATION REFER TO PRODUCT SPEC 201-01-119.  
FOR WIRE ASSEMBLY REFER TO APPLICATION NOTES 201-01-123.
2. THROUGH WIRE CAP, FOR TERMINATION OF WIRE IN ANY POSITION.
3. CAP ACTS AS WIRE ASSEMBLY TOOL. WIRE PREFIT TO CAP, NARROW SLOT TO GRIP WIRE, PERMANENT ASSEMBLY.
4. GENERAL TOLERANCE  $\pm 0.20$  UNLESS SPECIFIED.
5. INSULATOR MATERIAL: NYLON 46, GLASS FILLED, UL94 V-0. COLOR REFER TO PAGE 50.
6. CONTACT MATERIAL: COPPER ALLOY, PLATING NICKEL BASE ALL OVER, GOLD ON CONTACT, TIN ON IDC.
7. PACKING IN TAPE AND REEL. QTY PER REEL 700, POCKET CONTAINS 1 CONNECTOR AND 1 CAP.
8. WIRE GAUGE OPTIONS, SEE TABLE.
9. ASSEMBLY AIDS, REFER TO PAGE 61.

Wire Gauge	Code (Page 50)	Dimension A	Wire Insulation Diameter
22AWG (Stranded Wire)	122	0.47	1.10 to 1.60
24AWG (Stranded Wire)	132	0.37	1.10 to 1.60

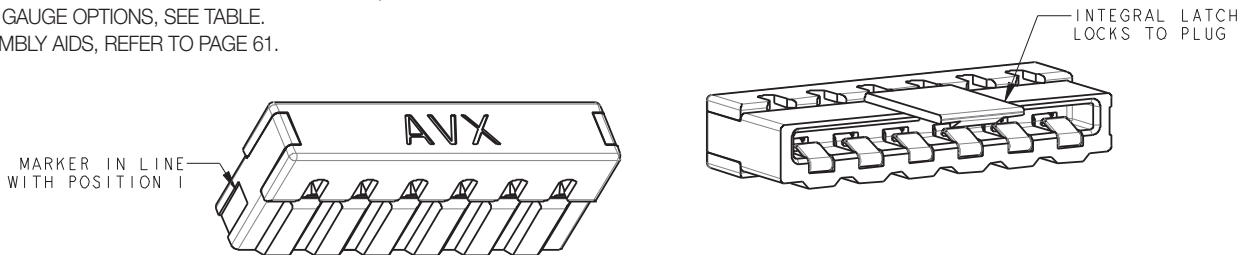

## PACKING DETAILS CAP AND CONNECTOR SUPPLIED TOGETHER (2 PARTS)

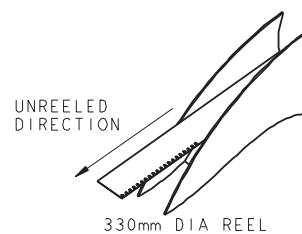
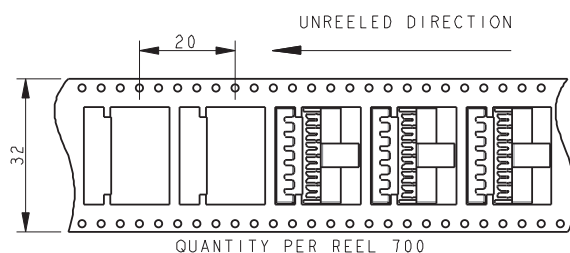

# IDC Socket: WTB Through Wire Cap/Wire Stop Cap



Series 24-9159

## SOCKET-WIRED – 2 WAY WIRE STOP CAP

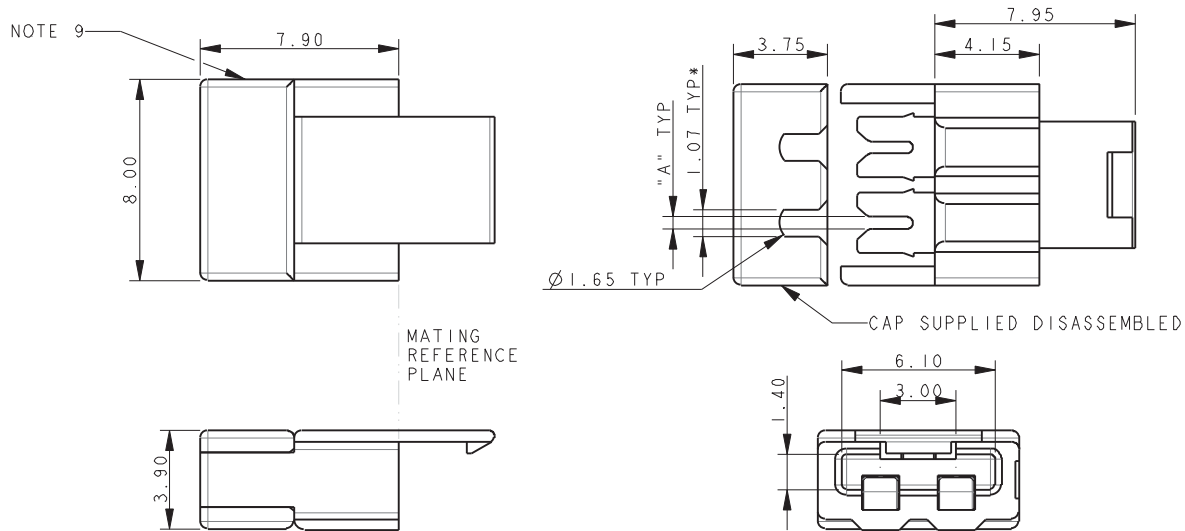

**NOTES:**

1. FOR MORE INFORMATION REFER TO PRODUCT SPEC 201-01-119. FOR WIRE ASSEMBLY REFER TO APPLICATION NOTES 201-01-123.
2. WIRE STOP CAP, WITH STOP FACE ON ONE SIDE TO PROTECT END OF WIRE.
3. CAP ACTS AS WIRE ASSEMBLY TOOL. WIRE PREFIT TO CAP, NARROW SLOT TO GRIP WIRE, PERMANENT ASSEMBLY.
4. GENERAL TOLERANCE  $\pm 0.20$  UNLESS SPECIFIED.
5. INSULATOR MATERIAL: NYLON 46, GLASS FILLED, UL94 V-0. COLOR REFER TO PAGE 50.
6. CONTACT MATERIAL: COPPER ALLOY, PLATING NICKEL BASE ALL OVER, GOLD ON CONTACT, TIN ON IDC.
7. PACKING IN TAPE AND REEL. QTY PER REEL 700, POCKET CONTAINS 1 CONNECTOR AND 1 CAP.
8. WIRE GAUGE OPTIONS, SEE TABLE.
9. SHOWN WITH WIRE ENTRY FROM UNDERSIDE, CAP CAN BE ASSEMBLED FOR EITHER TOP OR UNDERSIDE WIRE ENTRY.
10. ASSEMBLY AIDS, REFER TO PAGE 61.

Wire Gauge	Code (Page 50)	Dimension A	Wire Insulation Diameter
22AWG (Stranded Wire)	122	0.47	1.10 to 1.60
24AWG (Stranded Wire)	132	0.37	1.10 to 1.60

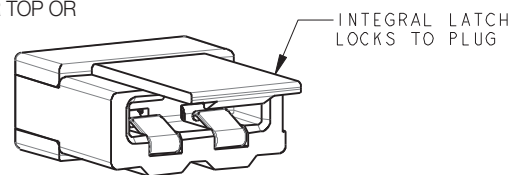
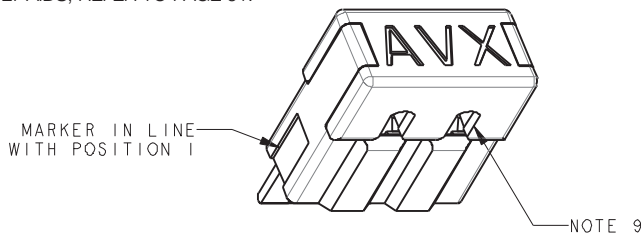

## PACKING DETAILS CAP AND CONNECTOR SUPPLIED TOGETHER (2 PARTS)

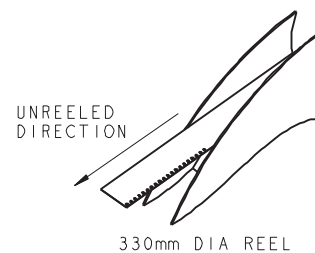
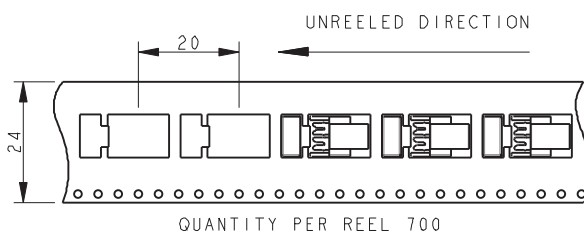

# IDC Socket: WTB Through Wire Cap/Wire Stop Cap



Series 24-9159

## SOCKET-WIRED – 3 WAY WIRE STOP CAP

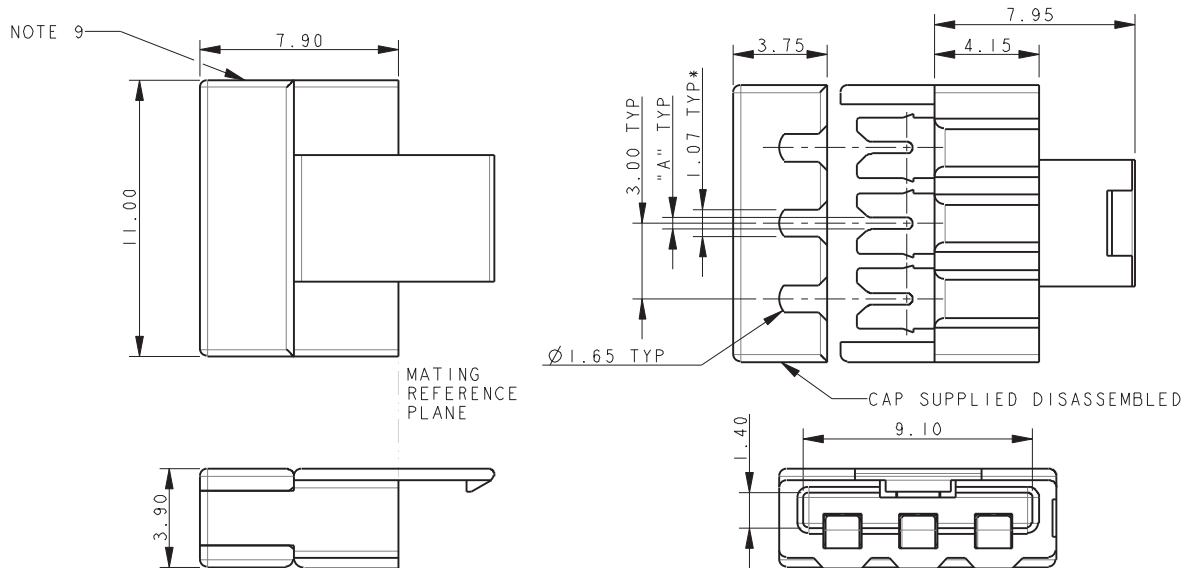

**NOTES:**

1. FOR MORE INFORMATION REFER TO PRODUCT SPEC 201-01-119. FOR WIRE ASSEMBLY REFER TO APPLICATION NOTES 201-01-123.
2. WIRE STOP CAP, WITH STOP FACE ON ONE SIDE TO PROTECT END OF WIRE.
3. CAP ACTS AS WIRE ASSEMBLY TOOL. WIRE PREFIT TO CAP, NARROW SLOT TO GRIP WIRE, PERMANENT ASSEMBLY.
4. GENERAL TOLERANCE  $\pm 0.20$  UNLESS SPECIFIED.
5. INSULATOR MATERIAL: NYLON 46, GLASS FILLED, UL94 V-0. COLOR REFER TO PAGE 50.
6. CONTACT MATERIAL: COPPER ALLOY, PLATING NICKEL BASE ALL OVER, GOLD ON CONTACT, TIN ON IDC.
7. PACKING IN TAPE AND REEL. QTY PER REEL 700, POCKET CONTAINS 1 CONNECTOR AND 1 CAP.
8. WIRE GAUGE OPTIONS, SEE TABLE.
9. SHOWN WITH WIRE ENTRY FROM UNDERSIDE, CAP CAN BE ASSEMBLED FOR EITHER TOP OR UNDERSIDE WIRE ENTRY.
10. ASSEMBLY AIDS, REFER TO PAGE 61.

Wire Gauge	Code (Page 50)	Dimension A	Wire Insulation Diameter
22AWG (Stranded Wire)	122	0.47	1.10 to 1.60
24AWG (Stranded Wire)	132	0.37	1.10 to 1.60

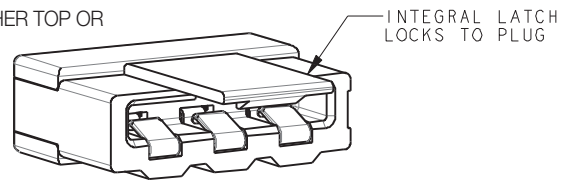
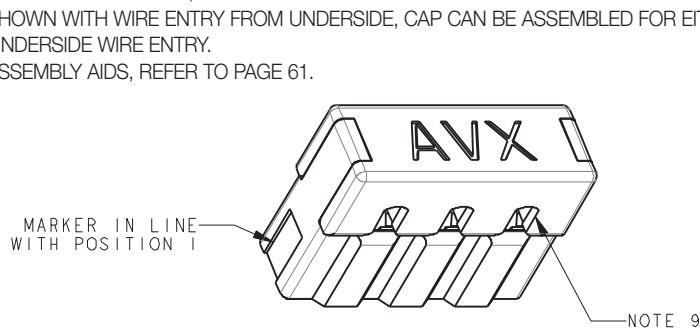

## PACKING DETAILS CAP AND CONNECTOR SUPPLIED TOGETHER (2 PARTS)

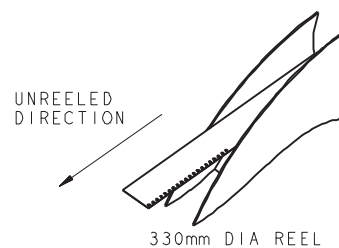
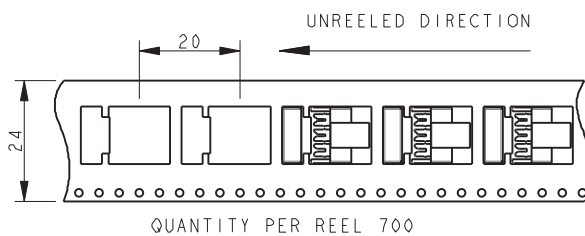

# IDC Socket: WTB Through Wire Cap/Wire Stop Cap



Series 24-9159

## SOCKET-WIRED – 4 WAY WIRE STOP CAP

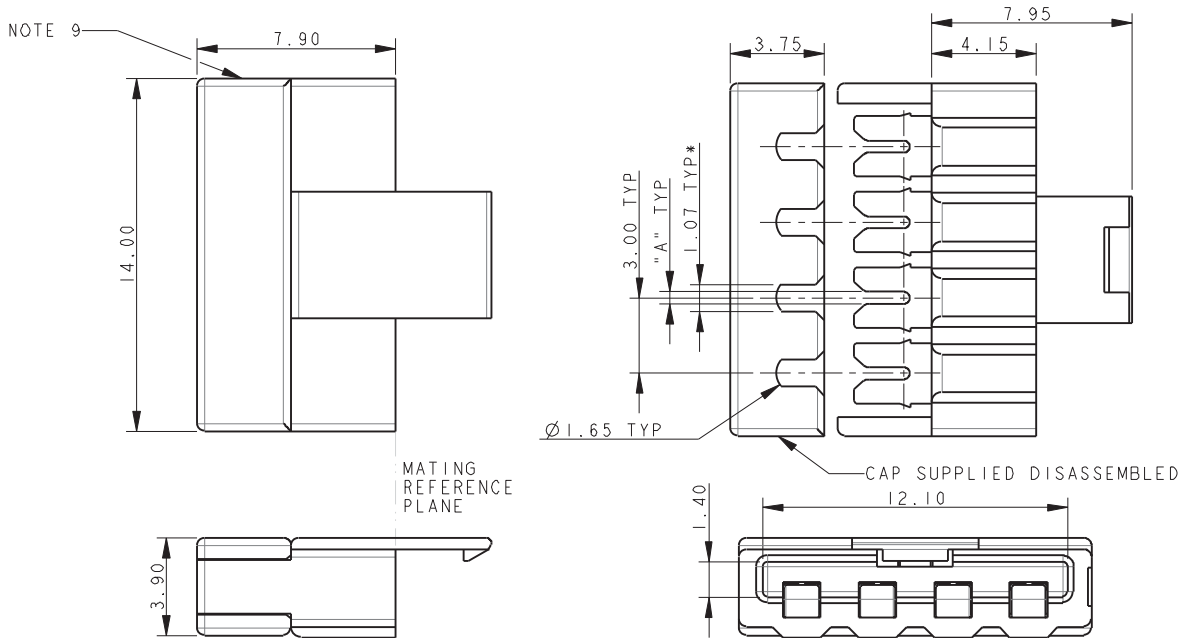

**NOTES:**

- FOR MORE INFORMATION REFER TO PRODUCT SPEC 201-01-119.  
FOR WIRE ASSEMBLY REFER TO APPLICATION NOTES 201-01-123.
- WIRE STOP CAP, WITH STOP FACE ON ONE SIDE TO PROTECT END OF WIRE.
- CAP ACTS AS WIRE ASSEMBLY TOOL. WIRE PREFIT TO CAP, NARROW SLOT TO GRIP WIRE, PERMANENT ASSEMBLY.
- GENERAL TOLERANCE  $\pm 0.20$  UNLESS SPECIFIED.
- INSULATOR MATERIAL: NYLON 46, GLASS FILLED, UL94 V-0. COLOR REFER TO PAGE 50.
- CONTACT MATERIAL: COPPER ALLOY, PLATING NICKEL BASE ALL OVER, GOLD ON CONTACT, TIN ON IDC.
- PACKING IN TAPE AND REEL. QTY PER REEL 700, POCKET CONTAINS 1 CONNECTOR AND 1 CAP.
- WIRE GAUGE OPTIONS, SEE TABLE.
- SHOWN WITH WIRE ENTRY FROM UNDERSIDE, CAP CAN BE ASSEMBLED FOR EITHER TOP OR UNDERSIDE WIRE ENTRY.
- ASSEMBLY AIDS, REFER TO PAGE 61.

Wire Gauge	Code (Page 50)	Dimension A	Wire Insulation Diameter
22AWG (Stranded Wire)	122	0.47	1.10 to 1.60
24AWG (Stranded Wire)	132	0.37	1.10 to 1.60

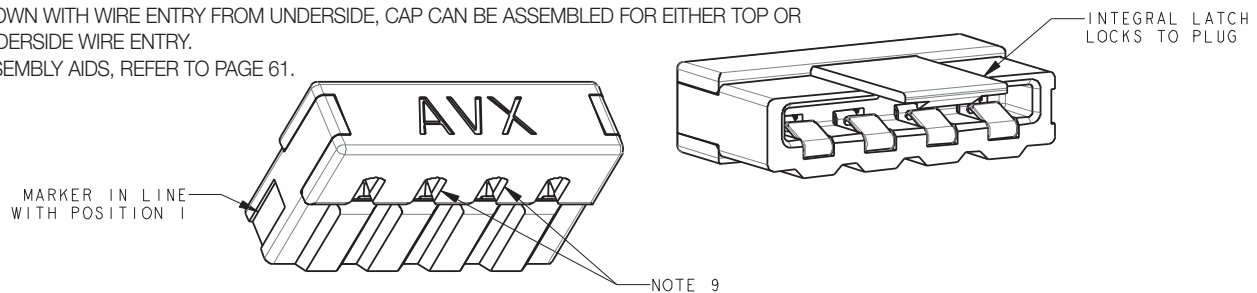

## PACKING DETAILS CAP AND CONNECTOR SUPPLIED TOGETHER (2 PARTS)

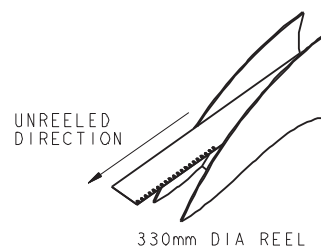
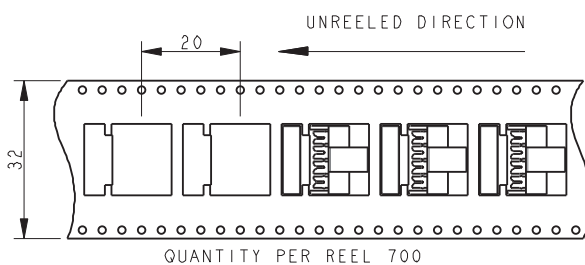

# IDC Socket: WTB

## Through Wire Cap/Wire Stop Cap

### Series 24-9159



### SOCKET-WIRED – 5 WAY WIRE STOP CAP

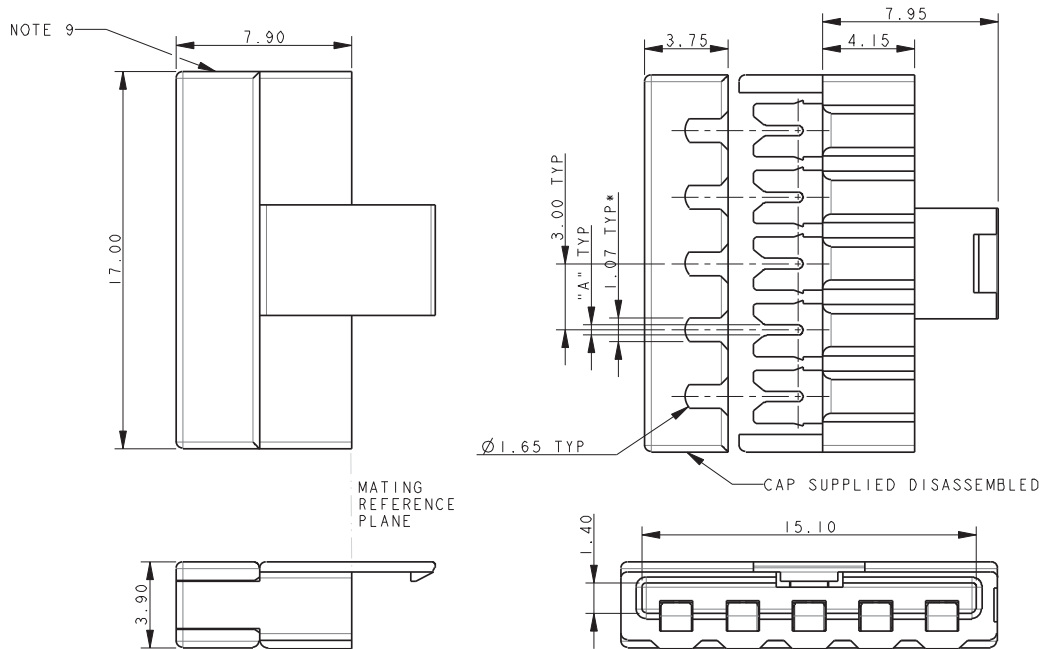

**NOTES:**

1. FOR MORE INFORMATION REFER TO PRODUCT SPEC 201-01-119.  
FOR WIRE ASSEMBLY REFER TO APPLICATION NOTES 201-01-123.
2. WIRE STOP CAP, WITH STOP FACE ON ONE SIDE TO PROTECT END OF WIRE.
3. CAP ACTS AS WIRE ASSEMBLY TOOL. WIRE PREFIT TO CAP, NARROW SLOT TO GRIP WIRE, PERMANENT ASSEMBLY.
4. GENERAL TOLERANCE  $\pm 0.20$  UNLESS SPECIFIED.
5. INSULATOR MATERIAL: NYLON 46, GLASS FILLED, UL94 V-0. COLOR REFER TO PAGE 50.
6. CONTACT MATERIAL: COPPER ALLOY, PLATING NICKEL BASE ALL OVER, GOLD ON CONTACT, TIN ON IDC.
7. PACKING IN TAPE AND REEL. QTY PER REEL 700, POCKET CONTAINS 1 CONNECTOR AND 1 CAP.
8. WIRE GAUGE OPTIONS, SEE TABLE.
9. SHOWN WITH WIRE ENTRY FROM UNDERSIDE, CAP CAN BE ASSEMBLED FOR EITHER TOP OR UNDERSIDE WIRE ENTRY.
10. ASSEMBLY AIDS, REFER TO PAGE 61.

Wire Gauge	Code (Page 50)	Dimension A	Wire Insulation Diameter
22AWG (Stranded Wire)	122	0.47	1.10 to 1.60
24AWG (Stranded Wire)	132	0.37	1.10 to 1.60

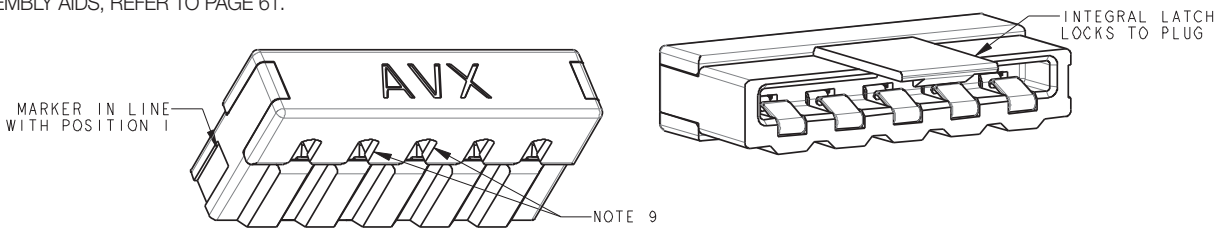

### PACKING DETAILS

#### CAP AND CONNECTOR SUPPLIED TOGETHER (2 PARTS)

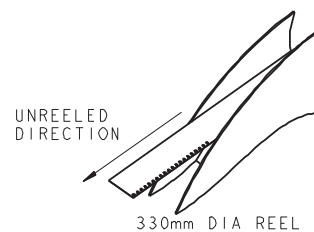
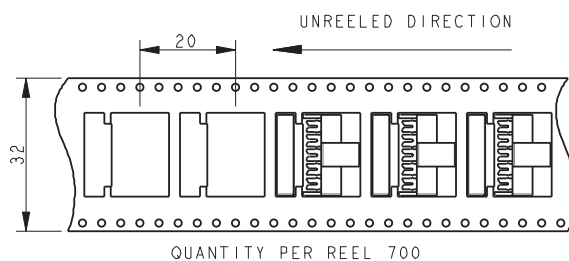

# IDC Socket: WTB

## Through Wire Cap/Wire Stop Cap

### Series 24-9159



### SOCKET-WIRED – 6 WAY WIRE STOP CAP

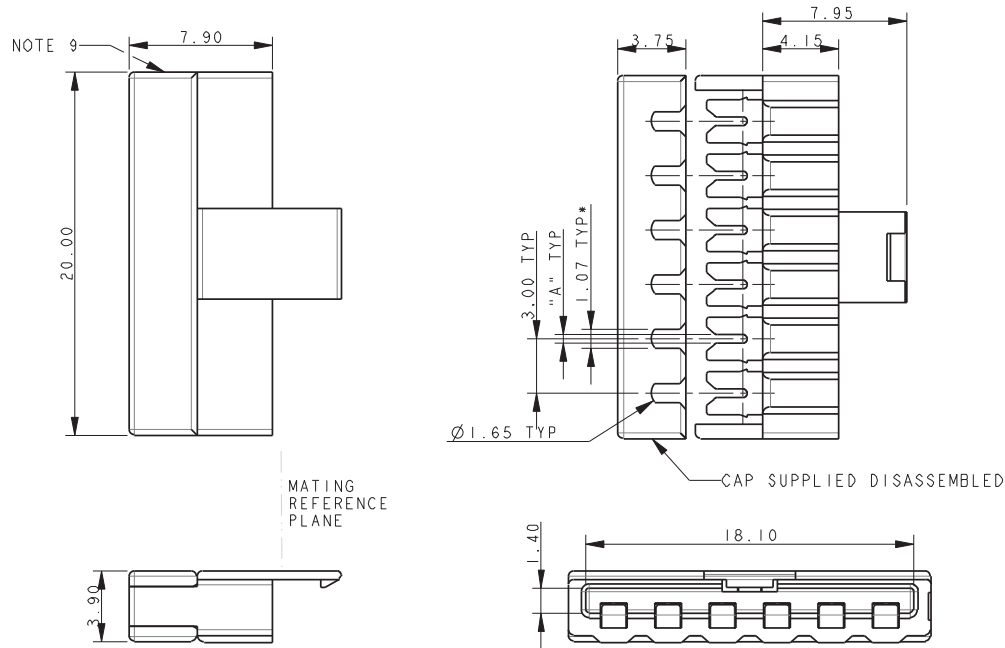

#### NOTES:

- FOR MORE INFORMATION REFER TO PRODUCT SPEC 201-01-119. FOR WIRE ASSEMBLY REFER TO APPLICATION NOTES 201-01-123.
- WIRE STOP CAP, WITH STOP FACE ON ONE SIDE TO PROTECT END OF WIRE.
- CAP ACTS AS WIRE ASSEMBLY TOOL. WIRE PREFIT TO CAP, NARROW SLOT TO GRIP WIRE, PERMANENT ASSEMBLY.
- GENERAL TOLERANCE  $\pm 0.20$  UNLESS SPECIFIED.
- INSULATOR MATERIAL: NYLON 46, GLASS FILLED, UL94 V-0. COLOR REFER TO PAGE 50.
- CONTACT MATERIAL: COPPER ALLOY, PLATING NICKEL BASE ALL OVER, GOLD ON CONTACT, TIN ON IDC.
- PACKING IN TAPE AND REEL. QTY PER REEL 700, POCKET CONTAINS 1 CONNECTOR AND 1 CAP.
- WIRE GAUGE OPTIONS, SEE TABLE.
- SHOWN WITH WIRE ENTRY FROM UNDERSIDE, CAP CAN BE ASSEMBLED FOR EITHER TOP OR UNDERSIDE WIRE ENTRY.
- ASSEMBLY AIDS, REFER TO PAGE 61.

Wire Gauge	Code (Page 50)	Dimension A	Wire Insulation Diameter
22AWG (Stranded Wire)	122	0.47	1.10 to 1.60
24AWG (Stranded Wire)	132	0.37	1.10 to 1.60

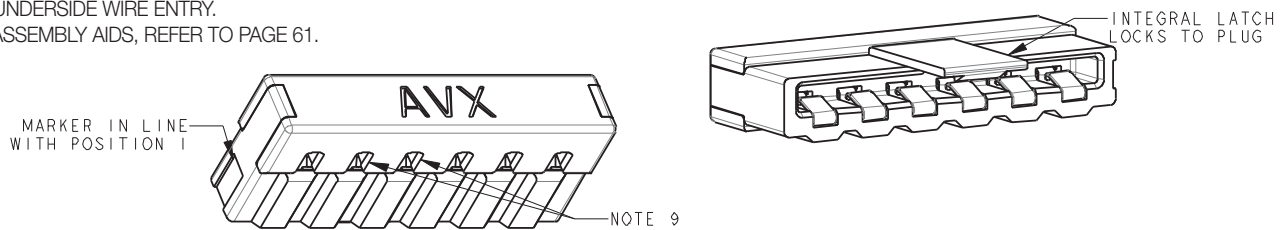

### PACKING DETAILS

#### CAP AND CONNECTOR SUPPLIED TOGETHER (2 PARTS)

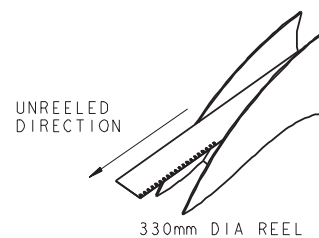
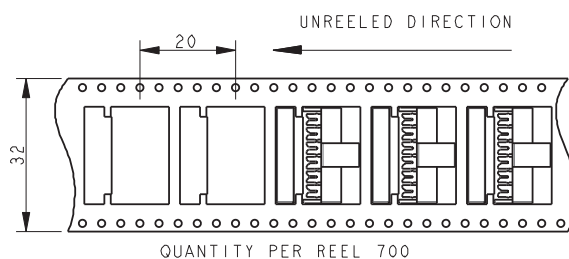

# IDC Socket: WTB Through Wire Cap/Wire Stop Cap

Series 24-9159

## SOCKET-WIRED – ASSEMBLY SUPPORT BLOCK

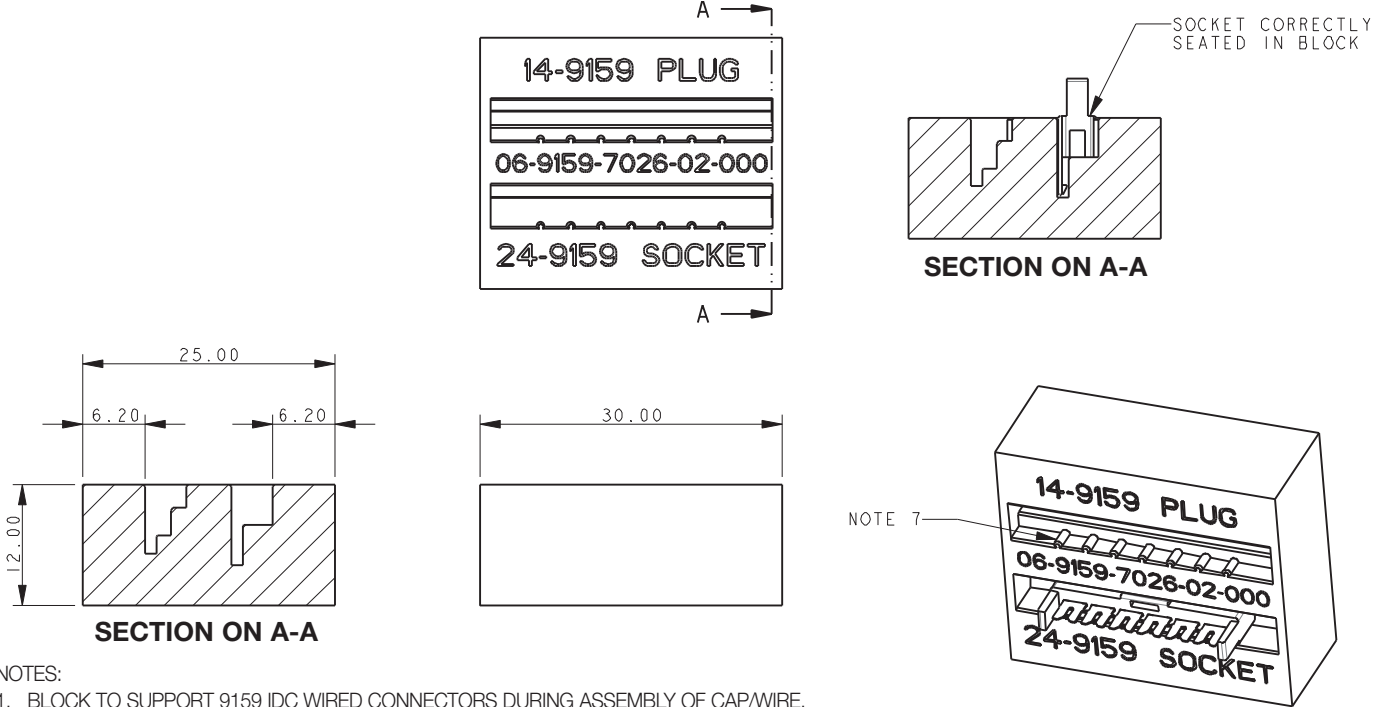

- NOTES:
1. BLOCK TO SUPPORT 9159 IDC WIRED CONNECTORS DURING ASSEMBLY OF CAP/WIRE.
  2. PART NUMBER 06-9159-7026-01-000, MATERIAL ALUMINUM.  
PART NUMBER 06-9159-7026-02-000, MATERIAL NYLON 46.
  3. CAN BE USED WITH EITHER THE PLUG OR SOCKET CONNECTORS, USE THE CORRECT SLOT AS IDENTIFIED.
  4. FOR FULL WIRE ASSEMBLY DETAILS REFER TO APPLICATION NOTES 201-01-123.
  5. ONLY A SIMPLE FLAT BOTTOMED TOOL REQUIRED TO PUSH THE CAP DOWN (NOT SUPPLIED.)
  6. ALL DIMENSIONS  $\pm 0.20$  UNLESS TOLERANCED.
  7. 06-9159-7026-02-000 HAS RIBS TO HELP LOCATE CONTACT/INSULATOR SUB-ASSEMBLY.

## SOCKET-WIRED – WIRE INSERTION TOOL

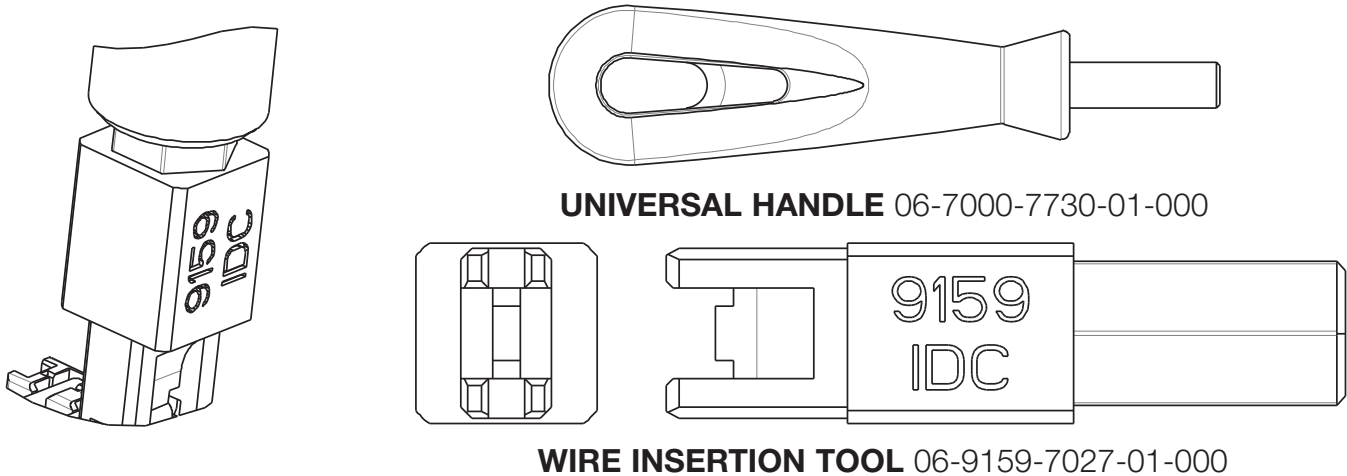

- NOTES:
1. TOOL 06-9159-7027-01-000 TO INSERT WIRES INTO CAP.
  2. FOR USE WITH UNIVERSAL HANDLE 06-7000-7720-01-000.
  3. CAN BE USED WITH BOTH THROUGH WIRE AND WIRE STOP CAPS.
  4. REFER TO APPLICATION NOTES 201-01-123 FOR FURTHER DETAILS.

# IDC Socket: WTB Through Wire Cap/Wire Stop Cap



Series 24-9159

## SOCKET-WIRED – ASSEMBLY

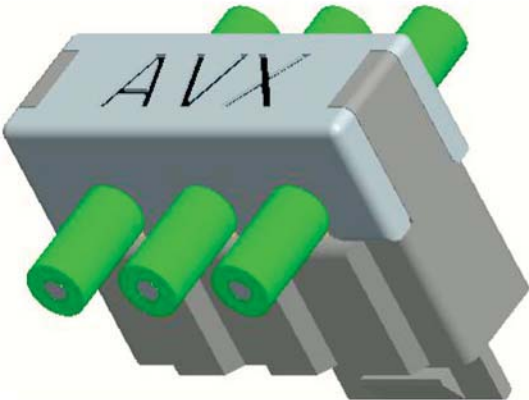

**THROUGH WIRE**

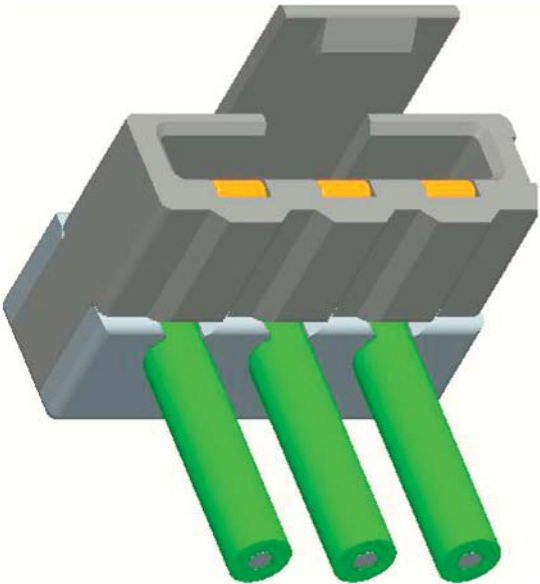

**WIRED STOP  
WIRE ENTRY UNDERSIDE**

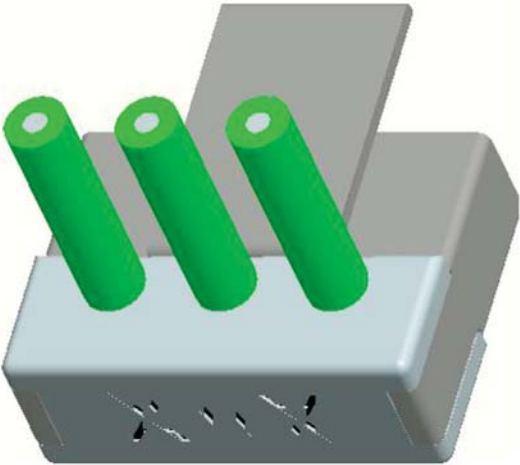

**WIRED STOP  
WIRE ENTRY TOP**





# SSL – Shorting Socket



## Series 58-9159

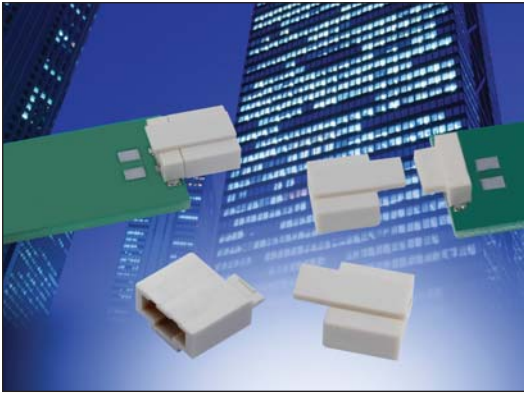

The 9159 series of Board-to-Board interconnect system allows two PCB's to be mated end-to-end creating strips of LED lighting. Designed specifically for the unique Solid State Lighting (SSL) market requiring coplanar (horizontal-to-horizontal) PCB mating with a 5 Amp current rating in the smallest package available. The 2 position shorting socket was designed to plug onto the last PCB in the lighting strip to short the two contacts together, closing the electrical loop. Just as the cabled plug brings power and signals onto the light strip, the shorting socket completes the circuit while maintaining a single board design.

### APPLICATIONS

- Coplanar PCB mating in SSL products
- LED linear lighting strips
- Application Notes: refer to 201-01-123

### FEATURES AND BENEFITS

- Mates to the standard plug connector: does not require a new connector
- Integral latching mechanism: Provides positive attachment to the plug
- Gold plated BeCu spring contacts: reliability for harsh environments
- Available in white: supports SSL market preferences

### ELECTRICAL

- Current Rating: 5 Amps / Contact
- Voltage Rating: 125 VAC

### ENVIRONMENTAL

- Operating Temperature: -40°C to +125°C

### MECHANICAL

- Insulator Material: Nylon: VL94VO
- Contact Material: BeCu / Phos Bronze
- Plating: Gold / Tin over Nickel
- Durability: 10 Cycles

### HOW TO ORDER

**58 9159 002 000 006**

Certification: UL File #E90723



# SSL – Shorting Socket



Series 58-9159

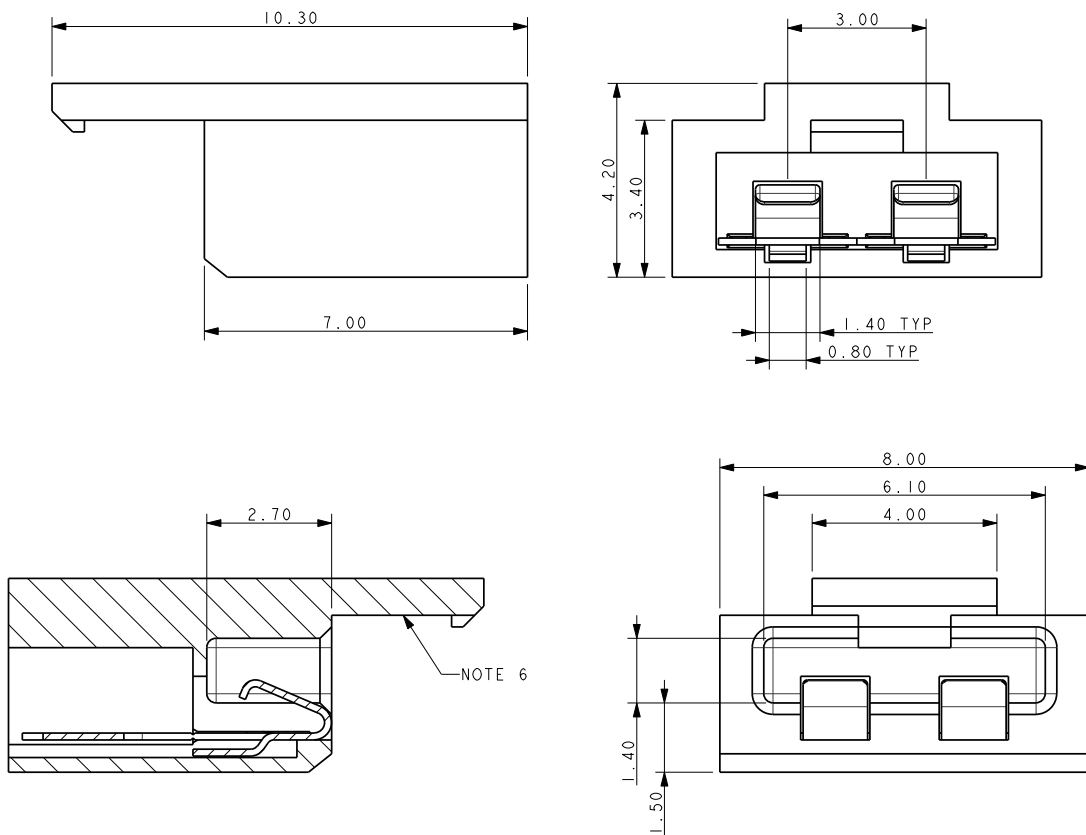
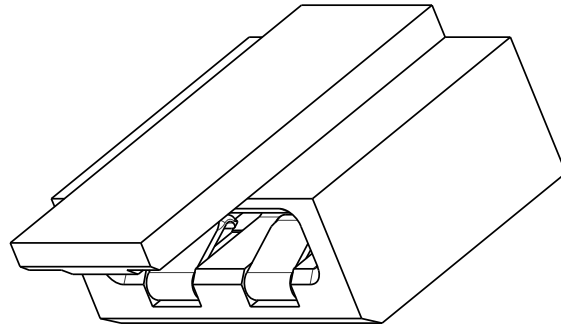

## PACKING DETAILS

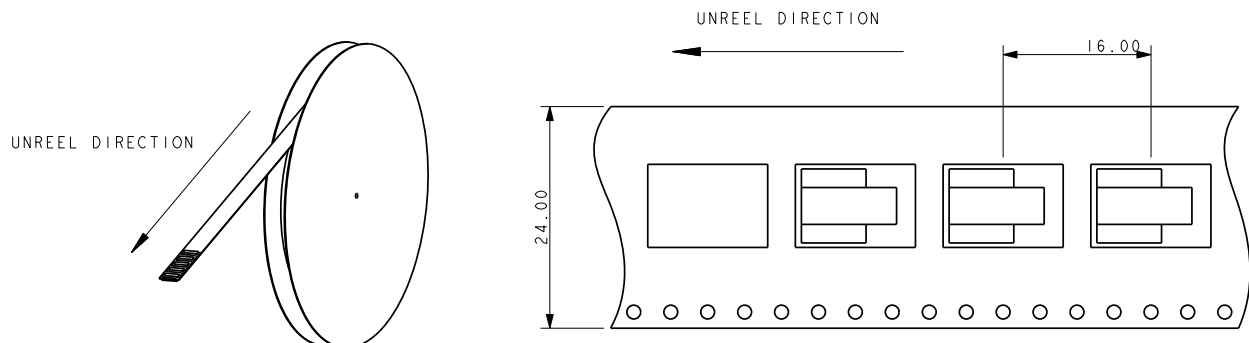

# Coplanar BTB Contact System



## Series 70-9159



Dissecting linear LED lighting from a connector standpoint looks very simple from far away, but up close there is no magical solution. Even though there have been new connectors developed in recent years specifically for this application, the specific requirements in challenging new designs continue to push for something better, different and more cost competitive. AVX has been one of the companies developing new connector systems for this specific application. The 2-Piece 9159 series offers the smallest profile while still supporting full 5 Amp capability. The 1-Piece version offers the best cost advantage for a connectorized solution, yet has limitations in LED pitch densities.

AVX's latest approach is to not even have a connector! LED's run down the center of the board looking to minimize pitch densities to maximize light output. Connectors interrupt this requirement at each Board-to-Board interface. By design and construction, providing a single contact connector is not economical. However, removing the cost of the connector without removing the functionality provides both a technical and cost effective solution. By removing the insulator and allowing contacts to be placed individually, the PCB can be designed with the LED's in the center of the PCB and the contacts on the outer edges. This optimizes the design for functionality and assembly at the best cost possible. More specifically, the contacts are packaged in T&R for automatic placement, absorb significant x and y assembly tolerances and provide a reliable gold-to-gold active contact interface. Application notes are available to outline all of the contact configurations to support both BTB and WTB applications.

### APPLICATIONS

- Linear LED strip lighting
- Commercial/Industrial co-planar or extended card applications
- Reference Product Specification 201-01-149

### FEATURES AND BENEFITS

- Gold plated horizontal contact system maximizes lateral PCB alignment and mating tolerances with a proven 2-pc connector solution
- Contact height has been minimized to 1.2mm above the PCB to prevent any shadowing effect
- Contacts can be individually spaced to support any voltage rating with a full 5 Amp current rating
- Individual contacts can support BTB and WTB applications

### ELECTRICAL

- Current Rating; 5.0 Amps
- Voltage Rating:  
Based on placement distance

### ENVIRONMENTAL

- Operating Temperature:  
-40°C to +125°C

### MECHANICAL

- Contact Material: Copper Alloy
- Plug Plating: Gold in mating area, tin on tails
- Socket Contact; Gold all over
- Durability 5 Cycles

### HOW TO ORDER

<b>70</b>	<b>9159</b>	<b>001</b>	<b>4XX</b>	<b>006</b>
Prefix	Series	Number of Ways 001 = 1	Contact Description 401 = Plug - SMT 402 = Socket - SMT	Packaging Options 006 = Gold in Contact Area

Full details in notes  
pages 66 and 67



# Coplanar BTB Contact System



Series 70-9159

70-9159-001-401-006

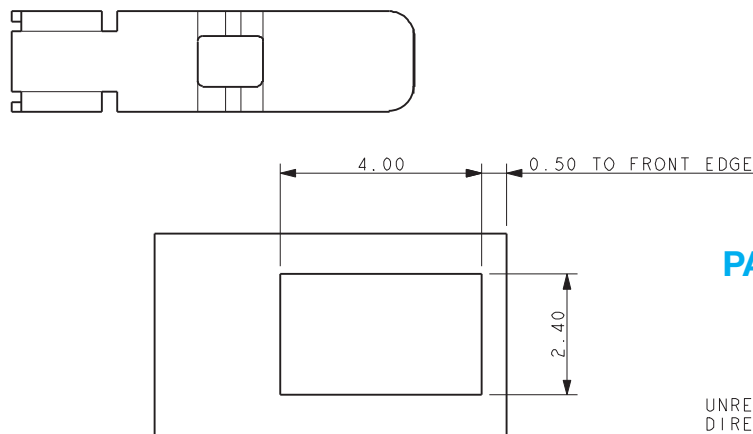
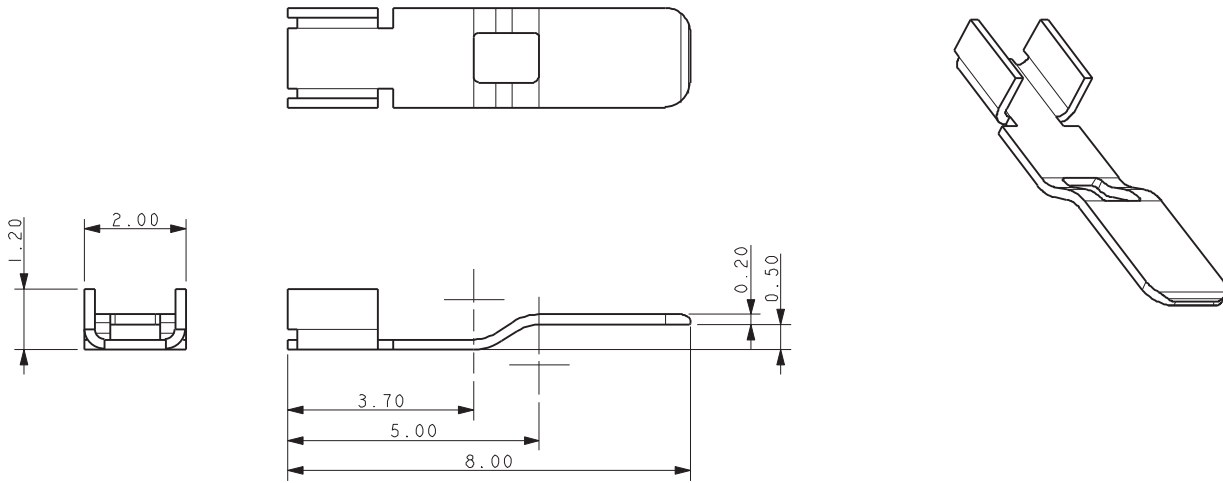

## SUGGESTED PCB LAYOUT

## PACKING DETAILS

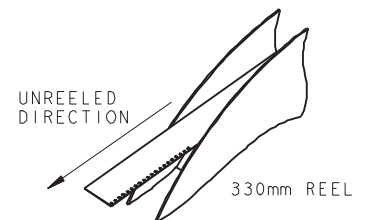

UNREELED DIRECTION

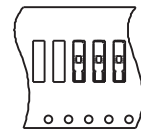

QUANTITY PER REEL TBC

### NOTES:

1. 9159 SINGLE CONTACT, SMT MOUNT, PLUG CONTACT.
2. TO MATE WITH 70-9159-001-402-006 SOCKET CONTACT, REFER TO PAGE 67.
3. TYPICAL APPLICATIONS SEE PAGES 68 AND 69.
4. FOR FURTHER INFORMATION REFER TO SPECIFICATION 201-01-148 AND APPLICATION NOTES 201-01-149.
5. COPPER ALLOY, NICKEL UNDERCOAT, GOLD IN CONTACT AREA. TIN ON SOLDER TAIL.
6. GENERAL TOLERANCE  $\pm 0.20$  UNLESS SPECIFIED.
7. PACKAGING IN TAPE AND REEL, QUANTITY PER REEL 4500.

# Coplanar BTB Contact System



Series 70-9159

70-9159-001-402-006

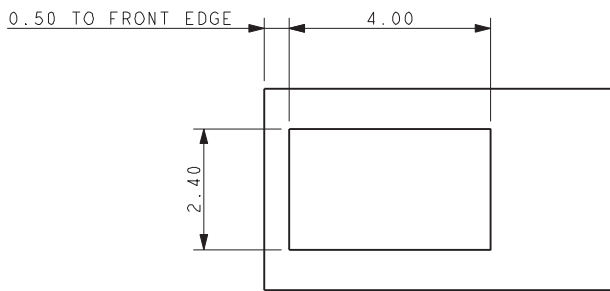
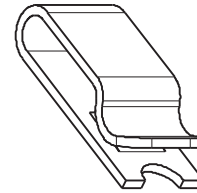
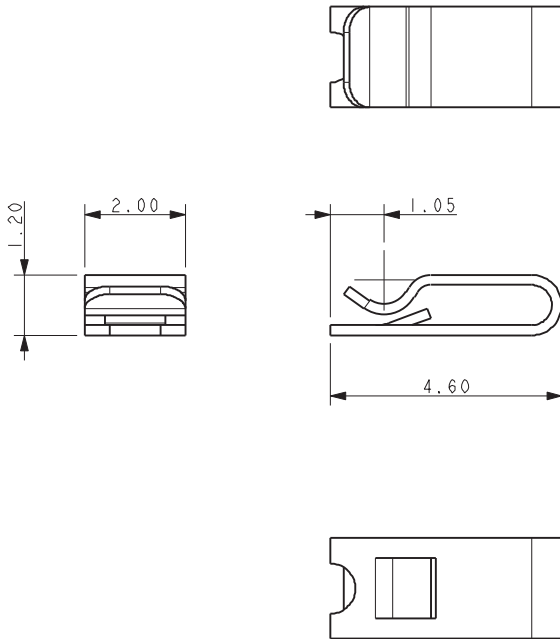

## SUGGESTED PCB LAYOUT

## PACKING DETAILS

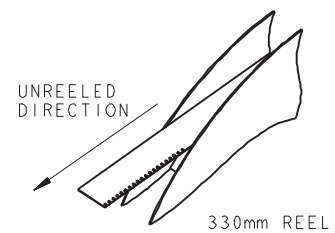

UNREELED DIRECTION

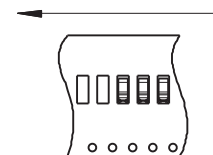

### NOTES:

1. 9159 SINGLE CONTACT, SMT MOUNT, SOCKET CONTACT.
2. TO MATE WITH 70-9159-001-401-006 PLUG CONTACT, REFER TO PAGE 66.
3. TYPICAL APPLICATIONS SEE PAGES 68 AND 69.
4. FOR FURTHER INFORMATION REFER TO SPECIFICATION 201-01-148 AND APPLICATION NOTES 201-01-149.
5. COPPER ALLOY, NICKEL UNDERCOAT, GOLD PLATED.
6. GENERAL TOLERANCE  $\pm 0.20$  UNLESS SPECIFIED.
7. PACKAGING IN TAPE AND REEL, QUANTITY PER REEL 4500.



# Coplanar BTB Contact System



Series 70-9159

70-9159-001-40X-006  
BOARD TO BOARD ASSEMBLY

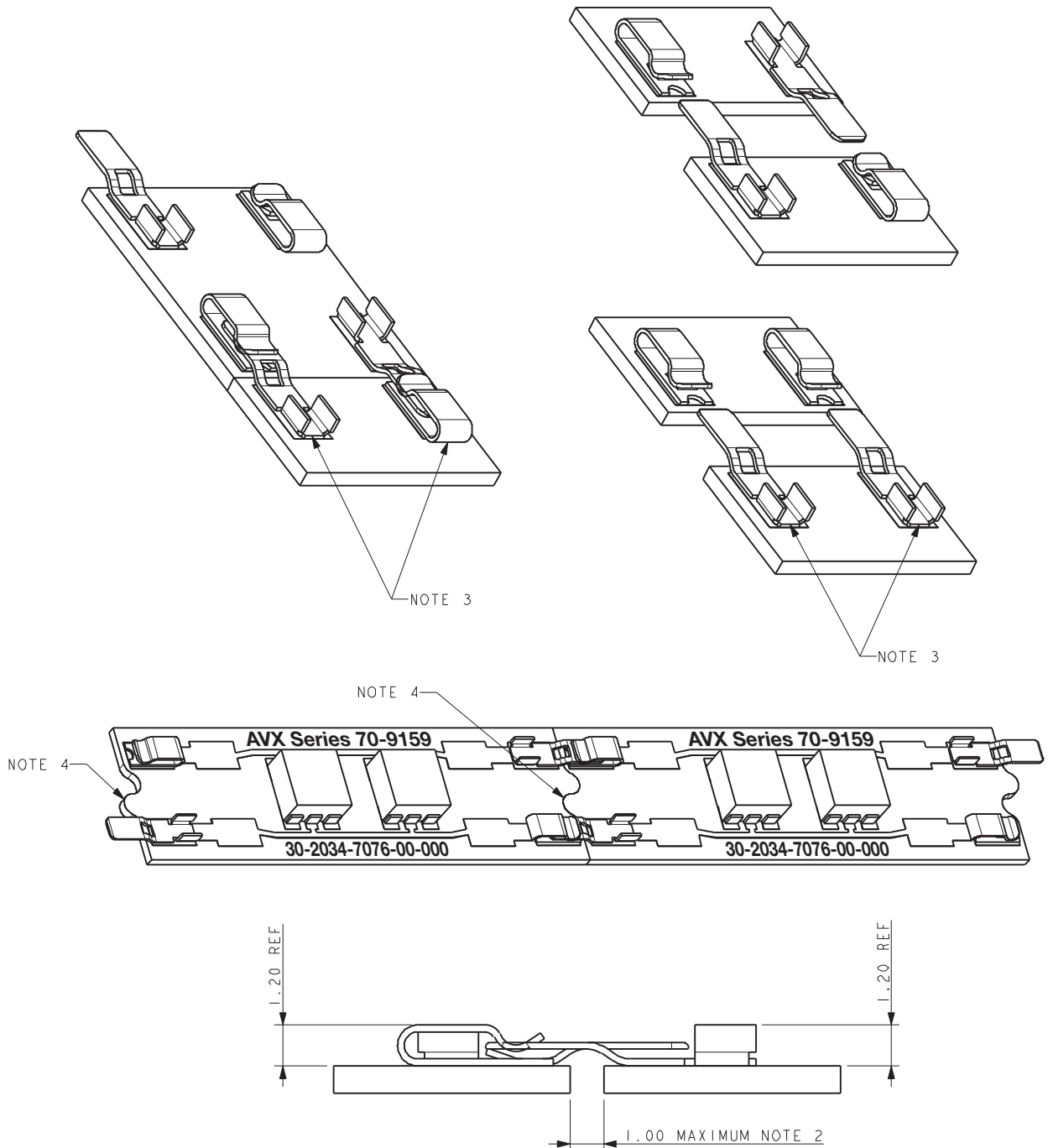

NOTES:

1. SIMPLE BOARD TO BOARD ASSEMBLY
2. CONTACTS WILL COPE WITH A GAP BETWEEN BOARDS UP TO 1.00MM.
3. ALL MATING COMBINATIONS PERMISSIBLE, FOR EXAMPLE BY USING 1 PLUG AND 1 SOCKET ON BOARD E3ND THE BOARDS ARE REVERSABLE.
4. TO AID ALIGNMENT BOARDS MAY BE KEYED TOGETHER.



# Coplanar BTB Contact System



Series 70-9159

## 70-9159-001-40X-006 SIMPLE COMPACT WIRED PLUG ASSEMBLIES

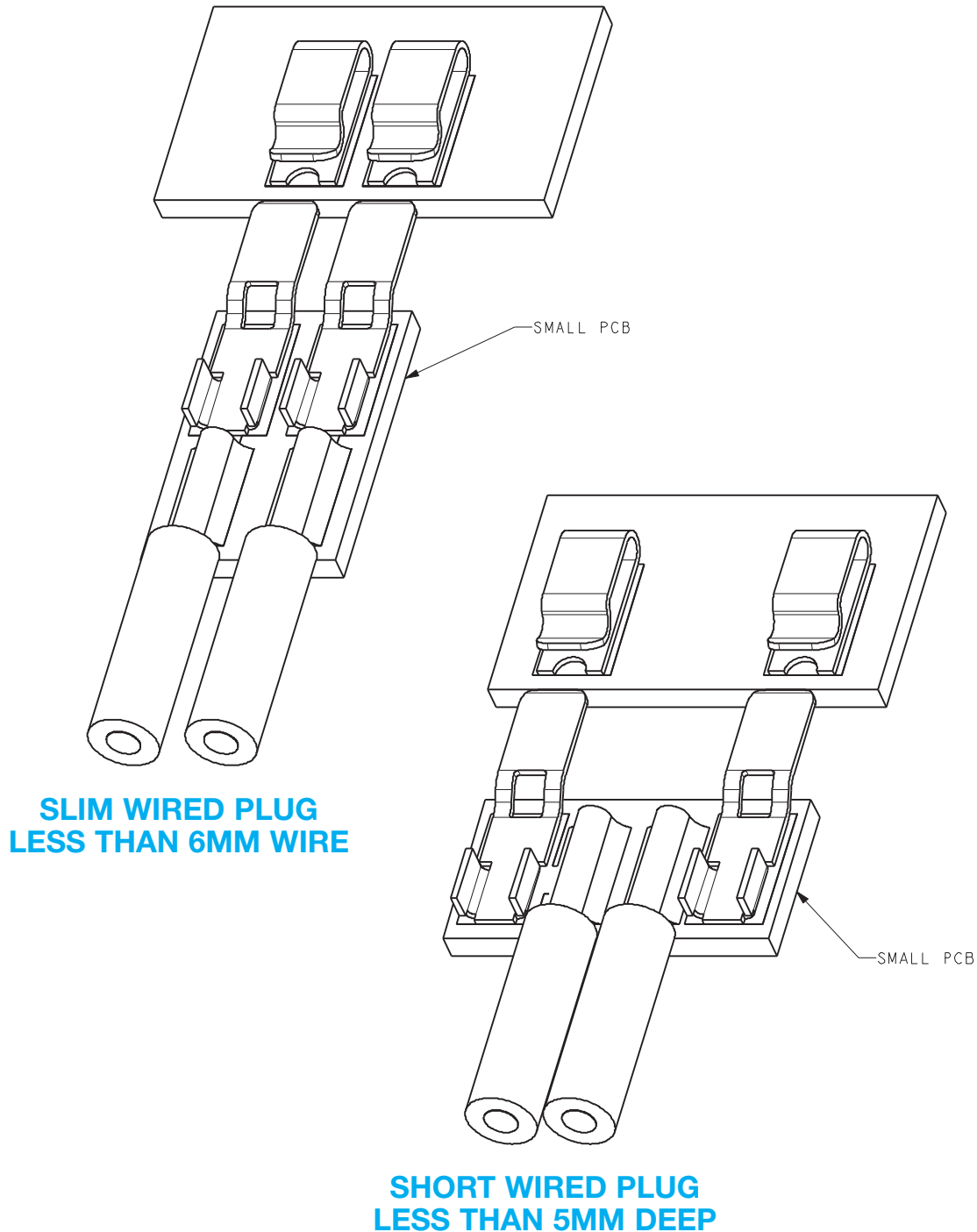

### NOTES:

1. SIMPLE BUILT UP ASSEMBLY
2. CONTACTS CAN BE USED WITH A SUITABLE PCB DESIGN FOR CUSTOMER BUILT SMALL CABLE ASSEMBLIES.
3. TWO WAY PLUG CONNECTIONS SHOWN BUT ANY COMBINATION POSSIBLE.



# One Piece Card Edge

## Series 00-9159

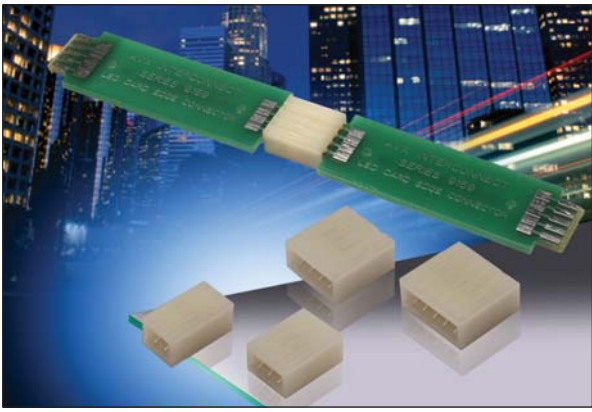

The 9159 series of Board-to-Board interconnect system allows two PCB's to be mated end-to-end creating strips of LED lighting. Designed specifically for the unique Solid State Lighting (SSL) market requiring coplanar (horizontal-to-horizontal) PCB mating. The 1-Piece Card Edge connector was developed to provide a reliable, low cost and simple means of connecting multiple PCB's together. The single stamped contact has dual contact beams to guarantee a high contact force on standard 1.6mm PCB's. These connectors are available in 2 through 5 positions and are on 2.0mm pitch centers to provide a 3 amp continuous rating.

### APPLICATIONS

- Coplanar PCB mating in SSL products
- LED linear lighting strips

### FEATURES AND BENEFITS

- Dual contacts provide positive contact force for enhanced reliability
- Mates with standard  $1.6 \pm 0.15$ mm PCB on 2.0mm pad pitch
- 3 amp current rating for high current applications
- Available in white: supports SSL market preferences

### ELECTRICAL

- Current Rating: 3 Amps / Contact
- Voltage Rating: 250 VAC

### ENVIRONMENTAL

- Operating Temperature:  $-55^{\circ}\text{C}$  to  $+125^{\circ}\text{C}$

### MECHANICAL

- Insulator Material: Nylon 46: UL94HB
- Contact Material: Phosphor Bronze
- Plating: Tin over Nickel
- Durability: 5 Cycles

### HOW TO ORDER

<b>00</b>	<b>9159</b>	<b>XXX</b>	<b>0</b>	<b>01</b>	<b>9</b>	<b>1</b>	<b>6</b>																
Prefix	Series	Number of Ways	Single Part PCB Strip Connector	PCB Thickness	Color Options	Packaging Options	Plating Option																
		<table border="1" style="font-size: small;"> <thead> <tr> <th>Code</th> <th>No of Ways</th> <th>Details</th> </tr> </thead> <tbody> <tr> <td>002</td> <td>2</td> <td>Page 71</td> </tr> <tr> <td>003</td> <td>3</td> <td>Page 72</td> </tr> <tr> <td>004</td> <td>4</td> <td>Page 73</td> </tr> <tr> <td>005</td> <td>5</td> <td>Page 74</td> </tr> </tbody> </table>	Code	No of Ways	Details	002	2		Page 71	003	3	Page 72	004	4	Page 73	005	5	Page 74		01 = $1.60 \pm 0.15$	9 = UL 1 = White	1 = bag 0 = Tape & Reel	06 = Pure Tin all over
Code	No of Ways	Details																					
002	2	Page 71																					
003	3	Page 72																					
004	4	Page 73																					
005	5	Page 74																					

Certification: UL File #E90723





# One Piece Card Edge

Series 00-9159



## 2 WAY SINGLE PART PCB STRIP CONNECTOR

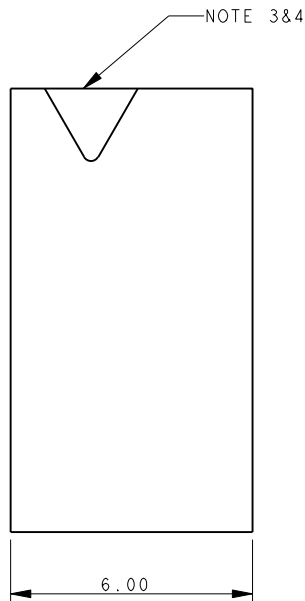
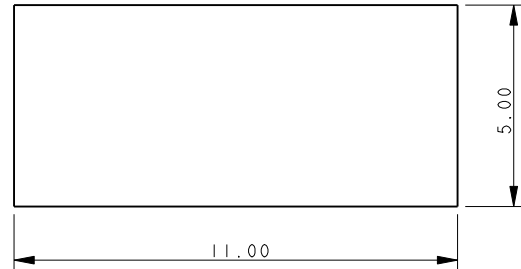
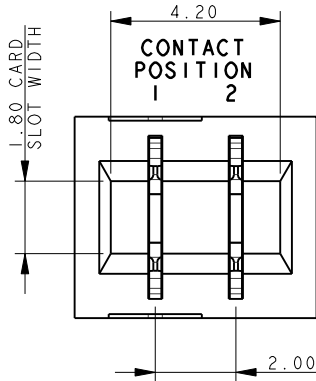

NOTES:

1. FOR MORE INFORMATION REFER TO PRODUCT SPEC 201-01-118.
2. DIMENSIONS ARE REFERENCE DIMENSIONS UNLESS TOLERANCED.
3. ARROW TO INDICATE CONTACT POSITION 1.
4. INSULATOR MATERIAL: NYLON 46, UL94 HB, COLOR SEE PAGE 70.
5. CONTACT MATERIAL: COPPER ALLOY, TIN PLATED ALL OVER.
6. PCB PAD, TIN PLATED.

## 2 WAY PCB BOARD LAYOUT

THICKNESS 1.60 ± 0.15

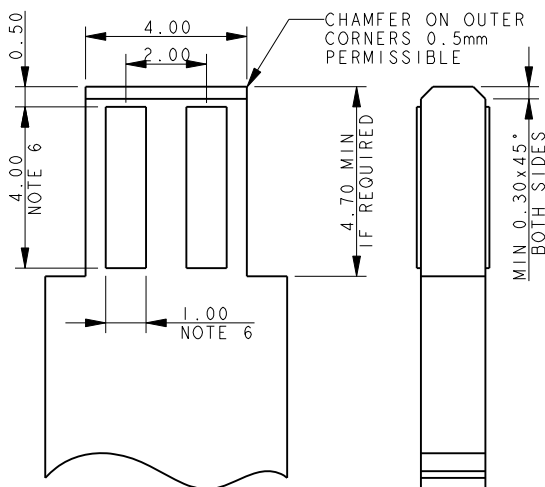

## PACKING DETAILS

REEL QTY	750
LEADER	500MM
TRAILER	500MM
REEL PER BOX	TBC

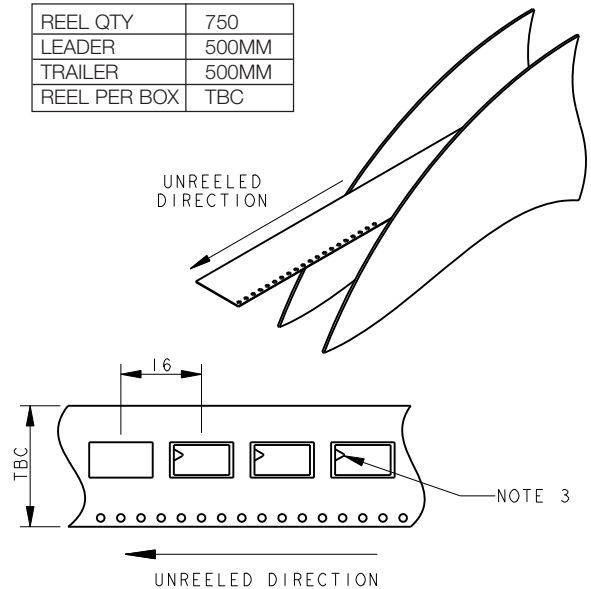

# One Piece Card Edge

Series 00-9159



## 3 WAY SINGLE PART PCB STRIP CONNECTOR

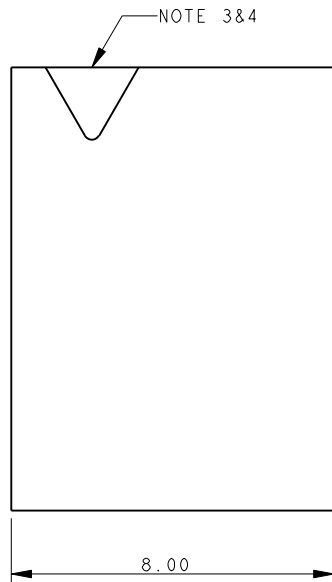
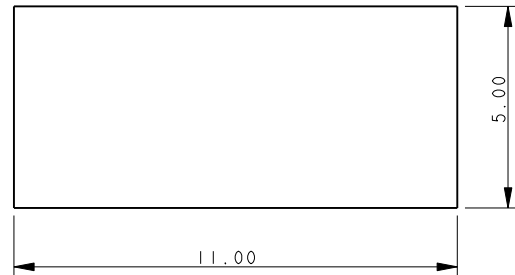
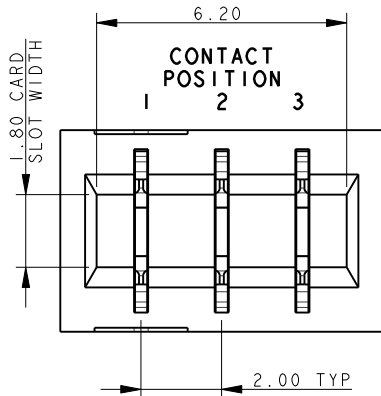

NOTES:

1. FOR MORE INFORMATION REFER TO PRODUCT SPEC 201-01-118.
2. DIMENSIONS ARE REFERENCE DIMENSIONS UNLESS TOLERANCED.
3. ARROW TO INDICATE CONTACT POSITION 1.
4. INSULATOR MATERIAL: NYLON 46, UL94 HB, COLOR SEE PAGE 70.
5. CONTACT MATERIAL: COPPER ALLOY, TIN PLATED ALL OVER.
6. PCB PAD, TIN PLATED.

## 3 WAY PCB BOARD LAYOUT

THICKNESS  $1.60 \pm 0.15$

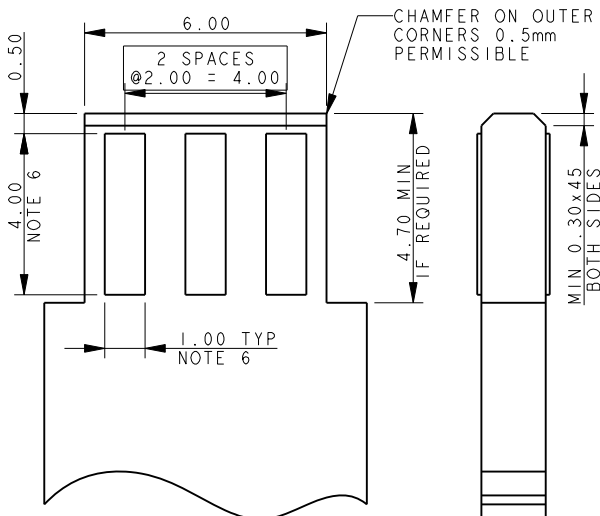

## PACKING DETAILS

REEL QTY	750
LEADER	500MM
TRAILER	500MM
REEL PER BOX	TBC

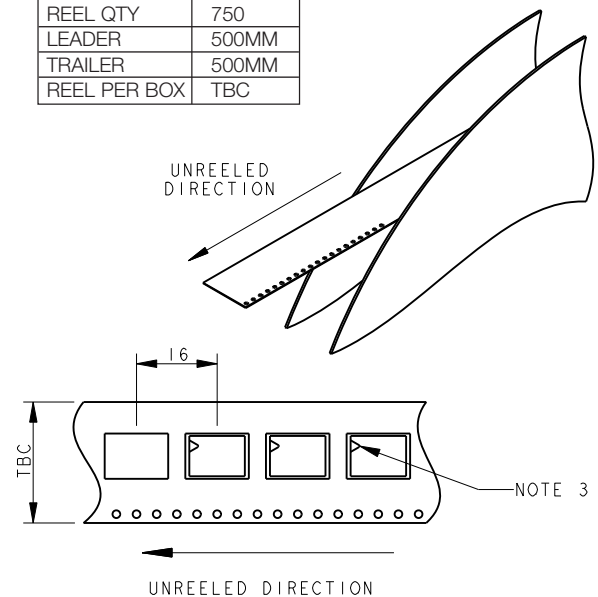

# One Piece Card Edge

Series 00-9159



## 4 WAY SINGLE PART PCB STRIP CONNECTOR

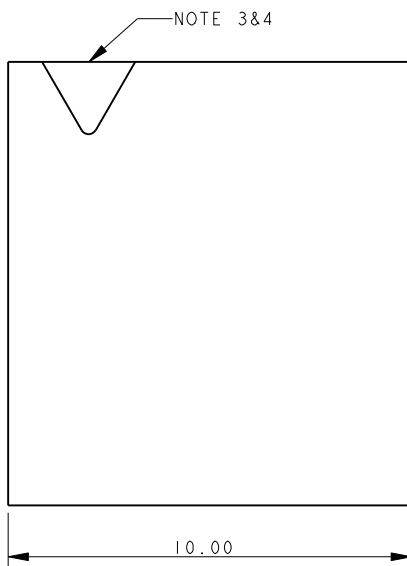
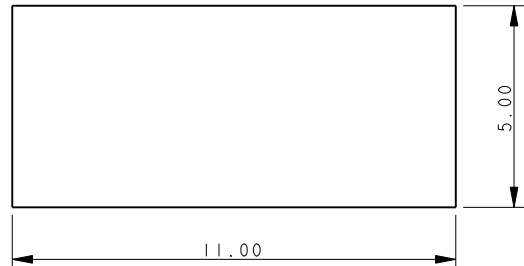
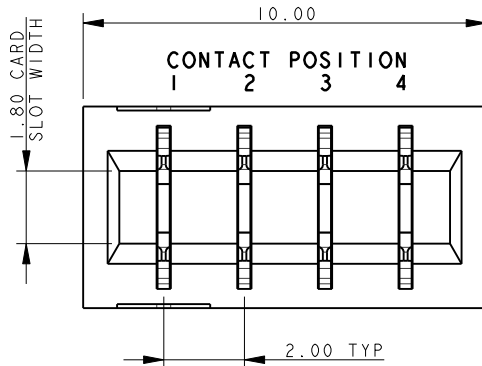

### NOTES:

1. FOR MORE INFORMATION REFER TO PRODUCT SPEC 201-01-118.
2. DIMENSIONS ARE REFERENCE DIMENSIONS UNLESS TOLERANCED.
3. ARROW TO INDICATE CONTACT POSITION 1.
4. INSULATOR MATERIAL: NYLON 46, UL94 HB, COLOR SEE PAGE 70.
5. CONTACT MATERIAL: COPPER ALLOY, TIN PLATED ALL OVER.
6. PCB PAD, TIN PLATED.

## 4 WAY PCB BOARD LAYOUT

THICKNESS  $1.60 \pm 0.15$

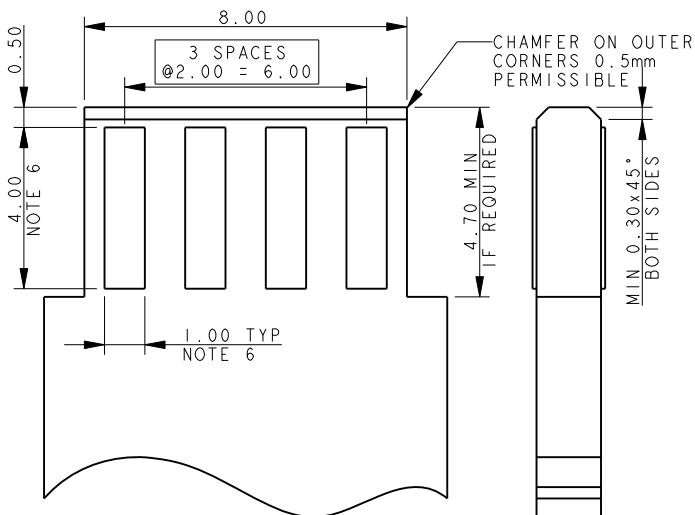

## PACKING DETAILS

REEL QTY	750
LEADER	500MM
TRAILER	500MM
REEL PER BOX	TBC

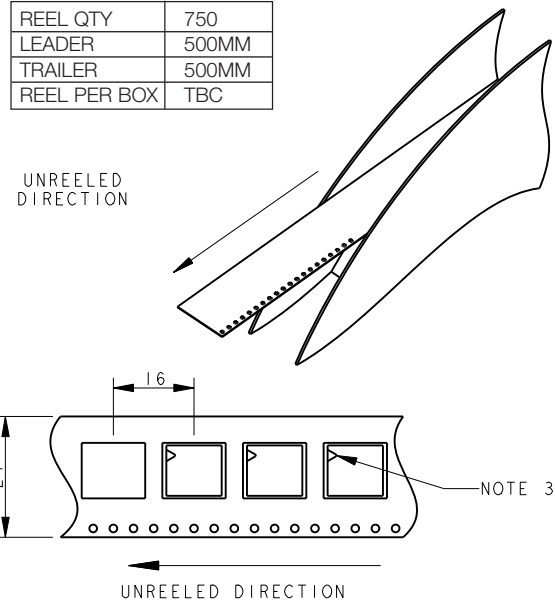

# One Piece Card Edge



Series 00-9159

## 5 WAY SINGLE PART PCB STRIP CONNECTOR

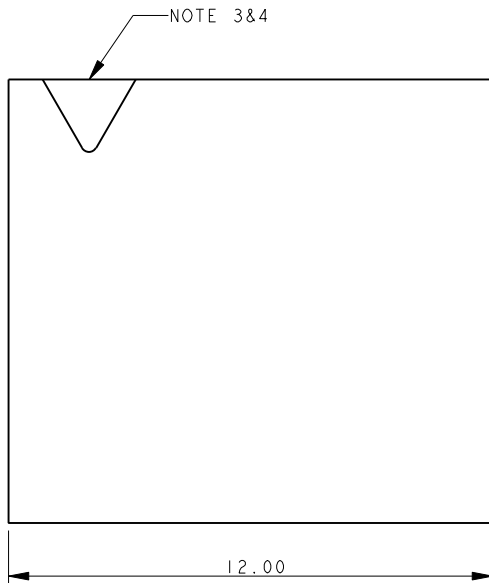
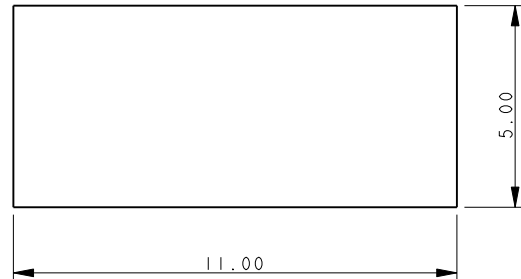
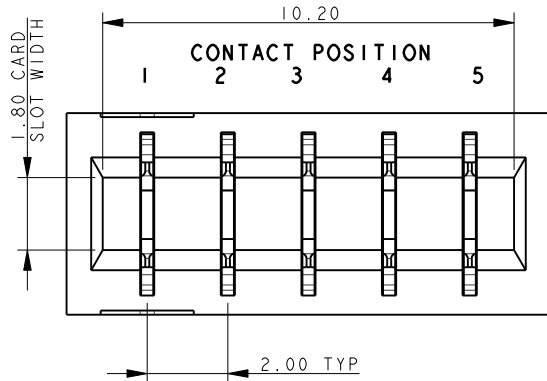

**NOTES:**

1. FOR MORE INFORMATION REFER TO PRODUCT SPEC 201-01-118.
2. DIMENSIONS ARE REFERENCE DIMENSIONS UNLESS TOLERANCED.
3. ARROW TO INDICATE CONTACT POSITION 1.
4. INSULATOR MATERIAL: NYLON 46, UL94 HB, COLOR SEE PAGE 70.
5. CONTACT MATERIAL: COPPER ALLOY, TIN PLATED ALL OVER.
6. PCB PAD, TIN PLATED.

## 5 WAY PCB BOARD LAYOUT

THICKNESS  $1.60 \pm 0.15$

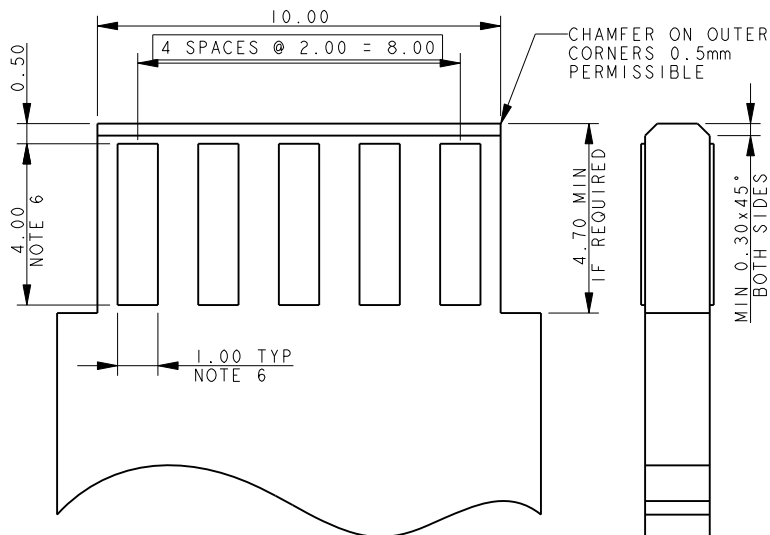

## PACKING DETAILS

REEL QTY	750
LEADER	500MM
TRAILER	500MM
REEL PER BOX	TBC

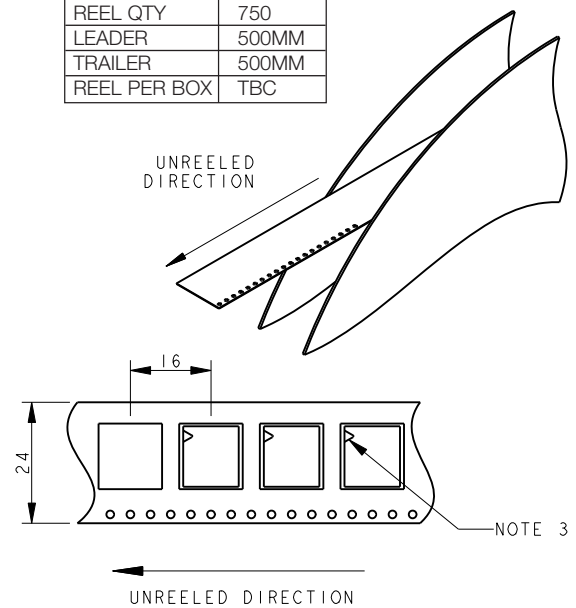

# One Piece Bottom Entry Card Edge



## Series 00-9159

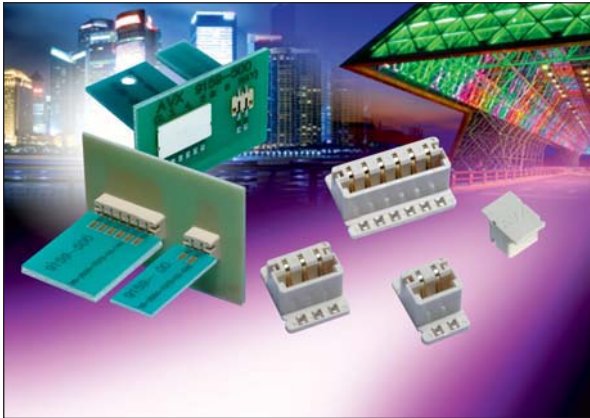

AVX has developed the 1-Piece bottom entry card edge connector to allow a perpendicular PCB to be mated to a top mounted main FR4 or metal core PCB from the bottom side. The most popular application on the market is in the LED bulb market where the FR4 driver card needs to mate to the top pads on a metal core LED board. A unique design feature of the AVX connector is that it allows for both a 1.6mm and 0.8mm mating PCB thickness, giving designers flexibility in their PCB layout and selection. The additional "Anti-Touch" cap can be ordered pre-assembled onto the connector or separately. This component protects an individual for electrical contact if the lens comes off or the bulb is broken. This is a UL mandated safety requirement.

The connectors offer a range of 2 positions to 6 positions in order to add additional functionality in the application design such as color control or specific control lines. The connector is UL rated with halogen free material and capable of operating temperatures up to 120°C.

### APPLICATIONS

- Provides perpendicular, bottom entry PCB mating to a top mounted card edge contact based connector
- Reference application notes 201-01-137
- Reference Product Specification 201-01-132UL

### FEATURES AND BENEFITS

- Available 2p-6p for added design functionality and color control in bulb applications
- Low profile top mounted design does not interfere with LED's
- Gold plated BeCu contact system for high reliability in harsh environments
- Accepts both 0.8mm and 1.6mm PCB's for added design options

### ELECTRICAL

- Current Rating: 2 Amps / Contact
- Voltage Rating: 250 VAC

### ENVIRONMENTAL

- Operating Temperature: -40°C to +120°C

### MECHANICAL

- Insulator Material: Halogen Free Nylon UL94VO
- Contact Material: Beryllium Copper
- Plating: Gold / Tin over Nickel
- Durability 10 Cycles

### HOW TO ORDER

**00**  
Prefix

**9159**  
Series

**00X**  
Number of Ways

Code	No of Ways	Details
002	2	Page 76
003	3	Page 77
004	4	Page 78
005	5	Page 79
006	6	Page 80

**501**  
Single Part PCB Strip Connector

501 = Through The Board, Edge Card, No Cap  
502 = Through The Board, Edge Card, Cap Fitted

**X**  
Insulator Color

Code	Color	Application
9	White	UL Approved Standard

**06**  
Plating Option

06 = Gold Plating on Nose with Tin on Tails

Certification: UL File #E90723



# One Piece Bottom Entry Card Edge



Series 00-9159

## 2 WAY THROUGH THE BOARD MATING EDGE CARD CONNECTOR

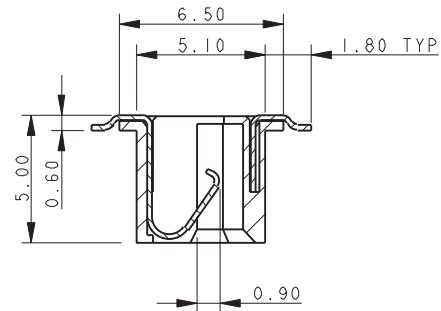
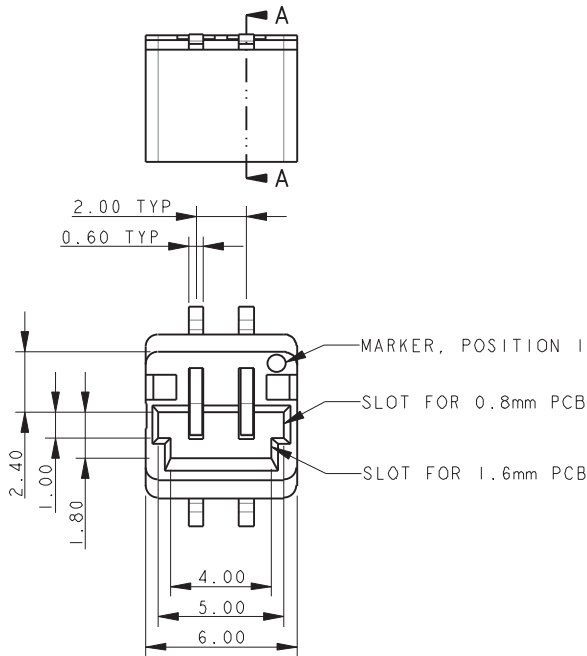

SECTION A-A

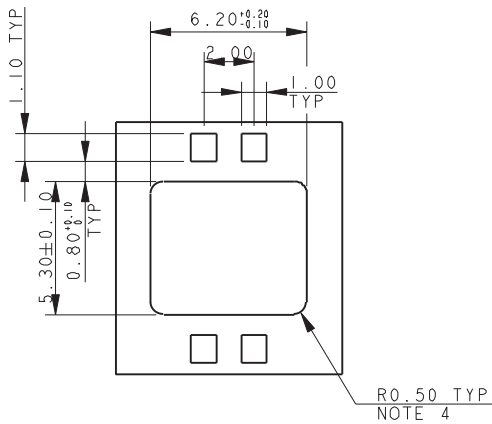
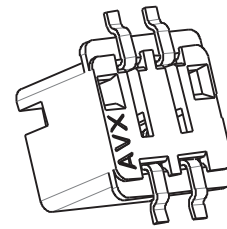

MOUNTING PCB  
(TOP SIDE)

## PACKING DETAILS

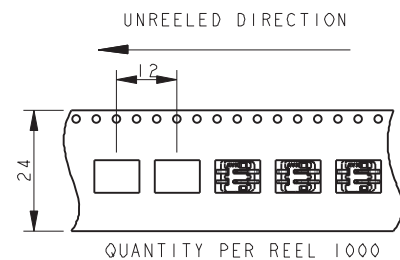
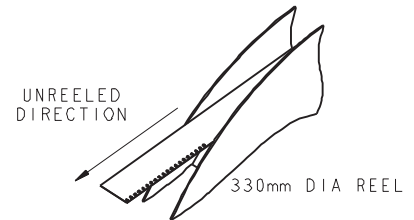

NOTES:

1. THROUGH THE BOARD 2 WAY EDGE CARD CONNECTOR. FOR FURTHER DETAILS REFER TO PRODUCT SPECIFICATION 201-01-136.
2. FOR MATING PCB EITHER 0.8MM OR 1.6MM THICK. REFER TO PAGE 81 FOR MATING PCB DETAILS.
3. CONNECTOR TOP MOUNTING ON PCB.
4. UP TO 0.5MM RAD TO MATCH CONNECTOR PROFILE.
5. ALL DIMENSIONS  $\pm 0.20$  UNLESS TOLERANCE SPECIFIED.
6. INSULATOR: PAR4T, GLASS FILLED, HALOGEN FREE, UL94 V-0, COLOR SEE PAGE 75.
7. CONTACT: COPPER ALLOW, NICKEL PLATED WITH GOLD FLASH ON NOSE AND TIN ON TAILS.
8. BRACKET: COPPER ALLOY, PLATING TIN OVER NICKEL.
9. PACKING IN TAPE AND REEL, 1000 PIECES PER REEL.
10. CONTACT TAILS COPLANARITY WITHIN 0.10.
11. REFER TO PAGE 84 FOR MATCHING PROTECTING CAP.
12. UL REFERENCE E90723.



# One Piece Bottom Entry Card Edge



Series 00-9159

## 3 WAY THROUGH THE BOARD MATING EDGE CARD CONNECTOR

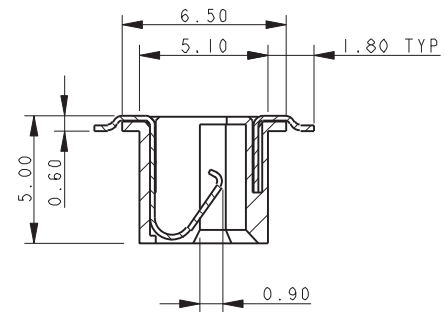
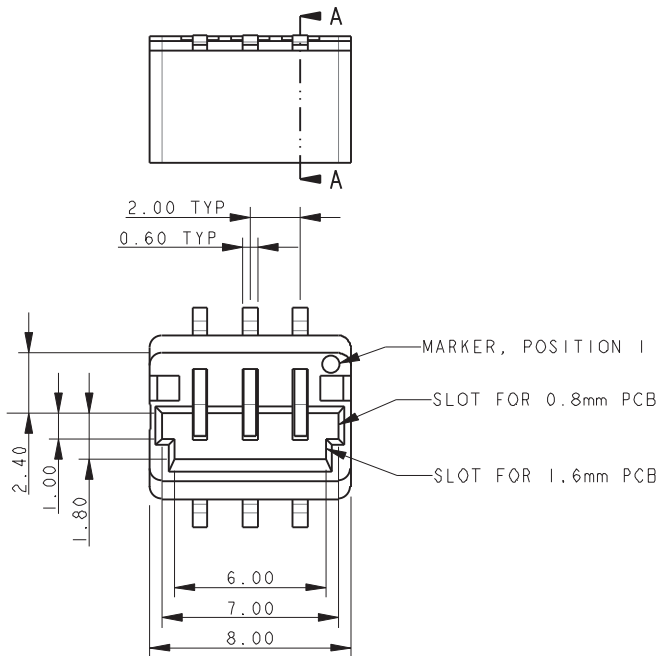

SECTION A-A

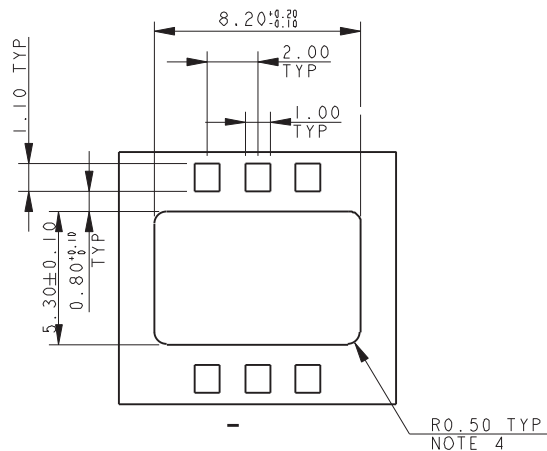
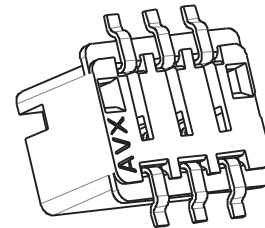

MOUNTING PCB  
(TOP SIDE)

## PACKING DETAILS

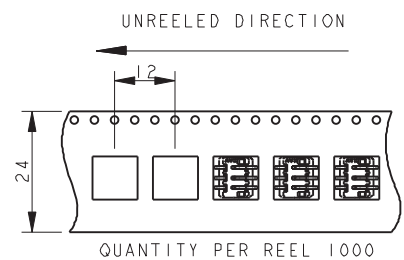
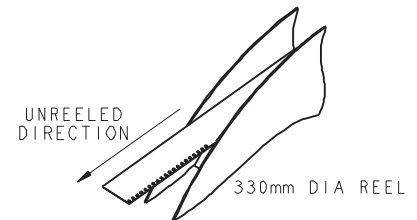

NOTES:

1. THROUGH THE BOARD 3 WAY EDGE CARD CONNECTOR. FOR FURTHER DETAILS REFER TO PRODUCT SPECIFICATION 201-01-136.
2. FOR MATING PCB EITHER 0.8MM OR 1.6MM THICK. REFER TO PAGE 81 FOR MATING PCB DETAILS.
3. CONNECTOR TOP MOUNTING ON PCB.
4. UP TO 0.5MM RAD TO MATCH CONNECTOR PROFILE.
5. ALL DIMENSIONS  $\pm 0.20$  UNLESS TOLERANCE SPECIFIED.
6. INSULATOR: PAR4T, GLASS FILLED, HALOGEN FREE, UL94 V-0, COLOR SEE PAGE 75.
7. CONTACT: COPPER ALLOW, NICKEL PLATED WITH GOLD FLASH ON NOSE AND TIN ON TAILS.
8. BRACKET: COPPER ALLOY, PLATING TIN OVER NICKEL.
9. PACKING IN TAPE AND REEL, 1000 PIECES PER REEL.
10. CONTACT TAILS COPLANARITY WITHIN 0.10.
11. REFER TO PAGE 84 FOR MATCHING PROTECTING CAP.
12. UL REFERENCE E90723.



# One Piece Bottom Entry Card Edge



Series 00-9159

## 4 WAY THROUGH THE BOARD MATING EDGE CARD CONNECTOR

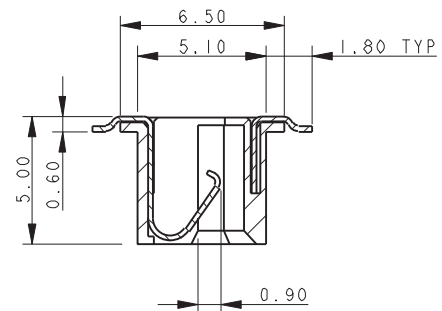
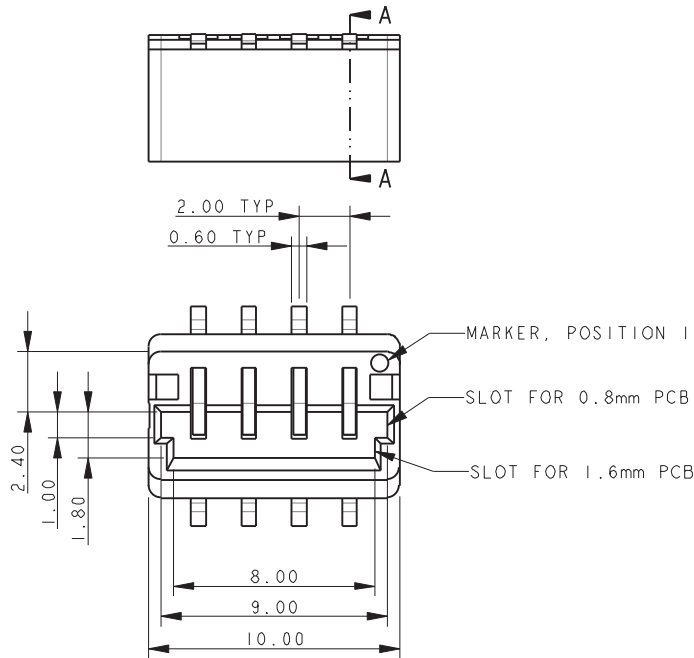

SECTION A-A

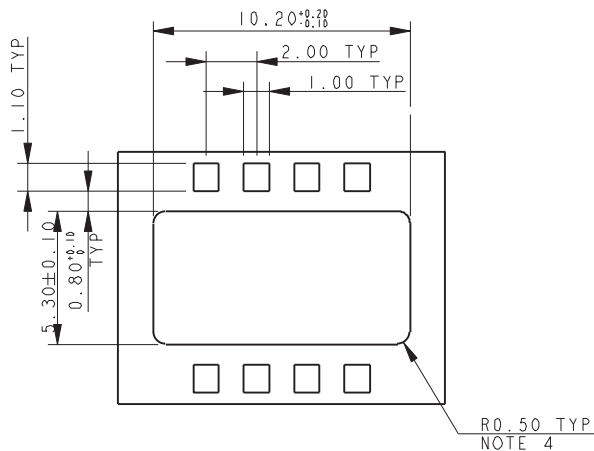
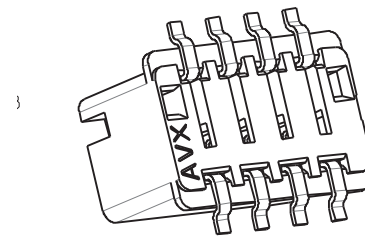

MOUNTING PCB  
(TOP SIDE)

### PACKING DETAILS

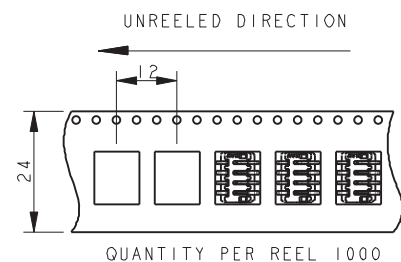
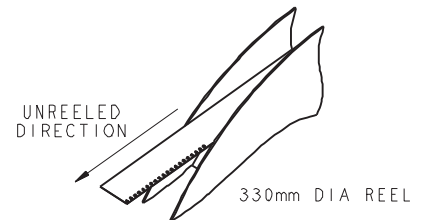

NOTES:

1. THROUGH THE BOARD 4 WAY EDGE CARD CONNECTOR. FOR FURTHER DETAILS REFER TO PRODUCT SPECIFICATION 201-01-136.
2. FOR MATING PCB EITHER 0.8MM OR 1.6MM THICK. REFER TO PAGE 81 FOR MATING PCB DETAILS.
3. CONNECTOR TOP MOUNTING ON PCB.
4. UP TO 0.5MM RAD TO MATCH CONNECTOR PROFILE.
5. ALL DIMENSIONS  $\pm 0.20$  UNLESS TOLERANCE SPECIFIED.
6. INSULATOR: PAR4T, GLASS FILLED, HALOGEN FREE, UL94 V-0, COLOR SEE PAGE 75.
7. CONTACT: COPPER ALLOW, NICKEL PLATED WITH GOLD FLASH ON NOSE AND TIN ON TAILS.
8. BRACKET: COPPER ALLOY, PLATING TIN OVER NICKEL.
9. PACKING IN TAPE AND REEL, 1000 PIECES PER REEL.
10. CONTACT TAILS COPLANARITY WITHIN 0.10.
11. REFER TO PAGE 84 FOR MATCHING PROTECTING CAP.
12. UL REFERENCE E90723.





# One Piece Bottom Entry Card Edge



Series 00-9159

## 5 WAY THROUGH THE BOARD MATING EDGE CARD CONNECTOR

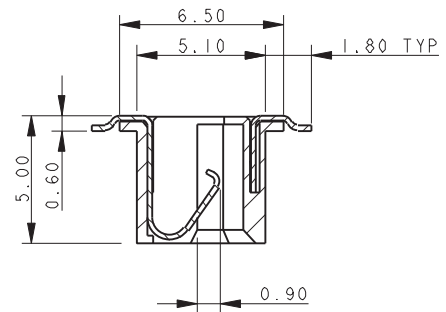
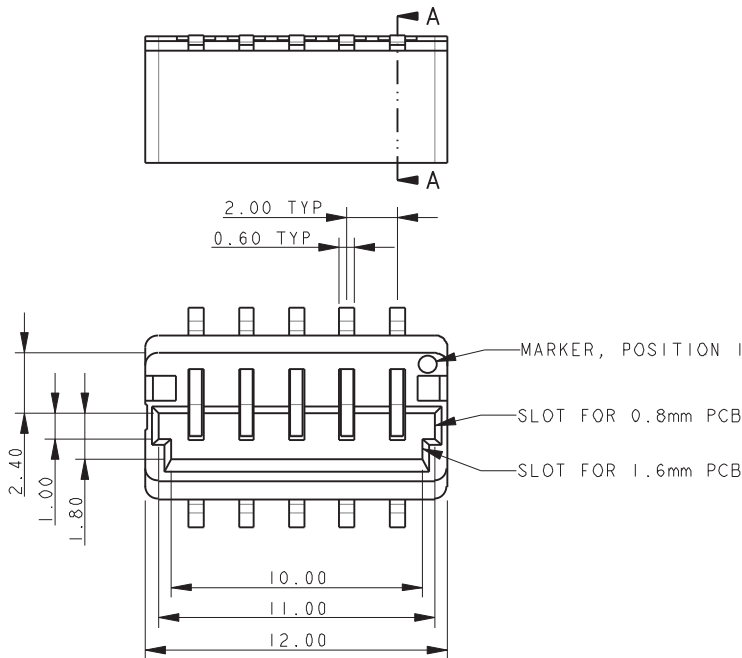

SECTION A-A

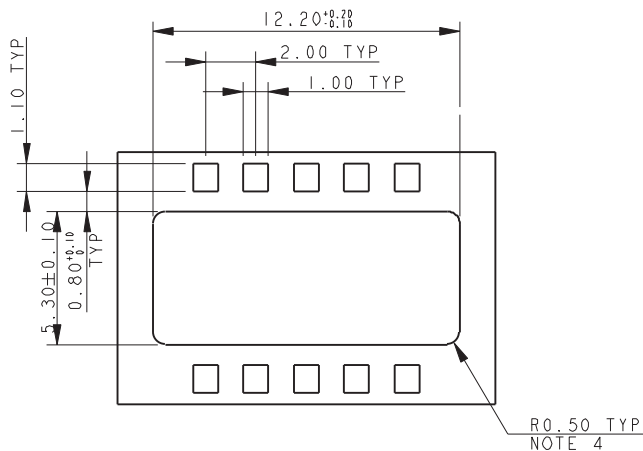
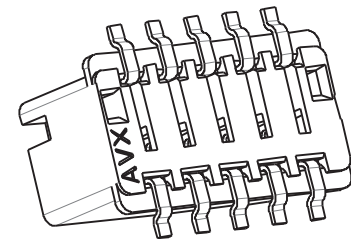

MOUNTING PCB  
(TOP SIDE)

## PACKING DETAILS

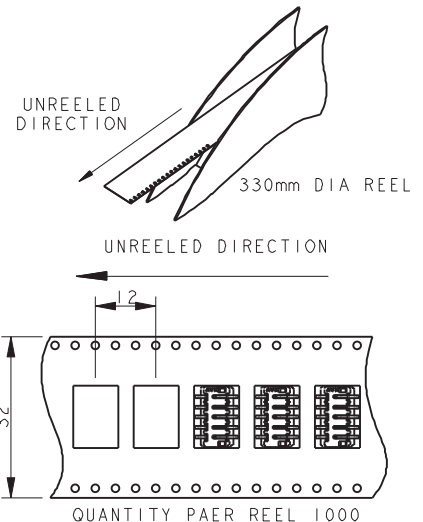

NOTES:

1. THROUGH THE BOARD 5 WAY EDGE CARD CONNECTOR. FOR FURTHER DETAILS REFER TO PRODUCT SPECIFICATION 201-01-136.
2. FOR MATING PCB EITHER 0.8MM OR 1.6MM THICK. REFER TO PAGE 81 FOR MATING PCB DETAILS.
3. CONNECTOR TOP MOUNTING ON PCB.
4. UP TO 0.5MM RAD TO MATCH CONNECTOR PROFILE.
5. ALL DIMENSIONS  $\pm 0.20$  UNLESS TOLERANCE SPECIFIED.
6. INSULATOR: PAR4T, GLASS FILLED, HALOGEN FREE, UL94 V-0, COLOR SEE PAGE 75.
7. CONTACT: COPPER ALLOW, NICKEL PLATED WITH GOLD FLASH ON NOSE AND TIN ON TAILS.
8. BRACKET: COPPER ALLOY, PLATING TIN OVER NICKEL.
9. PACKING IN TAPE AND REEL, 1000 PIECES PER REEL.
10. CONTACT TAILS COPLINARITY WITHIN 0.10.
11. REFER TO PAGE 81 FOR MATCHING PROTECTING CAP.
12. UL REFERENCE E90723.



# One Piece Bottom Entry Card Edge



Series 00-9159

## 6 WAY THROUGH THE BOARD MATING EDGE CARD CONNECTOR

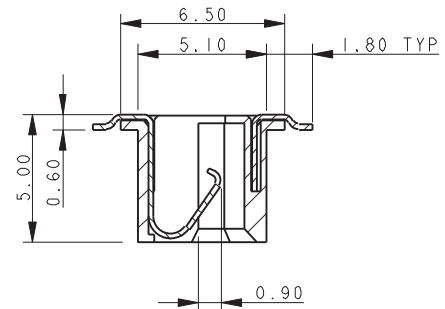
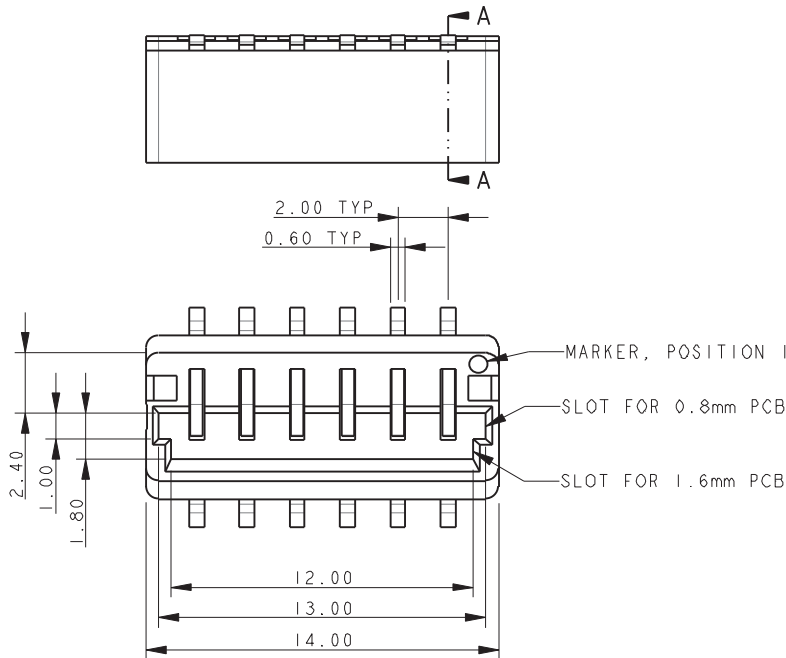

SECTION A-A

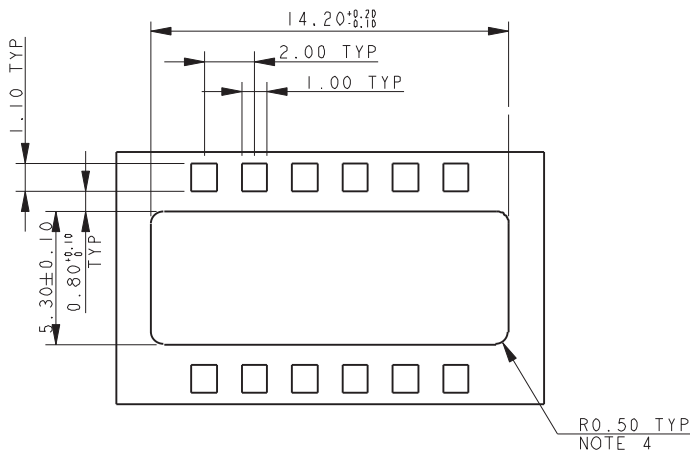
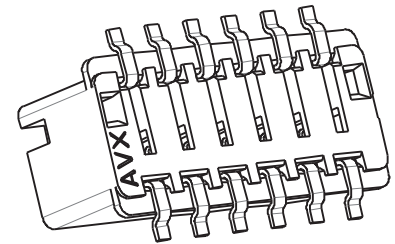

MOUNTING PCB  
(TOP SIDE)

## PACKING DETAILS

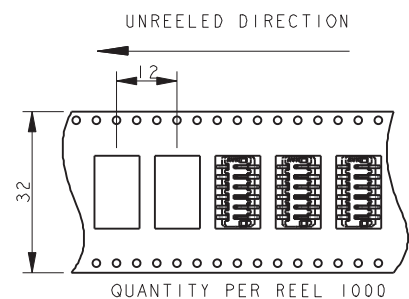
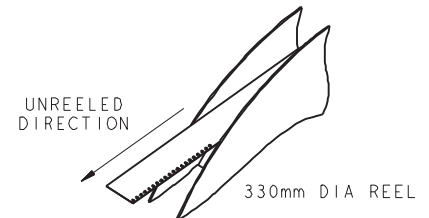

### NOTES:

1. THROUGH THE BOARD 6 WAY EDGE CARD CONNECTOR. FOR FURTHER DETAILS REFER TO PRODUCT SPECIFICATION 201-01-136.
2. FOR MATING PCB EITHER 0.8MM OR 1.6MM THICK. REFER TO PAGE 81 FOR MATING PCB DETAILS.
3. CONNECTOR TOP MOUNTING ON PCB.
4. UP TO 0.5MM RAD TO MATCH CONNECTOR PROFILE.
5. ALL DIMENSIONS ±0.20 UNLESS TOLERANCE SPECIFIED.
6. INSULATOR: PAR4T, GLASS FILLED, HALOGEN FREE, UL94 V-0, COLOR SEE PAGE 75.
7. CONTACT: COPPER ALLOW, NICKEL PLATED WITH GOLD FLASH ON NOSE AND TIN ON TAILS.
8. BRACKET: COPPER ALLOY, PLATING TIN OVER NICKEL.
9. PACKING IN TAPE AND REEL, 1000 PIECES PER REEL.
10. CONTACT TAILS COPLANARITY WITHIN 0.10.
11. REFER TO PAGE 84 FOR MATCHING PROTECTING CAP.
12. UL REFERENCE E90723.

# One Piece Bottom Entry Card Edge



Series 00-9159

THROUGH THE BOARD MATING EDGE CARD CONNECTOR – WITH CAP

00-9159-00X-502-X06

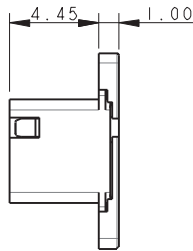
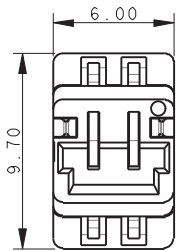

00-9159-002-502-906

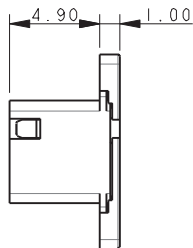
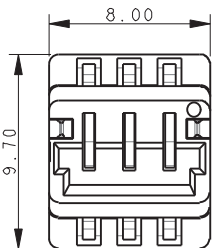

00-9159-003-502-906

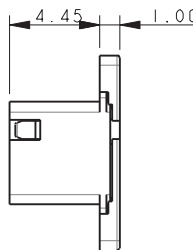
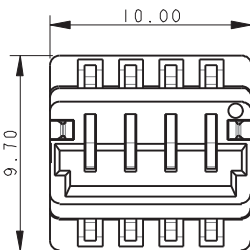

00-9159-004-502-906

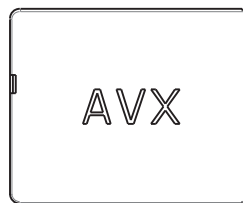
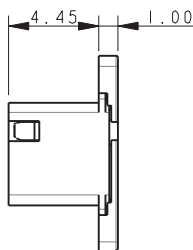
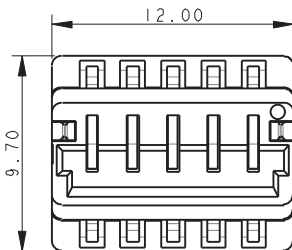

00-9159-005-502-906

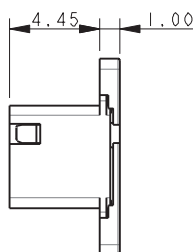
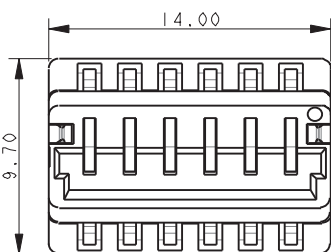

00-9159-006-502-906

NOTES:

1. 00-9159-00X-501-X06 WITH CAP SUPPLIED FITTED.
2. DRAWINGS SHOW OUTLINE DIMENSIONS OF THE 00-9159-00X-502-X06 ASSEMBLIES. ALL OTHER DETAILS ARE AS 00-9159-00X-501-X06 ON PAGES 76-80.
3. GENERAL TOLERANCE  $\pm 0.20$ .
4. PACKING ORIENTATION.
5. UL REFERENCE E90723.

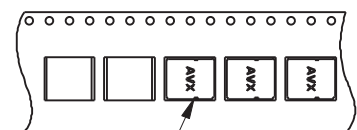

NOTE 4



# One Piece Bottom Entry Card Edge



Series 00-9159

## THROUGH THE BOARD MATING EDGE CARD CONNECTOR – MATING PCB

### MATING PCB – 0.8MM PCB

### MATING PCB – 1.6MM PCB

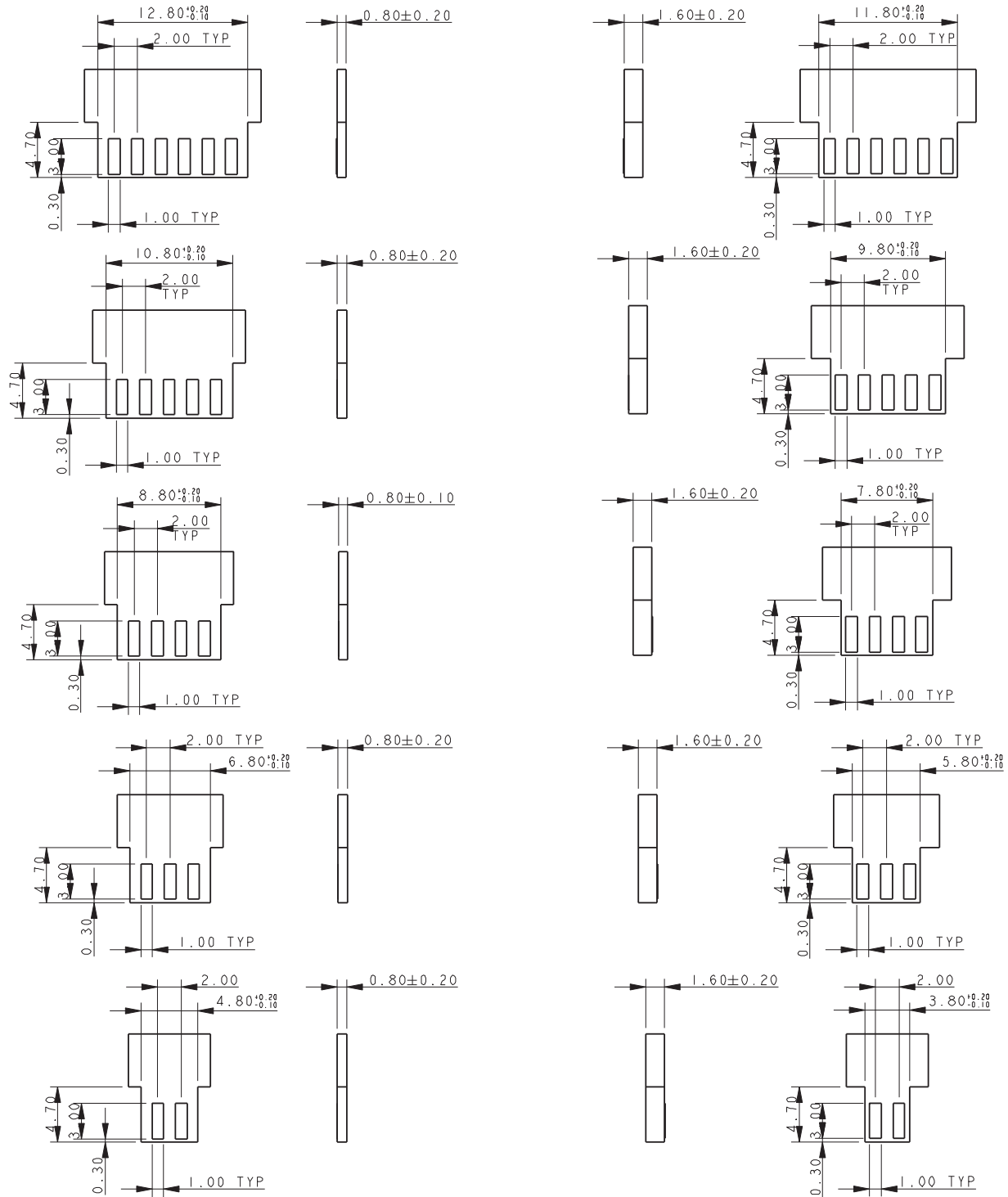

NOTES:

1. CORRECT DIMENSIONS FOR EITHER 0.80MM OR 1.60MM PCB THICKNESS MUST BE USED.
2. THICKNESS OF PCB INCLUDES ALL LAYERS INCLUDING COPPER AND PLATING.
3. PADS TO BE PLATED GOLD OVER NICKEL UNDERCOAT.
4. GENERAL TOLERANCE  $\pm 0.10$  UNLESS STATED.



# One Piece Bottom Entry Card Edge



Series 00-9159

## THROUGH THE BOARD MATING EDGE CARD CONNECTOR

### CONNECTOR/PCB ASSEMBLY 0.8MM MATING PCB NO CAP

### CONNECTOR/PCB ASSEMBLY 1.6MM MATING PCB WITH CAP

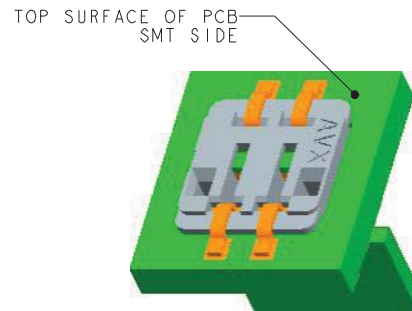
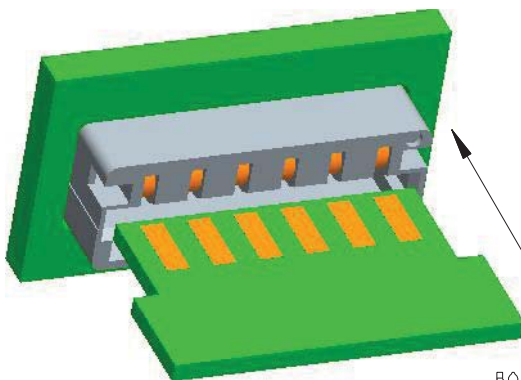
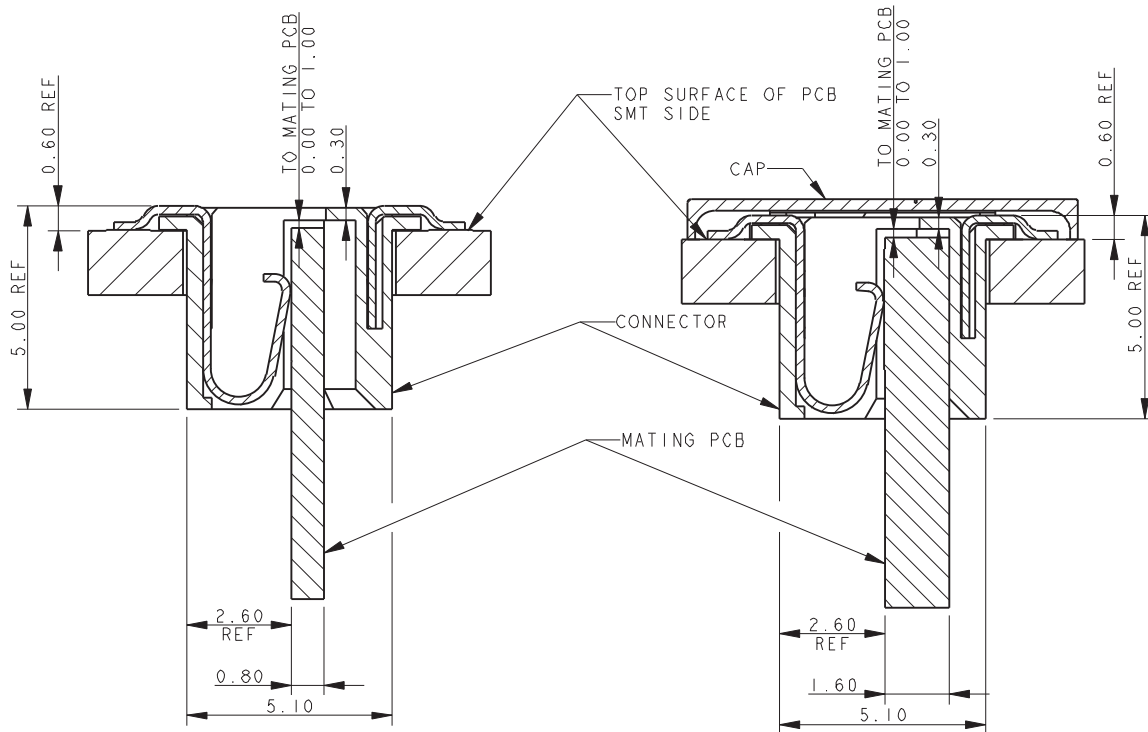

#### NOTES:

1. THROUGH THE BOARD EDGE CARD CONNECTOR.
2. FOR MATING PCB EITHER 0.8MM OR 1.6MM THICK. REFER TO PAGE 81 FOR MATING PCB DETAILS.
3. CONNECTOR TOP MOUNTING ON PCB.
4. PAD DETAILS ON THE MATING PCB ALLOW CONTACT TO BE MADE IN ANY POSITION FROM THE STOP FACE UP TO 1MM FROM THE STOP FACE.
5. GENERAL TOLERANCE  $\pm 0.20$  UNLESS STATED.



# One Piece Bottom Entry Card Edge

Series 00-9159

## ACCESSORY – PROTECTING CAP

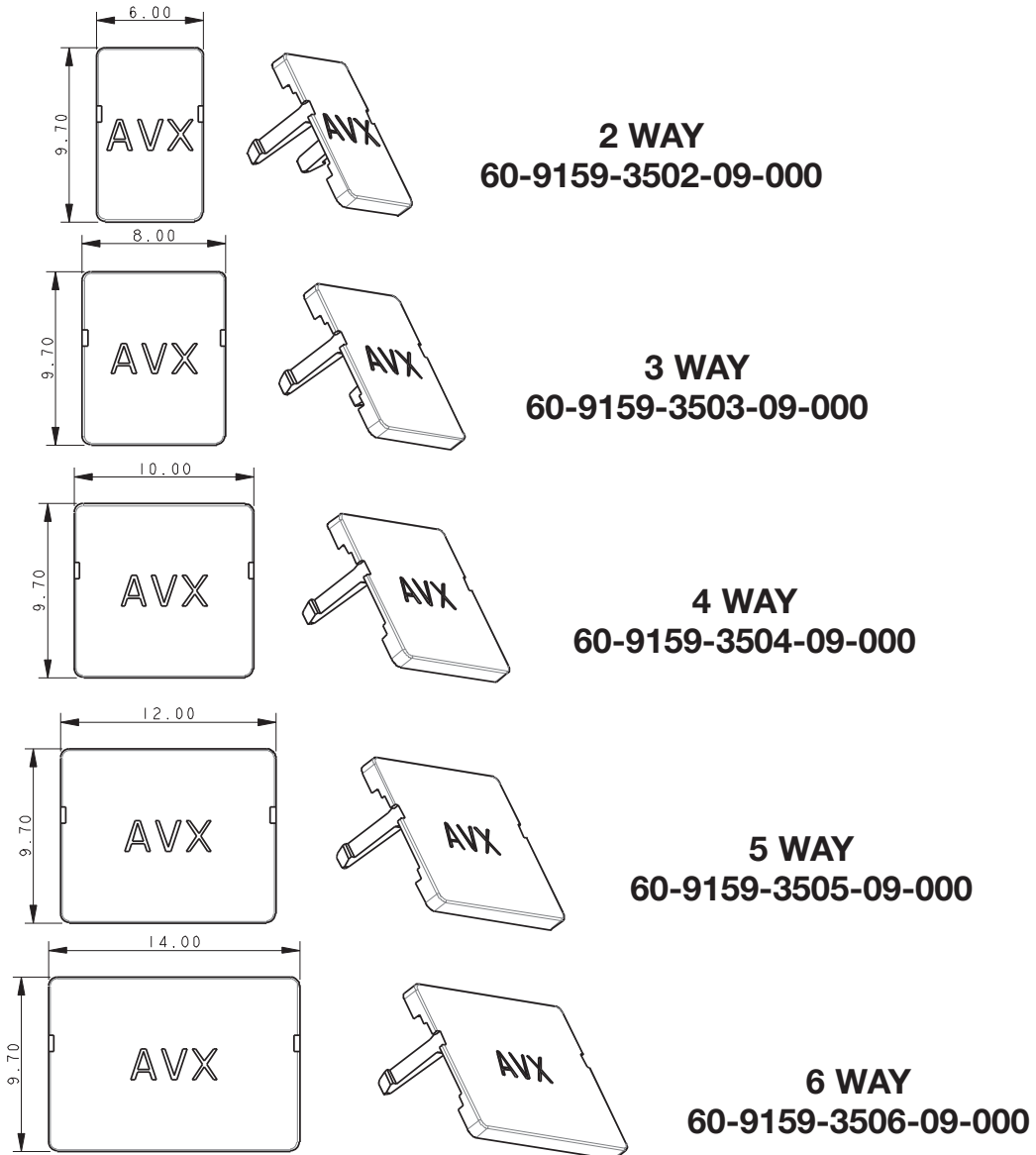

**NOTES:**

1. PROTECTING CAP, ACCESSORY, NOT SUPPLIED WITH CONNECTOR.
2. CLIPS TO TOP OF CONNECTOR TO COVE ALL METAL COMPONENTS.
3. MATERIAL: PA4T, GLASS FILLED, HALOGEN FREE, UL94 V-0. COLOR CODE REFER TO PAGE 70, "X" IN PART NUMBER.
4. SUPPLIED IN BAGS OF 100 PIECES.
5. GENERAL TOLERANCE  $\pm 0.20$ .
6. UL REFERENCE E90723.

## ASSEMBLED CAP

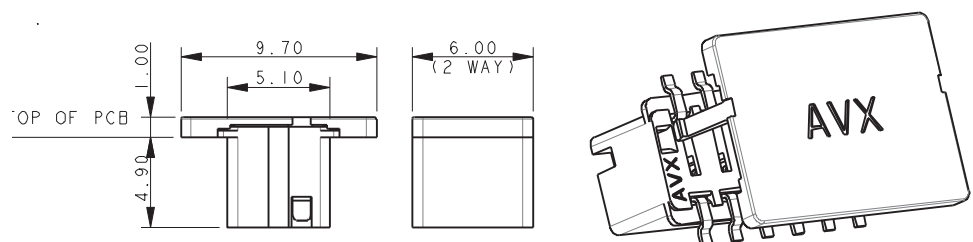

# One Piece Top Entry Card Edge



## Series 00-9159

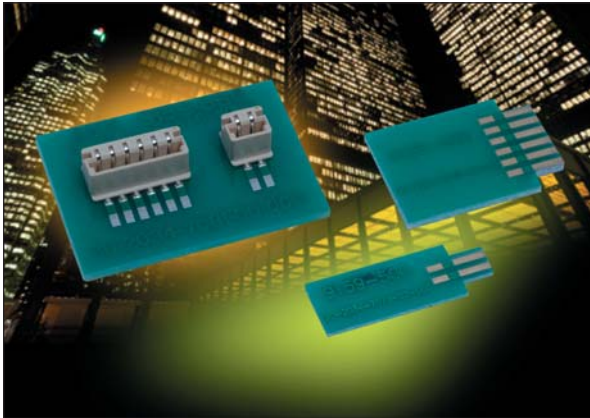

AVX continues to develop unique connectors to fill the gap in the industrial market, specifically as it relates to low pin count requirements. The newest addition to AVX's broadening line of one piece card edge connectors is the 2p-6p top entry version which complements the bottom entry version released last year. This new configuration will allow small perpendicular daughter cards to be plugged in from the top side of the main board. The single connector option offers an alternative to the more traditional and costly two piece solution.

This small connector is packed with several key features that provide significant functionality in a broad range of robust industrial applications. The contact system is gold plated for enhanced reliability, signal integrity and full 2A/contact current rating. The PCB board opening is dual slotted to accept either a 0.8mm or 1.6mm thick daughter card within the same connector body.

### APPLICATIONS

- Provides a one piece connector solution for low pin count perpendicular PCB mating in industrial applications
- Facilitates easy plug ability for small module/programming cards

### FEATURES AND BENEFITS

- 2 Amp per contact current rating meets robust industrial application requirements
- Removable pick and place cap supports robotic placement and SMT termination
- Gold plated BeCu contact system for high reliability in harsh environments
- Accepts both 0.8mm and 1.6mm PCB's for added design options

### ELECTRICAL

- Current Rating: 2 Amps / Contact
- Voltage Rating: 250 VAC

### ENVIRONMENTAL

- Operating Temperature: -40°C to +120°C

### MECHANICAL

- Insulator Material: Nylon UL94VO
- Contact Material: Beryllium Copper
- Plating: Gold / Tin over Nickel
- Durability 10 Cycles

### HOW TO ORDER

**00**  
Prefix

**9159**  
Series

**00X**  
Number of Ways

Code	No of Ways	Details
002	2	Page 86
003	3	Page 87
004	4	Page 88
005	5	Page 89
006	6	Page 90

**551**  
Single Part PCB Strip Connector  
551 = Top Mounting on Board Edge Card

**X**  
Insulator Color

Code	Color	Application
9	White	UL Approved Standard

**06**  
Plating Option  
06 = Gold Plating on Nose with Tin on Tails

Certification: UL File #E90723



# One Piece Top Entry Card Edge



Series 00-9159

## 2 WAY TOP MOUNTING EDGE CARD CONNECTOR

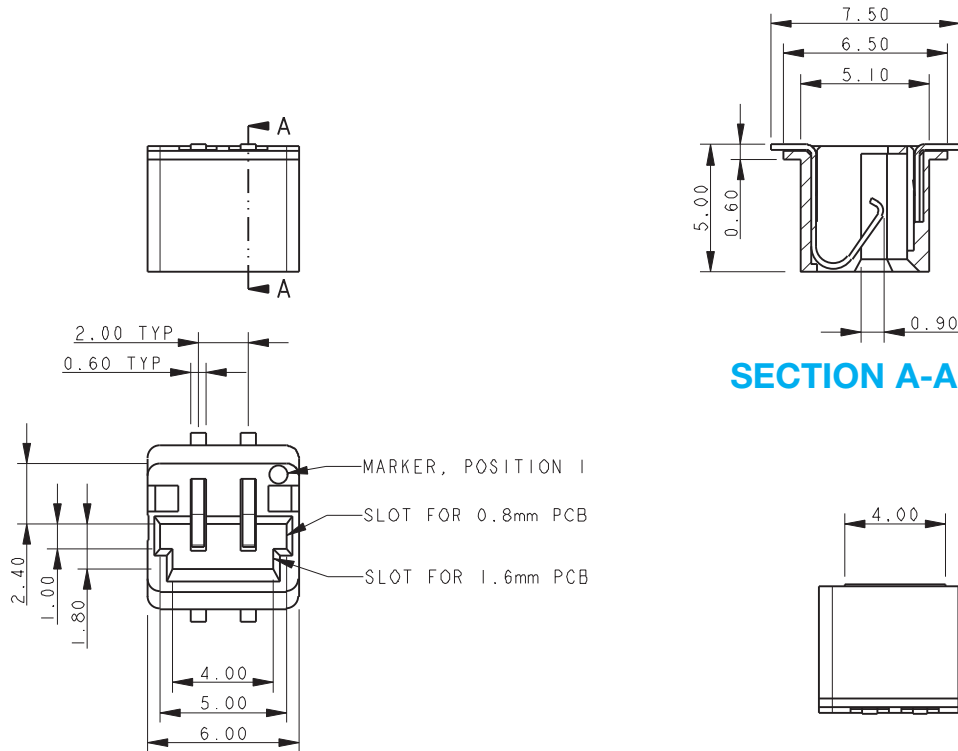

### SUGGESTED PCB LAYOUT

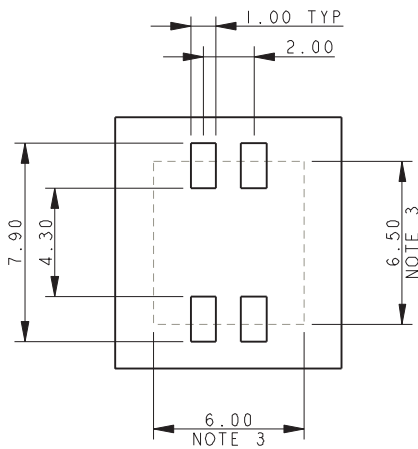

PICK AND PLACE TAPE  
REMOVE AFTER SOLDERING

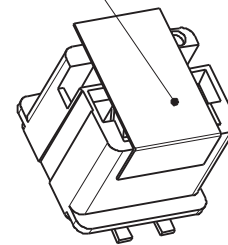

### PACKING DETAILS

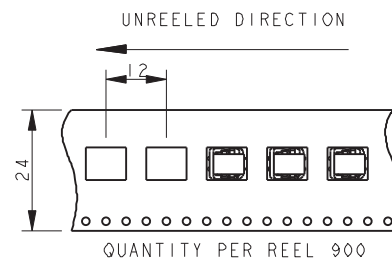
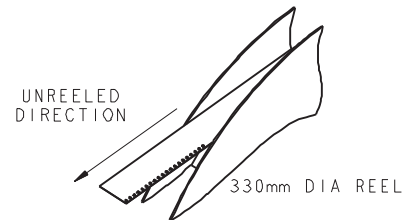

#### NOTES:

1. 5159-500 SERIES TOP MOUNTING EDGE CARD CONNECTOR, 2 WAY. FOR FURTHER DETAILS REFER TO PRODUCT SPECIFICATION 201-01-136 AND APPLICATION NOTES 201-01-137.
2. FOR MATING PCB EITHER 0.8MM OR 1.6MM THICK PCB. (DETAILS SAME AS 9159-500), REFER TO PAGE 91.
3. CONNECTOR OUTLINE.
4. ALL DIMENSIONS  $\pm 0.20$  UNLESS TOLERANCE SPECIFIED.
5. INSULATOR: PA4T, GLASS FILLED, HALOGEN FREE, UL94 V-0, COLOR REFER TO PAGE 85.
6. CONTACT: COPPER ALLOY, NICKEL PLATED WITH GOLD FLASH ON NOSE AND TIN ON TAILS.
7. BRACKET: COPPER ALLOY, PLATING, TIN OVER NICKEL.
8. PACKING IN TAPE AND REEL, 900 PIECES PER REEL.
9. CONTACT TAILS COPLANARITY WITHIN 0.10.
10. UL PRODUCT REFERENCE E90723 (US AND CANADA).





# One Piece Top Entry Card Edge



Series 00-9159

## 3 WAY TOP MOUNTING EDGE CARD CONNECTOR

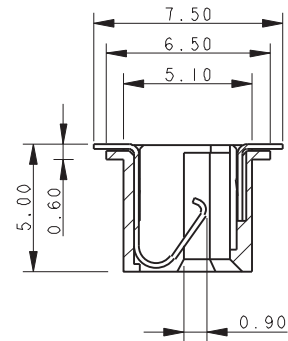
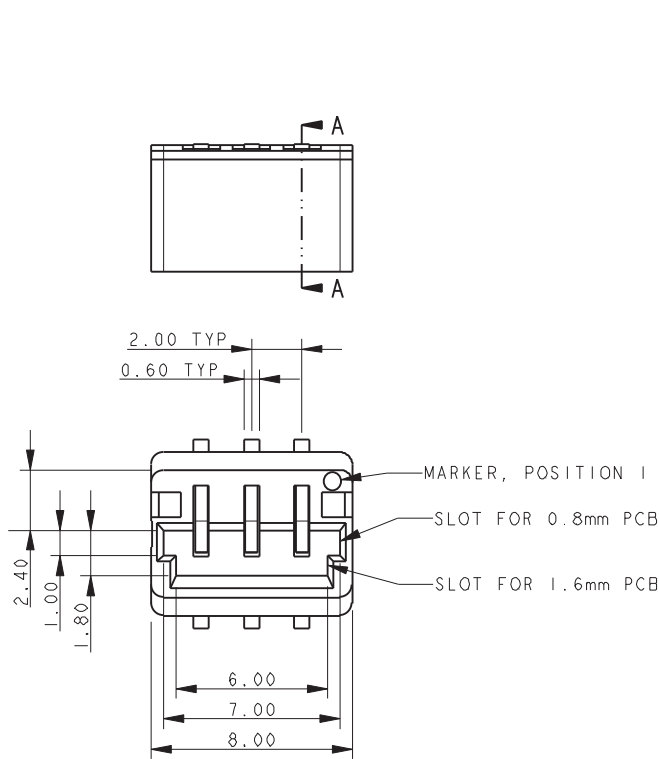

SECTION A-A

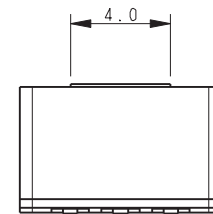

### SUGGESTED PCB LAYOUT

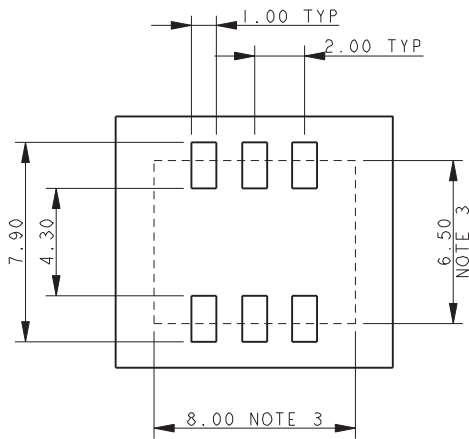

PICK AND PLACE TAPE  
REMOVE AFTER SOLDERING

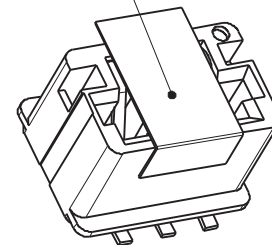

PACKING DETAILS

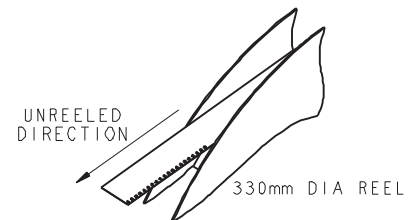

UNREELED DIRECTION

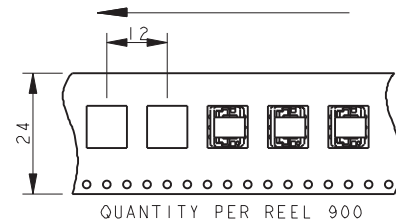

1. 5159-500 SERIES TOP MOUNTING EDGE CARD CONNECTOR, 3 WAY. FOR FURTHER DETAILS REFER TO PRODUCT SPECIFICATION 201-01-136 AND APPLICATION NOTES 201-01-137.
2. FOR MATING PCB EITHER 0.8MM OR 1.6MM THICK PCB. (DETAILS SAME AS 9159-500), REFER TO PAGE 91.
3. CONNECTOR OUTLINE.
4. ALL DIMENSIONS  $\pm 0.20$  UNLESS TOLERANCE SPECIFIED.
5. INSULATOR: PA4T, GLASS FILLED, HALOGEN FREE, UL94 V-0, COLOR REFER TO PAGE 85.
6. CONTACT: COPPER ALLOY, NICKEL PLATED WITH GOLD FLASH ON NOSE AND TIN ON TAILS.
7. BRACKET: COPPER ALLOY, PLATING, TIN OVER NICKEL.
8. PACKING IN TAPE AND REEL, 900 PIECES PER REEL.
9. CONTACT TAILS COPLANARITY WITHIN 0.10.
10. UL PRODUCT REFERENCE E90723 (US AND CANADA).



# One Piece Top Entry Card Edge



Series 00-9159

## 4 WAY TOP MOUNTING EDGE CARD CONNECTOR

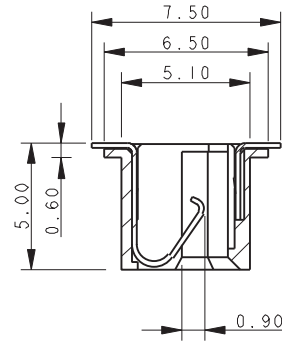
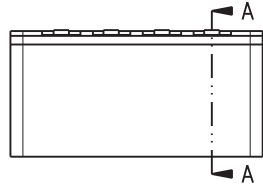

**SECTION A-A**

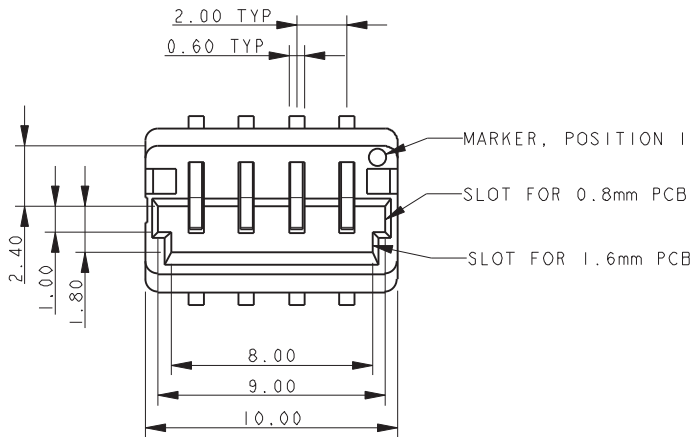

**SUGGESTED PCB LAYOUT**

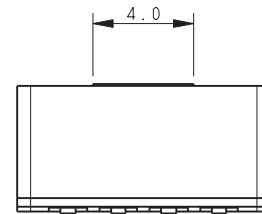

PICK AND PLACE TAPE  
REMOVE AFTER SOLDERING

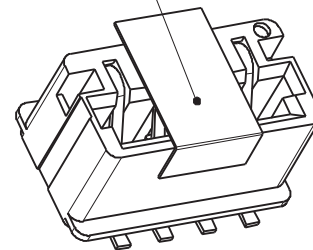

**PACKING DETAILS**

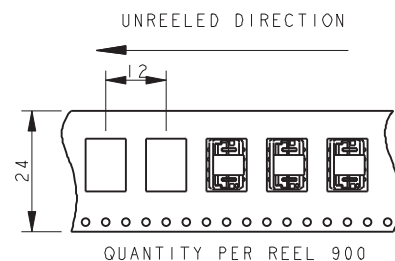
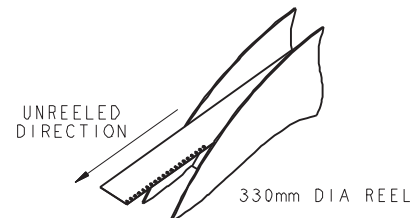
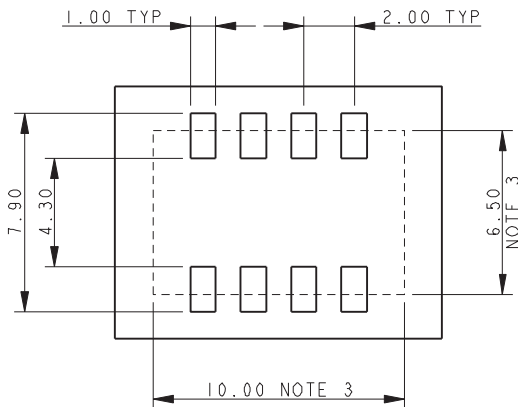

1. 5159-500 SERIES TOP MOUNTING EDGE CARD CONNECTOR, 4 WAY. FOR FURTHER DETAILS REFER TO PRODUCT SPECIFICATION 201-01-136 AND APPLICATION NOTES 201-01-137.
2. FOR MATING PCB EITHER 0.8MM OR 1.6MM THICK PCB. (DETAILS SAME AS 9159-500), REFER TO PAGE 91.
3. CONNECTOR OUTLINE.
4. ALL DIMENSIONS  $\pm 0.20$  UNLESS TOLERANCE SPECIFIED.
5. INSULATOR: PA4T, GLASS FILLED, HALOGEN FREE, UL94 V-0, COLOR REFER TO PAGE 85.
6. CONTACT: COPPER ALLOY, NICKEL PLATED WITH GOLD FLASH ON NOSE AND TIN ON TAILS.
7. BRACKET: COPPER ALLOY, PLATING, TIN OVER NICKEL.
8. PACKING IN TAPE AND REEL, 900 PIECES PER REEL.
9. CONTACT TAILS COPLANARITY WITHIN 0.10.
10. UL PRODUCT REFERENCE E90723 (US AND CANADA).



# One Piece Top Entry Card Edge



Series 00-9159

## 5 WAY TOP MOUNTING EDGE CARD CONNECTOR

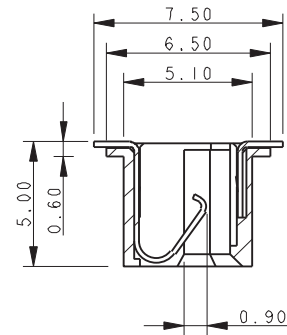
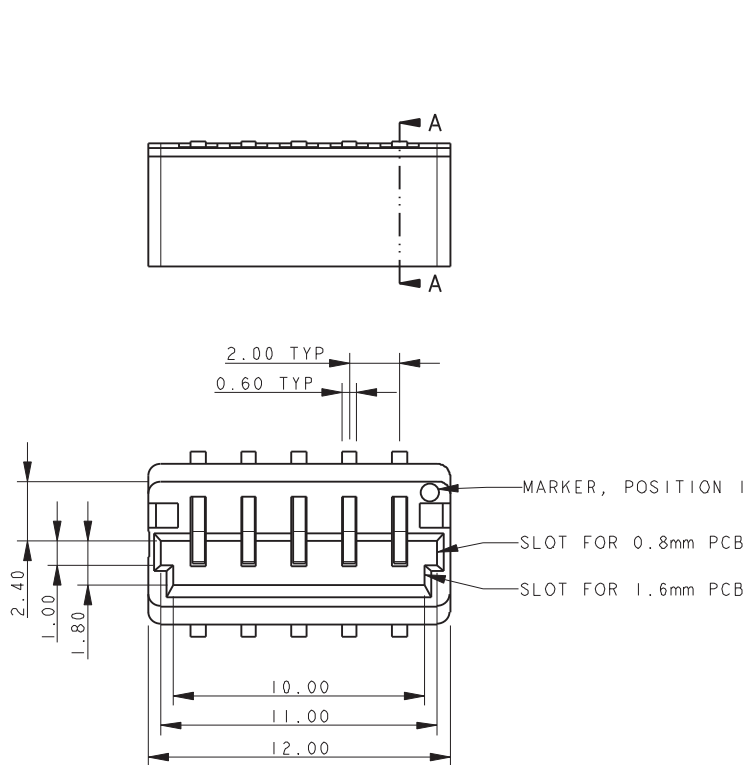

SECTION A-A

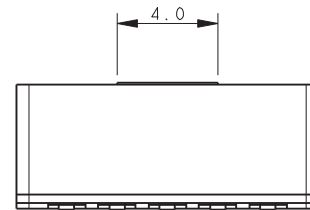

### SUGGESTED PCB LAYOUT

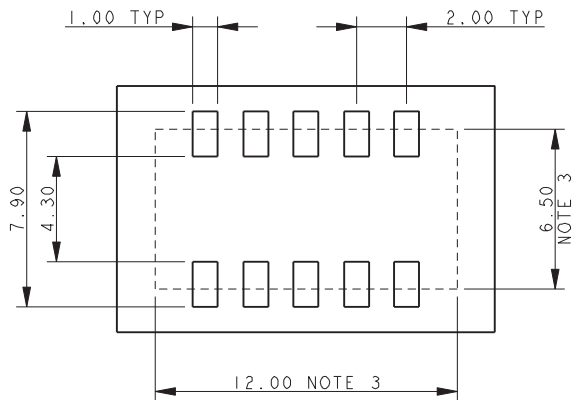

PICK AND PLACE TAPE  
REMOVE AFTER SOLDERING

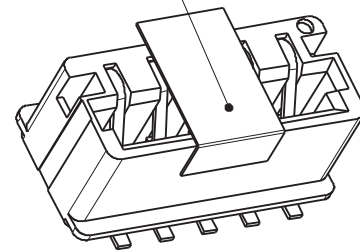

### PACKING DETAILS

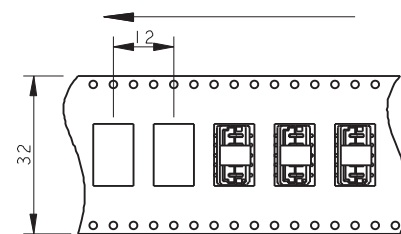
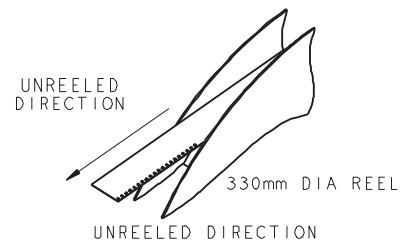

QUANTITY PER REEL 900

- 5159-500 SERIES TOP MOUNTING EDGE CARD CONNECTOR, 5 WAY. FOR FURTHER DETAILS REFER TO PRODUCT SPECIFICATION 201-01-136 AND APPLICATION NOTES 201-01-137.
- FOR MATING PCB EITHER 0.8MM OR 1.6MM THICK PCB. (DETAILS SAME AS 9159-500), REFER TO PAGE 91.
- CONNECTOR OUTLINE.
- ALL DIMENSIONS  $\pm 0.20$  UNLESS TOLERANCE SPECIFIED.
- INSULATOR: PA4T, GLASS FILLED, HALOGEN FREE, UL94 V-0, COLOR REFER TO PAGE 85.
- CONTACT: COPPER ALLOY, NICKEL PLATED WITH GOLD FLASH ON NOSE AND TIN ON TAILS.
- BRACKET: COPPER ALLOY, PLATING, TIN OVER NICKEL.
- PACKING IN TAPE AND REEL, 900 PIECES PER REEL.
- CONTACT TAILS COPLANARITY WITHIN 0.10.
- UL PRODUCT REFERENCE E90723 (US AND CANADA).



# One Piece Top Entry Card Edge



Series 00-9159

## 6 WAY TOP MOUNTING EDGE CARD CONNECTOR

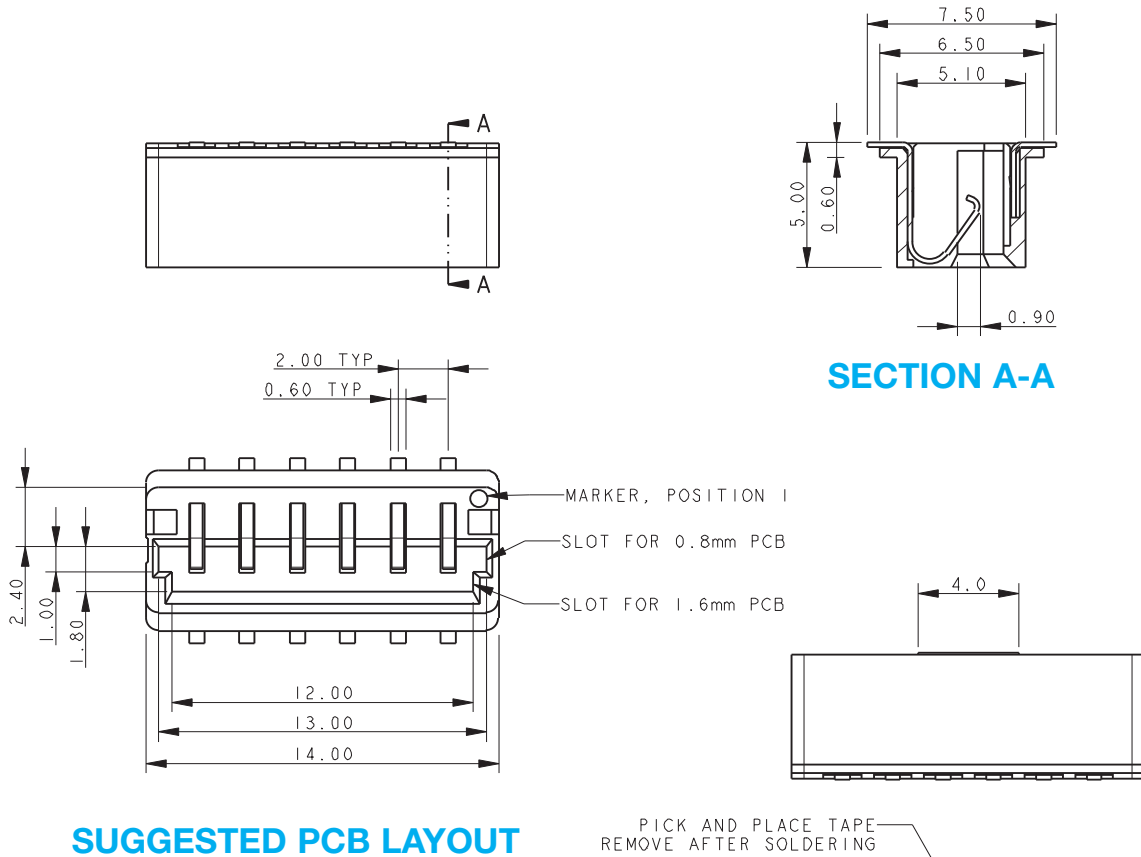

### SUGGESTED PCB LAYOUT

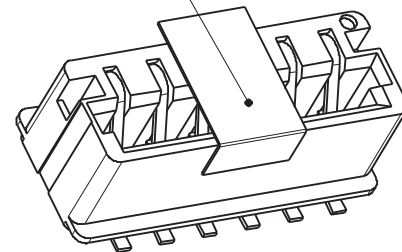
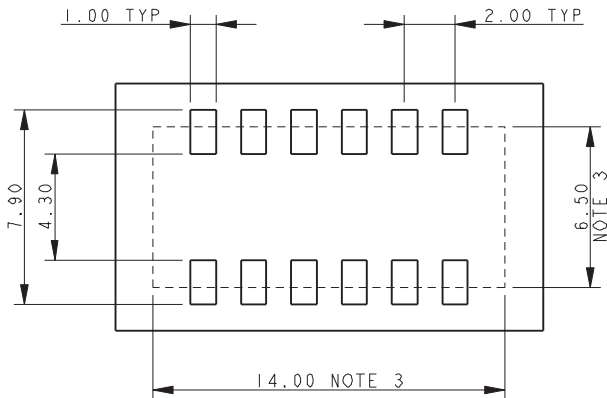

### PACKING DETAILS

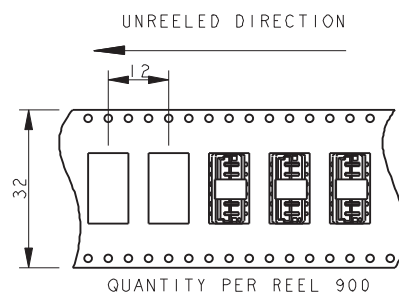
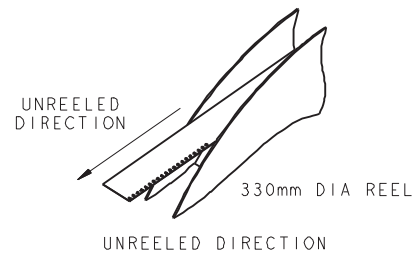

1. 5159-500 SERIES TOP MOUNTING EDGE CARD CONNECTOR, 6 WAY. FOR FURTHER DETAILS REFER TO PRODUCT SPECIFICATION 201-01-136 AND APPLICATION NOTES 201-01-137.
2. FOR MATING PCB EITHER 0.8MM OR 1.6MM THICK PCB. (DETAILS SAME AS 9159-500), REFER TO PAGE 91.
3. CONNECTOR OUTLINE.
4. ALL DIMENSIONS  $\pm 0.20$  UNLESS TOLERANCE SPECIFIED.
5. INSULATOR: PA4T, GLASS FILLED, HALOGEN FREE, UL94 V-0, COLOR REFER TO PAGE 85.
6. CONTACT: COPPER ALLOY, NICKEL PLATED WITH GOLD FLASH ON NOSE AND TIN ON TAILS.
7. BRACKET: COPPER ALLOY, PLATING, TIN OVER NICKEL.
8. PACKING IN TAPE AND REEL, 900 PIECES PER REEL.
9. CONTACT TAILS COPLINARITY WITHIN 0.10.
10. UL PRODUCT REFERENCE E90723 (US AND CANADA).



# One Piece Top Entry Card Edge



Series 00-9159

## TOP MOUNTING EDGE CARD CONNECTOR – MATING PCB

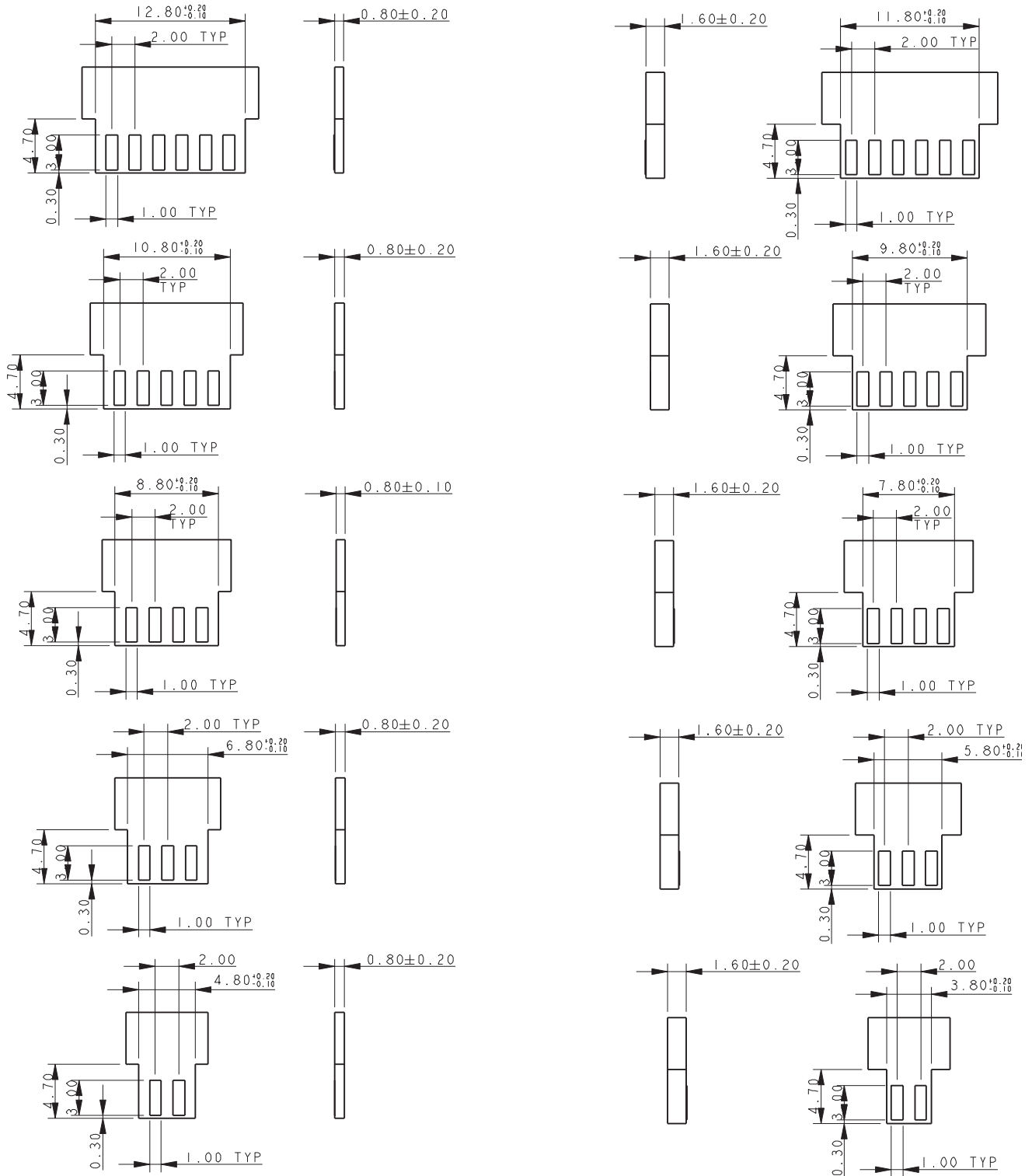

NOTES:

1. CORRECT DIMENSION FOR EITHER 0.80MM OR 1.60MM PCB THICKNESS MUST BE USED.
2. THICKNESS OF PCB INCLUDES ALL LAYERS INCLUDING COPPER AND PLATING.
3. PADS TO BE PLATED GOLD OVER NICKEL UNDERCOAT.
4. GENERAL TOLERANCE  $\pm 0.10$  UNLESS STATED.

# One Piece Top Entry Card Edge



Series 00-9159

## TOP MOUNTING EDGE CARD CONNECTOR ASSEMBLY

### CONNECTOR/PCB ASSEMBLY 0.8mm MATING PCB

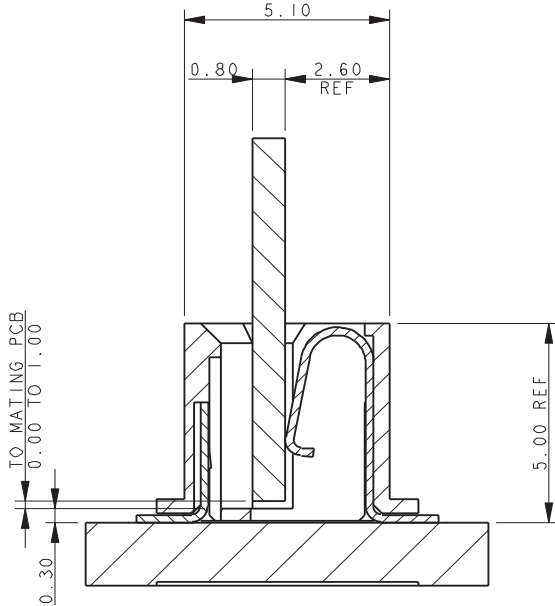

### CONNECTOR/PCB ASSEMBLY 1.6mm MATING PCB

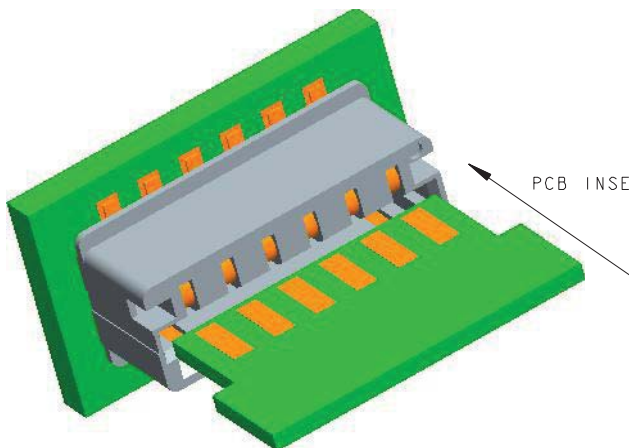
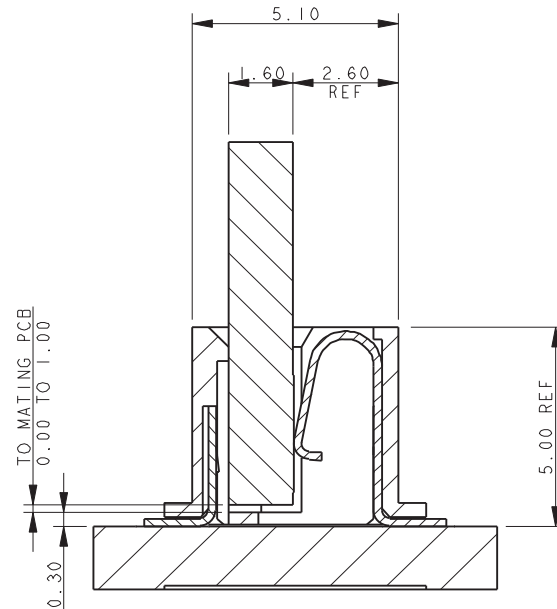

SUPPLIED WITH  
PICK AND PLACE TAPE

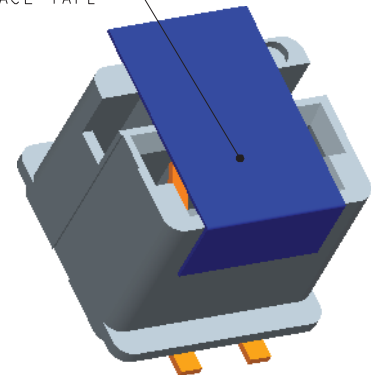

#### NOTES:

1. 9159-500 SERIES TOP MOUNTING EDGE CARD CONNECTOR.
2. FOR MATING PCB EITHER 0.8MM OR 1.6MM THICK. REFER TO PAGE 6 FOR MATING PCB DETAILS.
3. CONNECTOR SURFACE MOUNTING ON PCB.
4. PAD DETAILS ON THE MATING PCB ALLOW CONTACT TO BE MADE IN ANY POSITION FORM THE STOP FACE UP TO 1MM FROM THE STOP FACE.
5. GENERAL TOLERANCE  $\pm 0.20$  UNLESS STATED.

# Open Ended Card Edge



## Series 00-9159



AVX was challenged with increasing the pin count density as well as minimizing the size of the existing coplanar BTB card edge connector for linear strip lighting. The current product is a 2.0mm with single contacts that straddle the PCB to make electrical connection on both the top and bottom side of the board. By simply changing the contacts to a double sided configuration (separate contacts for both the top and bottom of the PCB), AVX was able to double the pin count in the same 2.0mm pitch with minimal to no impact on the electrical performance of the connector. Reducing the size of the connector required a complete new design as the target was a 4p connector with a total length of 4.0mm. To achieve this, AVX removed the end walls and then added a center support/keying rib to pre-align the PCB during mating. This rib then holds the PCB in the proper functional location.

The new family of connectors is available with contact sizes of 4, 6, 8 and 10 positions, doubling the current products range. The current rating will be 3A for the 4p and 6p, and then drop to 2.5A for the 8p and 10p connector. The connector supports the standard 1.6mm PCB thickness.

This new connector provides the highest density to reliably connect two in-line PCB's together in the most cost effective assembled solution. More importantly, the increased pin count allows for more flexibility in mixing and matching power and signal lines.

### APPLICATIONS

- Linear LED strip lighting
- Commercial/Industrial co-planar or extended card applications
- Reference Product Specification 201-01-144

### FEATURES AND BENEFITS

- Miniaturized size, achieves 1.0mm in length for each number of contacts (4p = 4.0mm)
- Double Ended/Double Sided contacts for increased pin count density on standard 1.6mm thick PCB's
- Central polarizing/location rib assures proper mating and PCB location
- High current capabilities: 3A; 4p/6p and 2.5A; 8p/10p
- Economical high force Tin-to-Tin contact interface

### ELECTRICAL

- Current Rating: 3.0 amps 4p/6p and 2.5 amps 8p/10p
- Voltage Rating: 300 VAC

### ENVIRONMENTAL

- Operating Temperature: -40°C to +125°C

### MECHANICAL

- Insulator Material: Nylon 46: UL94VO
- Contact Material: Phosphor Bronze
- Plating: Tin over Nickel
- Durability: 5 Cycles

### HOW TO ORDER

<b>00</b>	<b>9159</b>	<b>XXX</b>	<b>0</b>	<b>61</b>	<b>X</b>	<b>1</b>	<b>6</b>																								
Prefix	Series	Number of Ways	Single Part PCB Strip Connector	PCB Thickness 61 = Open Ended PCB Thickness 1.6-±0.10	Insulator Color	Packaging Options 1 = bag	Plating Option 06 = Pure Tin all over																								
		<table border="1"> <thead> <tr> <th>Code</th> <th>No of Ways</th> <th>Details</th> </tr> </thead> <tbody> <tr> <td>004</td> <td>4</td> <td>Page 94</td> </tr> <tr> <td>006</td> <td>6</td> <td>Page 95</td> </tr> <tr> <td>008</td> <td>8</td> <td>Page 96</td> </tr> <tr> <td>010</td> <td>10</td> <td>Page 97</td> </tr> </tbody> </table>	Code	No of Ways	Details	004	4	Page 94	006	6	Page 95	008	8	Page 96	010	10	Page 97			<table border="1"> <thead> <tr> <th>Code</th> <th>Color</th> <th>Application</th> </tr> </thead> <tbody> <tr> <td>8</td> <td>Black</td> <td>Special Order</td> </tr> <tr> <td>9</td> <td>White</td> <td>Standard</td> </tr> </tbody> </table>	Code	Color	Application	8	Black	Special Order	9	White	Standard		
Code	No of Ways	Details																													
004	4	Page 94																													
006	6	Page 95																													
008	8	Page 96																													
010	10	Page 97																													
Code	Color	Application																													
8	Black	Special Order																													
9	White	Standard																													

Certification: UL File #E90723



# Open Ended Card Edge



Series 00-9159

## 4 WAY SINGLE PART PCB STRIP CONNECTOR – OPEN ENDED

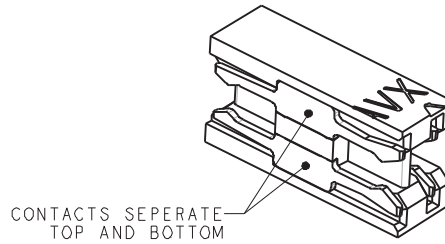
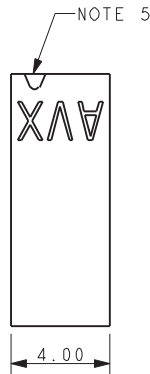

### SECTION VIEW THROUGH CONTACT

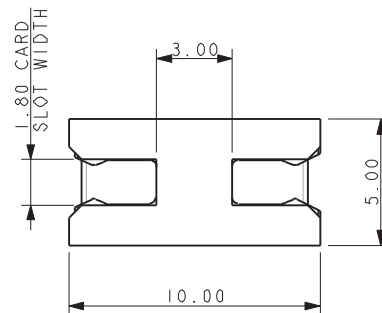
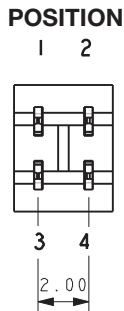

#### NOTES:

1. INSULATOR MATERIAL NYLON 46, UL94 V-0.  
COLOR REFER TO PAGE 93.
2. CONTACT MATERIAL COPPER ALLOY, TIN PLATED
3. PARTS TO BE SUPPLIED IN BAGS, 1000 PIECES PER BAG.
4. GENERAL TOLERANCE  $\pm 0.20\text{MM}$  UNLESS STATED.
5. ARROW ADJACENT TO CONTACT POSITION 1.
6. PCB PAD, TIN PLATED.
7. FURTHER DETAILS REFER TO ELCO SPECIFICATION 201-01-144.

### SUGGESTED PCB LAYOUT

PADS THE SAME UPPER AND LOWER FACES  
PCB THICKNESS  $1.60 \pm 0.10\text{MM}$  (OVER PADS)

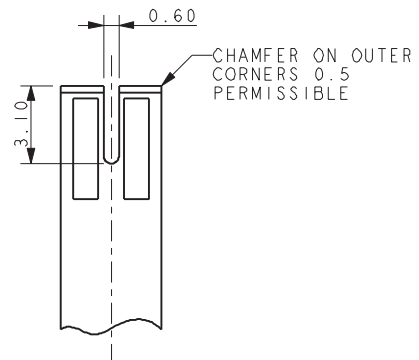
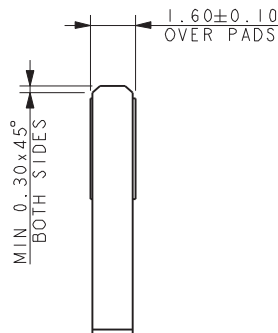
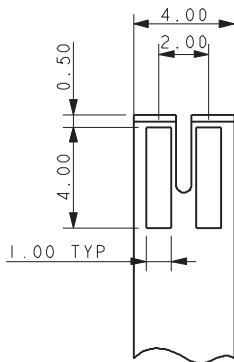



# Open Ended Card Edge



Series 00-9159

## 6 WAY SINGLE PART PCB STRIP CONNECTOR – OPEN ENDED

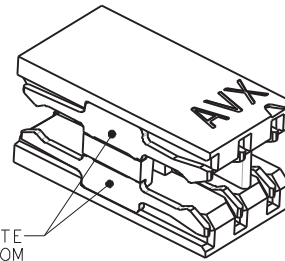
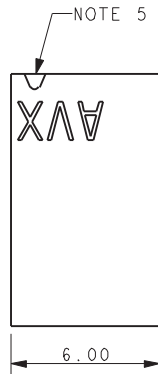

CONTACTS SEPERATE  
TOP AND BOTTOM

### SECTION VIEW THROUGH CONTACT

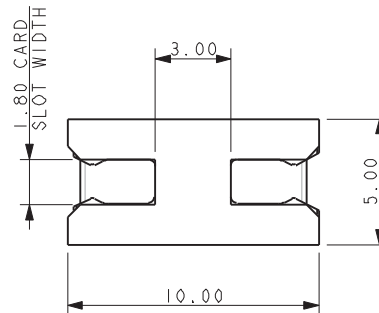
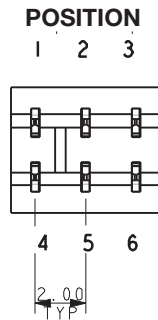

NOTES:

1. INSULATOR MATERIAL NYLON 46, UL94 V-0.  
COLOR REFER TO PAGE 93.
2. CONTACT MATERIAL COPPER ALLOY, TIN PLATED
3. PARTS TO BE SUPPLIED IN BAGS, 1000 PIECES PER BAG.
4. GENERAL TOLERANCE  $\pm 0.20\text{MM}$  UNLESS STATED.
5. ARROW ADJACENT TO CONTACT POSITION 1.
6. PCB PAD, TIN PLATED.
7. FURTHER DETAILS REFER TO ELCO SPECIFICATION 201-01-144.

### SUGGESTED PCB LAYOUT

PADS THE SAME UPPER AND LOWER FACES  
PCB THICKNESS  $1.60 \pm 0.10\text{MM}$  (OVER PADS)

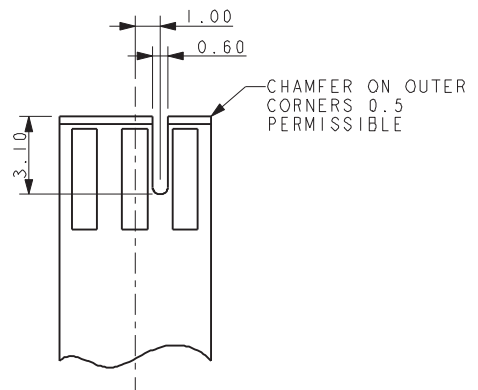
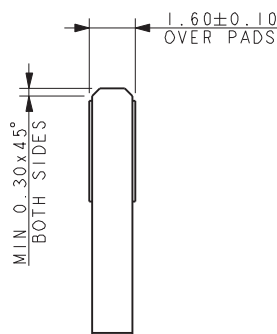
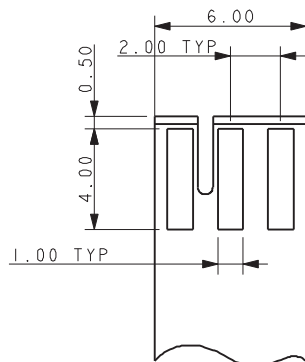

# Open Ended Card Edge



Series 00-9159

## 8 WAY SINGLE PART PCB STRIP CONNECTOR – OPEN ENDED

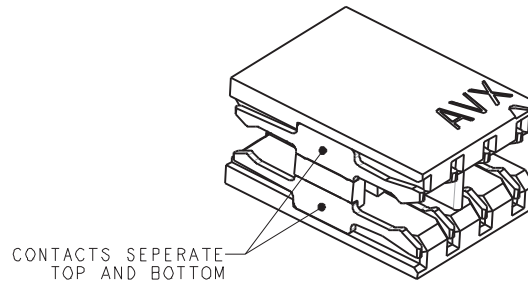

### SECTION VIEW THROUGH CONTACT

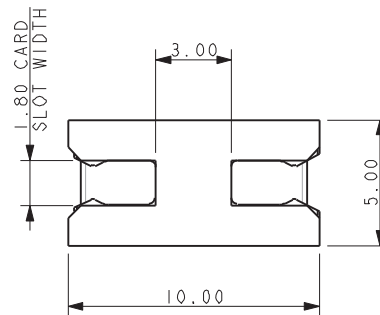
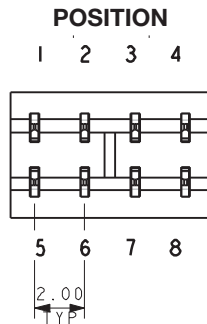

NOTES:

- INSULATOR MATERIAL NYLON 46, UL94 V-0.  
COLOR REFER TO PAGE 93.
- CONTACT MATERIAL COPPER ALLOY, TIN PLATED
- PARTS TO BE SUPPLIED IN BAGS, 1000 PIECES PER BAG.
- GENERAL TOLERANCE  $\pm 0.20$ MM UNLESS STATED.
- ARROW ADJACENT TO CONTACT POSITION 1.
- PCB PAD, TIN PLATED.
- FURTHER DETAILS REFER TO ELCO SPECIFICATION 201-01-144.

### SUGGESTED PCB LAYOUT

PADS THE SAME UPPER AND LOWER FACES

PCB THICKNESS  $1.60 \pm 0.10$ MM (OVER PADS)

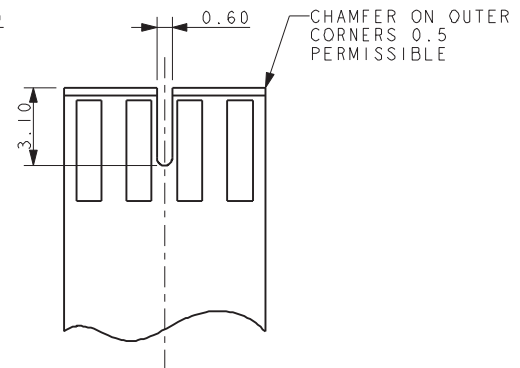
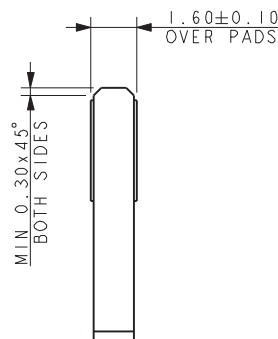
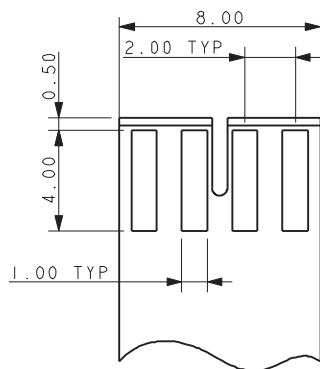

# Open Ended Card Edge



Series 00-9159

## 10 WAY SINGLE PART PCB STRIP CONNECTOR – OPEN ENDED

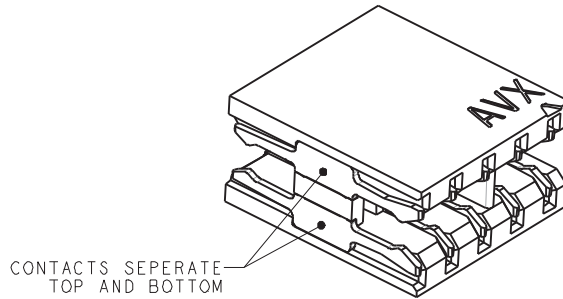
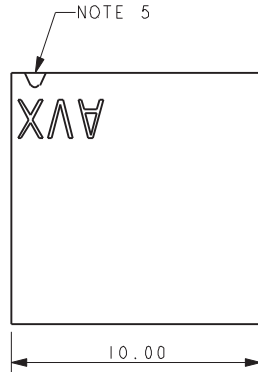

### SECTION VIEW THROUGH CONTACT

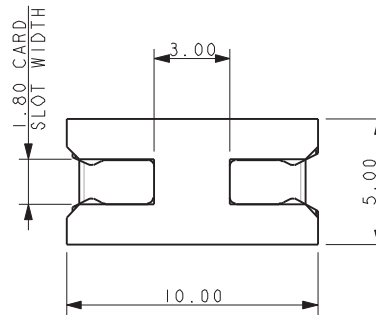
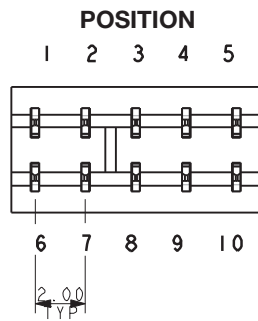

NOTES:

1. INSULATOR MATERIAL NYLON 46, UL94 V-0. COLOR REFER TO PAGE 93.
2. CONTACT MATERIAL COPPER ALLOY, TIN PLATED
3. PARTS TO BE SUPPLIED IN BAGS, 1000 PIECES PER BAG.
4. GENERAL TOLERANCE  $\pm 0.20\text{MM}$  UNLESS STATED.
5. ARROW ADJACENT TO CONTACT POSITION 1.
6. PCB PAD, TIN PLATED.
7. FURTHER DETAILS REFER TO ELCO SPECIFICATION 201-01-144.

### SUGGESTED PCB LAYOUT

PADS THE SAME UPPER AND LOWER FACES  
PCB THICKNESS  $1.60 \pm 0.10\text{MM}$  (OVER PADS)

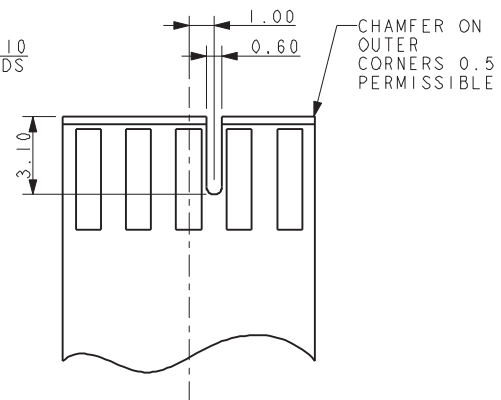
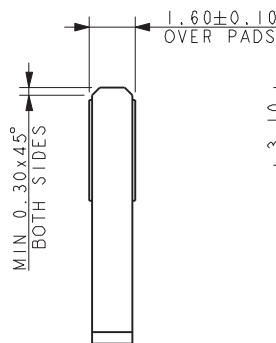
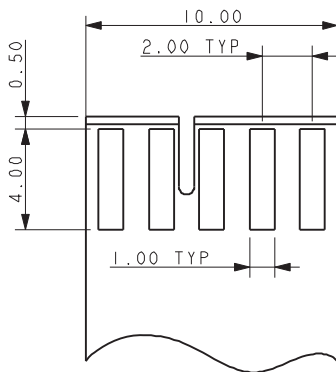

# BTB Compression



## Series 9155-100



AVX has been leading the industry with reliable Board-to-Board (BTB) compression connectors for commercial, medical and harsh industrial applications, obtaining the very first contact patent in the early 1990's. The broad range of connectors offers both signal contacts which support 1 Amp/contact up to 40 position as well as low pin count (LPC) power contacts up to 3 Amps/contact.

The newest addition is the Ultra Low Profile (ULP) power connector that supports a 1.3mm compressed height, the lowest on the market. Gold plated Beryllium Copper (BeCu) contacts offers the most reliable and resilient contact performance in this miniature package. The sweeping contact design offers 0.7mm deflection range, long contact wipe and in excess of 40 grams of contact force at minimum operating deflection. All combined, this connector is rated at an unbelievable 5000 mating cycles for mechanical endurance.

### APPLICATIONS

- Low profile power, signal, ground or shielding requirements
- Repeatable/Pluggable module or battery pack requirements
- Low profile flex circuit to PCB applications

### FEATURES AND BENEFITS

- High Reliability / High Cycle Life BeCu contacts for maximum system performance
- ULP 1.3mm minimum operating height with 0.7mm "Z" axis compression/tolerance range
- Gold plating supports a broad range applications based on reliability and environments
- 3 Amp contact rating over a -40°C to +105°C operating range supports a broad application spectrum

### ELECTRICAL

- Current Rating: 3 Amps/Contact
- Voltage Rating: 125VAC

### ENVIRONMENTAL

- Operating Temperature: -40°C to +105°C

### MECHANICAL

- Contact Material: Beryllium Copper
- Plating: Selective Gold over Nickel, Tin on tails
- Durability: 5,000 Cycles

### HOW TO ORDER

<b>00</b>	<b>9155</b>	<b>00X</b>	<b>10X</b>	<b>006</b>
Prefix	Series	Number of Positions 002 = 2p 003 = 3p	Low Profile 100 = No Stop 101 = Stop	Packaging Options 0.4 µm Selective Gold, Tin Tail



# BTB Compression

Series 9155-100



## 2 WAY LOW PROFILE CONNECTOR NO STOP

BATTERY PACK  
INSERTION DIRECTION

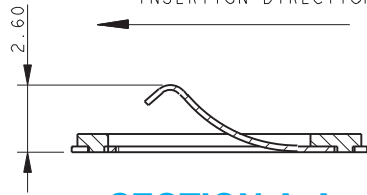

**SECTION A-A**  
CONTACT UNDEFLECTED

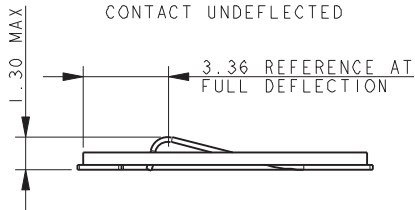

CONTACT SHOWN WITH STOP  
RESTING ON PCB

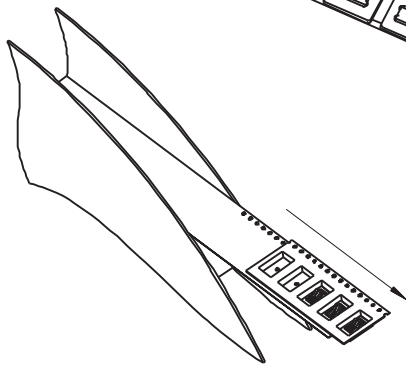
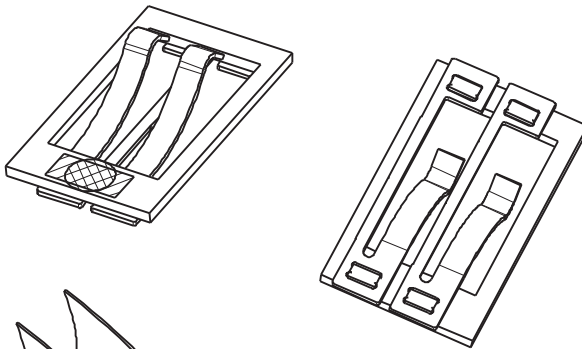

FEED DIRECTION  
OF LOADED TAPE

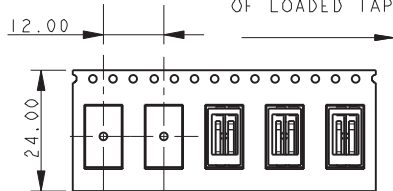

### PACKING DETAILS

REEL QTY	1500
LEADER	500MM
TRAILER	500MM

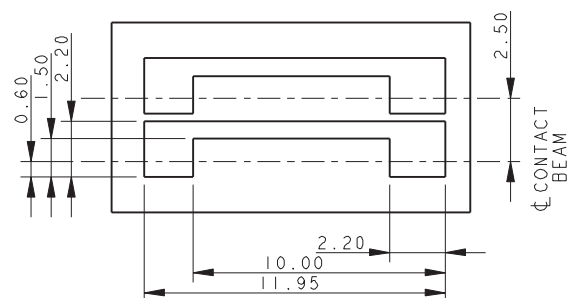
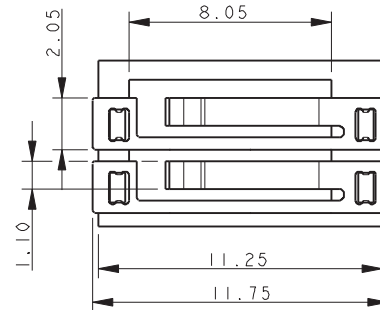
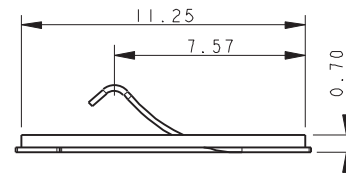
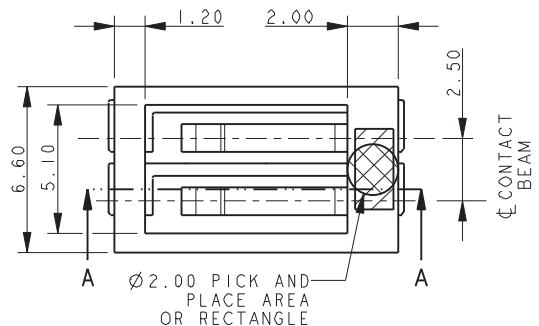

### SUGGESTED PCB LAYOUT

#### NOTES:

1. FOR FULL PRODUCT SPECIFICATION REFER TO ELCO SPECIFICATION 201-01-094.
2. MATERIALS: CONTACT - COPPER ALLOY, INSULATOR - GLASS FILLED NYLON. COLOR: BLACK.
3. TOLERANCE  $\pm 0.20$  UNLESS SPECIFIED.
4. PACKING DETAILS SEE TABLE.
5. FOR MATING PAD DETAILS REFER TO PAGE 103.



# BTB Compression

Series 9155-100



## 3 WAY LOW PROFILE CONNECTOR NO STOP

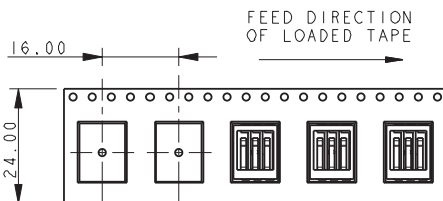
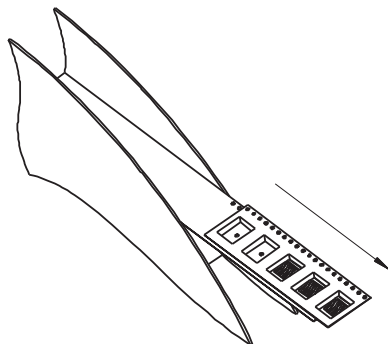
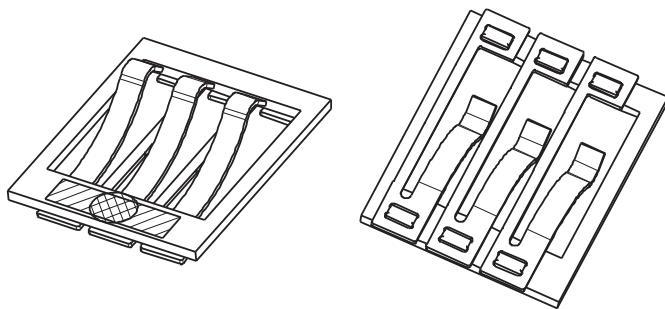
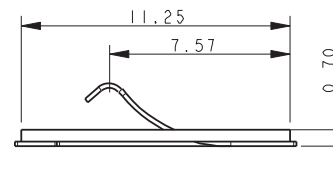
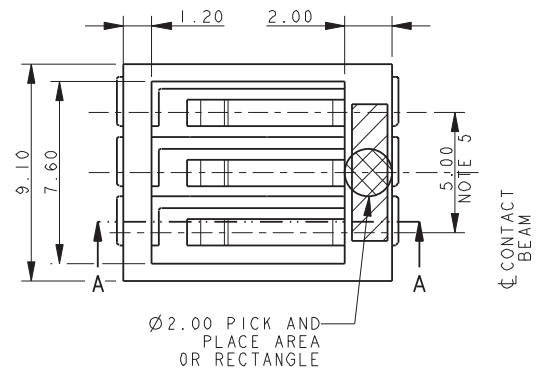
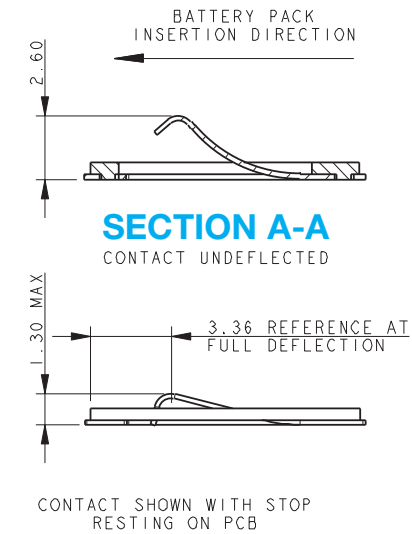

### PACKING DETAILS

REEL QTY	1200
LEADER	500MM
TRAILER	500MM

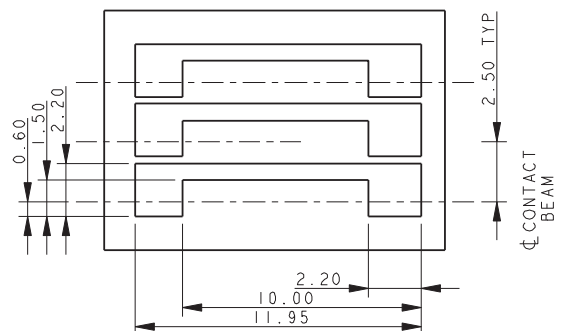
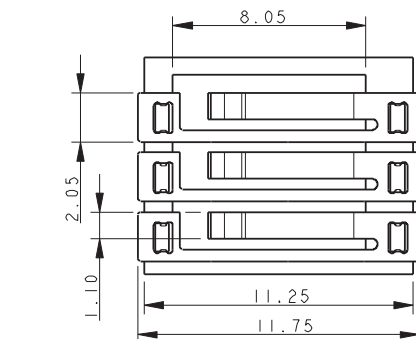

### SUGGESTED PCB LAYOUT

#### NOTES:

1. FOR FULL PRODUCT SPECIFICATION REFER TO ELCO SPECIFICATION 201-01-094.
2. MATERIALS: CONTACT - COPPER ALLOY, INSULATOR - GLASS FILLED NYLON. COLOR: BLACK.
3. TOLERANCE  $\pm 0.20$  UNLESS SPECIFIED.
4. PACKING DETAILS SEE TABLE.
5. 2 EQUAL PITCHES @ 2.50 = 5.00.
6. FOR MATING PAD DETAILS REFER TO PAGE 103.



# BTB Compression

Series 9155-100



## 2 WAY LOW PROFILE CONNECTOR WITH STOP

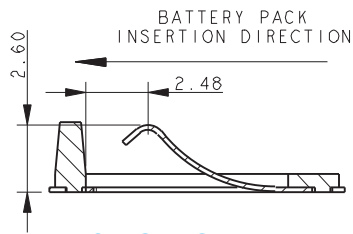

**SECTION A-A**  
CONTACT UNDEFLECTED

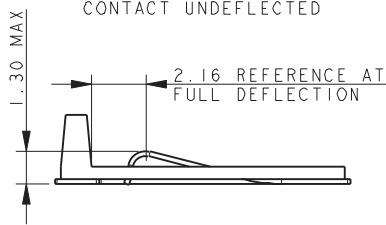

CONTACT SHOWN WITH STOP  
RESTING ON PCB

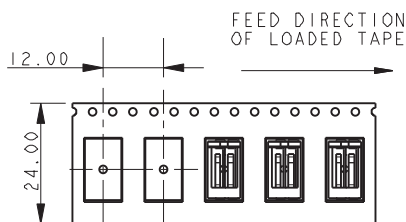
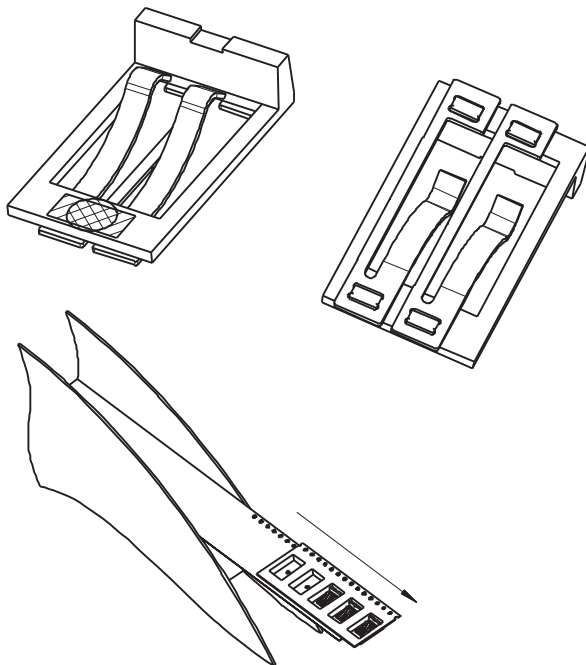

### PACKING DETAILS

REEL QTY	1500
LEADER	500MM
TRAILER	500MM

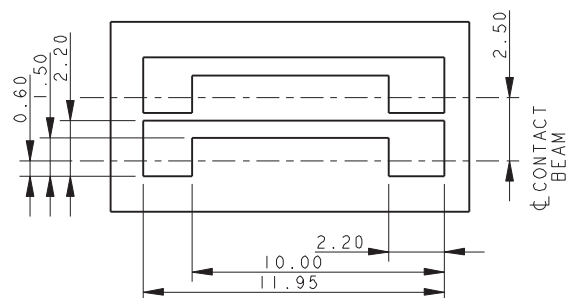
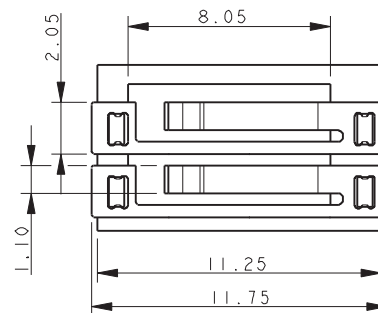
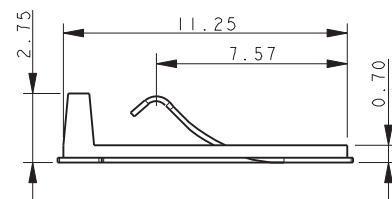
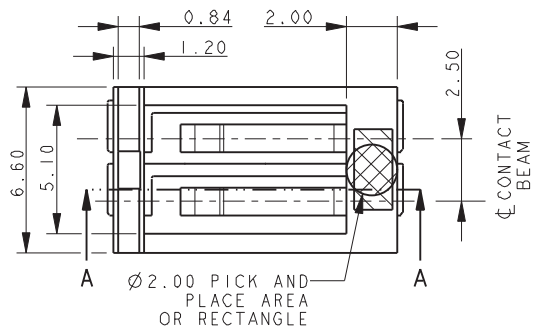

### SUGGESTED PCB LAYOUT

#### NOTES:

1. FOR FULL PRODUCT SPECIFICATION REFER TO ELCO SPECIFICATION 201-01-094.
2. MATERIALS: CONTACT - COPPER ALLOY, INSULATOR - GLASS FILLED NYLON. COLOR: BLACK.
3. TOLERANCE  $\pm 0.20$  UNLESS SPECIFIED.
4. PACKING DETAILS SEE TABLE.
5. FOR MATING PAD DETAILS REFER TO PAGE 103.



# BTB Compression

Series 9155-100



## 3 WAY LOW PROFILE CONNECTOR WITH STOP

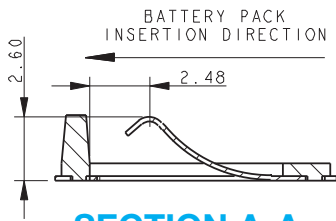

**SECTION A-A**  
CONTACT UNDEFLECTED

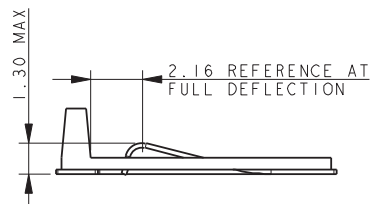

CONTACT SHOWN WITH STOP RESTING ON PCB

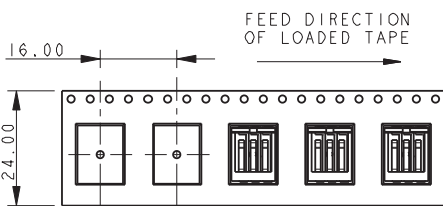
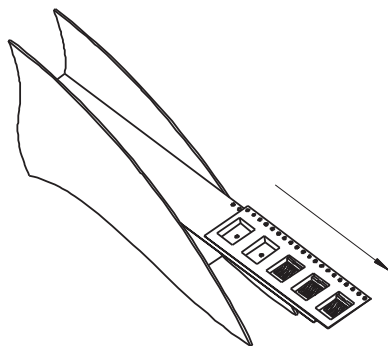
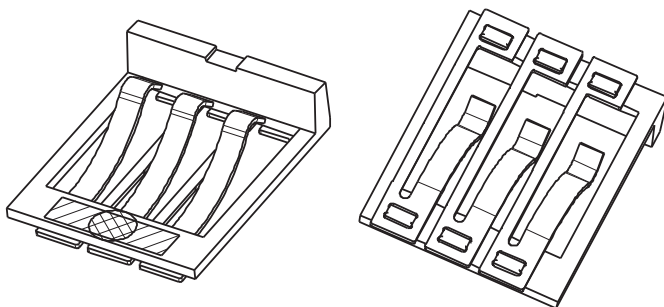

### PACKING DETAILS

REEL QTY	1200
LEADER	500MM
TRAILER	500MM

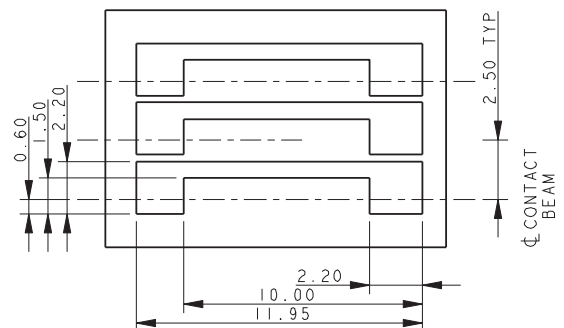
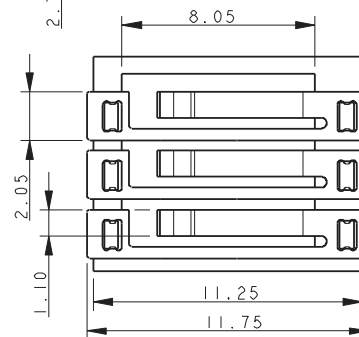
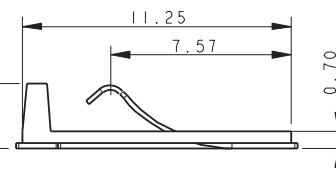
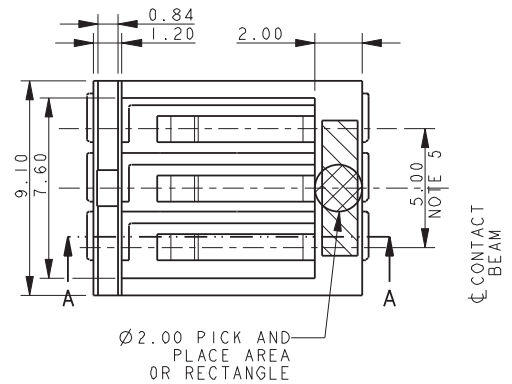

### SUGGESTED PCB LAYOUT

- NOTES:
1. FOR FULL PRODUCT SPECIFICATION REFER TO ELCO SPECIFICATION 201-01-094.
  2. MATERIALS: CONTACT - COPPER ALLOY, INSULATOR - GLASS FILLED NYLON. COLOR: BLACK.
  3. TOLERANCE  $\pm 0.20$  UNLESS SPECIFIED.
  4. PACKING DETAILS SEE TABLE.
  5. 2 EQUAL PITCHES @ 2.50 = 5.00.
  6. FOR MATING PAD DETAILS REFER TO PAGE 103.





### LOW PROFILE MATING PADS

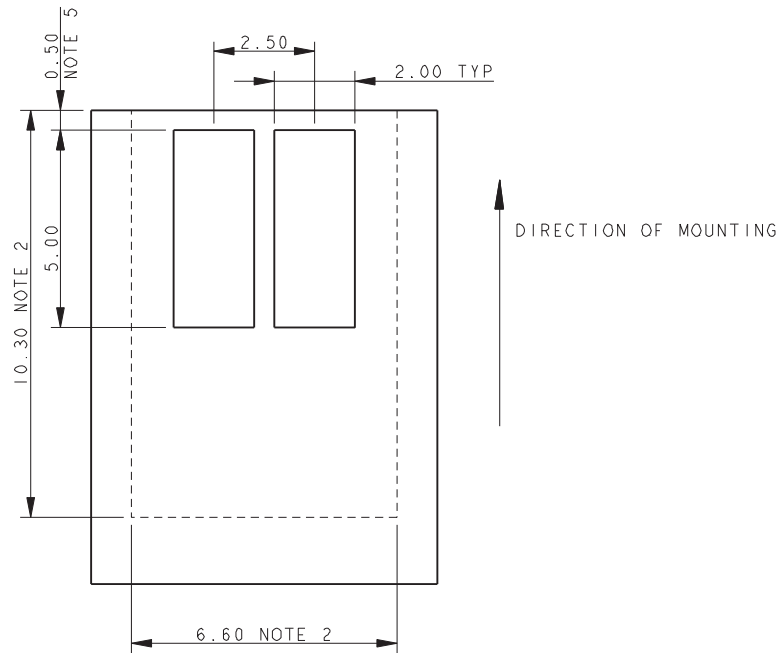

### 2 WAY MATING PADS

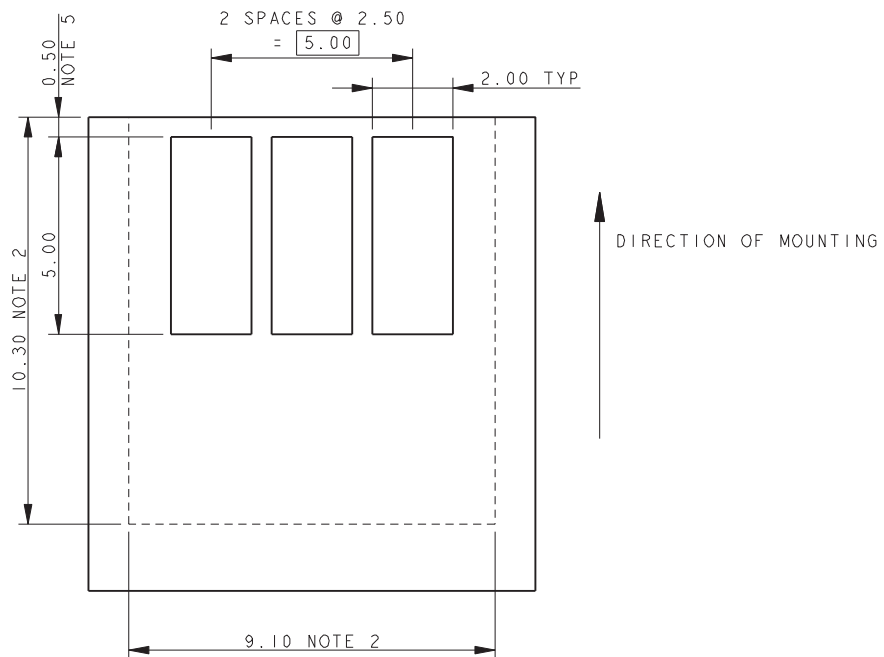

### 3 WAY MATING PADS

#### NOTES:

1. SUGGESTED MATING PADS FOR LOW PROFILE BATTERY CONNECTORS.
2. OUTLIE OF CONNECTOR.
3. PROFERED PLATING ON PADS GOLD OVER NICKEL.
4. REFERENCE DIMENSIONS.
5. DIMENSION TO EDGE OF BOARD FOR CONNECTORS WITH STOP.

# Single Compression Contact: Board-to-Board (BTB)



## Series 70-9155



Designers for ruggedized connectors to meet harsh environments continue to look for new products which will reduce size and cost without jeopardizing performance. The new Ultra-Low Profile (ULP) compression contact from AVX surface mounts to a PCB and provides a reliable compression connection to the mating board, even under extreme shock and vibration applications. With over 20 years of 1-Piece compression contact experience, this innovative contact offers full connector performance functionality at the individual contact level. Thus, allowing single contacts to be placed in any location or position on a PCB.

The high force beryllium copper contact is gold plated to maximize reliability and signal integrity. The current offering has two contacts with nominal heights of 1.0mm and 1.5mm. Add in the “Z” axis tolerance range and the compressed height covers 0.75mm up to 1.75mm. The contacts are supplied in tape and reel for easy SMT placement.

### APPLICATIONS

- Industrial/Ruggedized handheld or portable devices
- BTB connection for any traditional power or signal application
- Ground connections between PCB's or housings

### FEATURES AND BENEFITS

- Reliable gold plated Beryllium Copper contacts for high cycle life and signal integrity up to 1000 cycles
- Tape and reel packaged for automated SMT placement
- Sweeping beam design for pluggable/module applications
- Three gold plating options to match end product environmental or expected life requirements

### ELECTRICAL

- Current Rating: 3 Amps
- Voltage Rating: Based on placement distance

### ENVIRONMENTAL

- Operating Temperature: -40°C to +125°C

### MECHANICAL

- Contact Material: Beryllium Copper
- Contact Plating: Gold over Nickel
- Durability: 50, 500 and 1000 cycles

### HOW TO ORDER



**6XX**

#### Contact Description

Code	Nominal Operating Height	Contact Operating Height Range
610	1.00mm	0.75mm to 1.25mm
615	1.50mm	1.25mm to 1.75mm

**00X**

#### Contact Description

Code	Gold Thickness	Description	Availability
004	0.1µm	Nickel under Plate, Gold on Nose Tin on Remainder	Standard
006	0.4µm	Nickel under Plate, Gold on Nose Tin on Remainder	Special Order
008	0.8µm	Nickel under Plate, Gold on Nose Tin on Remainder	Special Order



# Single Compression Contact: Board-to-Board (BTB)



Series 70-9155

## 70-9155-001-610-006 NOMINAL WORKING HEIGHT 1.00MM

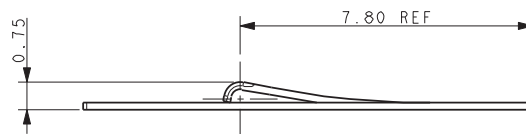
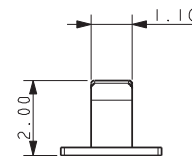
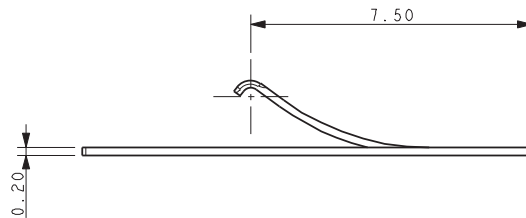
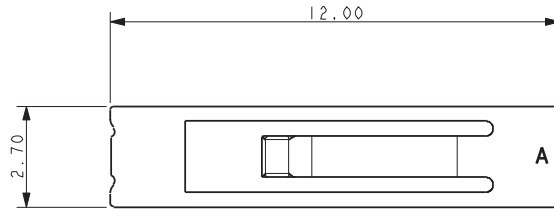

**FULLY DEFLECTED  
CONTACT**

### SUGGESTED MATING PCB LAYOUT

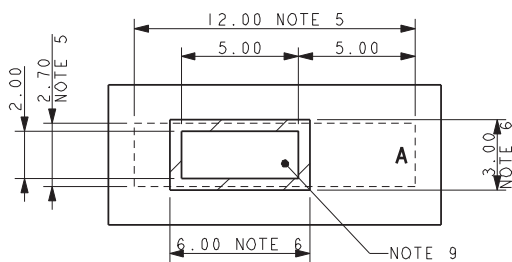

**NOTES:**

1. 9155 LOW PROFILE CONTACT, WORKING HEIGHT 0.75MM TO 1.25MM.
2. FOR FULL DETAILS REFER TO PRODUCT SPECIFICATION 201-01-153 AND APPLICATIONS NOTES 201-01-154.
3. MATERIAL: COPPER ALLOY 0.2MM THICK.
4. PLATING: NICKEL ALL OVER WITH GOLD ON CONTACT NOSE AND TIN ON THE REMAINDER. PARTS TO BE PACKED IN TAPE AND REEL. QTY PER REEL 3000.
5. OUTLINE OF CONNECTOR, ORIENTATION END "A".
6. AREA TO BE KEPT FREE OF SOLDER RESIST, FURTHER INFORMATION IN APPLICATION NOTES.
7. AREA BETWEEN PADS TO BE KEPT CLEAR OF TRACKS AND COMPONENTS.
8. SMT PADS PLATED TIN.
9. MATING PAD PLATED GOLD OVER NICKEL.

### SUGGESTED SMT PCB LAYOUT

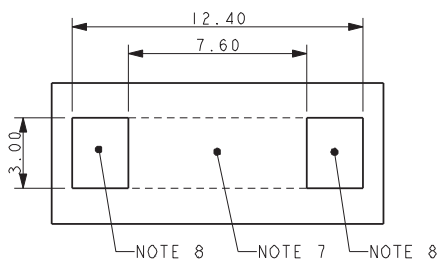

### PACKING DETAILS

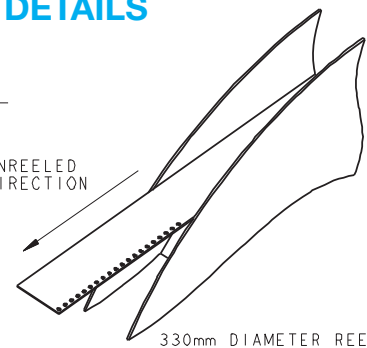
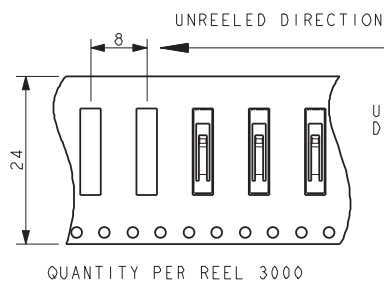

# Single Compression Contact: Board-to-Board (BTB)



Series 70-9155

## 70-9155-001-610-006 NOMINAL WORKING HEIGHT 1.50MM

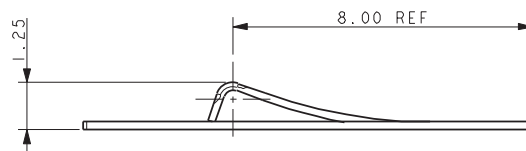
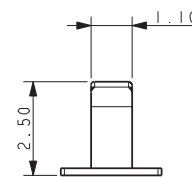
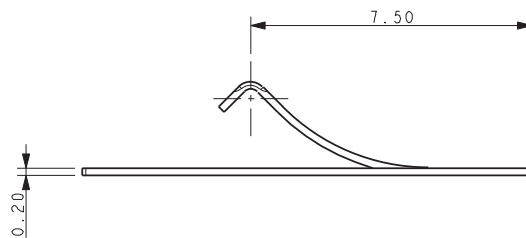
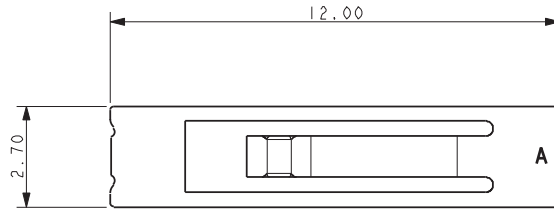

**FULLY DEFLECTED  
CONTACT**

### SUGGESTED MATING PCB LAYOUT

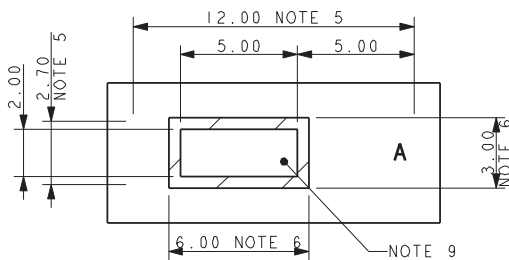

**NOTES:**

1. 9155 LOW PROFILE CONTACT, WORKING HEIGHT 0.75MM TO 1.25MM.
2. FOR FULL DETAILS REFER TO PRODUCT SPECIFICATION 201-01-153 AND APPLICATIONS NOTES 201-01-154.
3. MATERIAL: COPPER ALLOY 0.2MM THICK.
4. PLATING: NICKEL ALL OVER WITH GOLD ON CONTACT NOSE AND TIN ON THE REMAINDER. PARTS TO BE PACKED IN TAPE AND REEL. QTY PER REEL 3000.
5. OUTLINE OF CONNECTOR, ORIENTATION END "A".
6. AREA TO BE KEPT FREE OF SOLDER RESIST, FURTHER INFORMATION IN APPLICATION NOTES.
7. AREA BETWEEN PADS TO BE KEPT CLEAR OF TRACKS AND COMPONENTS.
8. SMT PADS PLATED TIN.
9. MATING PAD PLATED GOLD OVER NICKEL.

### SUGGESTED SMT PCB LAYOUT

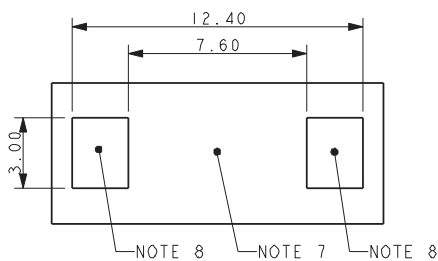

### PACKING DETAILS

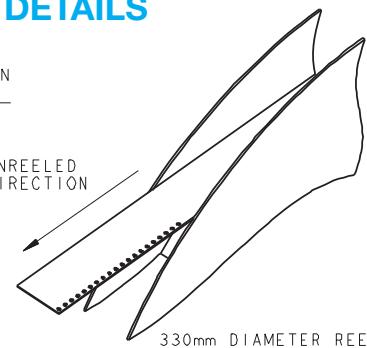
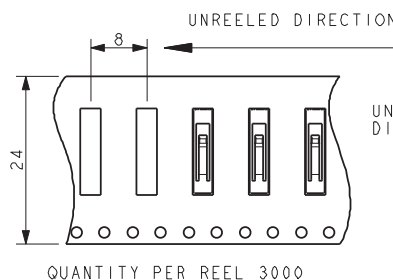

## AMERICAS

**AVX Greenville, SC**  
Tel: 864-967-2150

**AVX Northwest, WA**  
Tel: 360-699-8746

**AVX Midwest, IN**  
Tel: 317-861-9184

**AVX Mid/Pacific, CA**  
Tel: 408-988-4900

**AVX Northeast, MA**  
Tel: 617-479-0345

**AVX Southwest, CA**  
Tel: 949-859-9509

**AVX Canada**  
Tel: 905-238-3151

**AVX South America**  
Tel: +55-11-4688-1960

## EUROPE

**AVX Limited, England**  
Tel: +44-1276-697000

**AVX S.A.S., France**  
Tel: +33-1-69-18-46-00

**AVX GmbH, Germany**  
Tel: +49-0811-95949-0

**AVX SRL, Italy**  
Tel: +39-02-614-571

**AVX Czech Republic**  
Tel: +420-57-57-57-521

**AVX/ELCO UK**  
Tel: +44-1638-675000

**ELCO Europe GmbH**  
Tel: +49-2741-299-0

**AVX S.A., Spain**  
Tel: +34-91-63-97-197

**AVX Benelux**  
Tel: +31-187-489-337

## ASIA-PACIFIC

**AVX/Kyocera (S) Pte Ltd.,  
Singapore**  
Tel: +65-6286-7555

**AVX/Kyocera, Asia, Ltd.,  
Hong Kong**  
Tel: +852-2363-3303

**AVX/Kyocera Yuhan Hoesa,  
South Korea**  
Tel: +82-2785-6504

**AVX/Kyocera HK Ltd.,  
Taiwan**  
Tel: +886-2-2656-0258

**AVX/Kyocera (M) Sdn Bhd,  
Malaysia**  
Tel: +60-4228-1190

**AVX/Kyocera International  
Trading Co. Ltd.,  
Shanghai**  
Tel: +86-21-3255 1933

**AVX/Kyocera Asia Ltd.,  
Shenzen**  
Tel: +86-755-3336-0615

**AVX/Kyocera International  
Trading Co. Ltd.,  
Beijing**  
Tel: +86-10-6588-3528

**AVX/Kyocera India  
Liaison Office**  
Tel: +91-80-6450-0715

## ASIA-KED

(KYOCERA Electronic Devices)

**KED Hong Kong Ltd.**  
Tel: +852-2305-1080/1223

**KED Hong Kong Ltd.  
Shenzen**  
Tel: +86-755-3398-9600

**KED Company Ltd.  
Shanghai**  
Tel: +86-21-3255-1833

**KED Hong Kong Ltd.  
Beijing**  
Tel: +86-10-5869-4655

**KED Taiwan Ltd.**  
Tel: +886-2-2950-0268

**KED Korea Yuhan Hoesa,  
South Korea**  
Tel: +82-2-783-3604/6126

**KED (S) Pte Ltd.  
Singapore**  
Tel: +65-6509-0328

**Kyocera Corporation  
Japan**  
Tel: +81-75-604-3449

**Contact:**



<http://www.avx.com>

S-BTB0M1213-C

Компания «Океан Электроники» предлагает заключение долгосрочных отношений при поставках импортных электронных компонентов на взаимовыгодных условиях!

Наши преимущества:

- Поставка оригинальных импортных электронных компонентов напрямую с производств Америки, Европы и Азии, а так же с крупнейших складов мира;
- Широкая линейка поставок активных и пассивных импортных электронных компонентов (более 30 млн. наименований);
- Поставка сложных, дефицитных, либо снятых с производства позиций;
- Оперативные сроки поставки под заказ (от 5 рабочих дней);
- Экспресс доставка в любую точку России;
- Помощь Конструкторского Отдела и консультации квалифицированных инженеров;
- Техническая поддержка проекта, помощь в подборе аналогов, поставка прототипов;
- Поставка электронных компонентов под контролем ВП;
- Система менеджмента качества сертифицирована по Международному стандарту ISO 9001;
- При необходимости вся продукция военного и аэрокосмического назначения проходит испытания и сертификацию в лаборатории (по согласованию с заказчиком);
- Поставка специализированных компонентов военного и аэрокосмического уровня качества (Xilinx, Altera, Analog Devices, Intersil, Interpoint, Microsemi, Actel, Aeroflex, Peregrine, VPT, Syfer, Eurofarad, Texas Instruments, MS Kennedy, Miteq, Cobham, E2V, MA-COM, Hittite, Mini-Circuits, General Dynamics и др.);

Компания «Океан Электроники» является официальным дистрибьютором и эксклюзивным представителем в России одного из крупнейших производителей разъемов военного и аэрокосмического назначения «JONHON», а так же официальным дистрибьютором и эксклюзивным представителем в России производителя высокотехнологичных и надежных решений для передачи СВЧ сигналов «FORSTAR».



## JONHON

«JONHON» (основан в 1970 г.)

Разъемы специального, военного и аэрокосмического назначения:

(Применяются в военной, авиационной, аэрокосмической, морской, железнодорожной, горно- и нефтедобывающей отраслях промышленности)

«FORSTAR» (основан в 1998 г.)

ВЧ соединители, коаксиальные кабели,  
кабельные сборки и микроволновые компоненты:

(Применяются в телекоммуникациях гражданского и специального назначения, в средствах связи, РЛС, а так же военной, авиационной и аэрокосмической отраслях промышленности).



Телефон: 8 (812) 309-75-97 (многоканальный)

Факс: 8 (812) 320-03-32

Электронная почта: [ocean@oceanchips.ru](mailto:ocean@oceanchips.ru)

Web: <http://oceanchips.ru/>

Адрес: 198099, г. Санкт-Петербург, ул. Калинина, д. 2, корп. 4, лит. А