

GENERAL DESCRIPTION

The 83947I is a low skew, 1-to-9 LVCMOS Fanout Buffer. The low impedance LVCMOS/LVTTL outputs are designed to drive 50Ω series or parallel terminated transmission lines. The effective fanout can be increased from 9 to 18 by utilizing the ability of the outputs to drive two series terminated lines.

Guaranteed output and part-to-part skew characteristics make the 83947I ideal for high performance, single ended applications that also require a limited output voltage.

FEATURES

- 9 LVCMOS/LVTTL outputs
- Selectable CLK0 and CLK1 can accept the following input levels: LVCMOS and LVTTL
- Maximum output frequency: 110MHz
- Output skew: 500ps (maximum)
- Part-to-part skew: 2ns (maximum)
- 3.3V operating supply
- -40°C to 85°C ambient operating temperature
- Lead-Free package available

BLOCK DIAGRAM

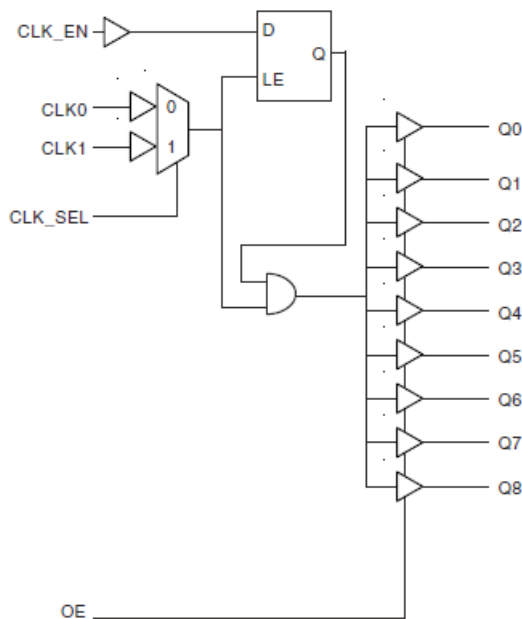

PIN ASSIGNMENT

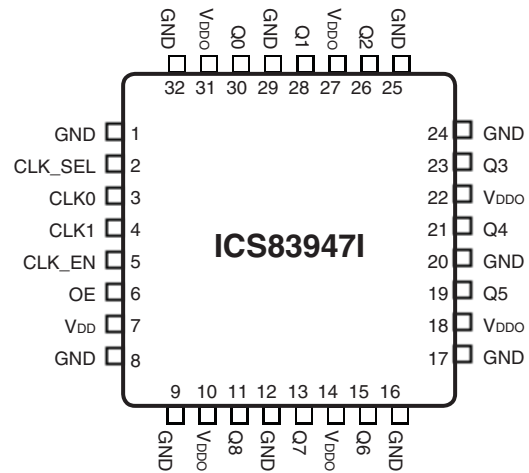

32-Lead LQFP
7mm x 7mm x 1.4mm package body
Y Package
Top View

TABLE 1. PIN DESCRIPTIONS

Number	Name	Type		Description
1, 8, 9, 12, 16, 17, 20, 24, 25, 29, 32	GND	Power		Power supply ground.
2	CLK_SEL	Input	Pullup	Clock select input. When HIGH, selects CLK1. When LOW, selects CLK0. LVCMOS / LVTTTL interface levels.
3, 4	CLK0, CLK1	Input	Pullup	Reference clock inputs. LVCMOS / LVTTTL interface levels.
5	CLK_EN	Input	Pullup	Clock enable. LVCMOS / LVTTTL interface levels.
6	OE	Input	Pullup	Output enable. LVCMOS / LVTTTL interface levels.
7	V _{DD}	Power		Core supply pin.
10, 14, 18, 22, 27, 31	V _{DDO}	Power		Output supply pins.
11, 13, 15, 19, 21, 23, 26, 28, 30	Q8, Q7, Q6, Q5, Q4, Q3, Q2, Q1, Q0	Output		Q0 thru Q8 clock outputs. LVCMOS / LVTTTL interface levels.

NOTE: *Pullup* refers to internal input resistors. See Table 2, Pin Characteristics, for typical values.

TABLE 2. PIN CHARACTERISTICS

Symbol	Parameter	Test Conditions	Minimum	Typical	Maximum	Units
C _{IN}	Input Capacitance			4		pF
C _{PD}	Power Dissipation Capacitance (per output)			25		pF
R _{PULLUP}	Input Pullup Resistor			51		KΩ
R _{PULLDOWN}	Input Pulldown Resistor			51		KΩ
R _{OUT}	Output Impedance		5	7	12	Ω

TABLE 3. OUTPUT ENABLE AND CLOCK ENABLE FUNCTION TABLE

Control Inputs		Output
OE	CLK_EN	Q0:Q8
0	X	Hi-Z
1	0	LOW
1	1	Follows CLK input

ABSOLUTE MAXIMUM RATINGS

Supply Voltage, V_{DD}	4.6V
Inputs, V_I	-0.5V to $V_{DD} + 0.5V$
Outputs, V_O	-0.5V to $V_{DDO} + 0.5V$
Package Thermal Impedance, θ_{JA}	47.9°C/W (0 lfm)
Storage Temperature, T_{STG}	-65°C to 150°C

NOTE: Stresses beyond those listed under Absolute Maximum Ratings may cause permanent damage to the device. These ratings are stress specifications only. Functional operation of product at these conditions or any conditions beyond those listed in the *DC Characteristics* or *AC Characteristics* is not implied. Exposure to absolute maximum rating conditions for extended periods may affect product reliability.

TABLE 4A. POWER SUPPLY DC CHARACTERISTICS, $V_{DD} = V_{DDO} = 3.3V \pm 0.3V$, $T_A = -40^\circ\text{C}$ TO 85°C

Symbol	Parameter	Test Conditions	Minimum	Typical	Maximum	Units
V_{DD}	Coret Supply Voltage		3.0	3.3	3.6	V
V_{DDO}	Output Supply Voltage		3.0	3.3	3.6	V
I_{DD}	Input Supply Current			33	50	mA

TABLE 4B. LVCMOS/LVTTL DC CHARACTERISTICS, $V_{DD} = V_{DDO} = 3.3V \pm 0.3V$, $T_A = -40^\circ\text{C}$ TO 85°C

Symbol	Parameter	Test Conditions	Minimum	Typical	Maximum	Units
V_{IH}	Input High Voltage		2		3.6	V
V_{IL}	Input Low Voltage				0.8	V
I_{IN}	Input Current	CLK0, CLK1, CLK_SEL, OE, CLK_EN	-100			μA
V_{OH}	Output High Voltage	$I_{OH} = -20\text{mA}$	2.5			V
V_{OL}	Output Low Voltage	$I_{OL} = 20\text{mA}$			0.4	V

TABLE 5. AC CHARACTERISTICS, $V_{DD} = V_{DDO} = 3.3V \pm 0.3V$, $T_A = -40^{\circ}C$ TO $85^{\circ}C$

Symbol	Parameter	Test Conditions	Minimum	Typical	Maximum	Units
f_{MAX}	Output Frequency		110			MHz
t_{PD}	Propagation Delay, NOTE 1	CLK to Q	1.8		4.5	ns
tsk(o)	Output Skew; NOTE 2, 5	Measured on rising edge @ $V_{DDO}/2$			500	ps
tsk(pp)	Part-to-Part Skew; NOTE 3, 5	Measured on rising edge @ $V_{DDO}/2$			2	ns
t_{PW}	Output Pulse Width		tPeriod/2 - 800		tPeriod/2 + 800	ps
t_S	Clock Enable Setup Time; NOTE 6	CLK_EN to CLK	0			ns
t_H	Clock Enable Hold Time; NOTE 6	CLK_EN to CLK	1			ns
t_{ZL}, t_{ZH}	Output Enable Time; NOTE 4				11	ns
t_{LZ}, t_{HZ}	Output Disable Time; NOTE 4				11	ns
t_R	Output Rise Time	0.8V to 2.0V	0.2		1	ns
t_F	Output Fall Time	0.8V to 2.0V	0.2		1	ns

All parameters measured at f_{MAX} unless noted otherwise.

NOTE 1: Measured from $V_{DD}/2$ of the input to $V_{DDO}/2$ of the output.

NOTE 2: Defined as skew between outputs at the same supply voltage and with equal load conditions.

Measured at $V_{DDO}/2$.

NOTE 3: Defined as skew between outputs on different devices operating at the same supply voltages and with equal load conditions. Using the same type of inputs on each device, the outputs are measured at $V_{DDO}/2$.

NOTE 4: These parameters are guaranteed by characterization. Not tested in production.

NOTE 5: This parameter is defined in accordance with JEDEC Standard 65.

NOTE 6: Setup and Hold times are relative to the rising edge of the input clock.

PARAMETER MEASUREMENT INFORMATION

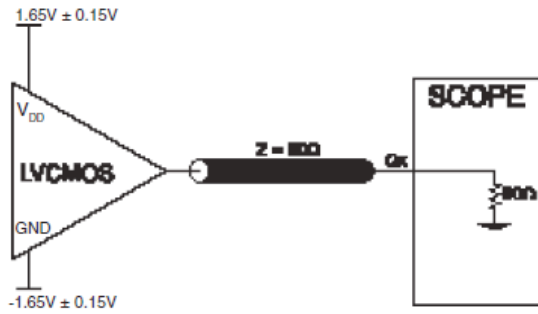
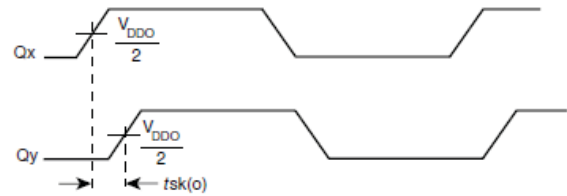
3.3V OUTPUT LOAD AC TEST CIRCUIT

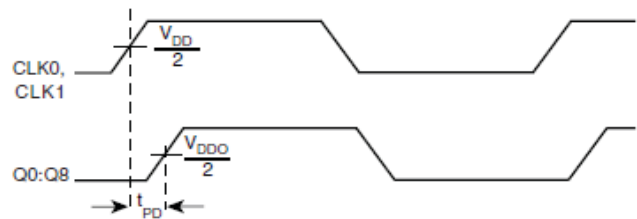
OUTPUT SKEW

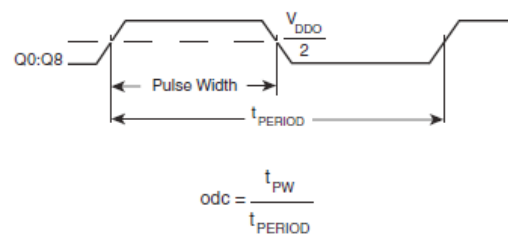
PART-TO-PART SKEW

PROPAGATION DELAY

OUTPUT RISE/FALL TIME

OUTPUT DUTY CYCLE/PULSE WIDTH/PERIOD

RELIABILITY INFORMATION

TABLE 6. θ_{JA} VS. AIR FLOW TABLE FOR 32 LEAD LQFP

θ_{JA} by Velocity (Linear Feet per Minute)			
	0	200	500
Single-Layer PCB, JEDEC Standard Test Boards	67.8°C/W	55.9°C/W	50.1°C/W
Multi-Layer PCB, JEDEC Standard Test Boards	47.9°C/W	42.1°C/W	39.4°C/W

NOTE: Most modern PCB designs use multi-layered boards. The data in the second row pertains to most designs.

TRANSISTOR COUNT

The transistor count for 83947I is: 1040

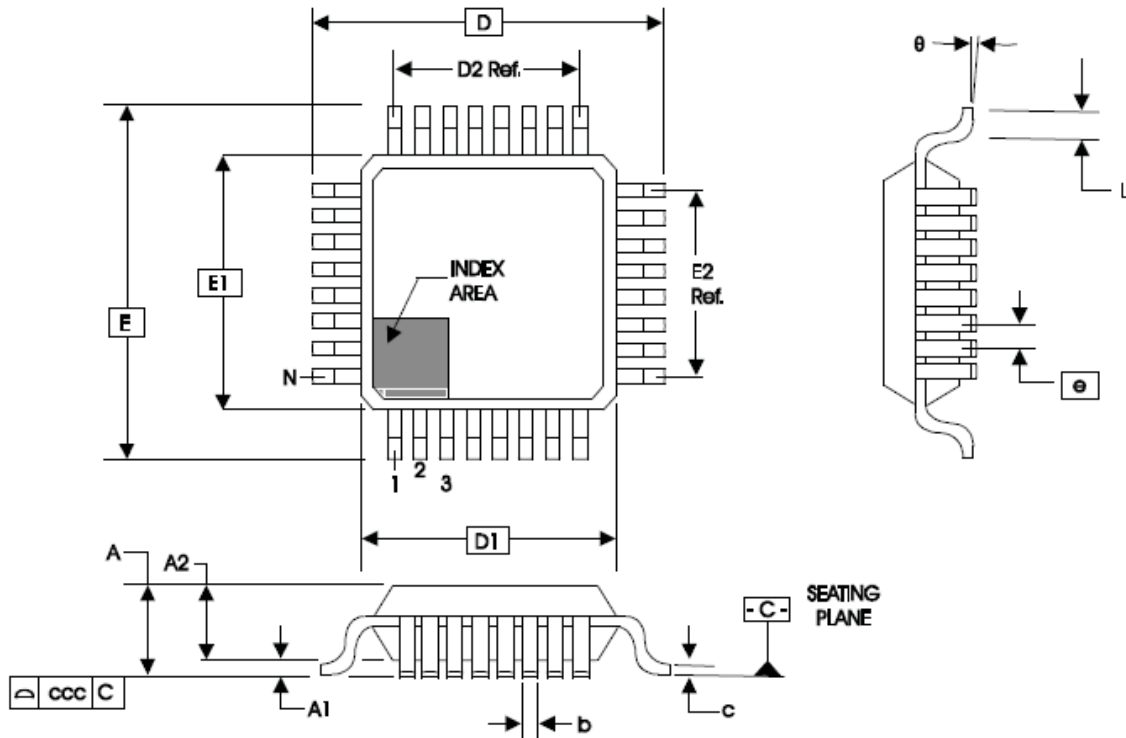
PACKAGE OUTLINE - Y SUFFIX FOR 32 LEAD LQFP

TABLE 7. PACKAGE DIMENSIONS

JEDEC VARIATION ALL DIMENSIONS IN MILLIMETERS			
SYMBOL	BBA		
	MINIMUM	NOMINAL	MAXIMUM
N	32		
A	--	--	1.60
A1	0.05	--	0.15
A2	1.35	1.40	1.45
b	0.30	0.37	0.45
c	0.09	--	0.20
D	9.00 BASIC		
D1	7.00 BASIC		
D2	5.60 Ref.		
E	9.00 BASIC		
E1	7.00 BASIC		
E2	5.60 Ref.		
e	0.80 BASIC		
L	0.45	0.60	0.75
θ	0°	--	7°
ccc	--	--	0.10

Reference Document: JEDEC Publication 95, MS-026

TABLE 8. ORDERING INFORMATION

Part/Order Number	Marking	Package	Shipping Packaging	Temperature
83947AYILN	ICS3947AYIN	32 Lead "Lead-Free/Annealed" LQFP	tray	-40°C to 85°C
83947AYILNT	ICS3947AYIN	32 Lead "Lead-Free/Annealed" LQFP	Tape & Reel	-40°C to 85°C

REVISION HISTORY SHEET				
Rev	Table	Page	Description of Change	Date
A	T5	4	AC Characteristics Table, t_s and t_H rows- revised Test Conditions to read CLK_EN to CLK.	6/21/02
B	T2	1	Added Lead Free bullet in Features section.	10/11/04
		2	Pin Characteristics Table - changed C_{IN} from 4pF max. to 4pF min. R_{OUT} added 5 Ω min and 12 Ω max.	
		8	Ordering Information Table - add Lead-Free part. Updated format throughout data sheet.	
B	T8	8	Updated datasheet's header/footer with IDT from ICS.	8/9/10
		10	Removed ICS prefix from Part/Order Number column. Added Contact Page.	
B	T8	8	Updated datasheet format Ordering information - removed leaded part numbers - PDN CQ-13-02 expired	11/10/14
B			Removed ICS from part number where needed. Updated header and footer.	3/17/16



Corporate Headquarters
6024 Silver Creek Valley Road
San Jose, CA 95138 USA
www.IDT.com

Sales
1-800-345-7015 or 408-284-8200
Fax: 408-284-2775
www.IDT.com/go/sales

Tech Support
www.idt.com/go/support

DISCLAIMER Integrated Device Technology, Inc. (IDT) reserves the right to modify the products and/or specifications described herein at any time, without notice, at IDT's sole discretion. Performance specifications and operating parameters of the described products are determined in an independent state and are not guaranteed to perform the same way when installed in customer products. The information contained herein is provided without representation or warranty of any kind, whether express or implied, including, but not limited to, the suitability of IDT's products for any particular purpose, an implied warranty of merchantability, or non-infringement of the intellectual property rights of others. This document is presented only as a guide and does not convey any license under intellectual property rights of IDT or any third parties.

IDT's products are not intended for use in applications involving extreme environmental conditions or in life support systems or similar devices where the failure or malfunction of an IDT product can be reasonably expected to significantly affect the health or safety of users. Anyone using an IDT product in such a manner does so at their own risk, absent an express, written agreement by IDT.

Integrated Device Technology, IDT and the IDT logo are trademarks or registered trademarks of IDT and its subsidiaries in the United States and other countries. Other trademarks used herein are the property of IDT or their respective third party owners.

For datasheet type definitions and a glossary of common terms, visit www.idt.com/go/glossary.

Copyright ©2016 Integrated Device Technology, Inc. All rights reserved.

Компания «Океан Электроники» предлагает заключение долгосрочных отношений при поставках импортных электронных компонентов на взаимовыгодных условиях!

Наши преимущества:

- Поставка оригинальных импортных электронных компонентов напрямую с производств Америки, Европы и Азии, а так же с крупнейших складов мира;
- Широкая линейка поставок активных и пассивных импортных электронных компонентов (более 30 млн. наименований);
- Поставка сложных, дефицитных, либо снятых с производства позиций;
- Оперативные сроки поставки под заказ (от 5 рабочих дней);
- Экспресс доставка в любую точку России;
- Помощь Конструкторского Отдела и консультации квалифицированных инженеров;
- Техническая поддержка проекта, помощь в подборе аналогов, поставка прототипов;
- Поставка электронных компонентов под контролем ВП;
- Система менеджмента качества сертифицирована по Международному стандарту ISO 9001;
- При необходимости вся продукция военного и аэрокосмического назначения проходит испытания и сертификацию в лаборатории (по согласованию с заказчиком);
- Поставка специализированных компонентов военного и аэрокосмического уровня качества (Xilinx, Altera, Analog Devices, Intersil, Interpoint, Microsemi, Actel, Aeroflex, Peregrine, VPT, Syfer, Eurofarad, Texas Instruments, MS Kennedy, Miteq, Cobham, E2V, MA-COM, Hittite, Mini-Circuits, General Dynamics и др.);

Компания «Океан Электроники» является официальным дистрибьютором и эксклюзивным представителем в России одного из крупнейших производителей разъемов военного и аэрокосмического назначения «JONHON», а так же официальным дистрибьютором и эксклюзивным представителем в России производителя высокотехнологичных и надежных решений для передачи СВЧ сигналов «FORSTAR».



JONHON

«JONHON» (основан в 1970 г.)

Разъемы специального, военного и аэрокосмического назначения:

(Применяются в военной, авиационной, аэрокосмической, морской, железнодорожной, горно- и нефтедобывающей отраслях промышленности)

«FORSTAR» (основан в 1998 г.)

ВЧ соединители, коаксиальные кабели, кабельные сборки и микроволновые компоненты:

(Применяются в телекоммуникациях гражданского и специального назначения, в средствах связи, РЛС, а так же военной, авиационной и аэрокосмической отраслях промышленности).



Телефон: 8 (812) 309-75-97 (многоканальный)

Факс: 8 (812) 320-03-32

Электронная почта: ocean@oceanchips.ru

Web: <http://oceanchips.ru/>

Адрес: 198099, г. Санкт-Петербург, ул. Калинина, д. 2, корп. 4, лит. А