

## 19 mm Series

### Low Cost, Stainless Steel, Isolated Pressure Sensors



#### DESCRIPTION

Honeywell's stainless steel 19C, 19U, and 19 Vacuum Gage Series sensors were developed for pressure applications that involve measurement of hostile media in harsh environments compatible with 316 stainless steel. The special Vacuum Gage Series sensors are specifically designed for applications that can be exposed to vacuum.

The 19C Series are calibrated and temperature compensated. They are available for use with either a constant voltage or current source.

#### FEATURES

- Low cost
- Rugged, isolated stainless steel package
- Small size
- Reliable semiconductor technology
- Calibrated and temperature compensated
- Absolute and gage pressures
- Vacuum compatible, isolated sensors
- 0 psi to 3 psi to, 0 psi to 500 psi

They feature a variety of pressure connections to allow use in a wide range of OEM (Original Equipment Manufacturer) equipment. The 19U Series is uncompensated for applications that use their own specialized circuit designs.

The 19C and 19U Series sensors are rugged and reliable transducers for use in a wide variety of pressure sensing applications where corrosive liquids or gases are monitored.

#### POTENTIAL APPLICATIONS

- Industrial controls
- Process control systems
- Industrial automation and flow control
- Pressure calibrators

# 19 mm Series

## PRESSURE SENSOR CHARACTERISTICS (All Devices)

Environmental Specifications	
Compensated temperature range	0 °C to 82 °C [32 °F to 180 °F]
Operating temperature range	-40 °C to 125 °C [-40 °F to 257 °F]
Storage temperature range	-40 °C to 125 °C [-40 °F to 257 °F]
Vibration	10 G at 20 Hz to 2000 Hz
Shock	100 G for 11 ms
Life	1 million cycles min.
Insulation resistance	100 mΩ at 50 Vdc
Maximum Ratings	
Voltage version "K"	supply voltage $V_s = +15$ Vdc
Voltage version "L"	supply current $I_s = +2.0$ mA

## PRESSURE RANGE SPECIFICATIONS (19C, 19U)

Catalog Listing	Pressure Range	Proof Pressure <sup>(7)</sup>	Burst Pressure <sup>(8)</sup>
19(C,U) 003P G (1...9) (K/L)	0 psig to 3 psig	9 psig	15 psig
19(C,U) 005P G (1...9) (K/L)	0 psig to 5 psig	15 psig	25 psig
19(C,U) 010P G (1...9) (K/L)	0 psig to 10 psig	30 psig	50 psig
19(C,U) 015P (A,G,V) (1...9) (K/L)	0 psi to 15 psi	45 psi	75 psi
19(C,U) 030P (A,G,V) (1...9) (K/L)	0 psi to 30 psi	90 psi	150 psi
19(C,U) 050P (A,G,V) (1...9) (K/L)	0 psi to 50 psi	150 psi	250 psi
19(C,U) 100P (A,G,V) (1...9) (K/L)	0 psi to 100 psi	300 psi	500 psi
19(C,U) 200P (A,G,V) (1...9) (K/L)	0 psi to 200 psi	600 psi	1000 psi
19(C,U) 300P (A,G,V) (1...9) (K/L)	0 psi to 300 psi	900 psi	1500 psi
19(C,U) 500P (A,G,V) (1...9) (K/L)	0 psi to 500 psi	1200 psi	2400 psi

## 19C SERIES PERFORMANCE CHARACTERISTICS <sup>(1)</sup>

Characteristic	Minimum	Typical	Maximum	Unit
Zero pressure offset	-2	0	2	mV
Full-scale span <sup>(2)</sup>	98	100	102	mV
Full-scale span (3 psi and 5 psi "K" units only) <sup>(2)</sup>	48	50	52	mV
Pressure non-linearity <sup>(3)</sup>	–	±0.1	±0.25	%FSS
Pressure hysteresis <sup>(3)</sup>	–	±0.015	±0.030	%FSS
Repeatability	–	±0.010	±0.030	%FSS
Temp. effect on span <sup>(4)</sup>	–	±0.5	±1.0	%FSS
Temp. effect on offset <sup>(4)</sup>	–	±0.5	±1.0	%FSS
Temp. effect on span (0 psi to 3 psi and 0 psi to 5 psi only) <sup>(4)</sup>	–	–	±2.0	%FSS
Temp. effect on offset (0 psi to 3 psi and 0 psi to 5 psi only) <sup>(4)</sup>	–	–	±2.0	%FSS
Thermal hysteresis (0 °C to 82 °C [32 °F to 180 °F])	–	±0.1	±0.3	%FSS
Long-term stability of offset and span <sup>(5)</sup>	–	±0.1	±0.3	%FSS
Response time <sup>(6)</sup>	–	0.1	–	ms
Common mode voltage (voltage version "K") <sup>(9)</sup>	0.5	1.3	2.0	Vdc
Input impedance (current version "L")	2.0	4.5	8.0	kΩ
Input impedance (voltage version "K")	8.0	25	50	kΩ
Output resistance	3.0	4.5	6.0	kΩ

# Low Cost, Stainless Steel, Pressure Sensors

## 19U SERIES PERFORMANCE CHARACTERISTICS <sup>(1)</sup>

Characteristic	Minimum	Typical	Maximum	Unit
Zero pressure offset	-7.5	1.0	7.5	mV/V
Full-scale span <sup>(2)</sup>	30	40	60	mV/V
Full-scale span (3 psi and 5 psi only) <sup>(2)</sup>	20	30	40	mV/V
Pressure non-linearity <sup>(3)</sup>	–	±0.1	±0.25	%FSS
Pressure hysteresis <sup>(3)</sup>	–	±0.015	±0.030	%FSS
Repeatability	–	±0.010	±0.030	%FSS
Temp. coefficient of resistance <sup>(10)</sup> (0 °C to 82 °C [32 °F to 180 °F])	2700	3420	4500	ppm/°C
Temp. coefficient of offset <sup>(10)</sup> (0 °C to 82 °C [32 °F to 180 °F])	–	30	–	µV/V/°C
Temp. coefficient of span <sup>(10)</sup> (0 °C to 82 °C [32 °F to 180 °F])	360	720	1620	ppm/°C
Thermal hysteresis (0 °C to 82 °C [32 °F to 180 °F])	–	±0.1	±0.3	%FSS
Long-term stability of offset and span <sup>(5)</sup>	–	±0.1	±0.3	%FSS
Response time <sup>(6)</sup>	–	±0.1	–	ms
Input resistance	4.00	4.75	6.0	kΩ
Output resistance	4.00	4.75	6.0	kΩ

## 19C VACUUM GAGE COMPENSATED SERIES PERFORMANCE CHARACTERISTICS <sup>(1)</sup>

Characteristic	Minimum	Typical	Maximum	Unit
Zero pressure offset (at 0 psig)	-2	0	2	mV
Full-scale span <sup>(2)</sup> (0 psig to positive full-scale)	98	100	102	mV
Pressure non-linearity <sup>(3)</sup>	–	±0.1	±0.25	%FSS
Pressure hysteresis <sup>(3)</sup>	–	±0.015	±0.030	%FSS
Repeatability	–	±0.010	±0.030	%FSS
Temp. effect on span <sup>(4)</sup>	–	±0.5	±1.0	%FSS
Temp. effect on offset <sup>(4)</sup>	–	±0.5	±1.0	%FSS
Thermal hysteresis (0 °C to 82 °C [32 °F to 180 °F])	–	±0.1	±0.3	%FSS
Long-term stability of offset and span <sup>(5)</sup>	–	±0.1	±0.3	%FSS
Response time <sup>(6)</sup>	–	0.1	–	ms
Common mode voltage (voltage version “K”) <sup>(9)</sup>	0.5	1.3	2.0	Vdc
Input impedance (current version “L”)	1.5	4.5	8.0	kΩ
Input impedance (voltage version “K”)	8.0	25	50	kΩ
Output resistance	3.0	4.5	6.0	kΩ

## 19U VACUUM GAGE UNCOMPENSATED SERIES PERFORMANCE CHARACTERISTICS <sup>(1)</sup>

Characteristic	Minimum	Typical	Maximum	Unit
Zero pressure offset	-7.5	1.0	7.5	mV/V
Full-scale span <sup>(2)</sup> (0 psig to positive full-scale)	30	40	60	mV/V
Pressure non-linearity <sup>(3)</sup>	–	±0.1	±0.25	%FSS
Pressure hysteresis <sup>(3)</sup>	–	±0.015	±0.030	%FSS
Repeatability	–	±0.010	±0.030	%FSS
Temp. coefficient of resistance <sup>(10)</sup> (0 °C to 82 °C [32 °F to 180 °F])	2700	3420	4500	ppm/°C
Temp. coefficient of offset <sup>(10)</sup> (0 °C to 82 °C [32 °F to 180 °F])	–	30	–	•V/V/°C
Temp. coefficient of span <sup>(10)</sup> (0 °C to 82 °C [32 °F to 180 °F])	360	720	1620	ppm/°C
Thermal hysteresis (0 °C to 82 °C [32 °F to 180 °F])	–	±0.1	±0.3	%FSS
Long-term stability of offset and span <sup>(5)</sup>	–	±0.1	±0.3	%FSS
Response time <sup>(6)</sup>	–	±0.1	–	ms
Input resistance	4.00	4.75	6.0	kΩ
Output resistance	4.00	4.75	6.0	kΩ

# 19 mm Series

## Notes:

1. Reference conditions (unless otherwise noted): TA = 25 °C [77 °F]; 19C Supply VS = 10 Vdc ±0.01 Vdc or IS = 1.5 mA ±0.0015 mA; 19U Supply VS = 5 Vdc ±0.01 Vdc or I = 1.0 mA ±0.0015 mA.
2. Full-scale span (FSS) is the algebraic difference between the output voltage at full-scale pressure and the output at zero pressure. FSS is ratiometric to supply voltage.
3. Pressure non-linearity is based on best-fit straight line from zero to the full-scale pressure. Pressure hysteresis is the maximum output difference at any point within the operation pressure range for increasing and decreasing pressure.
4. Maximum error band of the offset voltage or span over the compensated temperature range, relative to the 25 °C [77 °F] reading.
5. Long-term stability over a six-month period.
6. Response time for a 0 psi to FSS pressure step change, 10% to 90% rise time.
7. The maximum pressure that can be applied without changing the transducer's performance or accuracy.
8. The maximum pressure that can be applied to a transducer without rupture of either the sensing element or transducer.
9. Common mode voltage as measured from output to ground. For higher levels of common mode voltage, contact factory.
10. The error band resulting from a maximum deviation of a transducer's output parameter (offset, span, or resistance) as temperature is varied 25 °C [77 °F] to any other temperature within the specified range (0 °C to 82 °C [32 °F to 180 °F]). This parameter is not 100% tested and is guaranteed by process design and tested on a sample basis only. Temperature coefficient of span is evaluated using a 1 mA constant current excitation source.

## PHYSICAL DIMENSIONS (For reference only: mm [in].)

### Package 1 (see note): Cell Package



**Note:** Non-concentricity effects at the diaphragm weld area may cause runout of up to  $\pm 0.006$  in between the upper and lower portions of the sensor body. (It is recommended to use a counter bore to mate with this device to allow for this non-concentricity).

### Package 2: Flush Mount Package



### Package 3: Flush Mount with Flange

# Low Cost, Stainless Steel, Pressure Sensors



## Package 4: Male 1/8-27 NPT



## Package 5: Male 1/4-18 NPT



# 19 mm Series

## Package 6: Male 7/16 UNF



## Package 7: Male 1/4 BSPP



## Package 8: Euro Ring (See note)



**Note:** Non-concentricity effects at the diaphragm weld area may cause runout of up to  $\pm 0.006$  in between the upper and lower portions of the sensor body. (It is recommended to use a counter bore to mate with this device to allow for this non-concentricity).

# Low Cost, Stainless Steel, Pressure Sensors

## Package 9: VCR Gland (Female nut)

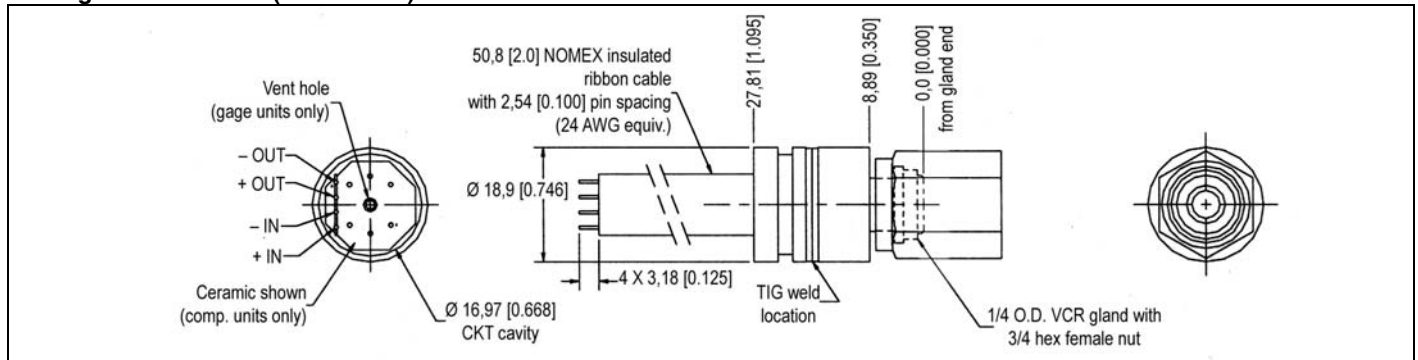

## ORDERING INFORMATION

### 19C Series



For example:  
Part #19C100PA4K =  
19 mm Cell,  
Compensated, 100 psi,  
Absolute, 1/8NPT Port  
with 10 Vdc excitation.

### 19U Series



For example:  
Part #19U100PA4K =  
19 mm Cell,  
Uncompensated, 100  
psi, Absolute, 1/8NPT  
Port with 5 Vdc  
excitation.

### 19 Vacuum Gauge Series



For example: Part  
#19C100PV4K = 19  
mm Cell, Comp., 100  
psi, Vacuum Gauge,  
1/8NPT Port with 10  
Vdc excitation.

For example: Part  
#19U100PV4K = 19  
mm Cell,  
Uncompensated, 100  
psi, Absolute, 1/8NPT  
Port with 5 Vdc  
excitation.

## **WARNING**

### **PERSONAL INJURY**

DO NOT USE these products as safety or emergency stop devices or in any other application where failure of the product could result in personal injury.

**Failure to comply with these instructions could result in death or serious injury.**

### **WARRANTY/REMEDY**

Honeywell warrants goods of its manufacture as being free of defective materials and faulty workmanship. Honeywell's standard product warranty applies unless agreed to otherwise by Honeywell in writing; please refer to your order acknowledgement or consult your local sales office for specific warranty details. If warranted goods are returned to Honeywell during the period of coverage, Honeywell will repair or replace, at its option, without charge those items it finds defective. **The foregoing is buyer's sole remedy and is in lieu of all other warranties, expressed or implied, including those of merchantability and fitness for a particular purpose. In no event shall Honeywell be liable for consequential, special, or indirect damages.**

While we provide application assistance personally, through our literature and the Honeywell web site, it is up to the customer to determine the suitability of the product in the application.

Specifications may change without notice. The information we supply is believed to be accurate and reliable as of this printing. However, we assume no responsibility for its use.

## **WARNING**

### **MISUSE OF DOCUMENTATION**

- The information presented in this product sheet is for reference only. Do not use this document as a product installation guide.
- Complete installation, operation, and maintenance information is provided in the instructions supplied with each product.

**Failure to comply with these instructions could result in death or serious injury.**

### **SALES AND SERVICE**

Honeywell serves its customers through a worldwide network of sales offices, representatives and distributors. For application assistance, current specifications, pricing or name of the nearest Authorized Distributor, contact your local sales office or:

**E-mail:** [info.sc@honeywell.com](mailto:info.sc@honeywell.com)

**Internet:** [www.honeywell.com/sensing](http://www.honeywell.com/sensing)

#### **Phone and Fax:**

Asia Pacific +65 6355-2828  
+65 6445-3033 Fax  
Europe +44 (0) 1698 481481  
+44 (0) 1698 481676 Fax  
Latin America +1-305-805-8188  
+1-305-883-8257 Fax  
USA/Canada +1-800-537-6945  
+1-815-235-6847  
+1-815-235-6545 Fax

Sensing and Control  
Honeywell  
1985 Douglas Drive North  
Minneapolis, MN 55422  
[www.honeywell.com/sensing](http://www.honeywell.com/sensing)

009132-3-EN IL50 GLO Printed in USA  
February 2008  
Copyright © 2008 Honeywell International Inc. All rights reserved.

# **Honeywell**



Компания «Океан Электроники» предлагает заключение долгосрочных отношений при поставках импортных электронных компонентов на взаимовыгодных условиях!

Наши преимущества:

- Поставка оригинальных импортных электронных компонентов напрямую с производств Америки, Европы и Азии, а так же с крупнейших складов мира;
- Широкая линейка поставок активных и пассивных импортных электронных компонентов (более 30 млн. наименований);
- Поставка сложных, дефицитных, либо снятых с производства позиций;
- Оперативные сроки поставки под заказ (от 5 рабочих дней);
- Экспресс доставка в любую точку России;
- Помощь Конструкторского Отдела и консультации квалифицированных инженеров;
- Техническая поддержка проекта, помощь в подборе аналогов, поставка прототипов;
- Поставка электронных компонентов под контролем ВП;
- Система менеджмента качества сертифицирована по Международному стандарту ISO 9001;
- При необходимости вся продукция военного и аэрокосмического назначения проходит испытания и сертификацию в лаборатории (по согласованию с заказчиком);
- Поставка специализированных компонентов военного и аэрокосмического уровня качества (Xilinx, Altera, Analog Devices, Intersil, Interpoint, Microsemi, Actel, Aeroflex, Peregrine, VPT, Syfer, Eurofarad, Texas Instruments, MS Kennedy, Miteq, Cobham, E2V, MA-COM, Hittite, Mini-Circuits, General Dynamics и др.);

Компания «Океан Электроники» является официальным дистрибьютором и эксклюзивным представителем в России одного из крупнейших производителей разъемов военного и аэрокосмического назначения «JONHON», а так же официальным дистрибьютором и эксклюзивным представителем в России производителя высокотехнологичных и надежных решений для передачи СВЧ сигналов «FORSTAR».



## JONHON

«JONHON» (основан в 1970 г.)

Разъемы специального, военного и аэрокосмического назначения:

(Применяются в военной, авиационной, аэрокосмической, морской, железнодорожной, горно- и нефтедобывающей отраслях промышленности)

«FORSTAR» (основан в 1998 г.)

ВЧ соединители, коаксиальные кабели, кабельные сборки и микроволновые компоненты:

(Применяются в телекоммуникациях гражданского и специального назначения, в средствах связи, РЛС, а так же военной, авиационной и аэрокосмической отраслях промышленности).



Телефон: 8 (812) 309-75-97 (многоканальный)

Факс: 8 (812) 320-03-32

Электронная почта: [ocean@oceanchips.ru](mailto:ocean@oceanchips.ru)

Web: <http://oceanchips.ru/>

Адрес: 198099, г. Санкт-Петербург, ул. Калинина, д. 2, корп. 4, лит. А