

DESCRIPTION

The MP3412 is a synchronous, fixed frequency, high efficiency step-up WLED driver with true output load disconnect function in a low profile 6-lead Thin-SOT23 package.

The MP3412 can startup from an input voltage as low as 0.8V and provides in-rush current limiting as well as output short circuit protection. The open load protection is also integrated

A switching frequency of 1MHz minimizes overall solution footprint by allowing the use of tiny, low profile inductors and ceramic capacitors. Current mode PWM control with internal compensation reduces external parts, thereby saving critical board space.

The device also features low shutdown current of under 1µA. The true output disconnect feature allows the output to be completely discharged in shutdown. It also limits the inrush of current during start-up, minimizing surge current seen by the input supply.

The MP3412 is available in 6-pin thin SOT23 package.

FEATURES

- Input Range: 0.8V to 4.4V
- Output Range: 2.5V to 5.0V
- 0.8V Low Start-Up Voltage
- Internal Power MOSFET and Synchronous Rectifier
- 1MHz Fixed Switching Frequency
- Current Mode Control with Internal Compensation
- Up to 96% Efficiency
- <1µA Shutdown Current
- Tiny External Components
- True Output Load Disconnect
- Inrush Current Limiting and Internal Soft-Start
- Open-Load Protection
- Short-Circuit Protection
- Available in TSOT23-6 Package

APPLICATION

- General LED Illuminations
- Cellular Phones
- Digital Cameras
- Handheld Instruments
- Wireless Handsets
- GPS Receivers

All MPS parts are lead-free, halogen free, and adhere to the RoHS directive. For MPS green status, please visit MPS website under Quality Assurance. "MPS" and "The Future of Analog IC Technology" are Registered Trademarks of Monolithic Power Systems, Inc.

TYPICAL APPLICATION

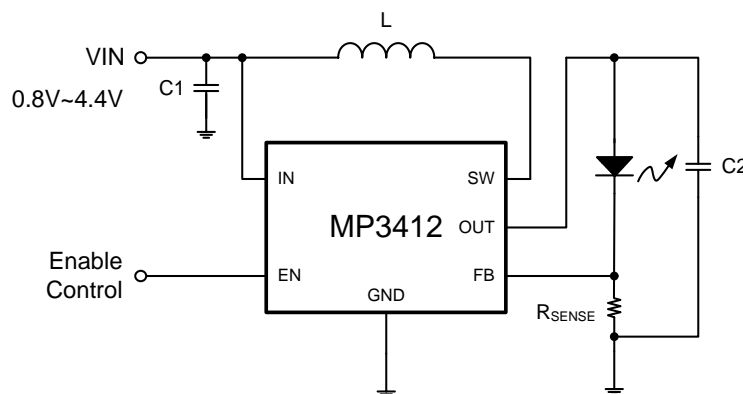

Efficiency

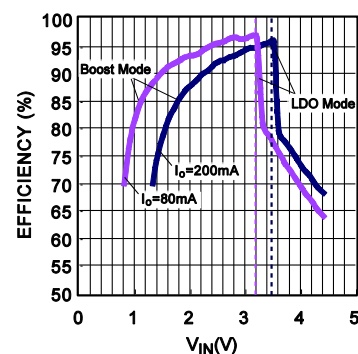

ORDERING INFORMATION

Part Number*	Package	Top Marking
MP3412EJ	TSOT23-6	See Below

* For Tape & Reel, add suffix -Z (e.g. MP3412EJ-Z).
 For RoHS Compliant Packaging, add suffix -LF (e.g. MP3412EJ-LF-Z)

TOP MARKING

| 7QYW

7Q: product code of MP3412EJ;
 Y: year code;
 W: week code:

PACKAGE REFERENCE

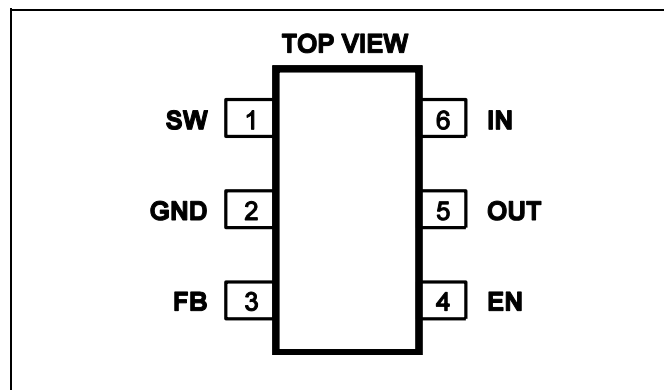

ABSOLUTE MAXIMUM RATINGS ⁽¹⁾

IN Pin.....	-0.3V to 4.6V
All other Pins	-0.3V to 6.5V
Continuous Power Dissipation (T _A = +25°C) ⁽²⁾	0.56W
Junction Temperature	150°C
Lead Temperature	260°C
Storage Temperature.....	-65°C to +150°C

Recommended Operating Conditions ⁽³⁾

Input Supply Voltage V _{IN}	0.8V to 4.4V
Output Voltage V _{OUT}	2.5V to 5.0V
Operating Junct. Temp. (T _J).....	-40°C to +125°C

Thermal Resistance ⁽⁴⁾	θ_{JA}	θ_{JC}
TSOT23-6.....	220	110 .. °C/W

Notes:

- 1) Exceeding these ratings may damage the device.
- 2) The maximum allowable power dissipation is a function of the maximum junction temperature T_J(MAX), the junction-to-ambient thermal resistance θ_{JA}, and the ambient temperature T_A. The maximum allowable continuous power dissipation at any ambient temperature is calculated by P_D(MAX)=(T_J(MAX)-T_A)/θ_{JA}. Exceeding the maximum allowable power dissipation will cause excessive die temperature, and the regulator will go into thermal shutdown. Internal thermal shutdown circuitry protects the device from permanent damage.
- 3) The device is not guaranteed to function outside of its operating conditions.
- 4) Measured on JESD51-7, 4-layer PCB.

ELECTRICAL CHARACTERISTICS

$V_{IN} = V_{EN} = 1.2V$, $I_{LED} = 200mA$, $T_A = +25^{\circ}C$, unless otherwise noted.

Parameters	Symbol	Condition	Min	Typ	Max	Units
Minimum Startup Voltage	V_{ST_MIN}	$V_{OUT} = 0V$	0.62	0.72	0.82	V
Maximum Input Voltage	V_{IN_MAX}				4.4	V
Output Voltage Range	V_{OUT}		2.5		5	V
Supply Current (Quiescent)	I_O	$V_{EN} = V_{IN} = 1.2V$, $V_{FB} = 0.3V$, Measured on OUT pin		380	600	μA
Supply Current (Shutdown)	I_{SD}	$V_{EN} = V_{OUT} = 0V$, $V_{IN} = 3.3V$ Measured on IN pin			1	μA
Operation Frequency	f_{SW}		0.90	1.05	1.20	MHz
Maximum Duty Cycle	D_{MAX}		87			%
Feedback Voltage	V_{FB}		190	200	210	mV
EN Low Threshold	V_{EN_LOW}	V_{EN} Falling	0.4			V
EN High Threshold	V_{EN_HIGH}	V_{EN} Rising			0.62	V
EN Input Current	I_{EN}	$V_{EN} = 6V$		16		nA
		$V_{EN} = 0V$		0		nA
NMOS On Resistance ⁽⁵⁾	R_{NMOS_ON}			336		m Ω
Synchronous Switch On Resistance ⁽⁵⁾	R_{PMOS_ON}			405		m Ω
NMOS Current Limit ⁽⁵⁾	I_{LIMIT}	$V_{OUT} = 2V$, Start-up period		0.5		A
		$V_{OUT} = 3.3V$		1.1		A
Over Voltage Protection Threshold	V_{OVP}	V_{SW} Rising	4.8	5.1	5.5	V
Soft-Start Time	T_{SS}	Open loop		200		μs
Thermal Shutdown ⁽⁵⁾				150		$^{\circ}C$

Notes:

5) Guaranteed by design.

PIN FUNCTIONS

Pin #	Name	Pin Function
1	SW	Power Switch Output. SW is the connection node of the internal NMOS switch and synchronous switch. Connect the power inductor to SW.
2	GND	Ground.
3	FB	Feedback Input to the Error Amplifier. Connect the anode of LED to this pin. The feedback reference voltage is 0.2V
4	EN	Enable Control Input.
5	OUT	Step-up Converter Output. OUT is the drain of the Internal Synchronous Rectifier MOSFET. Connect the LED anode to this pin. OUT pin is completely disconnected from IN pin when EN is low due to the output disconnect feature.
6	IN	Battery Supply Input. Must be locally bypassed

TYPICAL PERFORMANCE CHARACTERISTICS

$V_{IN} = V_{EN} = 1.8V$, $I_{LED} = 200mA$, One WLED, unless otherwise noted.

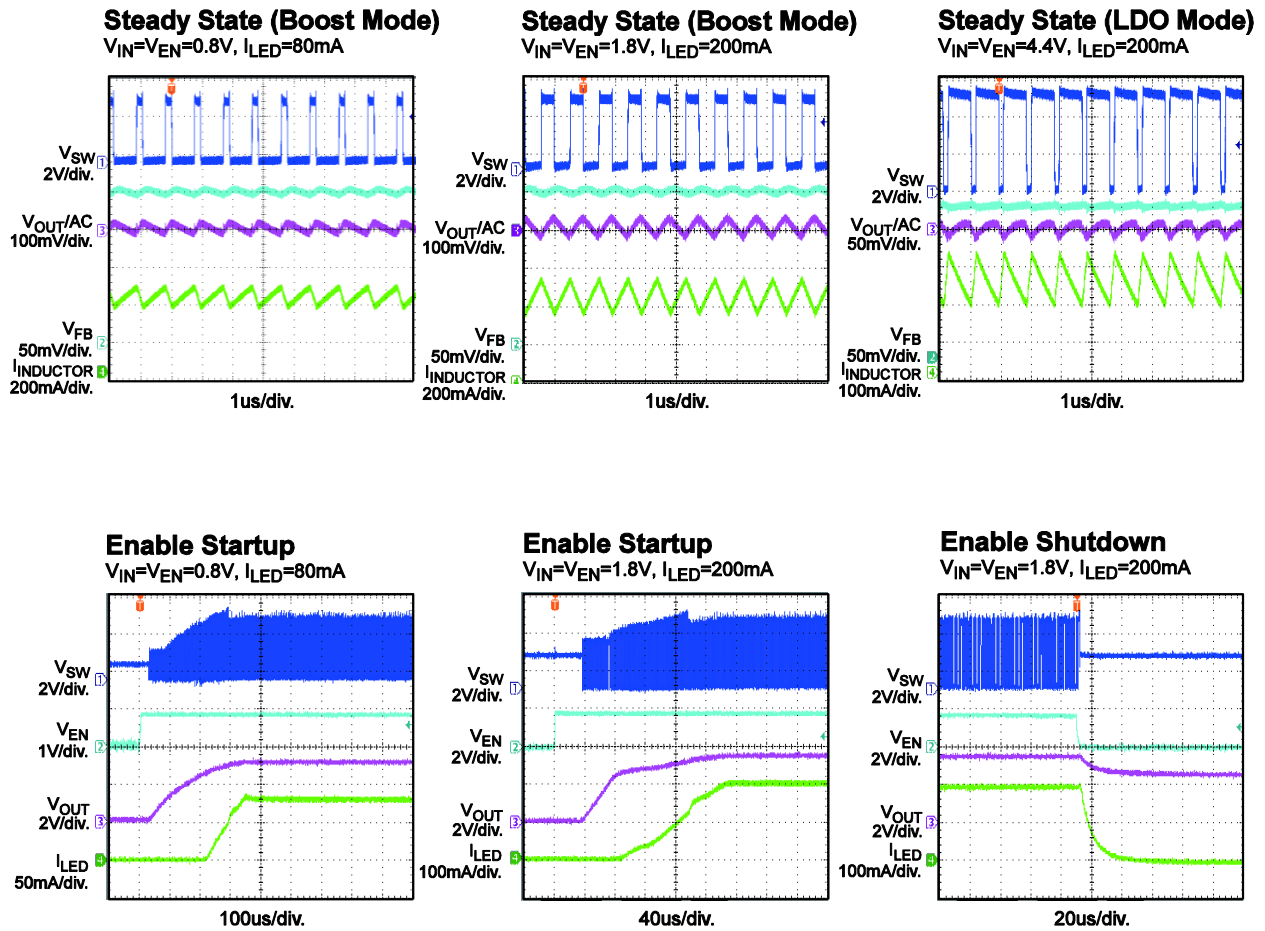
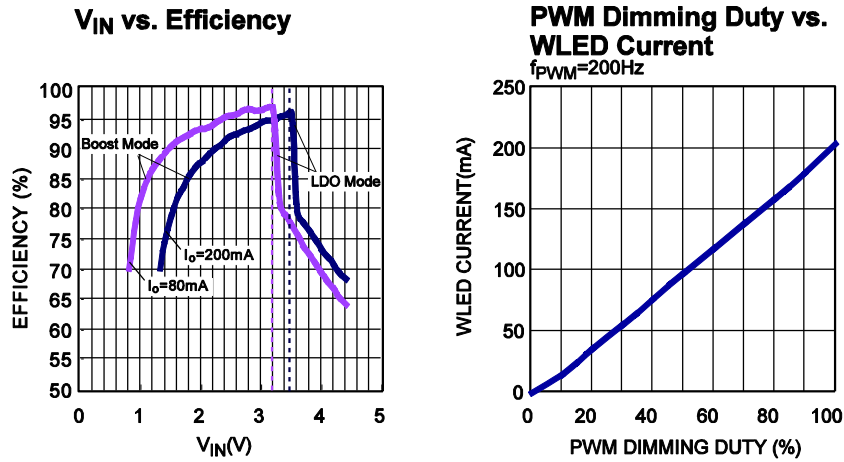

TYPICAL PERFORMANCE CHARACTERISTICS (continued)

$V_{IN} = V_{EN} = 1.8V$, $I_{LED} = 200mA$, One WLED, unless otherwise noted.

PWM Dimming
 $f_{PWM}=200Hz$, DPWM=50%

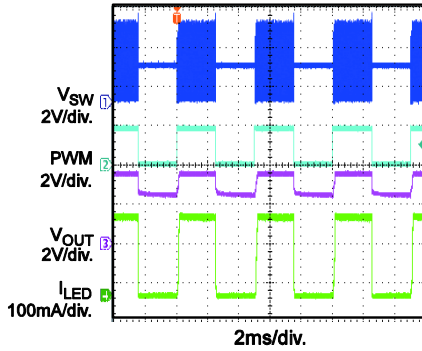

Open Load Protection
 Remove LED at working

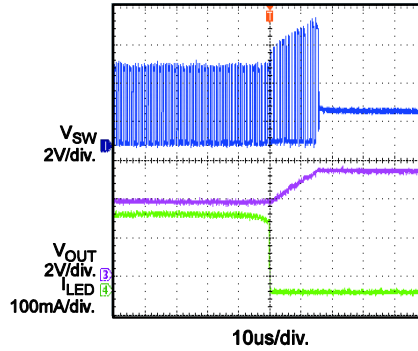

Short LED Protection
 Short start up then recover

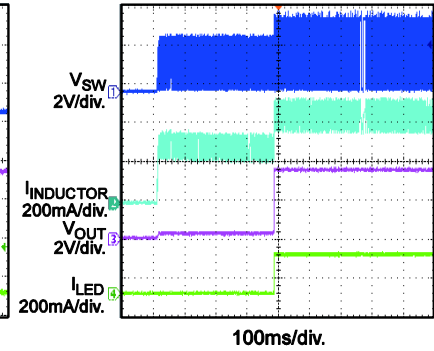

Short LED Protection
 Short at working then recover

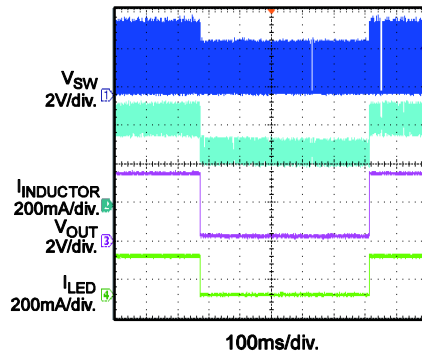

Short OUT to GND Protection
 Short start up then recover

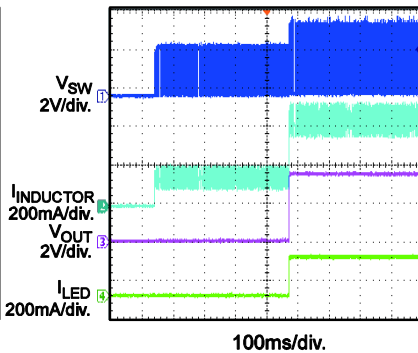

Short OUT to GND Protection
 Short at working then recover

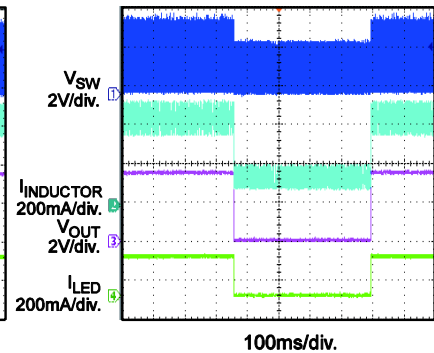

FUNCTION BLOCK DIAGRAM

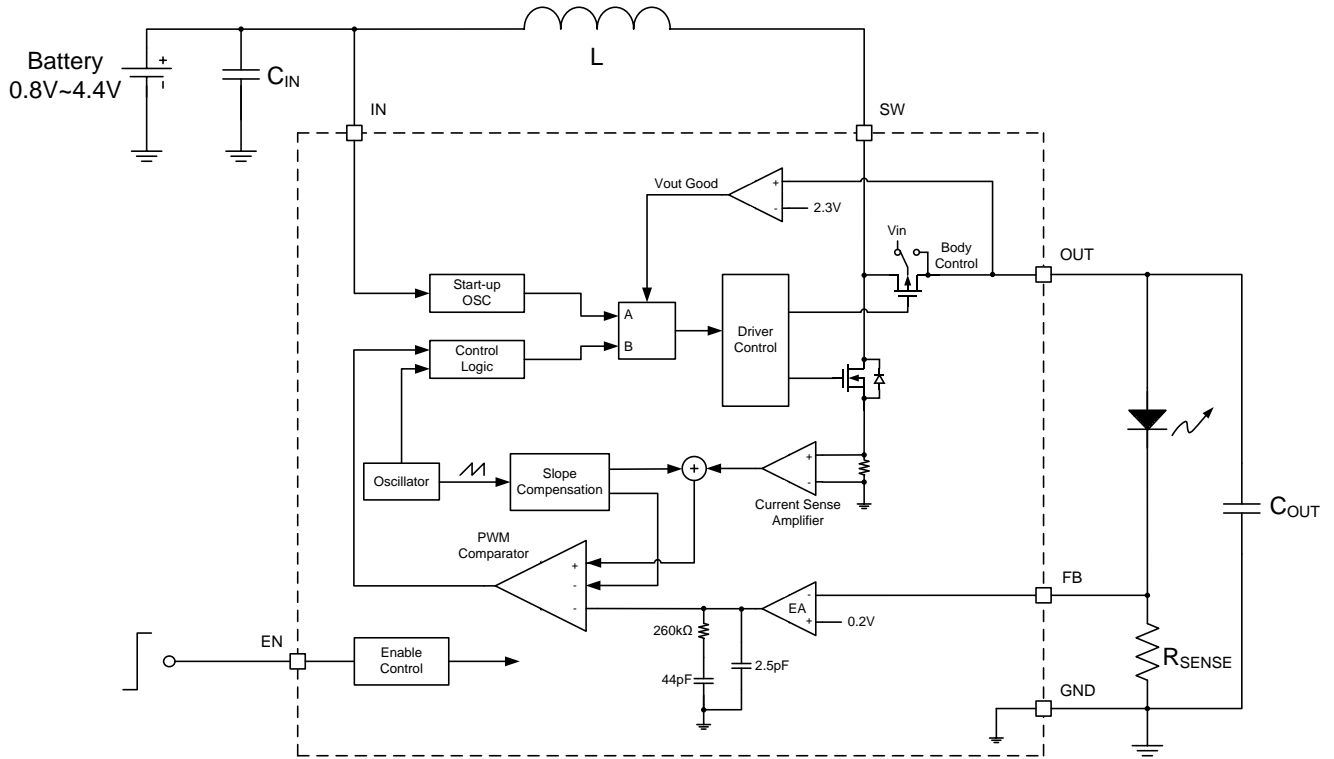

OPERATION

The MP3412 is a 1MHz, synchronous boost WLED driver in a 6-lead TSOT-23 package. It is able to operate from an input voltage below 1V. Fixed frequency PWM current mode control is applied to regulate the WLED current. Low $R_{DS(ON)}$ internal MOSFET switches enable the device to maintain high efficiency over a wide range of WLED current.

Low Voltage Start-Up

The MP3412 includes an independent start-up oscillator designed to start up at input voltages of 0.8V typically. The frequency and duty cycle of the start-up oscillator are internally set to 250kHz and 70% respectively. In this mode, the IC operates completely open-loop and the current limit is also set internally to 1.1A. Once the output voltage exceeds 2.3V, the start-up circuitry is disabled and normal close-loop PWM operation is initiated. In this mode, the MP3412 is biased by V_{OUT} instead of V_{IN} . This feature makes the chip can work normally when V_{IN} drops to 0.5V. Soft-start and inrush current limiting are provided during start-up process.

Soft-Start

The MP3412 realizes soft-start by charging an internal capacitor with a current source. The voltage on this capacitor slowly ramps the peak inductor current from 300mA to 1.1A. The soft-start time is typically 200 μ s. But this time varies greatly with load current, output voltage and input voltage. The soft-start capacitor is discharged completely when the chip is shut down, and discharged partially when the output is short circuit.

Oscillator

The frequency of operation is internally set to 1MHz.

Error Amp

The error amplifier is an internally compensated transconductance type amplifier. Its transconductance is about 33 microsiemens. The current sensing resistor R_{SENSE} feeds back the WLED current signal to FB pin. And the voltage at the FB is compared to the internal 200mV reference voltage to generate an error signal at the output of error amplifier.

Switch Current Sensing

Lossless current sensor converts the NMOS switch current signal to a voltage signal, and sum with the internal slope compensation signal. The summed signal is compared with the error amplifier output to generate a PWM signal to control the switch. The switch peak current is limited to 1.1A independent of input or output voltage. The switch current signal is blanked for 60ns after the switch is on to enhance noise rejection.

Synchronous Rectifier

The PMOS synchronous rectifier is enabled when $V_{OUT} > (V_{IN} + 0.1V)$ and the FB pin is $> 130mV$.

Thermal Shutdown

An internal temperature monitor will start to reduce the peak current limit if the die temperature exceeds 125°C. And if the die temperature continues to rise and reaches 150°C, the part will be thermal shutdown. All switches would be off and the soft-start capacitor would be discharged completely. The chip will be enabled again if the die temperature drops down.

Output Disconnect and Inrush Limiting

The MP3412 is designed to allow true output disconnect by eliminating body diode conduction of the internal PMOS rectifier. This makes V_{OUT} to decrease to zero volts during shutdown. This feature is also convenient to limit the inrush current during start up.

$V_{OUT} < V_{IN}$ Operation

The MP3412 will maintain current regulation even if the input voltage is above the output voltage. Since the PMOS no longer acts as a low impedance switch in this mode, there will be more power dissipation in IC, and the efficiency in this mode is low. The maximum output current should be limited in order to maintain an acceptable junction temperature.

Open Load Protection

Open load protection will shut down the MP3412. If the WLED is fail, the feedback voltage will always be zero, and the part will run at maximum duty cycle. The output voltage will be boosted very high. When the output voltage of SW exceeds 5.1V, the MP3412 will be shut down. And it does not switch again until the power is recycled.

Short Circuit Protection

Unlike most boost converters, the MP3412 allows their output to be short circuit due to the output disconnect feature. The device incorporates internal features such as current limit function, thermal regulation and thermal shutdown to protect the chip from burn out which is caused by an excessive overload or short circuit. In the event of a short circuit, the internal soft-start capacitor gets partially discharged. This, in turn, decreased the current limit threshold from 1.1A to a small value. In addition to this, a thermal regulation circuit starts to work to decrease the current limit farther if the die temperature rises above 125°C. And if the die temperature still rises and reaches 150°C, the chip will be shut down.

APPLICATION INFORMATION

Setting the LED Current

The regulated LED current is identical and set through the current sensing resistor through the use of the equation:

$$I_{LED} = 0.2V / R_{SENSE}$$

For $R_{SENSE}=1\Omega$, the LED current is set to about 200mA.

PWM Dimming

Apply a typical 200Hz square waveform to the EN pin to implement PWM dimming of the LEDs. The minimum recommended amplitude of the PWM signal is 0.8V.

Selecting the Inductor

A 3.3 μ H to 10 μ H inductor with a DC current rating of at least 40% higher than the maximum input current is recommended for most applications at wide input range. For highest efficiency, the inductor's DC resistance should be as small as possible.

Selecting the Input Capacitor

The input capacitor reduces the surge current drawn from the input supply and the switching noise from the device. The input capacitor impedance at the switching frequency should be less than the input source impedance to prevent high frequency switching current from passing through the input. Ceramic capacitors with X5R or X7R dielectrics are highly recommended because of their low ESR and small temperature coefficients. For most applications, a 4.7 μ F or 10 μ F capacitor is sufficient.

Selecting the Output Capacitor

The output capacitor keeps the output voltage ripple small and ensures feedback loop stability. The output capacitor impedance should be low at the switching frequency. Ceramic capacitors with X7R dielectrics are recommended for their low ESR characteristics. For most applications, a 2.2 μ F ceramic capacitor is sufficient.

Layout Considerations

Careful attention must be paid to the PCB board layout and components placement. Proper layout of the high frequency switching path is critical to prevent noise and electromagnetic interference problems. The loop of MP3412 SW to GND pin, SW to OUT pin, and output capacitor is flowing with high frequency pulse current. It must be as short as possible. The IN and OUT pin are both the power supply input for the internal MOSFET switch gate driver and the internal control circuitry. They must be locally bypassed.

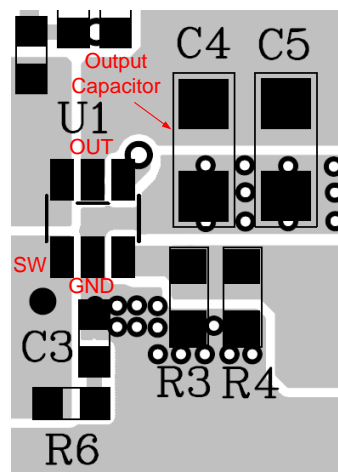

Figure 1- Layout Consideration

TYPICAL APPLICATION CIRCUIT

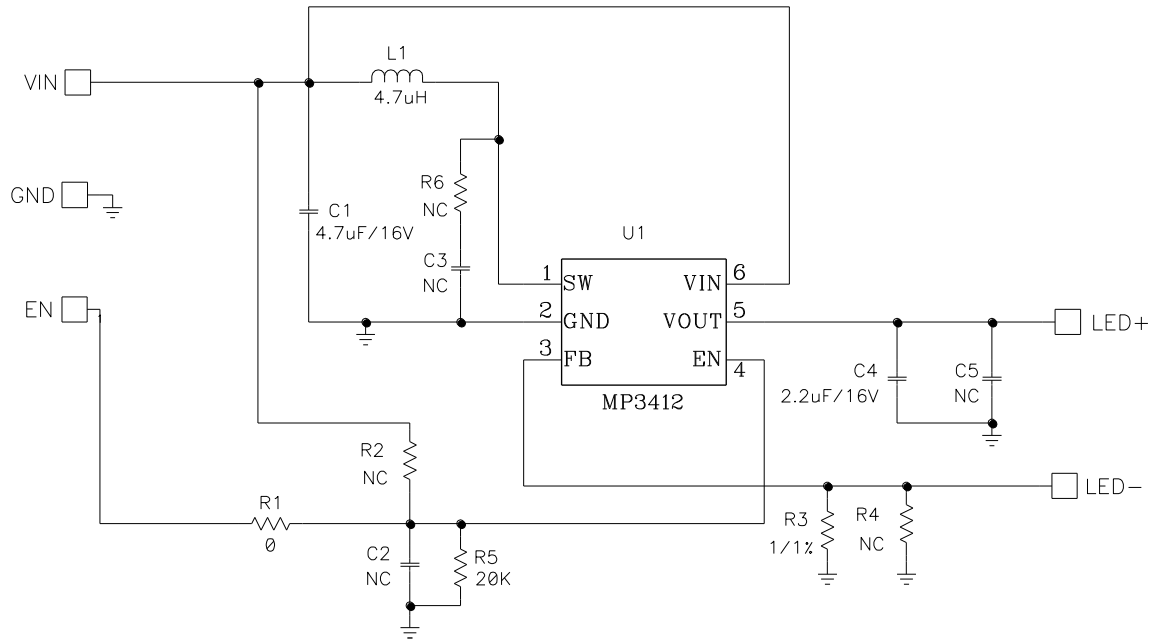
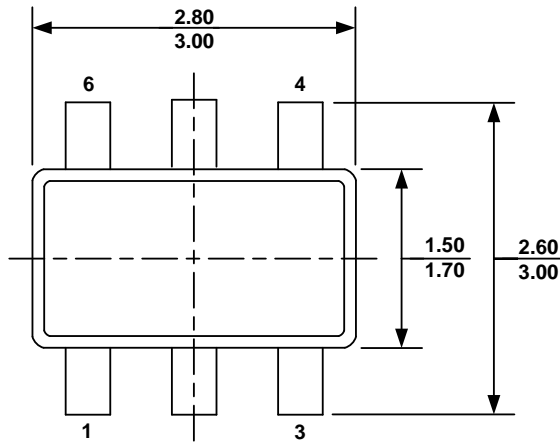

Figure 2—Step-up White LED Driver Application

PACKAGE INFORMATION

TSOT23-6



TOP VIEW

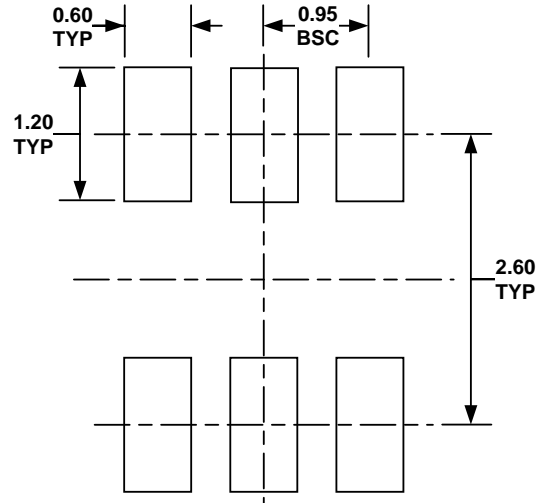

RECOMMENDED LAND PATTERN

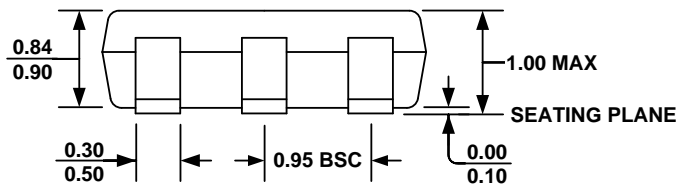

FRONT VIEW

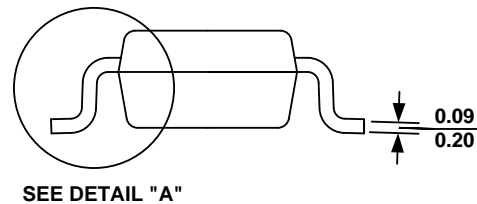

SIDE VIEW

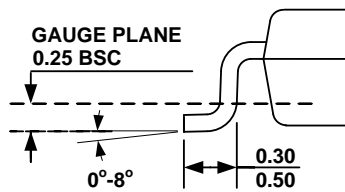

DETAIL "A"

NOTE:

- 1) ALL DIMENSIONS ARE IN MILLIMETERS.
- 2) PACKAGE LENGTH DOES NOT INCLUDE MOLD FLASH, PROTRUSION OR GATE BURR.
- 3) PACKAGE WIDTH DOES NOT INCLUDE INTERLEAD FLASH OR PROTRUSION.
- 4) LEAD COPLANARITY (BOTTOM OF LEADS AFTER FORMING) SHALL BE 0.10 MILLIMETERS MAX.
- 5) DRAWING CONFORMS TO JEDEC MO-193, VARIATION AA.
- 6) DRAWING IS NOT TO SCALE.

NOTICE: The information in this document is subject to change without notice. Users should warrant and guarantee that third party Intellectual Property rights are not infringed upon when integrating MPS products into any application. MPS will not assume any legal responsibility for any said applications.

Компания «Океан Электроники» предлагает заключение долгосрочных отношений при поставках импортных электронных компонентов на взаимовыгодных условиях!

Наши преимущества:

- Поставка оригинальных импортных электронных компонентов напрямую с производств Америки, Европы и Азии, а так же с крупнейших складов мира;
- Широкая линейка поставок активных и пассивных импортных электронных компонентов (более 30 млн. наименований);
- Поставка сложных, дефицитных, либо снятых с производства позиций;
- Оперативные сроки поставки под заказ (от 5 рабочих дней);
- Экспресс доставка в любую точку России;
- Помощь Конструкторского Отдела и консультации квалифицированных инженеров;
- Техническая поддержка проекта, помощь в подборе аналогов, поставка прототипов;
- Поставка электронных компонентов под контролем ВП;
- Система менеджмента качества сертифицирована по Международному стандарту ISO 9001;
- При необходимости вся продукция военного и аэрокосмического назначения проходит испытания и сертификацию в лаборатории (по согласованию с заказчиком);
- Поставка специализированных компонентов военного и аэрокосмического уровня качества (Xilinx, Altera, Analog Devices, Intersil, Interpoint, Microsemi, Actel, Aeroflex, Peregrine, VPT, Syfer, Eurofarad, Texas Instruments, MS Kennedy, Miteq, Cobham, E2V, MA-COM, Hittite, Mini-Circuits, General Dynamics и др.);

Компания «Океан Электроники» является официальным дистрибьютором и эксклюзивным представителем в России одного из крупнейших производителей разъемов военного и аэрокосмического назначения «JONHON», а так же официальным дистрибьютором и эксклюзивным представителем в России производителя высокотехнологичных и надежных решений для передачи СВЧ сигналов «FORSTAR».



JONHON

«JONHON» (основан в 1970 г.)

Разъемы специального, военного и аэрокосмического назначения:

(Применяются в военной, авиационной, аэрокосмической, морской, железнодорожной, горно- и нефтедобывающей отраслях промышленности)

«FORSTAR» (основан в 1998 г.)

ВЧ соединители, коаксиальные кабели, кабельные сборки и микроволновые компоненты:

(Применяются в телекоммуникациях гражданского и специального назначения, в средствах связи, РЛС, а так же военной, авиационной и аэрокосмической отраслях промышленности).



Телефон: 8 (812) 309-75-97 (многоканальный)

Факс: 8 (812) 320-03-32

Электронная почта: ocean@oceanchips.ru

Web: <http://oceanchips.ru/>

Адрес: 198099, г. Санкт-Петербург, ул. Калинина, д. 2, корп. 4, лит. А