

MAX15090B/MAX15090C Evaluation Kits

Evaluate: MAX15090B/MAX15090C

General Description

The MAX15090B/MAX15090C evaluation kits (EV kit) provide a proven design to evaluate the MAX15090B/MAX15090C hot-swap controllers with an integrated 12A MOSFET. The EV kit is configured to pass 12A in a 2.7V to 18V hot-swap application, thus providing a fully integrated solution. The EV kit uses the MAX15090BEWI+/MAX15090CEWI+ in a 3.5mm x 2mm, 28-bump, 0.5mm pitch wafer-level package (WLP) with a proven four-layer PCB design. As configured, the EV kit is optimized to operate at 12V.

Ordering Information appears at end of data sheet.

Component List

| DESIGNATION | QTY | DESCRIPTION |
|-------------|-----|--|
| C1, C2 | 2 | 1 μ F \pm 10%, 25V X7R ceramic capacitors (0603) Murata GRM188R71E105K TDK C1608X5R1E105M |
| C3 | 1 | 5600pF \pm 10%, 50V X7R ceramic capacitor (0603) Murata GRM188R71H562K TDK C1608C0G1H562J |
| C4 | 1 | 0.047 μ F \pm 10%, 25V X7R ceramic capacitor (0603) Murata GRM188R71E473K TDK C1608X7R1E473K |
| C5 | 1 | 0.22 μ F \pm 10%, 25V X7R ceramic capacitor (0603) Murata GRM188R71E224K TDK C1608X7R1E224K |
| C6–C11 | 6 | 10 μ F \pm 10%, 25V X7R ceramic capacitors (1206) Murata GRM31CR71E106K TDK C3216X5R1E106M |
| C12 | 0 | Not installed, ceramic capacitor (1206) |
| C13 | 0 | Not installed, electrolytic capacitor (D = 11mm) |

Features

- 2.7V to 18V Operating Voltage Range
- Up to 12A Configurable Load Current Capability
- Banana Jacks for Input and Output Voltage
- Programmable Slew-Rate Control
- Selectable/Configurable Circuit-Breaker Threshold
- Configurable Overvoltage/Undervoltage Lockout
- Programmable Timeout Delay
- $\overline{\text{FAULT}}$ and PG Outputs
- Defined Safe Operation Area
- Proven PCB Layout
- Fully Assembled and Tested

| DESIGNATION | QTY | DESCRIPTION |
|--------------------------------|-----|---|
| C14 | 0 | Not installed, ceramic capacitor (0805) |
| CDLY, GATE, GDRV, REG, UV, VCC | 6 | Red test points |
| D1 | 1 | 18V, 600W transient voltage suppressor (SMB) Fairchild SMBJ18A |
| D2 | 0 | Not installed, Schottky diode (SMA) |
| D3 | 0 | Not installed, Schottky diode (SOD523) |
| GND (x2), IN, OUT | 4 | Banana jacks |
| JU1 | 1 | 3-pin header |
| JU2 | 1 | 2-pin header |
| Q1 | 1 | 30V, 58A, 9m Ω n-channel MOSFET (DPAK) IRF FDD8880 |
| R1 | 1 | 178k Ω \pm 1% resistor (0603) |
| R2 | 1 | 5.23k Ω \pm 1% resistor (0603) |
| R3 | 1 | 17.8k Ω \pm 1% resistor (0603) |
| R4 | 1 | 10 Ω \pm 5% resistor (0603) |
| R5 | 1 | 40.2k Ω \pm 5% resistor (0603) |
| R6 | 1 | 787 Ω \pm 1% resistor (0603) |

MAX15090B/MAX15090C Evaluation Kits

Evaluate: MAX15090B/MAX15090C

Component List (continued)

| DESIGNATION | QTY | DESCRIPTION |
|-------------|-----|---|
| R7–R9 | 3 | 100kΩ ±5% resistors (0603) |
| R10 | 1 | 49.9Ω ±1% resistor (0603) |
| R11 | 1 | 50kΩ potentiometer |
| R12 | 1 | 0Ω resistor (0603) |
| U1 | 1 | 12A hot-swap solution (28 WLP) Maxim MAX15090BEWI+ or Maxim MAX15090CEWI+ |

| DESIGNATION | QTY | DESCRIPTION |
|-------------|-----|--|
| U2 | 1 | General-purpose timer (8 SO) Maxim ICM7555ISA |
| — | 2 | Shunts |
| — | 1 | PCB: MAX15090B EVALUATION KIT |

Component Suppliers

| SUPPLIER | PHONE | WEBSITE |
|-------------------------|--------------|------------------------|
| Fairchild Semiconductor | 888-522-5372 | www.fairchildsemi.com |
| Murata Americas | 770-436-1300 | www.murataamericas.com |
| TDK Corp. | 847-803-6100 | www.component.tdk.com |

Note: Indicate that you are using the MAX15090B/MAX15090C when contacting these component suppliers.

Quick Start

Required Equipment

- MAX15090B or MAX15090C EV kit
- 12V, 12A DC power supply
- Voltmeter

Procedure

The EV kit is fully assembled and tested. Follow the steps below to verify board operation. **Caution: Do not turn on the power supply until all connections are completed.**

- 1) Verify that a shunt is installed across pins 1-2 on jumper JU1.
- 2) Turn on the power supply and set the supply to 12V, then disable the power supply.
- 3) Connect the positive terminal of the power supply to the IN banana jack on the EV kit. Connect the negative terminal of the power supply to the GND banana jack.
- 4) Enable the power supply.
- 5) Verify that the voltage between the OUT and GND banana jacks is 12V.
- 6) Verify that the internal regulator voltage (REG) is 3.3V.
- 7) The EV kit is now ready for additional evaluation.

Detailed Description of Hardware

The MAX15090B EV kit provides a proven design to evaluate the MAX15090B. The MAX15090B EV kit can be conveniently connected between the system power and the load using the banana jacks provided for the input and

output. PCB pads are provided to monitor and control the device signals. The MAX15090B EV kit operates between 2.7V and 18V up to 12A load current capability.

Evaluating the MAX15090C

The MAX15090C EV kit can be used to evaluate the MAX15090C, with the MAX15090CEWI+ installed. The MAX15090C is pin-to-pin compatible with the MAX15090B. Refer to the MAX15090B/MAX15090C IC data sheet for details on the MAX15090C.

Circuit Breaker (CB)

Jumper JU1 sets the current limit for the internal circuit breaker (CB) of the device. The CB pin can be connected to a fixed resistor (R5) or a potentiometer (R11) to set the current limit. See [Table 1](#) for shunt positions.

The circuit-breaker threshold can be set according to the following formula:

$$I_{CB} = R_{CB}/3333.3$$

where I_{CB} is in A and R_{CB} (the resistor between CB and ground) is in Ω.

Table 1. JU1 Jumper Selection (CB)

| SHUNT POSITION | CB PIN CONNECTED TO | CURRENT LIMIT |
|----------------|---------------------|---------------|
| 1-2* | R5 | 12A |
| 2-3 | R11 | Adjustable |

*Default position.

Table 2. JU2 Jumper Selection (\overline{EN})

| SHUNT POSITION | \overline{EN} PIN | TIMEOUT DELAY |
|----------------|---|------------------|
| Installed | Forced to GND | Bypassed |
| Not installed* | Set low when C5 is charged to 2/3 x OUT; timing is set by R7/C5 | 47ms (set by C4) |

*Default position.

Setting Timeout Delay for \overline{EN} (CDLY)

Capacitor C4 is used to set the timeout delay for \overline{EN} to go low to prevent internal MOSFET shutdown after power-up. This is set at a rate of 1s/ μ F. The EV kit is configured for a 47ms timeout delay.

Delayed \overline{EN}

The IC's \overline{EN} pin must be pulled low before the timeout delay set by capacitor C4 elapses. The EV kit provides a simple timer circuit comprised of U2, R7, and C5 to pull the \overline{EN} pin low before the timeout delay. Once PG asserts as open-drain, R7 begins to charge C5 to the output voltage (OUT). When C5 charges to 2/3 x OUT, U2 pulls the \overline{EN} pin low. The EV kit is configured to have \overline{EN} pulled low after ~22ms.

Jumper JU2 is also provided to bypass the timeout delay and force \overline{EN} low, if installed. See [Table 2](#) for JU2 settings.

Setting the Output Slew Rate

An external capacitor (C3) is connected from GATE to GND on the IC to reduce the output slew rate during startup. During startup, a 5.7 μ A (typ) current is sourced to enhance the internal MOSFET with 10V/ms (typ). C3 can be calculated according to the following formula:

$$C3 = (I_{GATE} \times \Delta t) / \Delta V_{GATE}$$

where I_{GATE} is 5.7 μ A (typ), Δt is the desired slew rate, and ΔV_{GATE} is the voltage at the gate of the internal MOSFET at turn-on.

Undervoltage Lockout

The EV kit provides an option to configure the undervoltage-lockout threshold. The undervoltage-lockout threshold for the device is configured by the IN voltage level divided by R1 and (R2 + R3) at the UV pin. By default, the undervoltage-lockout threshold is set to 10.8V.

Overvoltage Lockout

The EV kit provides an option to configure the overvoltage-lockout threshold. The overvoltage-lockout threshold for the device is configured by the IN voltage level divided by (R1 + R2) and R3 at the OV pin. By default, the overvoltage-lockout threshold is set to 13.2V.

Current-Sense Output (ISENSE)

The IC's ISENSE pin is the output of an accurate current-sense amplifier and provides a source current proportional to the load current flowing into the main switch. The factory-trimmed current ratio is set to 220 μ A/A. On the EV kit, this allows producing a scaled voltage by routing resistor R6 from ISENSE to GND.

MAX15090B/MAX15090C Evaluation Kits

Evaluate: MAX15090B/MAX15090C

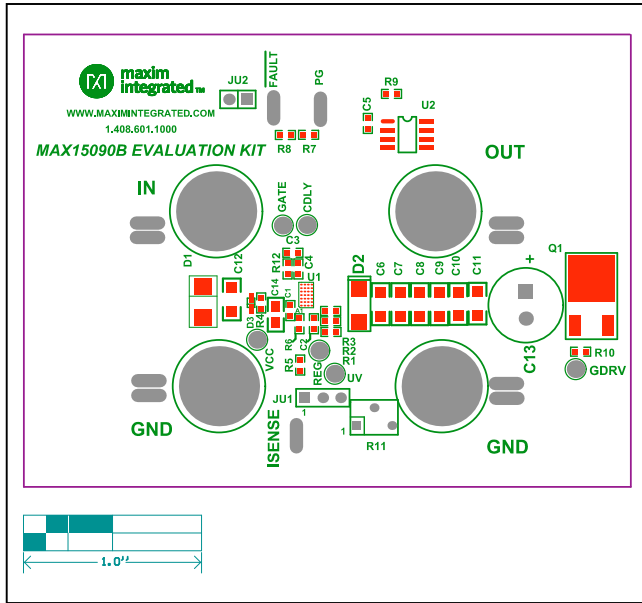

Figure 2. MAX15090B EV Kit Component Placement Guide—Component Side

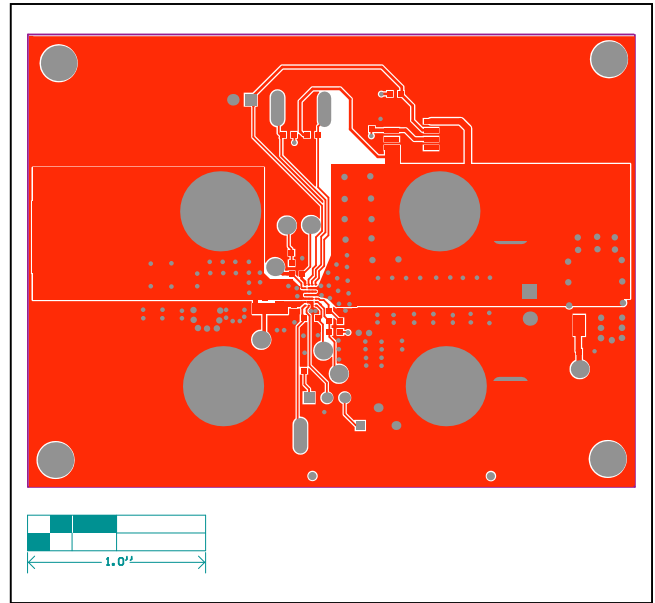

Figure 3. MAX15090B EV Kit PCB Layout—Component Side

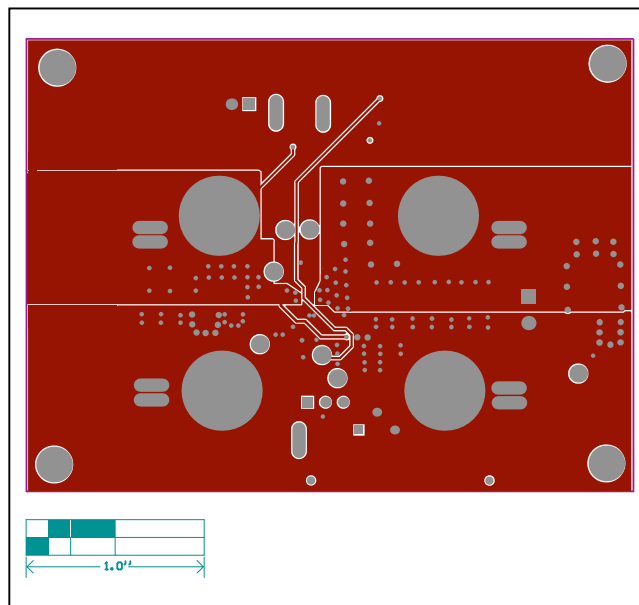

Figure 4. MAX15090B EV Kit PCB Layout—Layer 2 (PWR/GND)

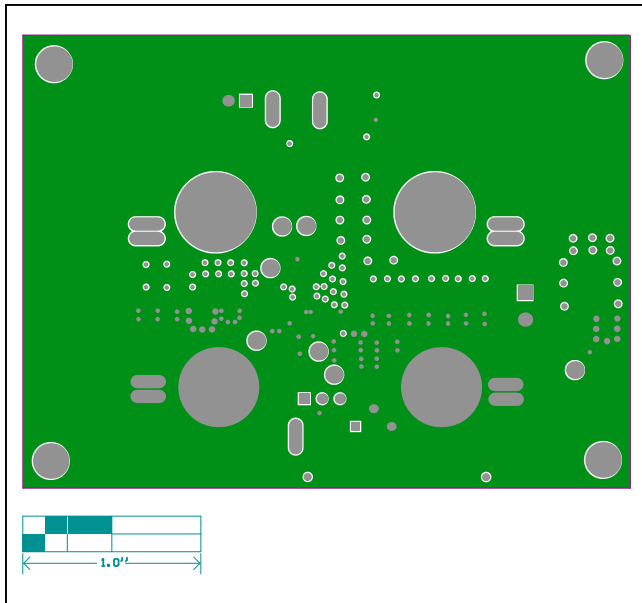

Figure 5. MAX15090B EV Kit PCB Layout—Layer 3 (GND)

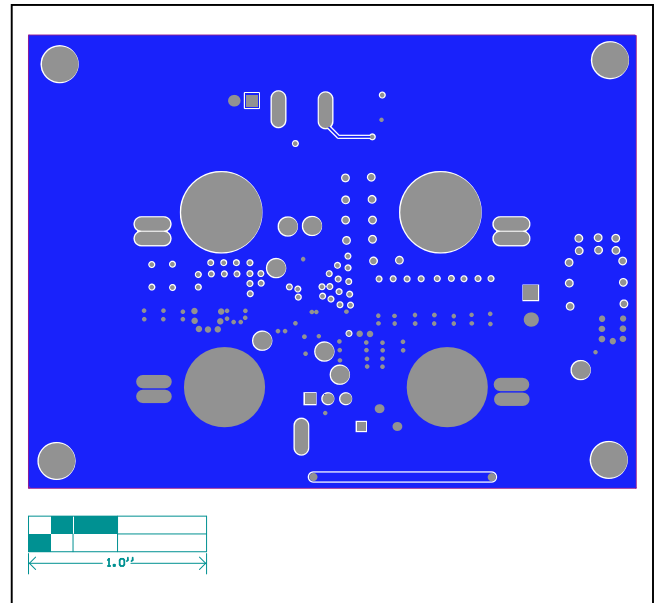

Figure 6. MAX15090B EV Kit PCB Layout—Solder Side

MAX15090B/MAX15090C
Evaluation Kits

Evaluate: MAX15090B/MAX15090C

Ordering Information

| PART | TYPE |
|-----------------|--------|
| MAX15090BEVKIT# | EV Kit |
| MAX15090CEVKIT# | EV Kit |

#Denotes RoHS compliant.

Revision History

| REVISION NUMBER | REVISION DATE | DESCRIPTION | PAGES CHANGED |
|-----------------|---------------|-----------------|---------------|
| 0 | 1/16 | Initial release | — |

For information on other Maxim Integrated products, visit Maxim Integrated's website at www.maximintegrated.com.

Maxim Integrated cannot assume responsibility for use of any circuitry other than circuitry entirely embodied in a Maxim Integrated product. No circuit patent licenses are implied. Maxim Integrated reserves the right to change the circuitry and specifications without notice at any time.

Компания «Океан Электроники» предлагает заключение долгосрочных отношений при поставках импортных электронных компонентов на взаимовыгодных условиях!

Наши преимущества:

- Поставка оригинальных импортных электронных компонентов напрямую с производств Америки, Европы и Азии, а так же с крупнейших складов мира;
- Широкая линейка поставок активных и пассивных импортных электронных компонентов (более 30 млн. наименований);
- Поставка сложных, дефицитных, либо снятых с производства позиций;
- Оперативные сроки поставки под заказ (от 5 рабочих дней);
- Экспресс доставка в любую точку России;
- Помощь Конструкторского Отдела и консультации квалифицированных инженеров;
- Техническая поддержка проекта, помощь в подборе аналогов, поставка прототипов;
- Поставка электронных компонентов под контролем ВП;
- Система менеджмента качества сертифицирована по Международному стандарту ISO 9001;
- При необходимости вся продукция военного и аэрокосмического назначения проходит испытания и сертификацию в лаборатории (по согласованию с заказчиком);
- Поставка специализированных компонентов военного и аэрокосмического уровня качества (Xilinx, Altera, Analog Devices, Intersil, Interpoint, Microsemi, Actel, Aeroflex, Peregrine, VPT, Syfer, Eurofarad, Texas Instruments, MS Kennedy, Miteq, Cobham, E2V, MA-COM, Hittite, Mini-Circuits, General Dynamics и др.);

Компания «Океан Электроники» является официальным дистрибьютором и эксклюзивным представителем в России одного из крупнейших производителей разъемов военного и аэрокосмического назначения «JONHON», а так же официальным дистрибьютором и эксклюзивным представителем в России производителя высокотехнологичных и надежных решений для передачи СВЧ сигналов «FORSTAR».



JONHON

«JONHON» (основан в 1970 г.)

Разъемы специального, военного и аэрокосмического назначения:

(Применяются в военной, авиационной, аэрокосмической, морской, железнодорожной, горно- и нефтедобывающей отраслях промышленности)

«FORSTAR» (основан в 1998 г.)

ВЧ соединители, коаксиальные кабели, кабельные сборки и микроволновые компоненты:

(Применяются в телекоммуникациях гражданского и специального назначения, в средствах связи, РЛС, а так же военной, авиационной и аэрокосмической отраслях промышленности).



Телефон: 8 (812) 309-75-97 (многоканальный)

Факс: 8 (812) 320-03-32

Электронная почта: ocean@oceanchips.ru

Web: <http://oceanchips.ru/>

Адрес: 198099, г. Санкт-Петербург, ул. Калинина, д. 2, корп. 4, лит. А