

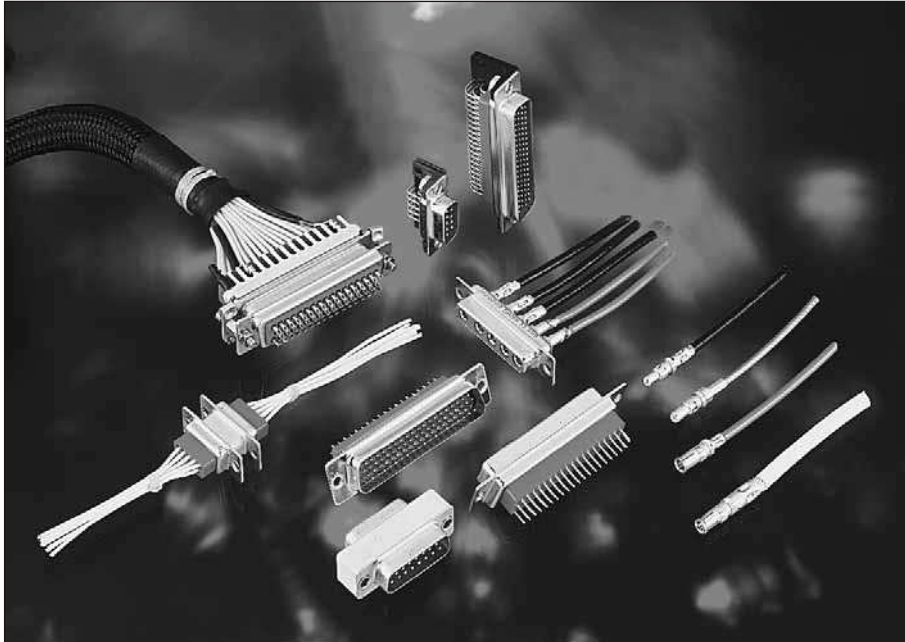

Connectors



Section

I

Non-magnetic D-Sub Connectors



Contents

• Non magnetic D-Sub Connectors

Cross reference table for ESA/SCC/SOURIAU/GSFC	7
Quality Assurance Testing	7
CHART V - Lot Acceptance Tests	8
Materials & Finishes	9
Electrical characteristics	9
Environmental characteristics	9

• D-Sub ESA/SCC 3401 001 01B

Part Number / Ordering Information	10
Contact termination code	10
Contact layouts	11
Contact types	11
Dimensions	12

• D-Sub ESA/SCC 3401 001 02B

Part Number / Ordering Information	14
Contact termination code	14
Contact layouts	15
Dimensions	15

• D-Sub ESA/SCC 3401 002 01B

Part Number / Ordering Information	17
Contact layouts (Male insulation front view)	17

• D-Sub ESA/SCC 3401 002 02B

Part Number / Ordering Information	18
Contact layouts (Male insulation front view)	18

• D-Sub Savers ESA/SCC 3401 020 01B & 3401 020 02B

Part Number / Ordering Information	19
--	----

• D-Sub D*M-NMB

Part Number / Ordering Information	20
Contact layouts	20
Contact termination code	21
Dimensions for termination code	21

• D-Sub 8630-NMB (Crimp)

Part Number / Ordering Information	23
Special modifier	23

• D-Sub 8635-NMB (Spill)

Part Number / Ordering Information	24
Contact termination type	24

• D-Sub 8635-NMB (Crimp)

Part Number / Ordering Information	25
Special modifier	25

• D-Sub Savers D*BMA-NMB

Part Number / Ordering Information	26
--	----

• Mounting option

Float Mounting (3401 001, 3401 002, D*MF, 8631 & 8635F)	27
Mounting with clinch nuts (O & L, D*M, 8630 & 8635)	27
Mounting with grommet (8630 & 8635)	27
Panel cut-outs	28
Panel mounting	28

• Printed circuit board drilling

Standard Density	29
High Density	30

• D-Sub Connectors - Physical dimensions

Male connectors	31
Female connectors	32
Saver connectors	33

• Crimp Contacts

Crimp Contacts	34
Insertion & Extraction tool	34
Removable contact identification	34
Savers contacts	34

• 3401 004/8949-004-NMB : Coaxial contacts

3401 004/8949-004 & 3401 040/8949-040 Contact identification	35
Part Numbers	35
Extraction tool	35
Dimensions	36

• 3401 040/8949-040-NMB : Power solder contacts

Part Numbers	37
Dimensions	37
Tooling of extraction	37

• 3401 040/8949-040-NMB : Power crimp contacts

Part Numbers	38
Dimensions	38
Extraction tool	38

• 3401 069 Twinax

Part Numbers	39
Dimensions	39
Wiring tool	39
Extraction tool	39

• Wiring instructions

Contact # 20	40
Contact # 22	40
Power contact # 8	40
PCB Contact	41
Stripping	42
Crimping	42
Crimp coaxial contacts	43
Solder coaxial contacts	43
Twinax contacts	44

• Accessories D-Sub ESA/SCC 3401 022 & Space grade

Male screw lock	46
Female screw lock	47
Dust cap	48

• Non magnetic D-Sub backshells ESA/SCC 3401 072 & Space grade

Lightweight design with saddle clamps for strain relief -	
Lightweight D-Sub shorting can	49
EMI shielded backshell-straight cable outlet	50
Light shielded backshell-90° longitudinal cable outlet	50
Lightweight shielded backshell-straight cable outlet	51
Lightweight backshell dual entry, 15 pin	51
Castellated backshell	51
Straight and 45° lightweight backshell ultra elliptical band-termination	52
Lightweight D-Sub extra-shortening can - Castellated backshell (new design)	53
Lightweight shielded backshells-45° & 90° longitudinal cable outlets	54
EMI/RFI shielded backshells. Straight & Low profile outlet	
banded clamp termination	55



Connectors

Applications

Satellite
 Launcher
 Space station
 Shuttle hardware
 Probe

Standards

ESA/SCC 3401/GSFC/MIL-DTL-24308
 class M (QPL)

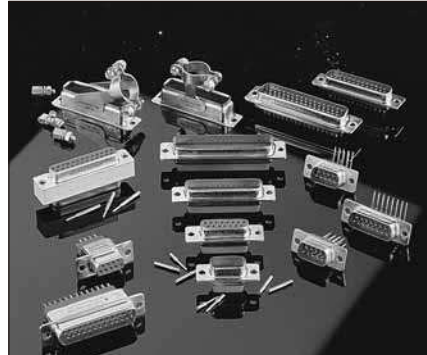

Description

D-Sub product lines conform to the MIL-DTL-24308 standard and are qualified by ESA according to ESA/SCC 3401. These products are also qualified by NASA according to GSFC.

A number of signal, power, high density and coax layouts are available, using non-magnetic shell materials.

Cross reference table for ESA/SCC/SOURIAU/GSFC

ESA/SCC P/N	SOURIAU P/N	GSFC P/N	Description
3401/001/01/B	D*M-NMB	S311-P-10	Standard density connectors with non removable contacts
3401/001/02/B	8635-NMB (spills)	-	High density connectors with non removable contacts
3401/004 *	8949 004 xx NMB	-	Coaxial contacts for SCC 3401/001/01B
3401/040 *	8949 040 xx NMB	-	Power contacts for SCC 3401/001/01B
3401/002/01/B	8630-NMB	S311-P-4/09	Standard density connectors with removable crimp contacts
3401/002/02/B	8635-NMB (crimp)	S311-P-4/07	High density connectors with removable crimp contacts
3401/005	8949 xxxx	S311-P-4/08 & /10	Crimp contacts for SCC 3401/002
3401/020/01/B	D*BMA #20	-	Standard density connectors savers with removable crimp contacts
3401/020/02/B	D*BMA #22	-	High density connectors savers with removable crimp contacts
3401/021	8949 xxxx EL	-	Savers contacts for SCC 3401/020
3401/022 *	Dx 8949 xx NM	-	Accessories (screw lock, dust caps, ...)
3401/069	8949 004 xxNMB	-	Twinax Contacts
3401/072 **	Dx 8949 xx NMB	-	Accessories (light weight backshell)

(*) These components have no ESA/SCC certification (no ESA trademark on the component).

(**) Pending ESA Qualification.

Quality Assurance Testing

• Qualification

The ESA/SCC D-Sub non-magnetic connectors are qualified to specification 3401.

• Production control

Visual (100%)

Dimensional (by sampling)

Insulation resistance (100%)

Dielectric withstanding voltage (100%)

Contact retention (100%)

Female contact capability (100%)

• Final production tests

Visual (100%)

Dimensional (by sampling)

Intermeatability

• Lot acceptance tests

Two levels are proposed according to the ESA/SC specification 3401 CHART V.

Lot acceptance level shall be specified in the purchase order.

LAT 1 _____ Environmental and mechanical sub-group

└── LAT2 _____ Endurance sub-group



CHART V - Lot Acceptance Tests

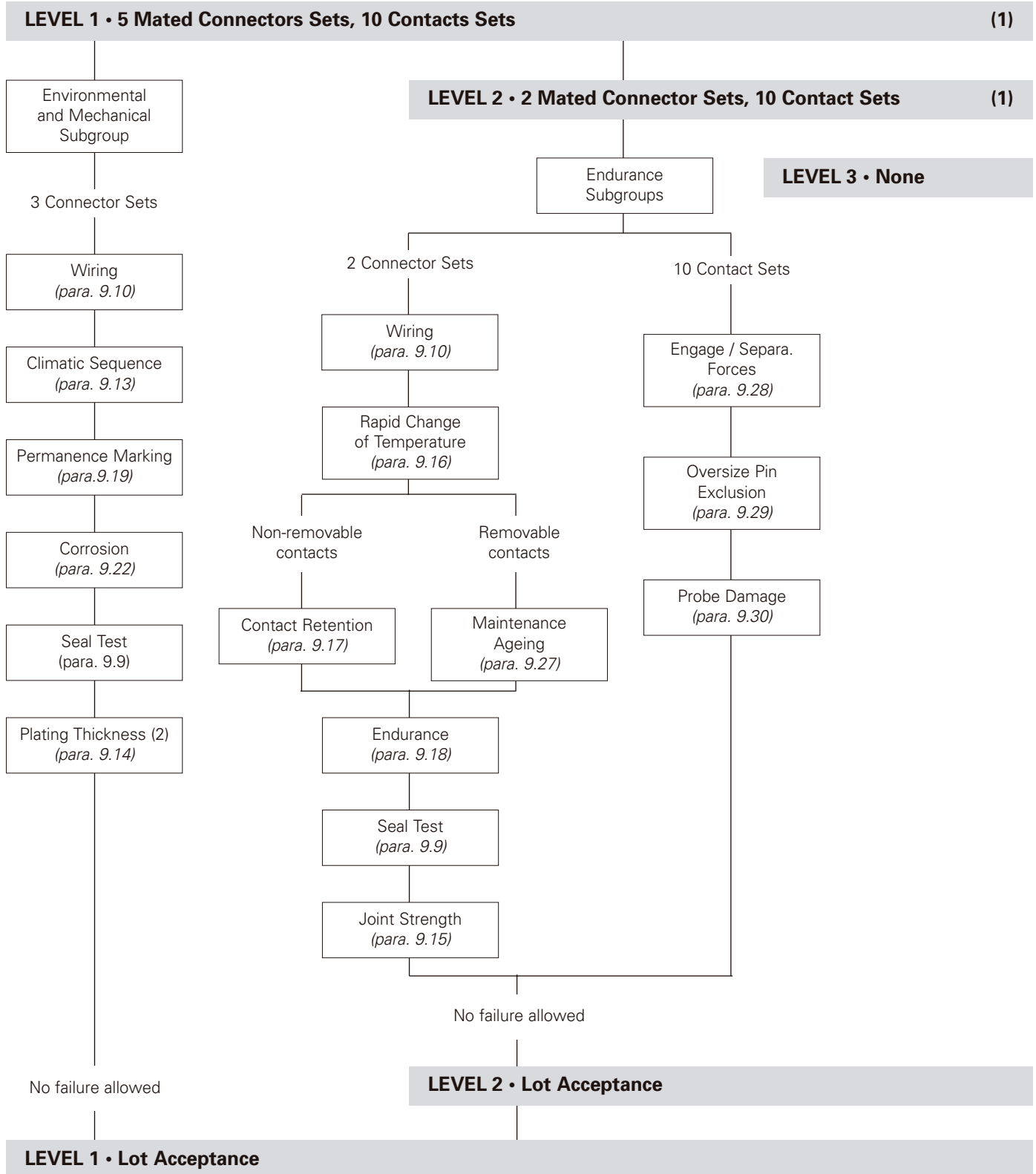

Notes :

- (1) For distribution within the sample, see Para. 8.2.2.
 - (2) Hermetic connectors only.
- All Para. refer to ESA/SCC Generic Specification n° 3401.



Materials & Finishes

Component	Material	Plating
Shells	Brass	1,27 micron gold to meet MIL/NASA - 0,7 micron gold ESA
Insulators	Diallyphtalate (according to MIL-M-14 class SGDF)	Outgassing : TML : 1% according to CVCM : 0,1% ECSS-Q-70-02A
Contacts 3401/005 /040 & /021 3401/004	Copper alloy	<ul style="list-style-type: none"> • 1,27 microns gold mini over 1 micron copper mini • 2,54 microns gold mini over 1 micron copper mini
Accessories	Brass	<ul style="list-style-type: none"> • 0,7 micron gold mini over 1 micron copper mini

Electrical characteristics

Characteristics	Symbol	Rating	Unit
Working voltage sea level (/50 Hz) <ul style="list-style-type: none"> • # 20 contacts • # 22 contacts • Power and straight coaxial contacts • 90° coaxial contacts • Twin axe 	U_R	300 250 250 200	Vrms
Dielectric Withstanding Voltage (at sea level / 33000 m) <ul style="list-style-type: none"> • # 20 and # 22 contacts • Power and Straight coaxial contacts • 90° coaxial contacts • 90° Twin ax 		1250 / 200 1000 / 100 800 / 100	Vrms
Rated current <ul style="list-style-type: none"> • # 20 and coaxial center contacts • # 22 PCB contact • # 20 crimp contact AWG 26/28 • # 22 crimp contact 	I_R	7,5 3 3 5	A
• Power contacts		Wire size	
		# 8 40 A # 10 30 A # 12 20 A # 14 15 A # 16 10 A	
Contact resistance (low level current) <ul style="list-style-type: none"> • # 20 • # 22 • Contact coaxial center and outer contact • Power 	Rcl Max.	6 6 8,5 2,5	mΩ
} under 10 mA			
Contact resistance (rated current) <ul style="list-style-type: none"> • # 20 (under 7,5 A) • # 22 PCB (under 3,0 A) • # 22 crimp (under 5,0 A) • # 20 crimp AWG 26/28 (under 3 A) • # 20 crimp (under 7,5 A) • Coaxial and power contacts (see rated current charac.) 	Rcr Max.	5 10 5 5 5 7	mΩ

Environmental characteristics

Characteristics	Rating	Unit	ESA/SCC 3401 test method
Operating temperature range	-55 to +125	°C	-
Storage temperature	1000 h/125°C	-	Para. 9.21
Thermal shock	from -55 to +125	°C	IEC 512-6 test 11d
Damp heat	10 cycles 24 h	-	IEC 68-2-30 test Dd
Mechanical endurance	500	cycles	Para. 9.18
Vibrations	20	g	IEC 512-4 test 6d
Shock	50 g with an 11 ms duration pulse	-	IEC 512-4 test 6c
Contact retention	40	N	Para. 9.17
Vacuum test (125°C/24 h)	10 ⁻⁶	Torr	ECSS-Q-70-02A



Applications

Satellite
 Launcher
 Space station
 Shuttle hardware
 Probe

Standards

ESA/SCC 3401/001/GSFC/
 MIL-DTL-24308 class M (QPL)

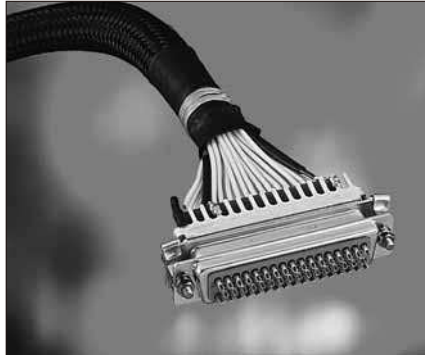

Standard density and Non removable contacts

ESA/SCC 3401/001 non-magnetic connectors are equipped with non removable contacts.

They are available with solder buckets, straight spills, 90° spills, wire wrap contacts and mixed layouts with coaxial and power contacts.

The connectors are Flight qualified parts.

Part Number / Ordering information

SCC specification number	3401 001	01	B	D	B	M	Y	9W4	P	NMB	OL3
Type Variant	01 : standard density (contact # 20)										
B Testing Level	not to be modified										
D*M series											
Shell Size	E = 9 cts ; A = 15 cts ; B = 25 cts ; C = 37 cts ; D = 50 cts										
Mounting	Without indication : fixed mounting Y : floating mounting E : 4.40 captive nuts										
Contact Layout Code	(see page 11)										
Contact Type	P : Pin (male) S : Socket (female)										
Residual Magnetism Level	NMB : ≤ 200 gammas										
Contact Termination Code											

Contact termination code

Contact terminations are indicated as follows :

Contact termination code for variant 01 (std density)		
Code for Ø 0.63	Code for Ø 0.76	Contact type
Without indication		Solder buckets
OL3	Z	Straight spills
1A0N	2A0N	90° spills, without bracket, 2,54 mm pitch between row
1B0N	2B0N	90° spills, without bracket, 2,84 mm pitch between row
1A7N	2A7N	90° spills, with bracket, with UNC 4-40 clinch nuts and 2,54 mm pitch between row
1B7N	2B7N	90° spills, with bracket, with UNC 4-40 clinch nuts and 2,84 mm pitch between row
1A9N	2A9N	90° spills, with bracket, with M3 clinch nuts and 2,54 mm pitch between row
1B9N	2B9N	90° spills, with bracket, with M3 clinch nuts and 2,84 mm pitch between row
F179A		Wire wrap termination 3 wraps

Note : Mixed layout are not available in 90° spills



Contact layouts

Contact layouts are indicated by the codes specified hereafter (male insulation front view) :

Shell size	Code	Nb cts		Layout
		# 20	# 8	
E	9	9	0	
	5W1	4	1	
A	15	15	0	
	3W3	0	3	
	3WK3*	0	3	
	7W2	5	2	
	11W1	10	1	
	B	25	25	0
5W5		0	5	
9W4		5	4	
13W3		10	3	

Shell size	Code	Nb cts		Layout
		# 20	# 8	
B	17W2	15	2	
C	37	37	0	
	8W8	0	8	
	17W5	12	5	
	21WA4	17	4	
	25W3	22	3	
	27W2	25	2	
D	50	50	0	
	24W7	17	7	
	36W4	32	4	

Standard (# 20) contact
Coaxial or power (# 8) contact

(*) : 3WK3 insulator with built-in keying (middle part recessed or protruding with respect to each side), to avoid mistmounting (K = Keying)
Available only with Space Grade version D*M, insulator material : VALOX NOT DAP.

Contact types

• Coaxial contacts 3401 004 & 8949 004 NMB

Variants	P1 * Max.	P2 ** Max.
01-02-05-06 11-12-15-16	19,60 .771	19,80 .780
09-10-19-20	22,30 .878	22,50 .886

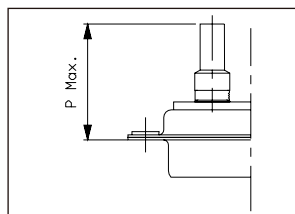

Variants	P1 * Max.	P2 ** Max.	Q Max
03-04-07-08 13-14-17-18	14,30 .563	14,50 .570	12,50 .492

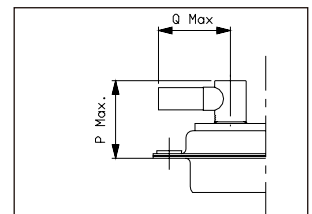

• Power contacts 3401 040 & 8949 040 NMB

Variants	P1 * Max.	P2 ** Max.
01-02-03 04-05-06	17,70 .697	17,90 .705

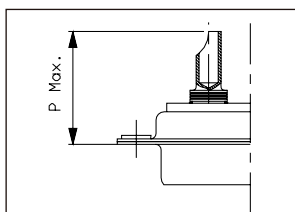

Variants	P1 * Max.	P2 ** Max.
07-08-09 10-11-12	19,80 .780	20 .787

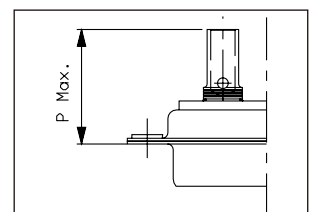

(*) P1 : for male connectors sizes E and A, and for female connectors all sizes.

(**) P2 : for male connectors sizes B, C and D.

Note : Mixed layout are not available in 90° spills



Dimensions (in mm)

Male connectors

Female connectors

Solder Bucket

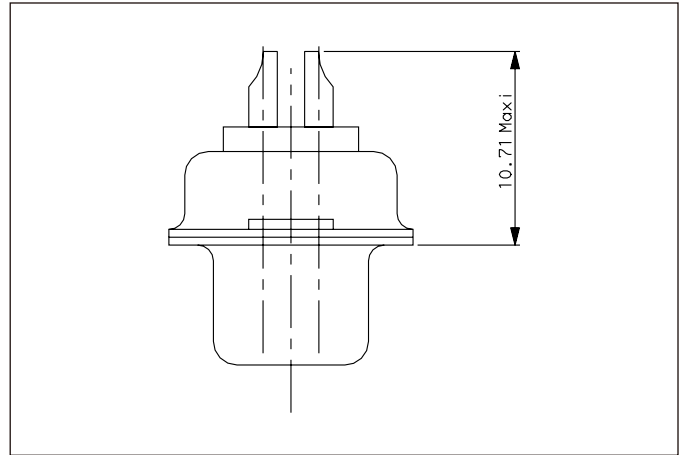
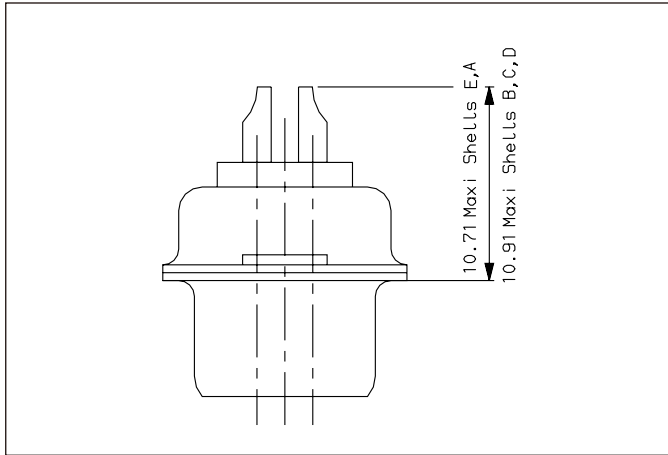

Straight spills (Z / OL3)

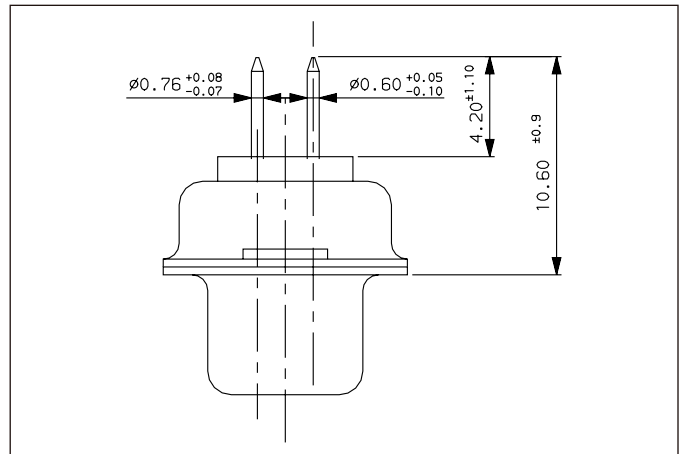
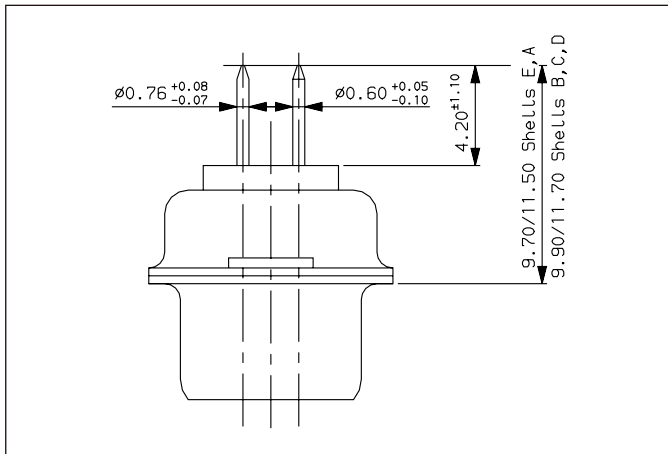

Wire wrap (F179A)

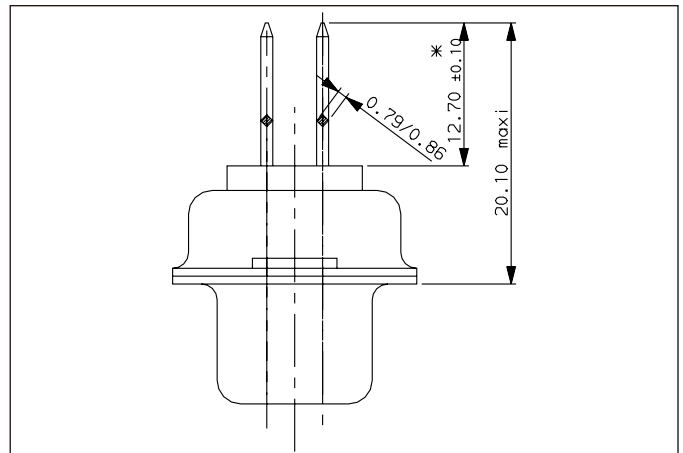
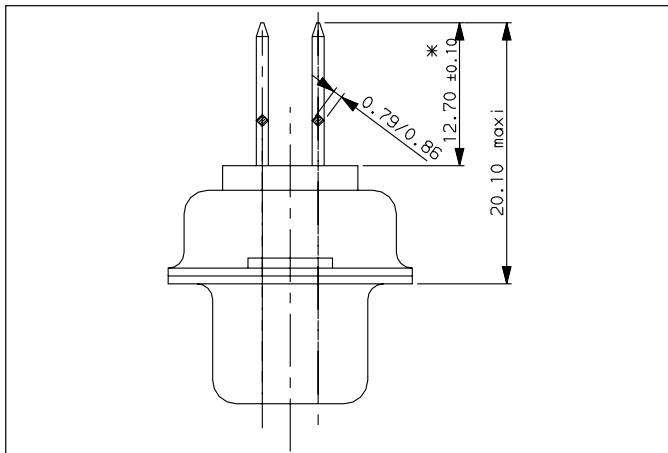

(*) The dimension is the length of the square part of the contact.



Male connectors

Female connectors

90° spills (1A0N / 2A0N / 1B0N / 2B0N)

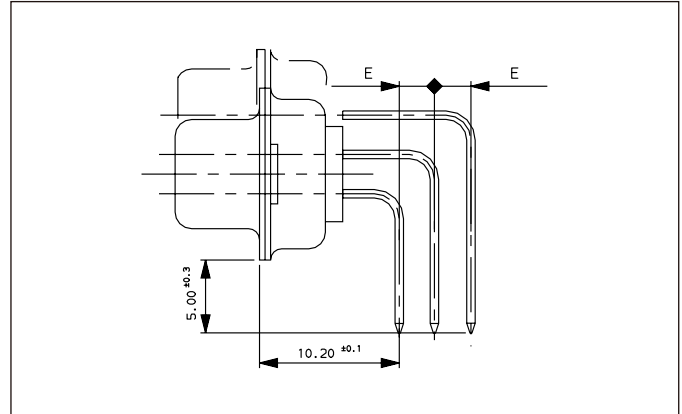
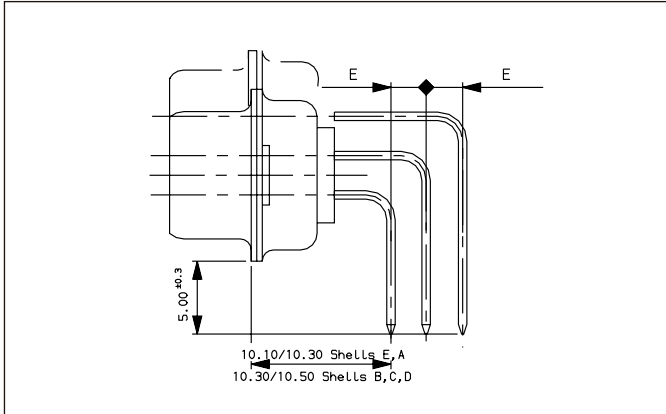

90° spills with bracket (shell size E to C)

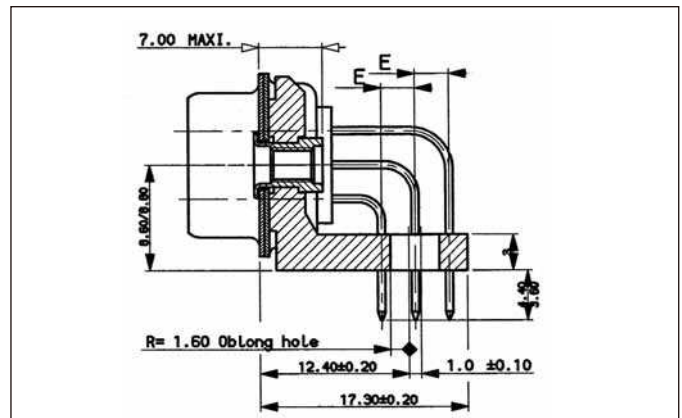
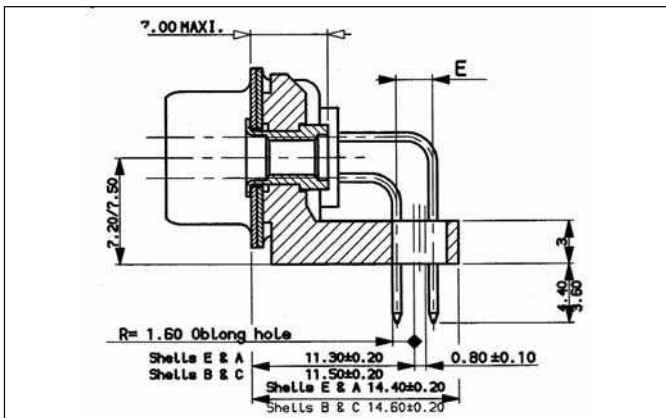

90° spills with bracket (shell size D)

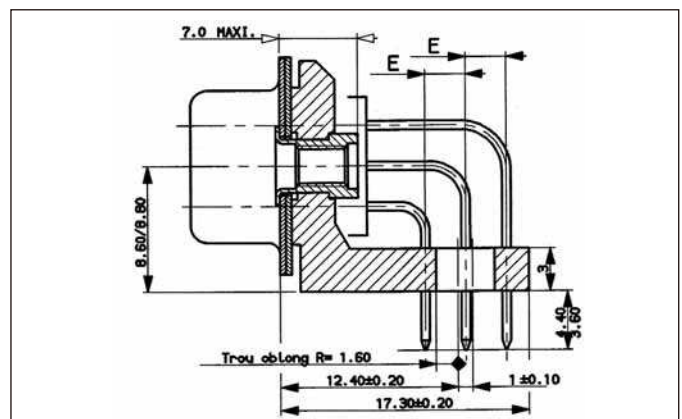
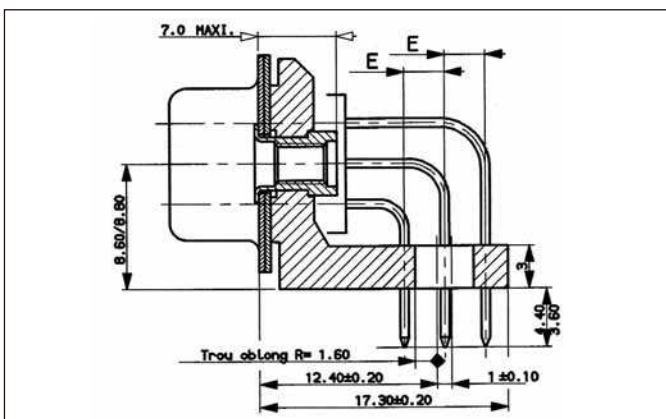

The dimensions of the 90° spills are the same as the spills for the part number 1A0N & 2A0N.

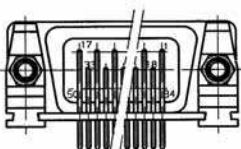

For the dimension E :

Contact termination code	E (pitch between row)
1A0N, 2A0N, 1A7N, 2A7N, 1A9N, 2A9N	2,54 mm
1B0N, 2B0N, 1B7N, 2B7N, 1B9N, 2B9N	2,84 mm



Applications

Satellite
 Launcher
 Space station
 Shuttle hardware
 Probe

Standards

ESA/SCC 3401/001/GFSC
 MIL-DTL-24308



High density and Non removable contacts

ESA/SCC 3401/001 non-magnetic connectors are equipped with non removable contacts.

They are available with straight spills, 90° spills, contacts.

The connectors are Flight qualified parts.

Part Number / Ordering information

SCC specification number	3401 001 02 B D B M Y 44 P NMB OL3
Type Variant 02 : high density (contact # 22)	
B Testing Level not to be modified	
D*M series	
Shell Size E = 15 cts ; A = 26 cts ; B = 44 cts ; C = 62 cts ; D = 78 cts	
Mounting Without indication : fixed mounting Y : floating mounting E : 4.40 captive nuts	
Contact Layout Code (see page 15)	
Contact Type P : Pin (Male) S : Socket (Female)	
Residual Magnetism Level NMB : ≤ 200 gammas	
Contact Termination Code (see table below)	

Contact termination code

Contact terminations are indicated as follows :

Contact termination code for variant 02 (high density)		
For 15 to 62 contacts (shell size : E, A, B & C)	For 78 contacts (shell size : D)	Contact type
OL3		Straight spills
1C0N	1D0N	90° spills, without bracket
1C7N	1D7N	90° spills, with bracket and UNC 4-40 clinch nuts
1C9N	1D9N	90° spills, with bracket and M3 clinch nuts



Contact layouts

Contact layouts are indicated by the codes specified hereafter (male insulation front view) :

Shell size	Code	Nb cts # 22	Layout
E	15	15	
A	26	26	
B	44	44	

Shell size	Code	Nb cts # 22	Layout
C	62	62	
D	78	78	

Dimensions (in mm)

Male connectors

Female connectors

1C7N & 1C9N (shell E to C)

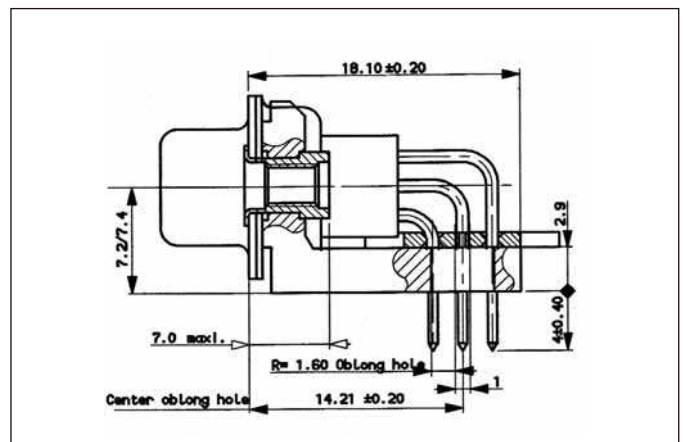
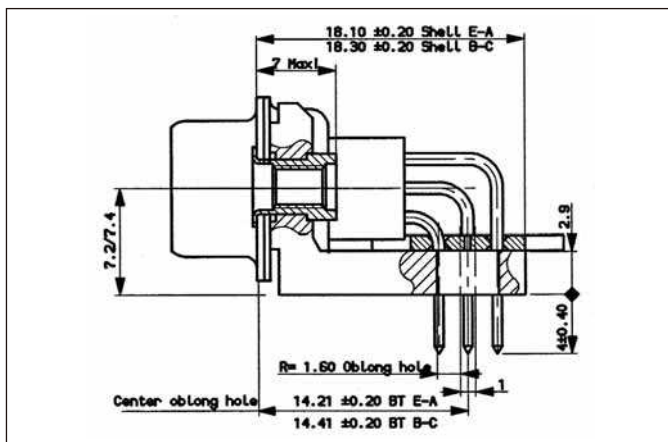

1D7N & 1D9N (shell D)

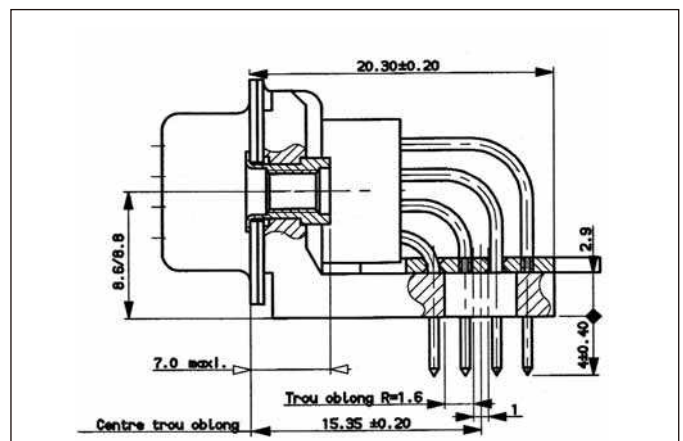
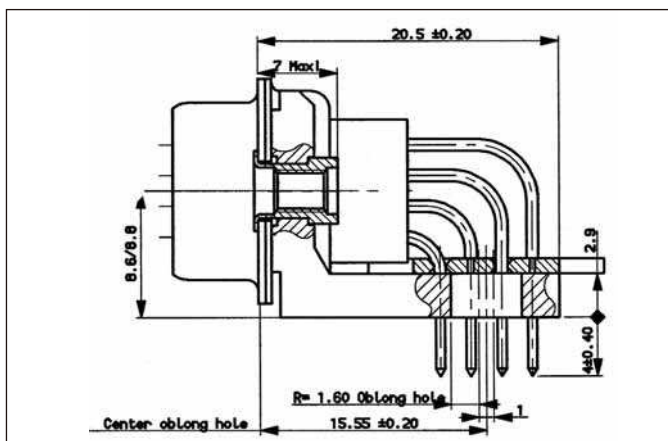

The dimensions of the 90° spills are the same as the spills for the part number 1CON & 1DON.

Rear view of the connectors ⇒

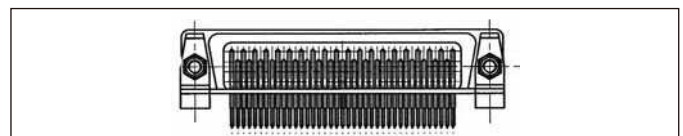



Male connectors

Female connectors

Straight spills (OL3)

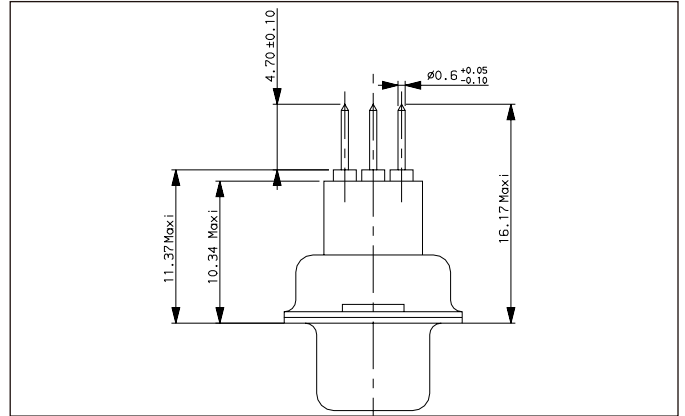
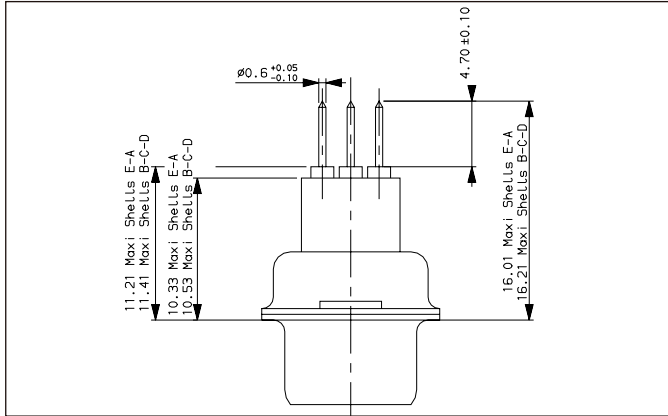

1C0N (shell size E to C)

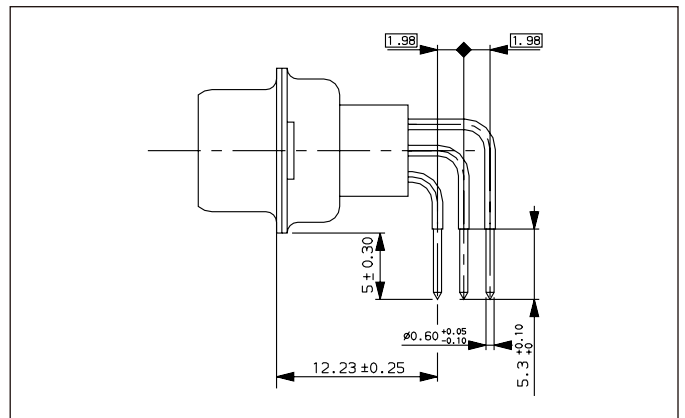
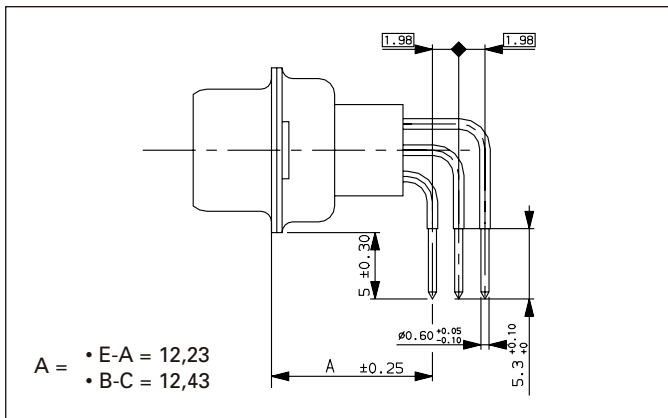

1D0N (shell size D)

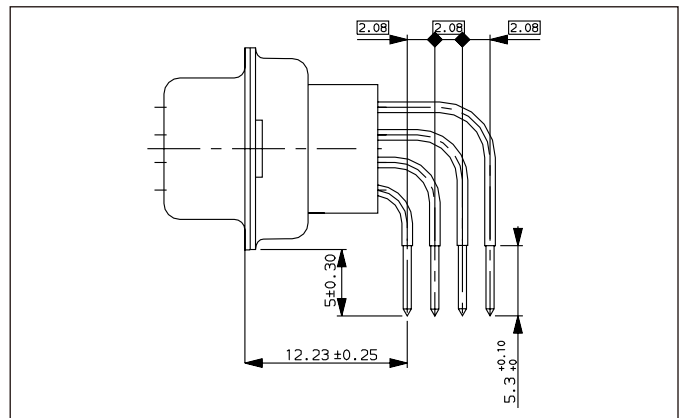
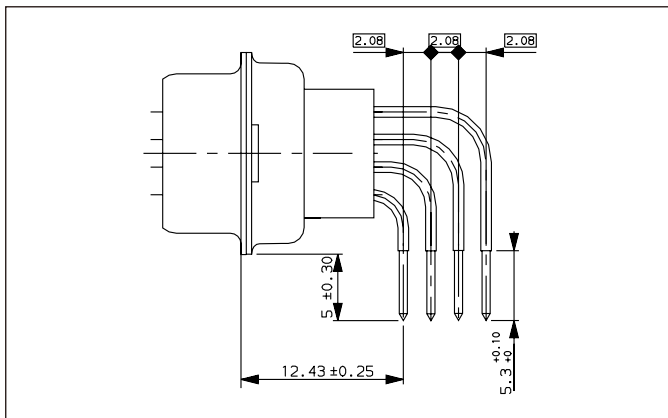

Connectors delivered with brittle drilled bar ⇒

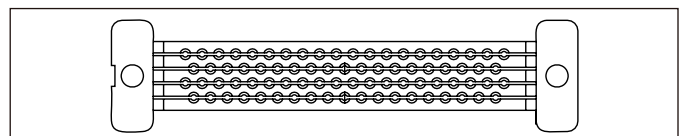

ESA/SCC 3401 002 01B



Applications

Satellite
 Launcher
 Space station
 Shuttle hardware
 Probe



Standard density & Removable Crimp Contacts

ESA/SCC 3401/002 non-magnetic connectors are used with ESA/SCC 3401/005 removable crimp contacts.

Standard density (# 20 contacts) layouts are Flight qualified parts.

Standards

ESA/SCC 3401/002/GSFC/
 MIL-DTL-24308 class M(QPL)

Part Number / Ordering information

SCC specification number	3401 002	01	B	D	B MA	Y	25	P	NMB	FO
Type variant	01 : standard density (contact # 20)									
B Testing level	not to be modified									
D*MA series										
Shell size	E = 9 cts ; A = 15 cts ; B = 25 cts ; C = 37 cts ; D = 50 cts									
Mounting	Without indication : fixed mounting Y : floating mounting E : 4.40 captive nuts. G: rear grommet									
Contact layout Code	9 cts - 15 cts - 25 cts - 37 cts - 50 cts									
Contact Type	P : Pin S : Socket									
Residual Magnetism Level	NMB : ≤ 200 gammas									
Contact Termination Code	Without indication : connectors delivered with # 20 contacts for wire AWG 20-24 FO : connectors delivered without contacts (FO is not marked on the connector)									

Contact layouts (male insulation front view)

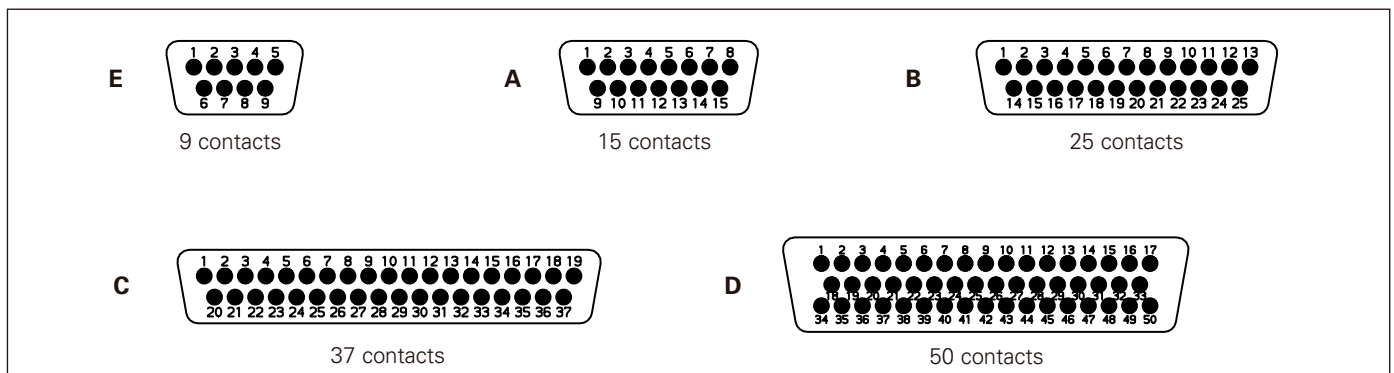



Applications

Satellite
 Launcher
 Space station
 Shuttle hardware
 Probe

Standards

ESA/SCC 3401/002/GSFC/
 MIL-DTL-24308 class M (QPL)



High Density & Removable Crimp Contacts

ESA/SCC 3401/002 non-magnetic connectors are used with ESA/SCC 3401/005 removable crimp contacts.

High density (# 22 contacts) layouts are Flight qualified parts.

Part Number / Ordering information

SCC specification number	3401 002 02 B D B MA Y 44 P NMB FO
Type Variant	02 : high density (contact # 22)
B Testing Level	not to be modified
D*MA series	
Shell Size	E = 15 cts ; A = 26 cts ; B = 44 cts ; C = 62 cts ; D = 78 cts
Mounting	Without indication : fixed mounting Y : floating mounting E : 4.40 captive nuts G : rear grommet
Contact Layout Code	15 cts - 26 cts - 44 cts - 62 cts - 78 cts
Contact Type	P : Pin S : Socket
Residual Magnetism Level	NMB : ≤ 200 gammas
Contact Termination Code	Without indication : connectors delivered with # 22 contacts for wire AWG 22-26 FO : connectors delivered without contacts (FO is not marked on the connector)

Contact layouts (male insulation front view)

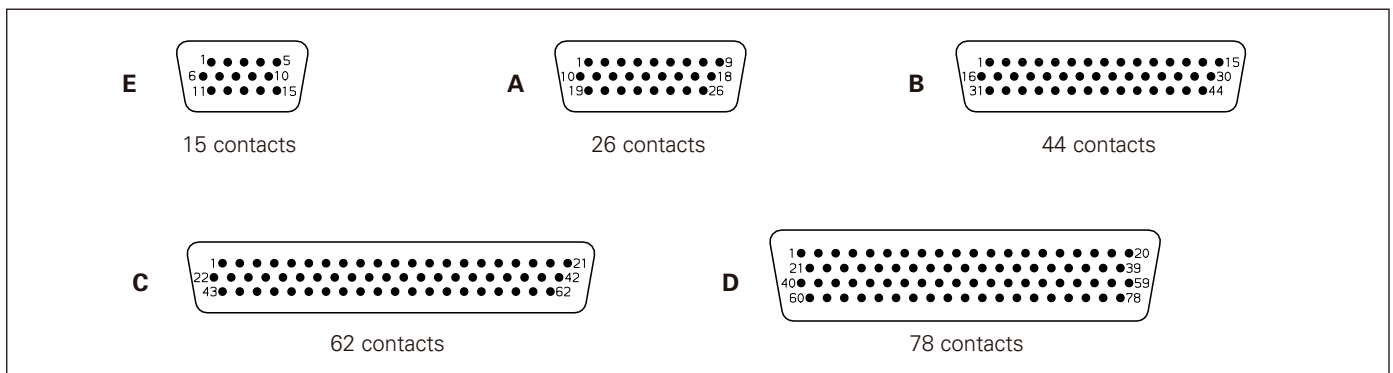

3401 020 01B & 3401 020 02B



Applications

Satellite
 Launcher
 Space station
 Shuttle hardware
 Probe



Standard and high density D-Sub savers, Removable Contacts

ESA/SCC 3401/020 savers are used to protect flight equipment connectors from multiple matings, during tests.

They are used also on a bulkhead as feed-thru connectors.

They are used with ESA/SCC 3401 021 pin-socket contacts.

These products are also suitable for Flight.

Standards

ESA/SCC 3401 020

Part Number / Ordering information

• Standard density

SCC specification number	3401 020	01	B	D	B BMA	25	PS	NMB	FO
Type Variant	01 : standard density (contact # 20)								
B Testing Level	not to be modified								
D*BMA series									
Shell Size	E = 9 cts ; A = 15 cts ; B = 25 cts ; C = 37 cts ; D = 50 cts								
Contact Layout Code	9 cts - 15 cts - 25 cts - 37 cts - 50 cts								
Contact Type	PS : Pin - Socket								
Residual Magnetism Level	NMB : ≤ 200 gammas								
Contact Termination Code	Without indication : connectors delivered with saver contact # 20 FO : connectors delivered without contacts (FO is not marked on the connector)								

• High density

SCC specification number	3401 020	02	B	D	B BMA	44	PS	NMB	FO
Type Variant	02 : high density (contact # 22)								
B Testing Level	not to be modified								
D*BMA series									
Shell Size	E = 15 cts ; A = 26 cts ; B = 44 cts ; C = 62 cts ; D = 78 cts								
Contact Layout Code	15 cts - 26 cts - 44 cts - 62 cts - 78 cts								
Contact Type	PS : Pin - Socket								
Residual Magnetism Level	NMB : ≤ 200 gammas								
Contact Termination Code	Without indication : connectors delivered with saver contact # 22 FO : connectors delivered without contacts (FO is not marked on the connector)								

See contact layouts for saver connectors p.17 for standard density and p. 18 for high density.



D*M-NMB

Applications

Satellite
Launcher
Space station
Shuttle hardware
Probe

Standards

D*M-NMB

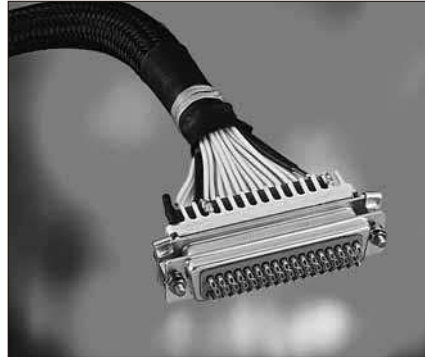

Standard density D-Sub, Non Removable Contacts (Space Grade)

D*M-NMB non-magnetic connectors use the same components as the 3401/001 ESA/SCC and S311-P-10 GSFC connectors. However they are manufactured in accordance full ESA or NASA, MIL-DTL-24308. Consequently no traceability information can be delivered for these items. They are available with solder buckets, straight spills, 90° spills, wire wrap contacts and mixed layouts with coaxial and power contacts. This version is suitable for Engineering Models as well as Flight Models.

Part Number / Ordering information

Series : D*M (contact # 20)	D	B	M	F	25	P	511	U	NMB	***
Shell Size										
E = 9 cts ; A = 15 cts ; B = 25 cts ; C = 37 cts ; D = 50 cts										
Mounting										
Nothing : standard mount										
F : float mount										
O : UNC 4-40 clinch nut										
L : M3 clinch nut										
Contact Layout Code										
(see below 11)										
Contact Type										
P : Pin (male)										
S : Socket (female)										
Contact Termination Code										
(see page 21)										
Nothing : delivered without bracket but with bar										
U : delivered with bracket & bar, but without clinch nut (*)										
Residual Magnetism and Shell Plating										
NMB : ≤ 200 gamma maximum residual magnetism : shell plated 1.27 micron gold mini over copper (conform to GSFC)										
Special Modification										

(*) **Note** : Code U only used for the 5**, 8** & 7** series.

Contact layouts

Contact layouts are indicated by the codes specified hereafter :

Shell size	Code	Nb cts # 20	Nb cts # 8
E	09	9	0
	5W1	4	1
A	15	15	0
	3W3	0	3
	3WK3	0	3
	7W2	5	2
	11W1	10	1
B	25	25	0
	5W5	0	5
	9W4	5	4
	13W3	10	3
	17W2	15	2

Shell size	Code	Nb cts # 20	Nb cts # 8
C	37	37	0
	8W8	0	8
	17W5	12	5
	21WA4	17	4
	25W3	22	3
	27W2	25	2
D	50	50	0
	24W7	17	7
	36W4	32	4

See layouts p. 11

Note : Mixed layout are not available in 90° spills



Contact termination code

Contact terminations are indicated as follows :

Contact termination code for D*M-NMB		
Code for Ø 0,63	Code for Ø 0,76	Contact type
	011	Solder bucket
311	211	Straight spills
	411	Wire wrap, 3 wraps
	711	90° spills, 2.84 mm pitch & US Footprint (2)
511	2A0N	90° spills, without bracket, 2.54 mm pitch & European Footprint (1)
811	2B0N	90° spills, without bracket, 2.84 mm pitch & European Footprint (1)
1A9N	2A9N	90° spills, with bracket, 2.54 mm pitch, M3 clinch nuts & European Footprint (1)
1B9N	2B9N	90° spills, with bracket, 2.84 mm pitch, M3 clinch nuts & European Footprint (1)
	2AUN	90° spills, with bracket, 2.54 mm pitch & European Footprint (1)
	2BUN	90° spills, with bracket, 2.84 mm pitch & European Footprint (1)
1A7N	2A7N	90° spills, with bracket, 2.54 mm pitch, # 4-40 clinch nuts & European Footprint (1)
1B7N	2B7N	90° spills, with bracket, 2.84 mm pitch, # 4-40 clinch nuts & European Footprint (1)
	2B7S	90° spills, with bracket, 2.84 mm pitch, # 4-40 clinch nuts & US Footprint (2)
	2B9S	90° spills, with bracket, 2.84 mm pitch, M3 clinch nuts & US Footprint (2)

(1) **European Footprint** : Distance from rear of flange to first row ⇒ 9.40 mm (.37 inch)
 (2) **US Footprint** : Distance from rear of flange to first row ⇒ 7.19 mm (.283 inch)

Dimensions for termination code (in mm)

Male & Female Connectors

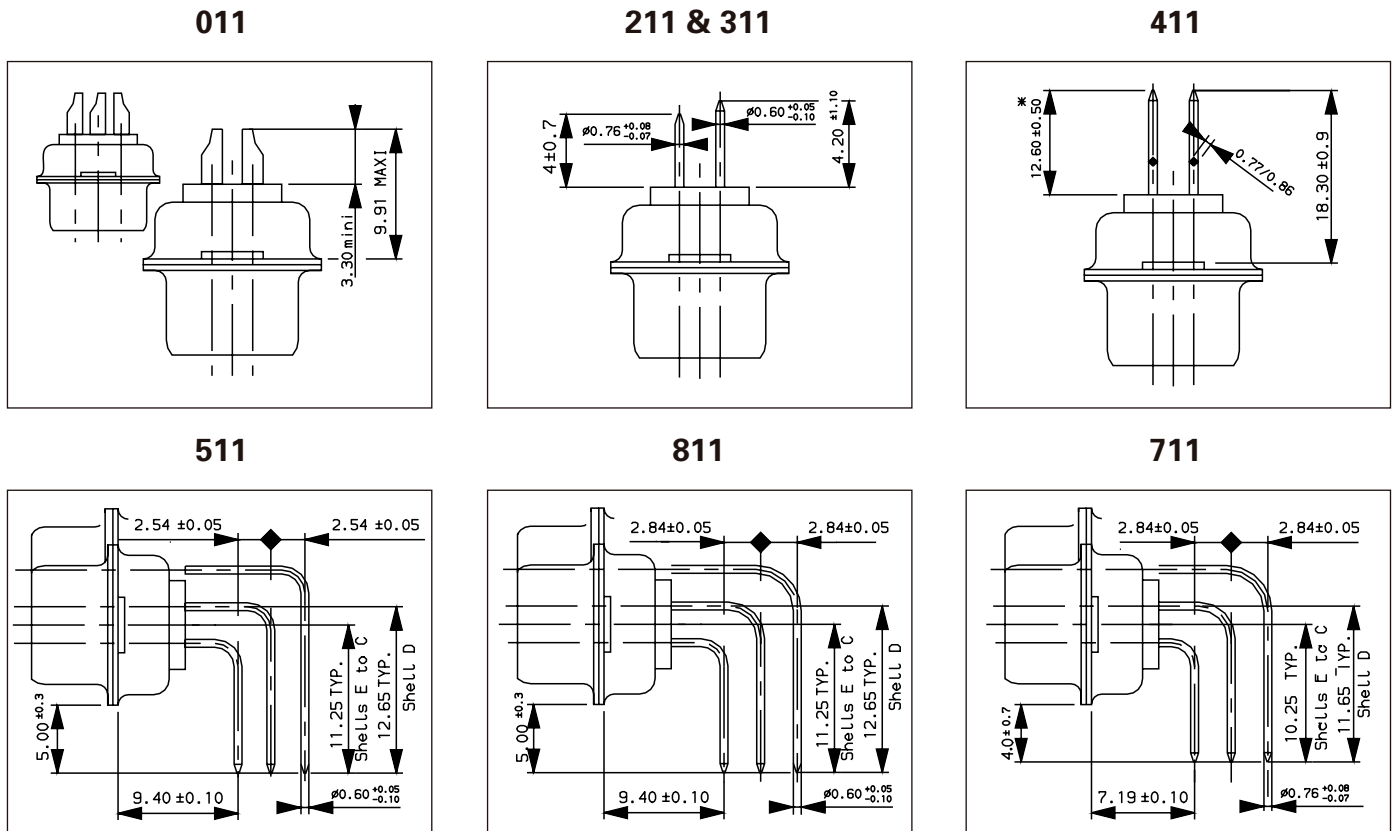

(*) The dimension is the length of the square part of the contact.



Male connectors

Female connectors

90° spills with bracket - European footprint (shell size E to C)

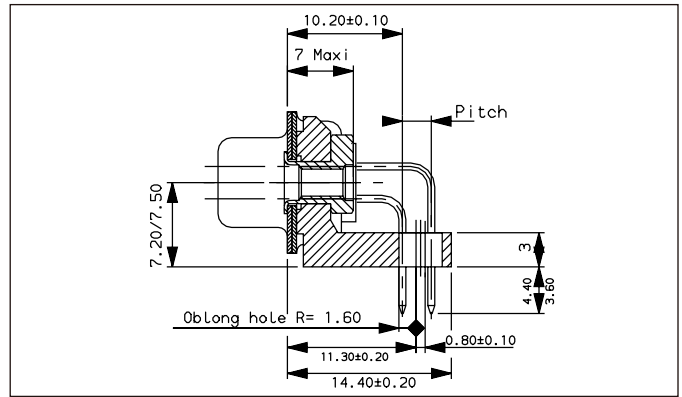
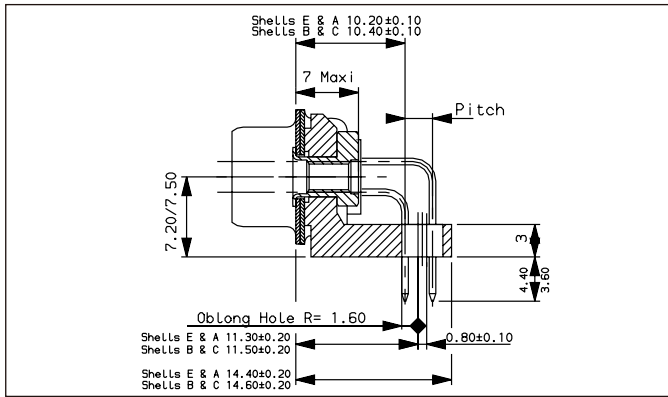

90° spills with bracket - European footprint (shell size D)

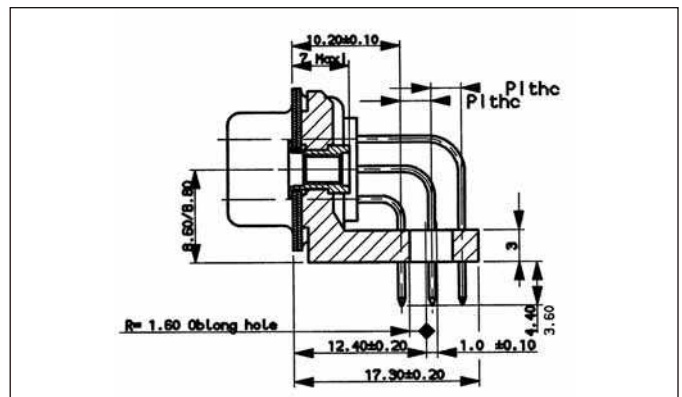
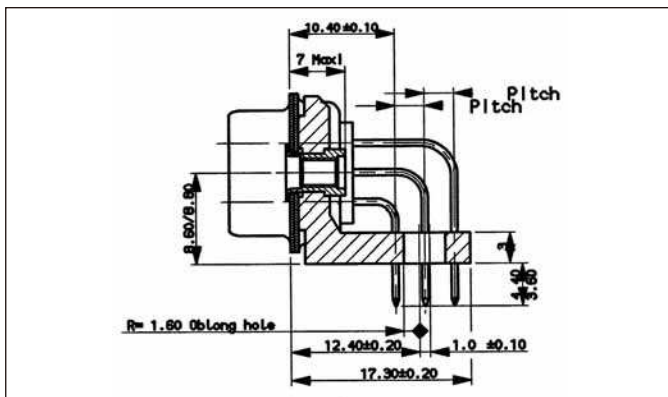

For the pitch :
 ⇒ 2,54 mm for **1A9N, 2A9N, 1A7N & 2A7N**
 ⇒ 2,84 mm for **1B9N, 2B9N, 1B7N & 2B7N**

90° spills with bracket - US footprint (711U, 2B7S & 2B9S)

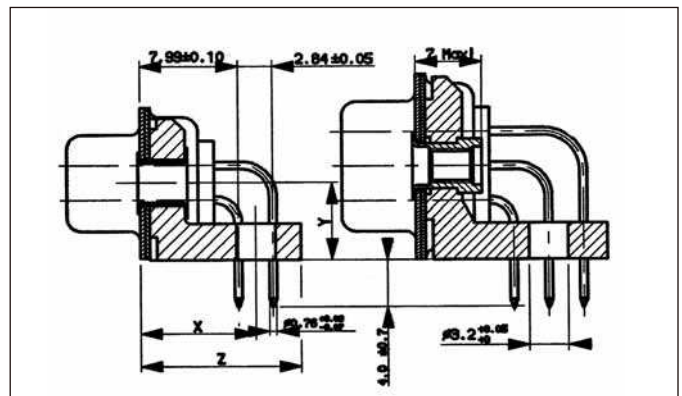
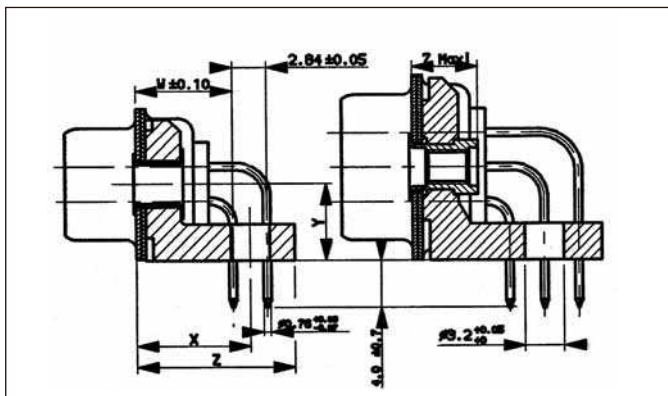

Shell size	W	X	Y	Z		
E & A	7,99 .315	9,28 .365	9,60 .378	6,34 .250	12,94 .509	13,16 .518
B & C	8,19 .322	9,48 .373	9,80 .386	6,34 .250	13,14 .517	13,36 .526
D	8,19 .322	10,87 .428	11,19 .441	7,67 .302	15,63 .615	15,85 .624

Shell size	X	Y	Z		
E to C	9,28 .365	9,60 .378	6,34 .250	12,94 .509	13,16 .518
D	10,67 .420	10,99 .433	7,67 .302	15,43 .607	15,65 .616

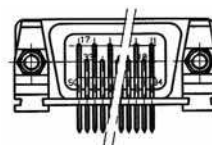

8630-NMB (Crimp)



Applications

Satellite
Launcher
Space station
Shuttle hardware
Probe

Standards

8630-NMB



Standard density D-Sub Removable Contacts (Space Grade)

8630-NMB non-magnetic connectors use the same components as the ESA/SCC 3401 001 01B and S-311-P-4/09 GSFC.

However they are manufactured in accordance with ESA NASA, MIL-DTL-24308. Consequently no traceability information can be delivered for these items. They are used with removable crimp contacts. This version is suitable for Engineering Models as well as Flight Models.

Part Number / Ordering information

Series : 8630 (standard density) # 20 contacts layouts	863	0	L	25	P	0	11	NMB	L	***
Mounting style 0 : standard mount 1 : floating mount										
Other mounting style Nothing : standard or floating mount O : UNC 4-40 clinch nuts L : M3 clinch nuts										
Contact layout Code 09 cts - 15 cts - 25 cts - 37 cts - 50 cts										
Contact Type P : Pin S : Socket										
(*) 0 : for wire # 20 to 24 R : for wire # 26 to 28 E : for wire # 18										
(*) Contact plating 11 = 1.27 micron gold over copper Note : to be indicated if connectors are ordered with contacts (no «L» at the end of the P/N)										
Residual magnetism NMB : ≤ 200 gamma maximum residual magnetism ; shell plated 1.27 micron gold mini over copper (conform to GSFC)										
(*) Without indication : connectors delivered with contacts for wire AWG 20-24 L : connectors delivered without contacts										
Special modifier										

(*) : The codes 0, 11 & L are not marked on the connector. They are only used for the P/N.

Special modifier

Code	Characteristics
601	Grommet and compound, non outgassing
604	Grommet without compound non outgassing

See layouts p. 17

8635-NMB (Spill)



Applications

Satellite
Launcher
Space station
Shuttle hardware
Probe

Standards

8635-NMB with Spill Contacts



High density D-Sub, Non Removable Contacts (Space Grade)

These 8635-NMB non-magnetic connectors use the same components as the ESA/SCC 3401 001 02B. However they are manufactured in accordance with ESA and NASA specification.

Consequently no traceability information can be delivered for these items. They are used with non removable contacts. This version is suitable for Engineering Models as well as Flight Models.

Part Number / Ordering information

Series : 8635 (high density) # 22 contacts layouts	8635	F	26	P	0L3	NMB	***
Mounting style & Grommet Nothing : standard mount F : Floating mount O : UNC 4-40 clinch nuts L : M3 clinch nuts							
Contact layout 15 cts - 26 cts - 44 cts - 62 cts - 78 cts							
Contact Type P : Pin S : Socket							
Termination type (see below)							
Residual magnetism NMB : ≤ 200 gamma maximum residual magnetism ; shell plated 1.27 micron gold mini over copper							
Special modification							

Contact termination code

Termination type	
1.27 mm shell plating	Contact type
0L3	Straight spills
1CON	90°, disposable drilled bar, 15 to 62 contacts, 1.98 pitch
1DON	90°, disposable drilled bar, 78 contacts (only D size), 2.08 pitch
1CUN	90°, with brackets, 15 to 62 contacts, 1.98 pitch (1)
1DUN	90°, with brackets, 78 contacts, 2.08 pitch (1)
1C7N	90°, with brackets and UNC 4-40 clinch nuts, 15 to 62 contacts, 1.98 pitch
1D7N	90°, with brackets and UNC 4-40 clinch nuts, 78 contacts, 2.08 pitch
1C9N	90°, with brackets and M3 clinch nuts, 15 to 62 contacts, 1.98 pitch
1D9N	90°, with brackets and M3 clinch nuts, 78 contacts, 2.08 pitch

(1) : no ESA/SCC equivalent version.

See layouts p.18

8635-NMB (Crimp)



Applications

Satellite
 Launcher
 Space station
 Shuttle hardware
 Probe

Standards

8635-NMB with Crimp Contacts



High density D-Sub Removable Contacts (Space Grade)

These 8635-NMB non-magnetic connectors use the same components as the ESA/SCC 3401 002 02B and S311-P-4/07 GSFC connectors. However they are manufactured in accordance with ESA and NASA specification. Consequently no traceability information can be delivered for these items. They are used with removable crimp contacts. This version is suitable for Engineering Models as well as Flight Models.

Part Number / Ordering information

Series : 8635 (high density) # 22 contacts layouts	8635	F	26	P	0	11	NMB	L	***
Mounting style & Grommet Nothing : standard mount F : Float mount O : UNC 4-40 clinch nuts L : M3 clinch nuts									
Contact layout Code 15 cts - 26 cts - 44 cts - 62 cts - 78 cts									
Contact Type P : Pin S : Socket									
(*) 0 : for wire # 22 to 26									
(*) Contact plating 11 : 1.27 micron gold over copper Note : to be modified if connectors are ordered with contacts (no «L» at the end of the P/N)									
Residual magnetism NMB : ≤ 200 Gamma maximum residual magnetism ; shell plated 1.27 micron gold mini over copper (conform to GSFC)									
(*) Without indication : connector delivered with contacts for wire AWG 22-26 L : connector delivered without contacts									
Special modification									

(*) : The codes 011 & L are not marked on the connector. They are only used for the P/N.

Special modifier

Code	Characteristics
601	Grommet and compound, non outgassing
604	Grommet, without compound, non outgassing

See layouts p. 18



D*BMA-NMB

Applications

Satellite
 Launcher
 Space station
 Shuttle hardware
 Probe

Standards

D*BMA-NMB



D-Sub savers (Space Grade)

D*BMA-NMB savers connectors are derived from ESA/SCC 3401 020 savers.

However they are manufactured in accordance with ESA.

Consequently no traceability information can be delivered for these items. They are used with removable crimp contacts.

This version is suitable for Engineering Models as well as Flight Models.

Part Number / Ordering information

• Standard density with removable contacts # 20

Series : D*BMA	D	B	BMA	25	PS	011	NMB	L
Shell size E = 9 cts - A = 15 cts - B = 25 cts - C = 37 cts - D = 50 cts								
Contact layout Code 09 cts - 15 cts - 25 cts - 37 cts - 50 cts								
Contact Type PS : Pin - Socket								
Contact plating 011 : 1.27 micron gold over copper								
Residual magnetism NMB : ≤ 200 Gamma maximum residual magnetism, shell plated 1.27 micron gold mini over copper								
Without indication : connectors delivered with contacts L : connectors delivered without contacts								

• High density with removable contacts # 22

Series : D*BMA	D	B	BMA	44	PS	011	NMB	L
Shell size E = 15 cts - A = 26 cts - B = 44 cts - C = 62 cts - D = 78 cts								
Contact layout Code 15 cts - 26 cts - 44 cts - 62 cts - 78 cts								
Contact Type PS : Pin - Socket								
Contact plating 011 : 1.27 micron gold over copper								
Residual magnetism NMB : ≤ 200 Gamma maximum residual magnetism, shell plated 1.27 micron gold mini over copper								
Without indication : connectors delivered with contacts L : connectors delivered without contacts								

(*) : The codes 011 & L are not marked on the connector. They are only used for the P/N.

See contact layouts for saver connectors p.17 for standard density and p.18 for high density.



Dimensions

Float mounting (3401 001, 3401 002, D*MF, 8631 & 8635F)

Not available for savers connectors

Engagement view

Male connectors

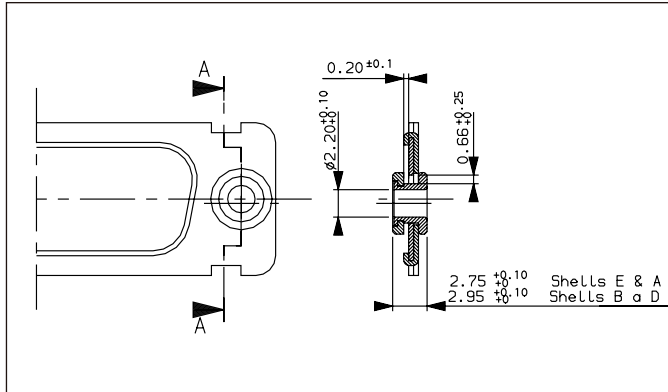

Female connectors

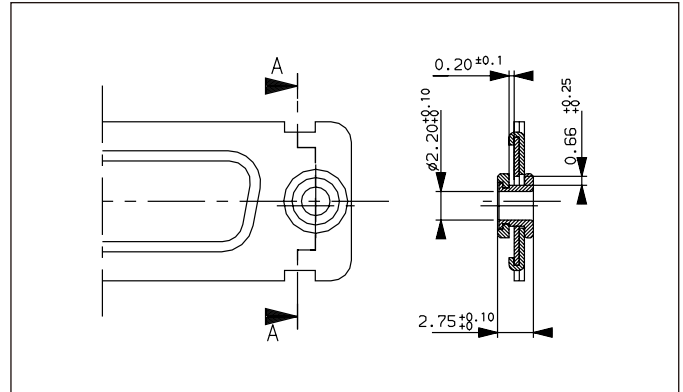

Mounting with clinch nuts (O & L, D*M, 8630 & 8635)

(E for 3401001 and 3401002 series)

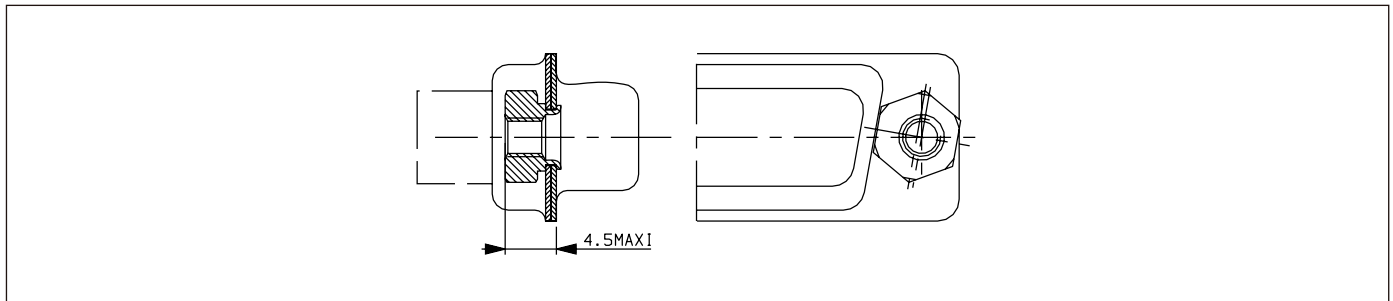

Mounting with grommet (8630 & 8635) ; (Code : G for 3401002 series),

code 601, 604 for 8630 & 8635 Space Grade version

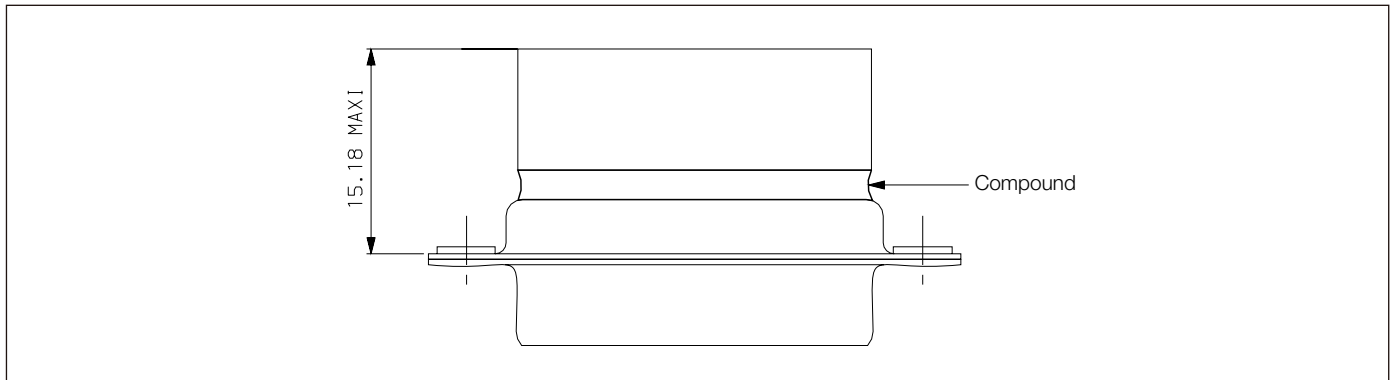



Panel cut-outs (in mm/inch)

Cutout for mounting from front or rear of panel

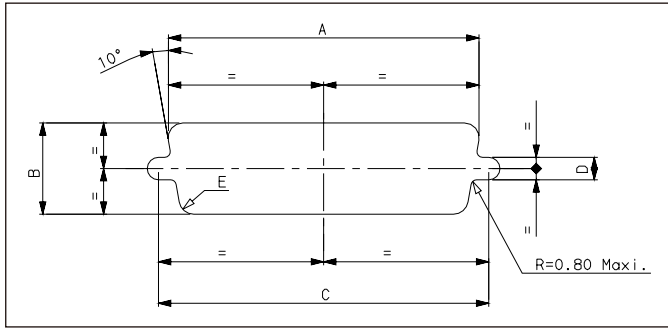

Cutout for mounting from rear of panel only

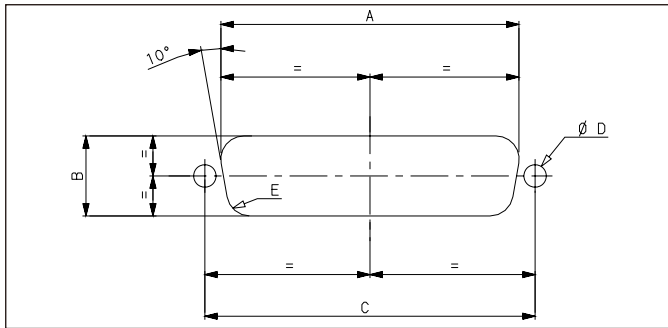

Shell size	Type of mounting	Mounting position	A ± 0,1 (± 0.004)	B ± 0,1 (± 0.004)	C ± 0,1 (± 0.004)	D ± 0,05 (± 0.002)	E ± 0,1 (± 0.004)
E	Rigid	Front	22,2 .874	13 .512	24,99 .984	3,2 .126	2,1 .083
		Rear	20,5 .807	11,4 .449	24,99 .984	3,2 .126	3,3 .130
	Float	Front	23 .906	13,8 .543	24,99 .984	2,2 .087	2,1 .083
		Rear	21,3 .839	12,2 .480	24,99 .984	2,2 .087	3,3 .130
A	Rigid	Front	30,5 1.201	13 .512	33,32 1.312	3,2 .126	2,1 .083
		Rear	28,8 1.134	11,4 .449	33,32 1.312	2,2 .087	3,3 .130
	Float	Front	31,3 1.232	13,8 .543	33,32 1.312	2,2 .087	2,1 .083
		Rear	29,6 1.165	12,2 .480	33,2 1.307	2,2 .087	3,3 .130
B	Rigid	Front	44,3 1.744	13 .512	47,04 1.852	3,2 .126	2,1 .083
		Rear	42,5 1.673	11,4 .449	47,04 1.852	3,2 .126	3,3 .130
	Float	Front	45,1 1.776	13,8 .543	47,04 1.852	2,2 .087	2,1 .083
		Rear	43,3 1.705	12,2 .480	47,04 1.852	2,2 .087	3,3 .130
C	Rigid	Front	60,7 2.390	13 .512	63,5 2.500	3,2 .126	2,1 .083
		Rear	59,1 2.327	11,4 .449	63,5 2.500	3,2 .126	3,3 .130
	Float	Front	61,5 2.421	13,8 .543	63,5 2.500	2,2 .087	2,1 .083
		Rear	59,8 2.354	12,2 .480	63,5 2.500	2,2 .087	3,3 .130
D	Rigid	Front	58,3 2.295	15,8 .622	61,11 2.406	3,2 .126	2,1 .083
		Rear	56,3 2.217	14,1 .555	61,11 2.406	3,2 .126	3,3 .130
	Float	Front	59,2 2.331	16,6 .654	61,11 2.406	2,2 .087	2,1 .083
		Rear	57,2 2.252	14,4 .567	61,11 2.406	2,2 .087	3,3 .130

Panel mounting (in mm/inch)

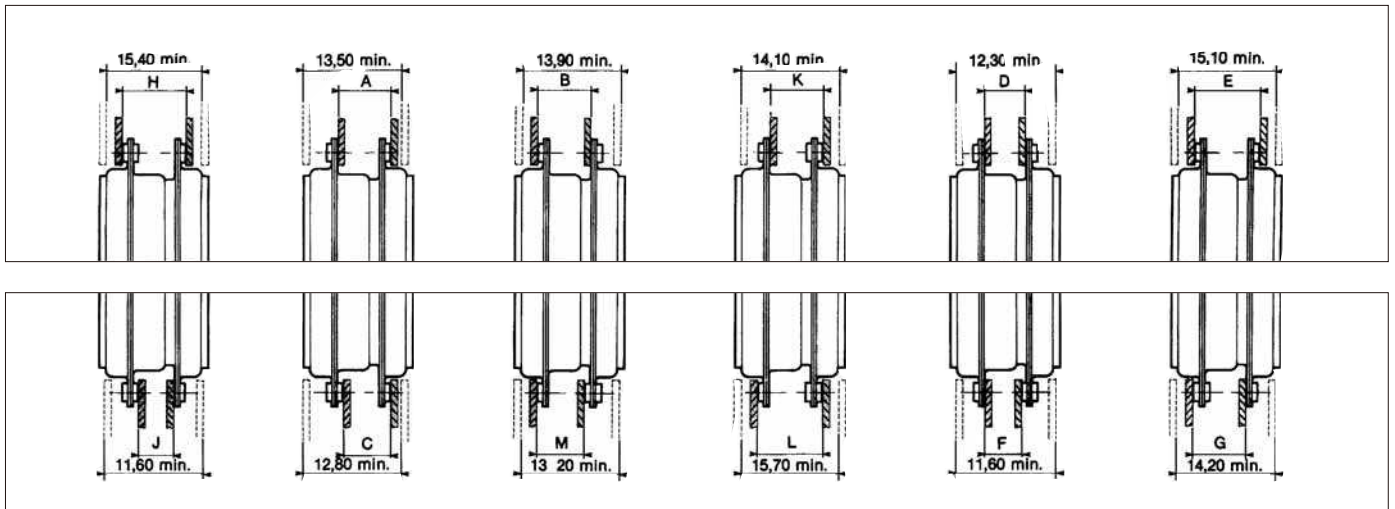

Shell size	A ^{+0,6} ₋₀	B ^{+0,6} ₋₀	C ^{+0,6} ₋₀	D ^{+0,6} ₋₀	E ^{+0,6} ₋₀	F ^{+0,6} ₋₀	G ^{+0,6} ₋₀	H ^{+0,6} ₋₀	J ^{+0,6} ₋₀	K ^{+0,6} ₋₀	L ^{+0,6} ₋₀	M ^{+0,6} ₋₀
E	7,65 .301	7,65 .301	6,85 .270	6,45 .254	8,85 .348	5,65 .222	8,25 .325	9,45 .372	5,65 .222	8,25 .325	9,45 .372	6,85 .270
A	7,65 .301	7,65 .301	6,85 .270	6,45 .254	8,85 .348	5,65 .222	8,25 .325	9,45 .372	5,65 .222	8,25 .325	9,45 .372	6,85 .270
B	7,55 .297	7,55 .297	6,75 .266	6,35 .250	8,85 .348	5,55 .219	8,15 .321	9,35 .368	5,55 .219	8,15 .321	9,35 .368	6,75 .266
C	7,55 .297	7,95 .313	6,75 .266	6,35 .250	9,15 .360	5,55 .219	8,35 .329	9,55 .376	5,55 .219	8,15 .321	9,75 .384	7,15 .281
D	7,55 .297	7,95 .313	6,75 .266	6,35 .250	9,15 .360	5,55 .219	8,35 .329	9,55 .376	5,55 .219	8,15 .321	9,75 .384	7,15 .281



Standard density

Viewed from front face of male insulator (dimensions in mm)

Layout according to	Number of contacts	Drilling dimensions
<p>MS-18273-1</p>	<p>9 contacts (shell size E)</p>	
<p>MS-18274-1</p>	<p>15 contacts (shell size A)</p>	
<p>MS-18275-1</p>	<p>25 contacts (shell size B)</p>	
<p>MS-18276-1</p>	<p>37 contacts (shell size C)</p>	
<p>MS-18277-1</p>	<p>50 contacts (shell size D)</p>	

- ⇒ Suggest 0,89 Ø hole for contact termination positions, for 0.50 / 0.65 Ø spills
- ⇒ Suggest 1,08 Ø hole for contact termination positions, for 0.69 / 0.84 Ø spills



High density

Viewed from front face of male insulator (dimensions in mm)

Layout according to	Number of contacts	Drilling dimensions	
		Male connector	Female connector
MS-18273-2	15 contacts (shell size E)		
MS-18274-2	26 contacts (shell size A)		
MS-18275-2	44 contacts (shell size B)		
MS-18276-2	62 contacts (shell size C)		
MS-18277-2	78 contacts (shell size D)		

⇒ Suggest 0,89 Ø hole for contact termination positions, for 0,50 / 0,65 Ø spills

⇒ Suggest 1,08 Ø hole for contact termination positions, for 0,69 / 0,84 Ø spills



Physical dimensions

Male connectors

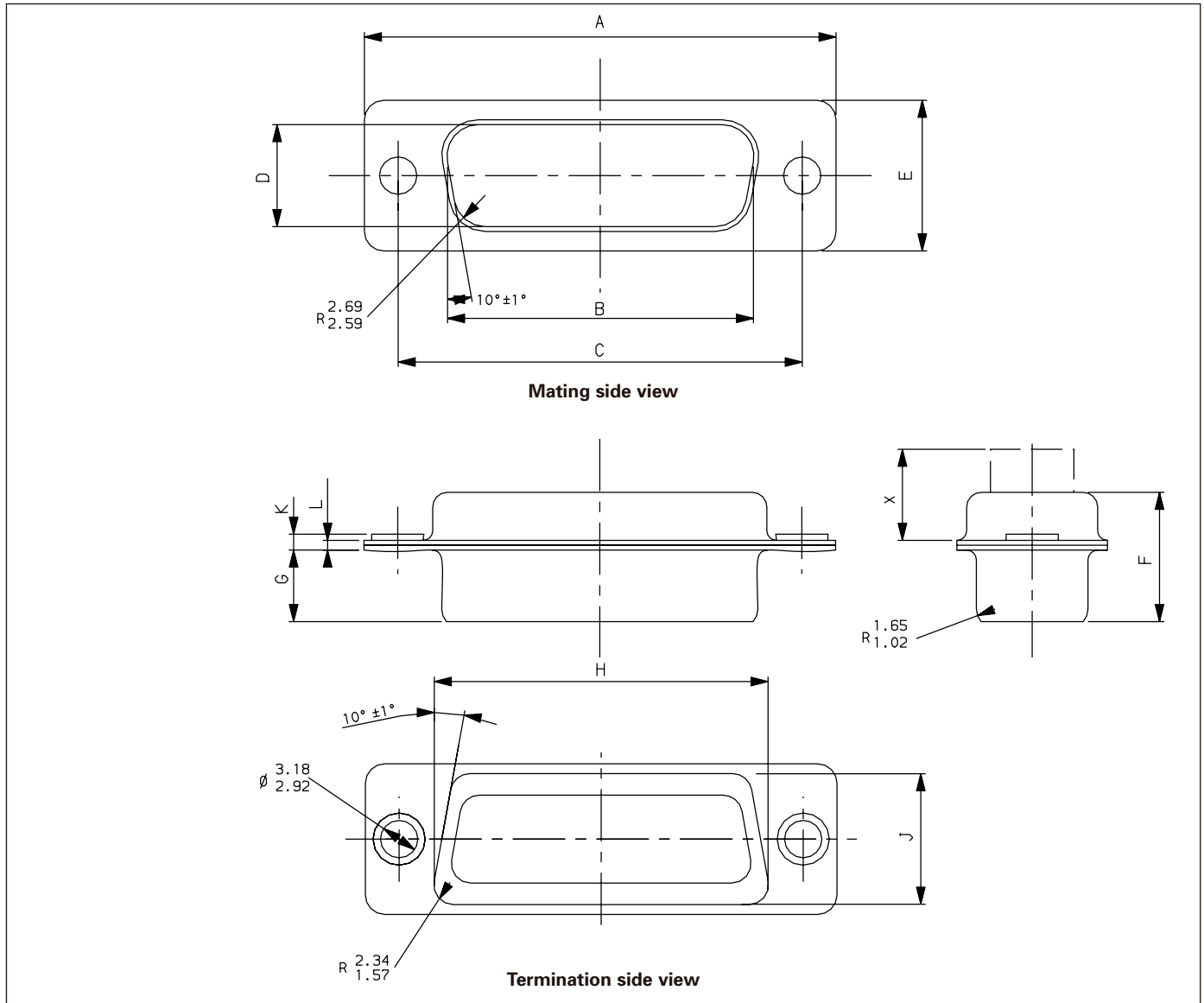

For the dimension X : ↗ 6,38 mm MAXI for **3401 001 01B & D*M**
 ↘ 9,53 mm MAXI for **3401 001 02B, 3401 002, 8630 & 8635**

Shell size	A		B		C		D		E		F		G		H		J		K		L	
	min	Max	min	Max	min	Max	min	Max	min	Max	min	Max	min	Max	min	Max	min	Max	min	Max	min	Max
E	30,43 1,198	31,19 1,228	16,79 .661	17,04 .671	24,87 .979	25,12 .989	8,23 .324	8,48 .334	12,17 .479	12,93 .509	10,46 .412	10,97 .432	5,82 .229	6,12 .241	19,02 .749	19,53 .769	10,46 .412	10,97 .432	0,89 .035	1,52 .060	0,51 .020	1,02 .040
A	38,76 1,526	39,52 1,556	25,12 .989	25,37 .999	33,20 1,307	33,45 1,317	8,23 .324	8,48 .334	12,17 .479	12,93 .509	10,46 .412	10,97 .432	5,82 .229	6,12 .241	27,25 1,073	27,76 1,093	10,46 .412	10,97 .432	0,89 .035	1,52 .060	0,51 .020	1,02 .040
B	52,65 2,073	53,42 2,103	38,84 1,529	39,09 1,539	46,91 1,847	47,17 1,857	8,23 .324	8,48 .334	12,17 .479	12,93 .509	10,57 .416	11,07 .436	5,69 .224	5,99 .236	41,02 1,615	41,53 1,635	10,46 .412	10,97 .432	1,27 .050	1,78 .070	0,74 .029	1,24 .049
C	68,94 2,714	69,70 2,744	55,30 2,177	55,55 2,187	63,37 2,495	63,63 2,505	8,23 .324	8,48 .334	12,17 .479	12,93 .509	10,57 .416	11,07 .436	5,69 .224	5,99 .236	57,45 2,262	57,96 2,282	10,46 .412	10,97 .432	1,27 .050	1,78 .070	0,74 .029	1,24 .049
D	66,55 2,620	67,31 2,650	52,68 2,074	52,93 2,084	60,99 2,401	61,24 2,411	10,95 .431	11,20 .441	14,99 .590	15,75 .620	10,57 .416	11,07 .436	5,69 .224	5,99 .236	55,07 2,168	55,58 2,188	13,31 .524	13,82 .544	1,27 .050	1,78 .070	0,74 .029	1,24 .049



Physical dimensions

Female connectors

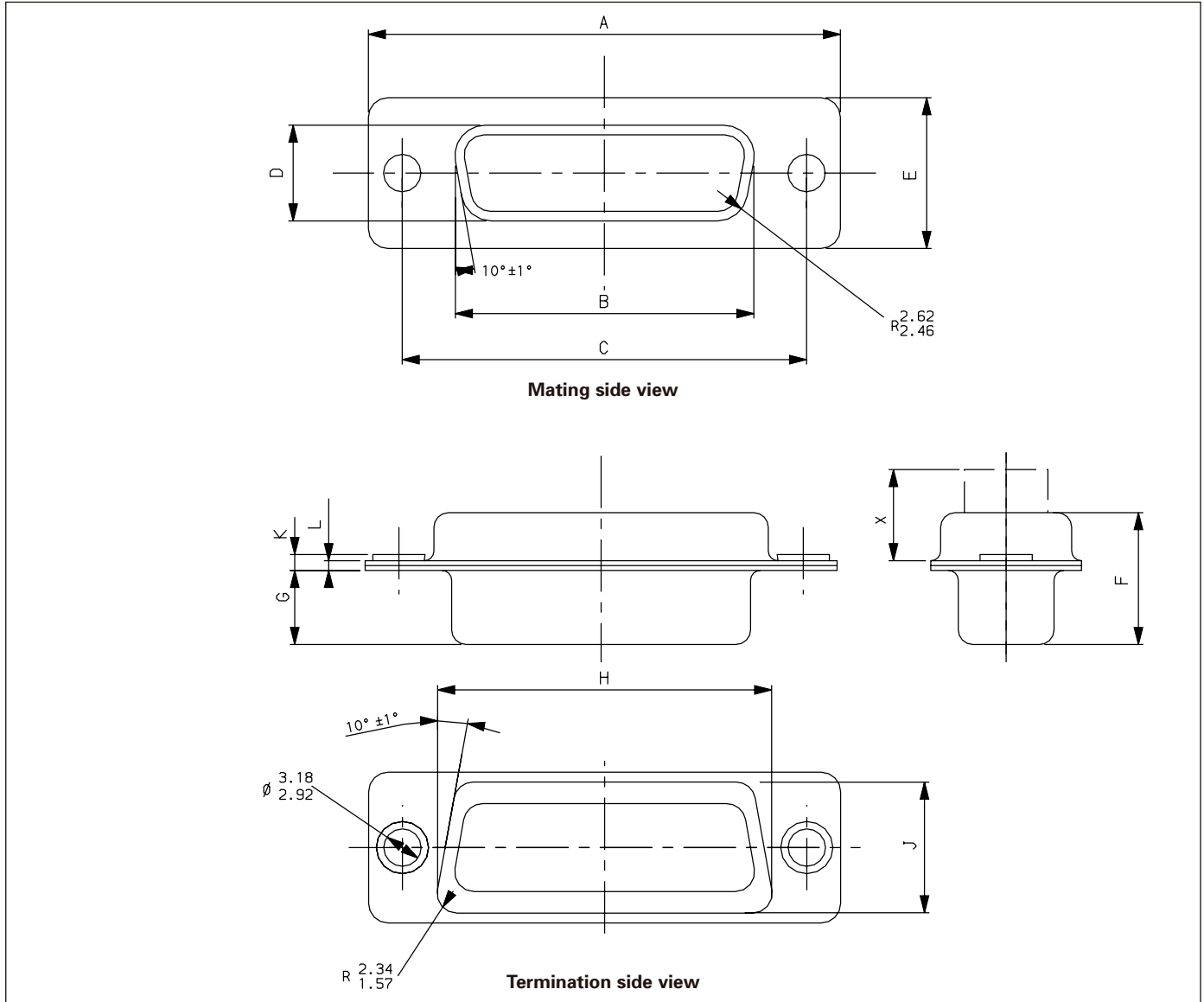

For the dimension X : ↗ 6,38 mm MAXI for **3401 001 01B & D*M**
 ↘ 9,53 mm MAXI for **3401 001 02B, 3401 002, 8630 & 8635**

Shell size	A		B		C		D		E		F		G		H		J		K		L	
	min	Max	min	Max	min	Max	min	Max	min	Max	min	Max	min	Max	min	Max	min	Max	min	Max	min	Max
E	30,43 1,198	31,19 1,228	16,21 .638	16,46 0,648	24,87 .979	25,12 .989	7,77 .306	8,03 .316	12,17 .479	12,93 .509	10,64 .419	11,15 .439	6,05 .238	6,30 .248	19,02 .749	19,53 .769	10,46 .412	10,97 .432	0,89 .035	1,52 .060	0,51 .020	1,02 .040
A	38,76 1,526	39,52 1,556	24,54 .966	24,79 .976	33,20 1,307	33,45 1,317	7,77 .306	8,03 .316	12,17 .479	12,93 .509	10,64 .419	11,15 .439	6,05 .238	6,30 .248	27,25 1,073	27,76 1,093	10,46 .412	10,97 .432	0,89 .035	1,52 .060	0,51 .020	1,02 .040
B	52,65 2,073	53,42 2,103	38,25 1,506	38,51 1,516	46,91 1,847	47,17 1,857	7,77 .306	8,03 .316	12,17 .479	12,93 .509	10,64 .419	11,15 .439	6,05 .238	6,30 .248	41,02 1,615	41,53 1,635	10,46 .412	10,97 .432	0,89 .035	1,52 .060	0,51 .020	1,02 .040
C	68,94 2,714	69,69 2,744	54,71 2,154	54,97 2,164	63,37 2,495	63,63 2,505	7,77 .306	8,03 .316	12,17 .479	12,93 .509	10,64 .419	11,15 .439	6,05 .238	6,30 .248	57,45 2,262	57,96 2,282	10,46 .412	10,97 .432	0,89 .035	1,52 .060	0,51 .020	1,02 .040
D	66,55 2,620	67,31 2,650	52,30 2,059	52,55 2,069	60,99 2,401	61,24 2,411	10,62 .418	10,87 .428	14,99 .590	15,75 .620	10,64 .419	11,15 .439	6,05 .238	6,30 .248	55,07 2,168	55,58 2,188	13,31 .524	13,82 .544	0,89 .035	1,52 .060	0,51 .020	1,02 .040



Saver connectors

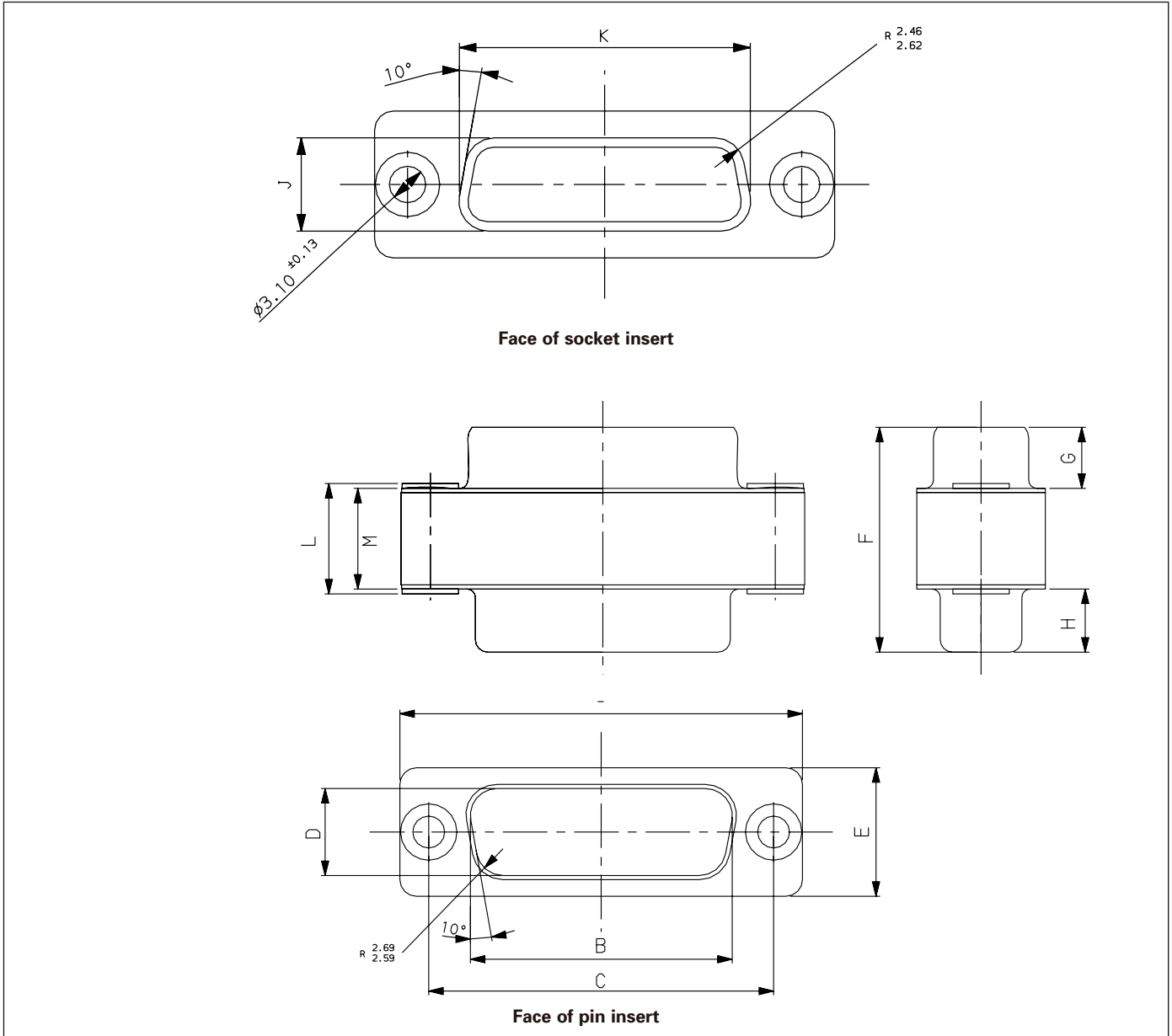

Shell size	A		B		C		D		E		F		G		H		J		K		L		M	
	min	Max	min	Max	min	Max	min	Max	min	Max	min	Max	min	Max	min	Max	min	Max	min	Max	min	Max	min	Max
E	66,55 2,620	67,31 2,650	52,68 2,074	52,93 2,084	60,99 2,401	61,24 2,411	10,95 .431	11,20 .441	14,99 .590	15,75 .620	21,72 .855	22,22 .875	5,69 .224	5,99 .236	6,05 .238	6,30 .248	10,62 .418	10,87 .428	52,30 2,059	52,55 2,069	10,21 .402	10,97 .432	9,61 .378	10,11 .398
A	68,94 2,714	69,70 2,744	55,30 2,177	55,55 2,187	63,37 2,495	63,63 2,505	8,23 .324	8,48 .334	12,17 .479	12,93 .509	21,72 .855	22,22 .875	5,69 .224	5,99 .236	6,05 .238	6,30 .248	7,77 .306	8,03 .316	54,71 2,154	54,97 2,164	10,21 .402	10,97 .432	9,61 .378	10,11 .398
B	52,65 2,073	53,42 2,103	38,84 1,529	39,09 1,539	46,91 1,847	47,17 1,857	8,23 .324	8,48 .334	12,17 .479	12,93 .509	21,72 .855	22,22 .875	5,69 .224	5,99 .236	6,05 .238	6,30 .248	7,77 .306	8,03 .316	38,25 1,506	38,51 1,516	10,21 .402	10,97 .432	9,61 .378	10,11 .398
C	38,76 1,526	39,52 1,556	25,12 .989	25,37 .999	33,20 1,307	33,45 1,317	8,23 .324	8,48 .334	12,17 .479	12,93 .509	21,12 .831	21,62 .851	5,82 .229	6,12 .241	6,05 .238	6,30 .248	7,77 .306	8,03 .316	24,54 .966	24,79 .976	10,21 .402	10,97 .432	9,61 .378	10,11 .398
D	30,43 1,198	31,19 1,228	16,79 .661	17,04 .671	24,87 .979	25,12 .989	8,23 .324	8,48 .334	12,17 .479	12,93 .509	21,12 .831	21,62 .851	5,82 .229	6,12 .241	6,05 .238	6,30 .248	7,77 .306	8,03 .316	16,21 .638	16,46 .648	10,21 .402	10,97 .432	9,61 .378	10,11 .398



Crimp contacts

- **3401 005** : crimp contacts for **3401 002** connectors (Flight Models)
- **8949 Series** : crimp contacts for **8630 / 8635** connectors (Engineering Models).

Contact Size	Designation		Part number / ordering code (see note)		
			ESA/SCC	NMB / 011 SOURIAU (1.27 microns gold)	NMB / 038 SOURIAU (2.54 microns gold)
# 20	# 20/24	Pin	3401 005 01B	8949 1196 Y7 EL	8949 1196 UE EL
		Socket	3401 005 02B	8949 1198 EL	8949 407 EL
# 20	# 26/28	Pin	3401 005 03B	8949 1520 Y7 EL	8949 1520 UE EL
		Socket	3401 005 04B	8949 1523 EL	8949 1521 EL
# 20	# 18	Pin	3401 005 05B	8949 3227 Y7 EL	8949 3227 UE EL
		Socket	3401 005 06B	8949 3352 EL	8949 3229 EL
# 22	# 22/26	Pin	3401 005 07B	8949 1524 Y7 EL	8949 1524 UE EL
		Socket	3401 005 08B	8949 1525 EL	8949 1526 EL

Note : the code EL is not marked on the packaging

Insertion & Extraction tool

	Part number
Plastic tool for # 20	8630-06A
Plastic tool for # 22	M 81969-14-01

Removable contact identification

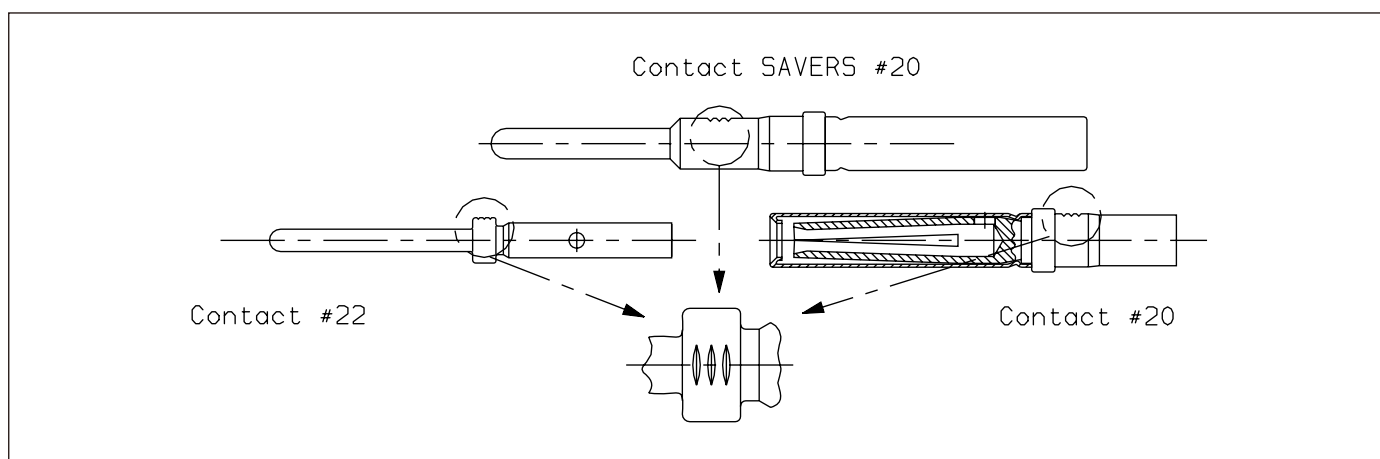

Saver contacts

- **3401 021** : crimp contacts for **3401 020** connectors (Flight Models)
- **8949 Series** : crimp contacts for **D*BMA** connectors (Engineering Models).

Contact Size	Designation	ESA/SCC	Part number	
			NMB / 011 (1.27 microns gold)	NMB / 038 (2.54 microns gold)
# 20	Pin - Socket	3401 021 01B	8949 975 EL	8949 3030 EL
# 22	Pin - Socket	3401 021 02B	8949 3362 EL	8949 3373 EL



Coaxial contacts

3401 004/8949-004 & 3401 040/8949-040 Contact identification

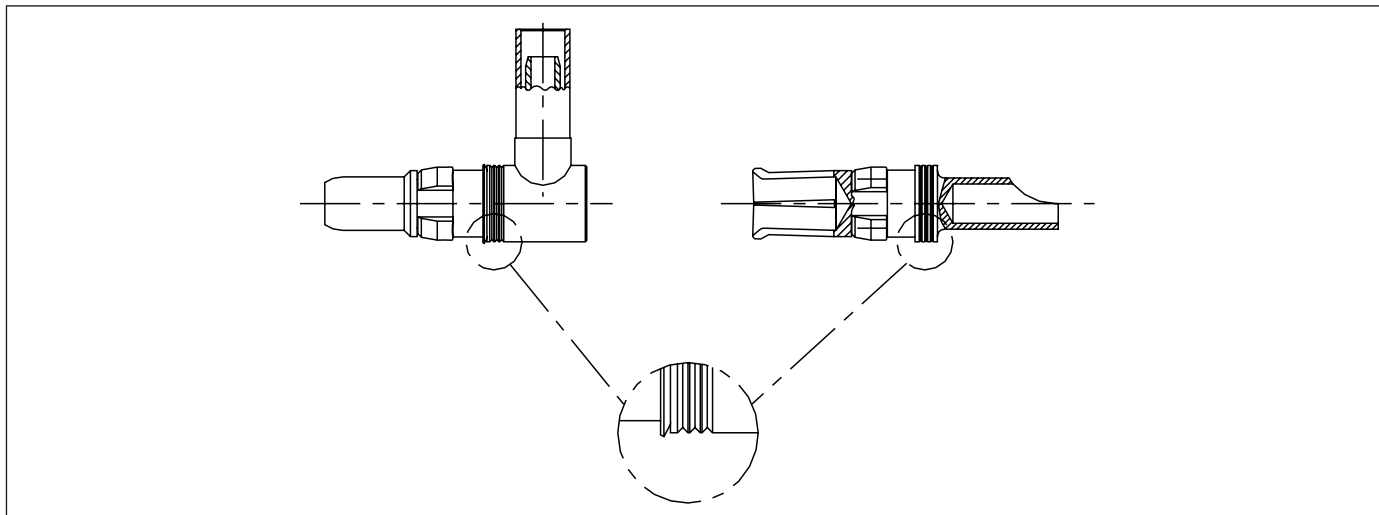

SOURIAU's contacts are identified by 3 engraved stripes.

Part Numbers

Version	ESA Part Number system (Flight Models)	SOURIAU Part Number system (Engineering Models)	Type	Shape	Wire type
Solder buckets	3401 004 01B	8949 004 01NMB	Male	straight	RG 178 BU RG 196 AU KX 21 A
	3401 004 02B	8949 004 02NMB	Female	straight	
	3401 004 03B	8949 004 03NMB	Male	90°	
	3401 004 04B	8949 004 04NMB	Female	90°	
	3401 004 05B	8949 004 05NMB	Male	straight	KX 22 A RG 179 BU RG 316 U RG 188 AU & 50 CIS
	3401 004 06B	8949 004 06NMB	Female	straight	
	3401 004 07B	8949 004 07NMB	Male	90°	
	3401 004 08B	8949 004 08NMB	Female	90°	
	3401 004 09B	8949 004 09NMB	Male	straight	RG 180 BU
	3401 004 10B	8949 004 10NMB	Female	straight	
Crimp contacts	3401 004 11B	8949 004 11NMB	Male	straight	RG 178 BU RG 196 AU KX 21 A
	3401 004 12B	8949 004 12NMB	Female	straight	
	3401 004 13B	8949 004 13NMB	Male	90°	
	3401 004 14B	8949 004 14NMB	Female	90°	
	3401 004 15B	8949 004 15NMB	Male	straight	KX 22 A RG 179 BU RG 316 U RG 188 AU & 50 CIS
	3401 004 16B	8949 004 16NMB	Female	straight	
	3401 004 17B	8949 004 17NMB	Male	90°	
	3401 004 18B	8949 004 18NMB	Female	90°	
	3401 004 19B	8949 004 19NMB	Male	straight	RG 180 BU
	3401 004 20B	8949 004 20NMB	Female	straight	
50 CIS				according to ESA/SCC 3902 001	
RG 176 B/U, RG 178 B/U, RG 179 B/U, RG 180 B/U, RG 196 A/U, RG 316 U, RG 188 A/U				according to MIL-C-17	
KX 21 A / 22 A				according to NFC 93550	

Extraction tool

	Part number
Extraction tool	8630-07A



Coaxial contacts

Dimensions (in mm/inch)

Pin coaxial contact

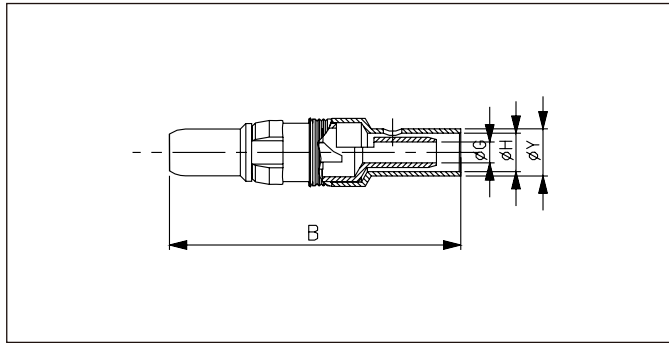

01, 05, 11 & 15 variants

Socket coaxial contact

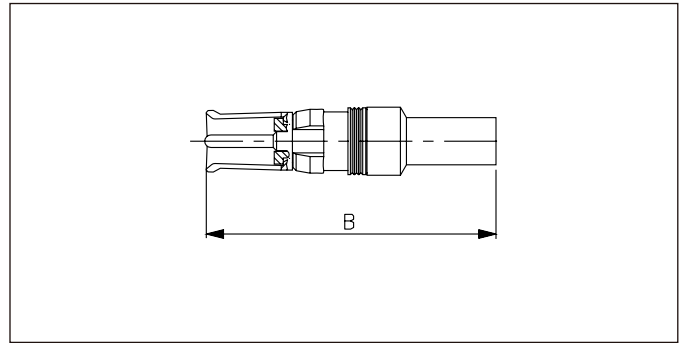

02, 06, 12 & 16 variants

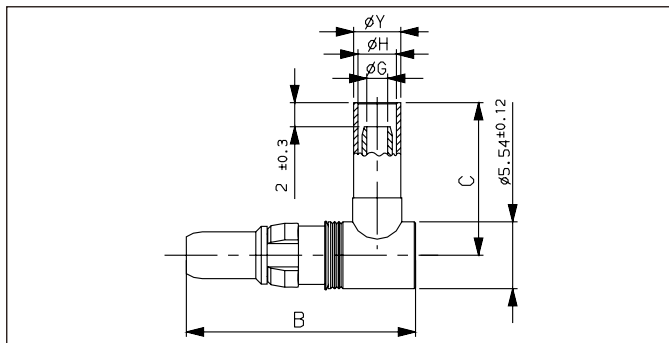

03, 07, 13 & 17 variants

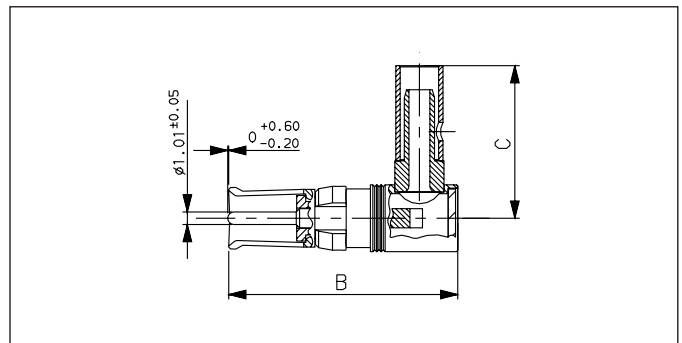

04, 08, 14 & 18 variants

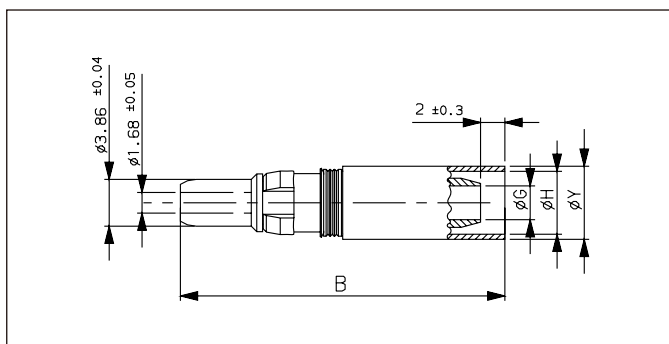

09 & 19 variants

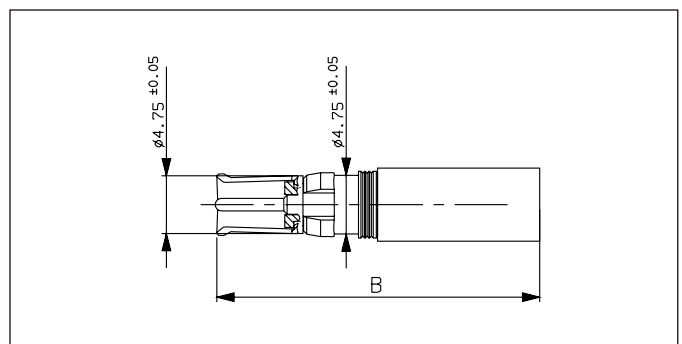

10 and 20 variants

Variant	B Ref.	C Ref.	Ø G min	Ø H min	X Max.	Ø Y Max.
01 - 11	23,6 .929	-	0,9 .035	2,3 .091	18,8 .74	3,25 .128
02 - 12	23,6 .929	-	0,9 .035	2,3 .091	18,8 .74	3,25 .128
03 - 13	18,64 .734	12,5 .492	0,9 .035	2,3 .091	13,46 .53	3,25 .128
04 - 14	18,64 .734	12,5 .492	0,9 .035	2,3 .091	13,46 .53	3,25 .128
05 - 15	23,6 .929	-	1,55 .061	3,1 .122	18,8 .74	4,1 .161
06 - 16	23,6 .929	-	1,55 .061	3,1 .122	18,8 .74	4,1 .161
07 - 17	18,64 .734	12,5 .492	1,55 .061	3,1 .122	13,46 .53	4,1 .161
08 - 18	18,64 .734	12,5 .492	1,55 .061	3,1 .122	13,46 .53	4,1 .161
09 - 19	26,3 1.035	-	2,55 .1	5,1 .201	21,5 .846	6,2 .244
10 - 20	26,3 1.035	-	2,55 .1	5,1 .201	21,5 .846	6,2 .244



Power solder contacts

Part Numbers

Version	ESA part number (Flight Models)	SOURIAU part number (Engineering Models)	Type	Wire Size (AWG)
Solder buckets	3401 040 01B	8949 040 01NMB	Male	8
	3401 040 02B	8949 040 02NMB	Female	8
	3401 040 03B	8949 040 03NMB	Male	12
	3401 040 04B	8949 040 04NMB	Female	12
	3401 040 05B	8949 040 05NMB	Male	16
	3401 040 06B	8949 040 06NMB	Female	16

Dimensions (in mm/inch)

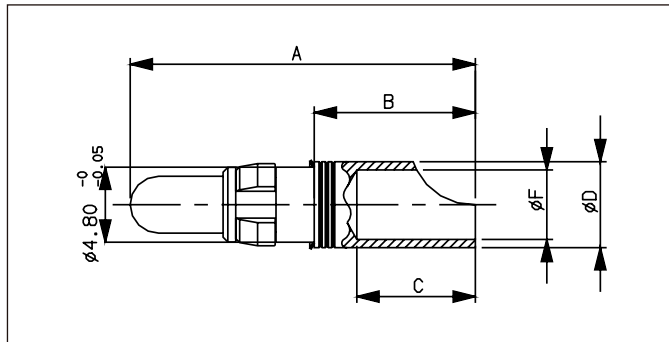

Variant 01

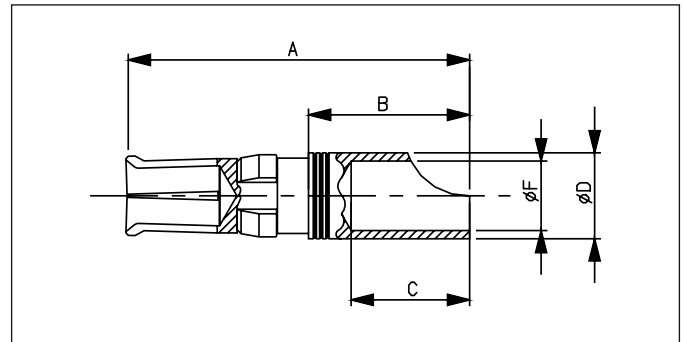

Variant 02

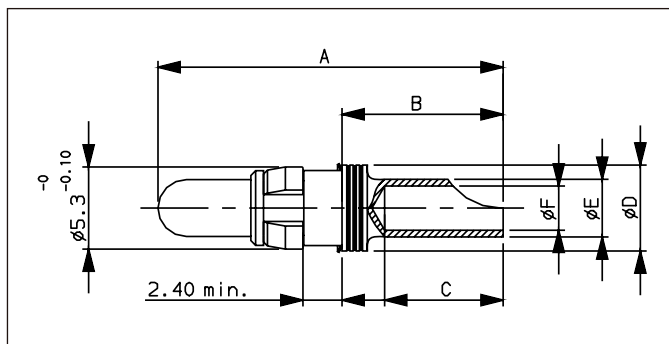

Variants 03-05

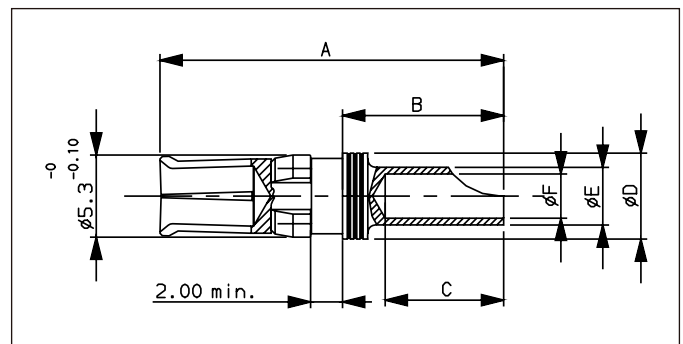

Variants 04-06

Variant	Type	A Max.	B Max.	C Max.	Ø D Max.	Ø E Max.	Ø F Max.
01	Pin	22,1 .87	10,8 .425	8,13 .32	5,66 .223	-	4,9 .193
02	Socket	21,8 .858	10,8 .425	8,13 .32	5,66 .223	-	4,9 .193
03	Pin	22,1 .87	10,8 .425	8,13 .32	5,66 .223	3,76 .148	3 .118
04	Socket	21,8 .858	10,8 .425	8,13 .32	5,66 .223	3,76 .148	3 .118
05	Pin	22,1 .87	10,8 .425	8,13 .32	5,66 .223	2,67 .105	1,9 .075
06	Socket	21,8 .858	10,8 .425	8,13 .32	5,66 .223	2,67 .105	1,9 .075

Tooling of extraction

	Part number
Extraction tool	8630-07



Power crimp contacts

Part Numbers

Version	ESA part number (Flight Models)	SOURIAU part number (Engineering Models)	Type	Wire Size (AWG)
Crimp contacts	3401 040 07B	8949 040 07NMB	Male	8
	3401 040 08B	8949 040 08NMB	Female	8
	3401 040 09B	8949 040 09NMB	Male	10
	3401 040 10B	8949 040 10NMB	Female	10
	3401 040 11B	8949 040 11NMB	Male	12-14
	3401 040 12B	8949 040 12NMB	Female	12-14

Dimensions (in mm/inch)

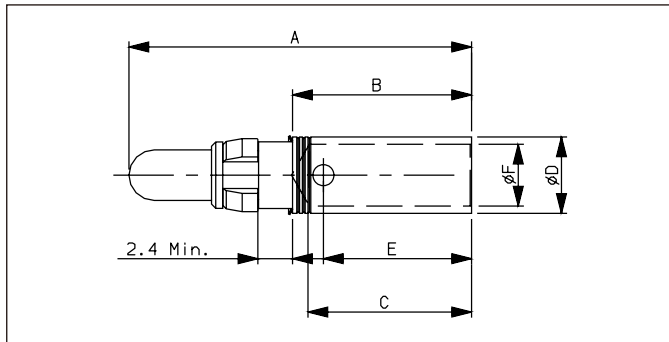

Variant 07

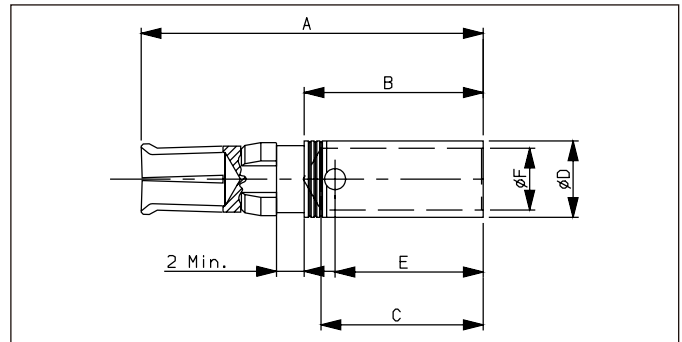

Variant 08

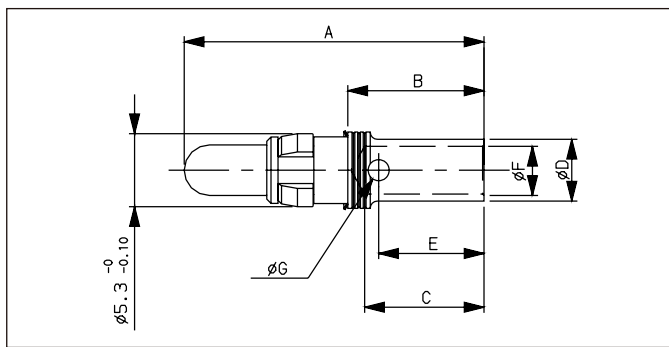

Variants 09-11

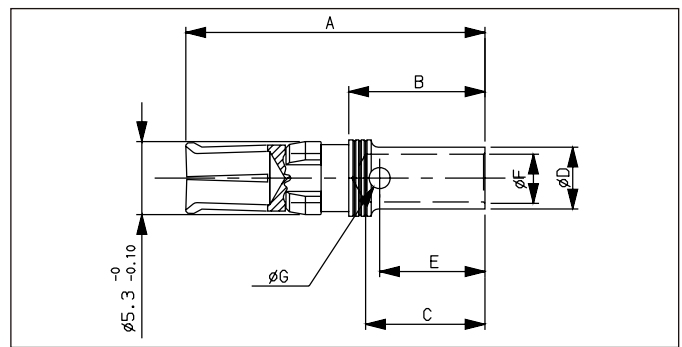

Variants 10-12

Variant	Type	A Max.	B Max.	C min	Ø D Max.	E Ref	Ø F min	Ø G Ref
07	Pin	24,7 .972	12,9 .508	11 .433	5,8 .228	10 .394	4,2 .165	1,7 .067
08	Socket	24,6 .969	12,9 .508	11 .433	5,8 .228	10 .394	4,2 .165	1,7 .067
09	Pin	21,6 .850	10 .394	8,4 .331	4,7 .185	7,5 .295	3,25 .128	1,3 .051
10	Socket	21,5 .846	10 .394	8,4 .331	4,7 .185	7,5 .295	3,25 .128	1,3 .051
11	Pin	19,3 .760	7,7 .303	6,4 .252	3,8 .15	6 .236	2,5 .098	1 .039
12	Socket	19,2 .756	7,7 .303	6,4 .252	3,8 .15	6 .236	2,5 .098	1 .039

Extraction tool

	Part number
Extraction tool	8630-07



Twinax contacts

These D-Sub Twinax contact size # 8 compatible and designed for GORE Ref. GSC-05-80583-00 A or AXON Ref. P5 12806 double braiding cable and for AXON P5 12296 single braiding cable are crimping or soldering type contacts straight or 90°, male and female.

Part Numbers

Contact type	P/N for double braiding cable		P/N for simple braiding cable	
	ESA/SCC P/N	SOURIAU P/N	ESA/SCC P/N	SOURIAU P/N
Female straight termination	3401 069 02B	8949 004 51 NMB	3401 069 06B	8949 0045 55 NMB
Male straight termination	3401 069 01B	8949 004 50 NMB	3401 069 05B	8949 0045 54 NMB
Female 90° termination	3401 069 04B	8949 004 53 NMB	3401 069 08B	8949 0045 57 NMB
Male 90° termination	3401 069 03B	8949 004 51 NMB	3401 069 07B	8949 0045 56 NMB

Dimensions (in mm)

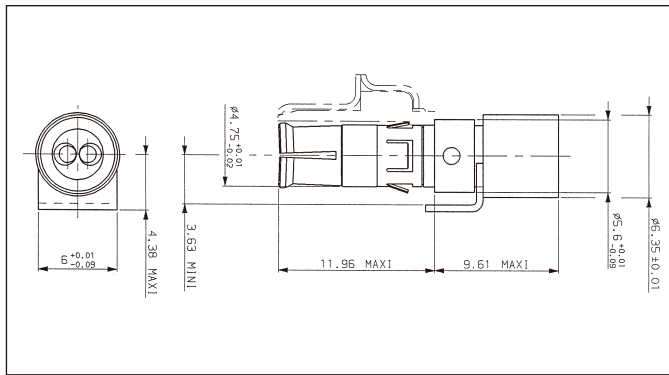

Female straight termination

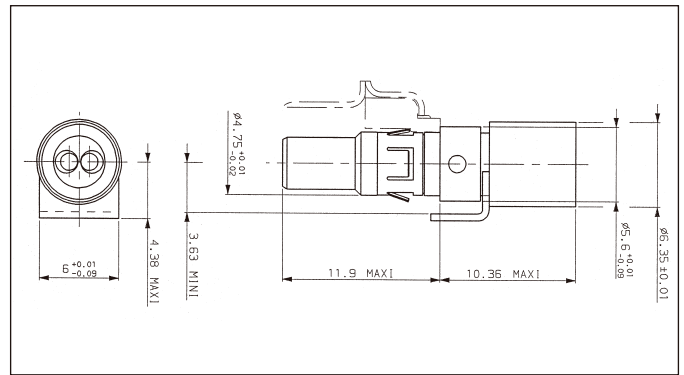

Male straight termination

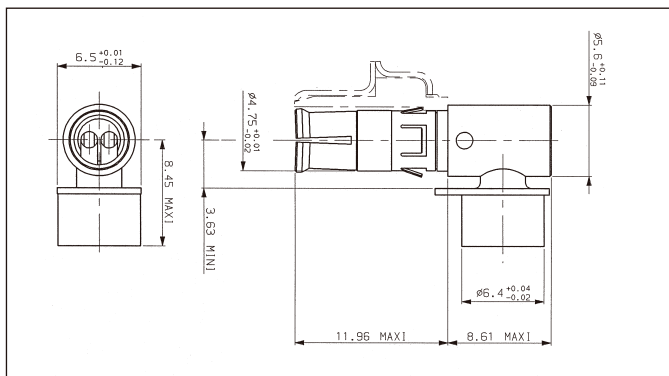

Female 90° termination

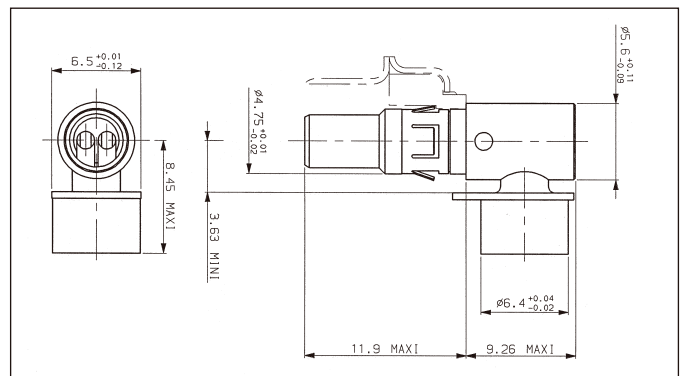

Male 90° termination

Wiring tool

	Inner pin and socket Straight termination	Inner socket 90° termination	Ext. pin and socket
Crimp tool	M 22520/2-01	Solder	M 22520/5-01
Locator	SN 1908 K 101		M 22520/5-45 Hex. B

Inner pin and socket contact Straight termination

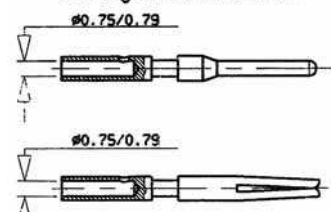

Extraction tool

	Part number
Extraction tool	8630-07A

For more wiring explanations SOURIAU document NC 8949-A-068 is available upon request to our Customer Service.

PCB Contact



Part Numbers

Contact type	P/N for twinax PCB mount.	
	ESA/SCC P/N	SOURIAU P/N
Female contact	-	8949 00458 NMB

Dimensions (in mm)

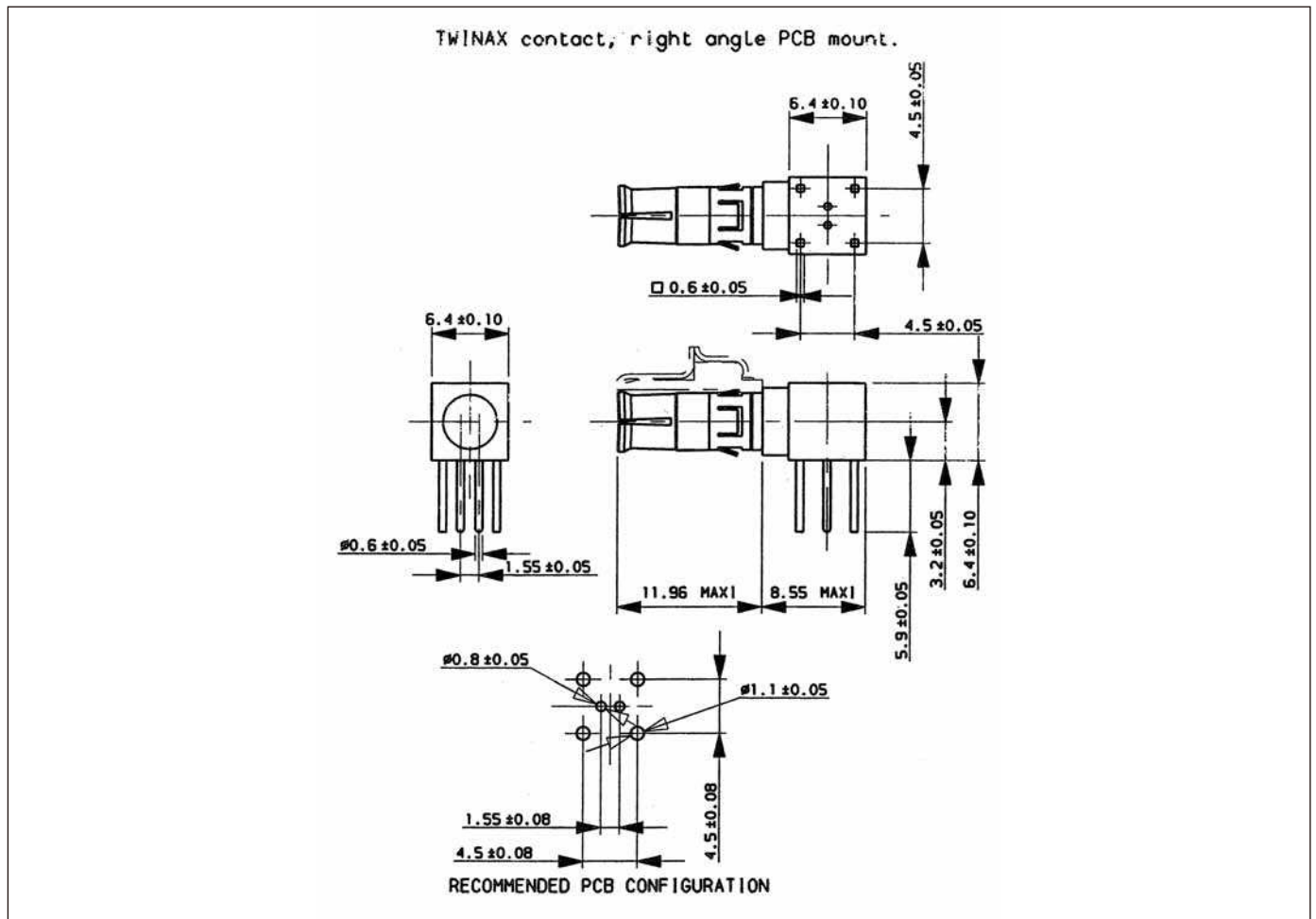

Notes



Contact # 20

Wire AWG 20/24 & 26/28*

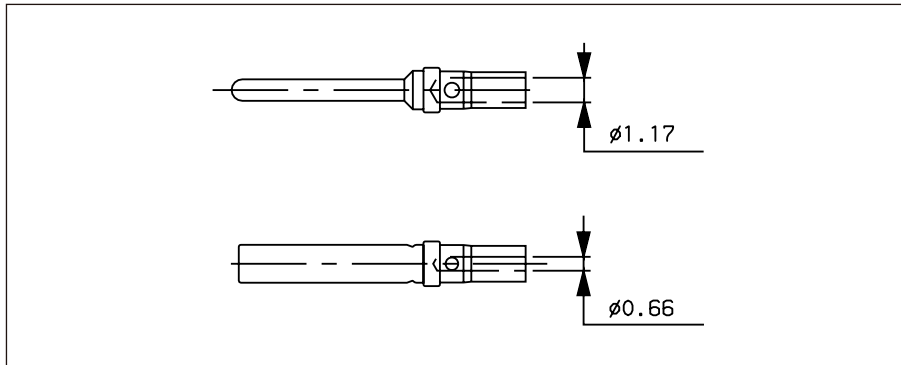

ESA part number	Souriau part number
Crimp tool	
M 22520/2-01	8476-01
Locator	
M 22520/2-08 (*) Mark n°6	8476-08

Wire AWG 18/20

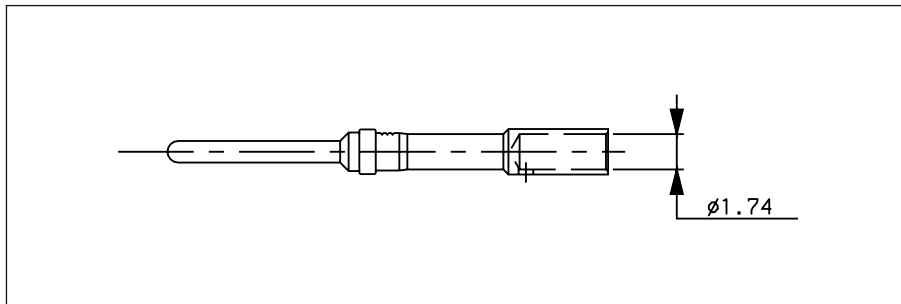

ESA part number	Souriau part number
Crimp tool	
M 22520/1-01	8365
Locator	
TP 1003	8949-1808

Contact # 22

Wire AWG 22/26

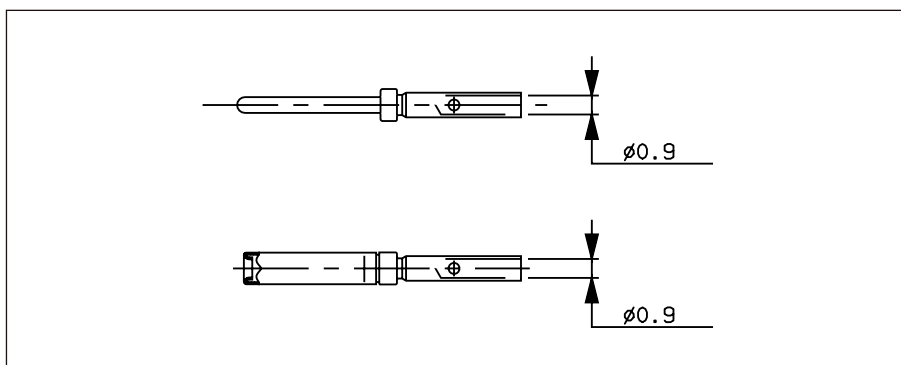

ESA part number	Souriau part number
Crimp tool	
M 22520/2-01	8476-01
Pin locator	
M 22520/2-09	8476-09
Socket locator	
M 22520/2-06	8476-06

Power contact # 8

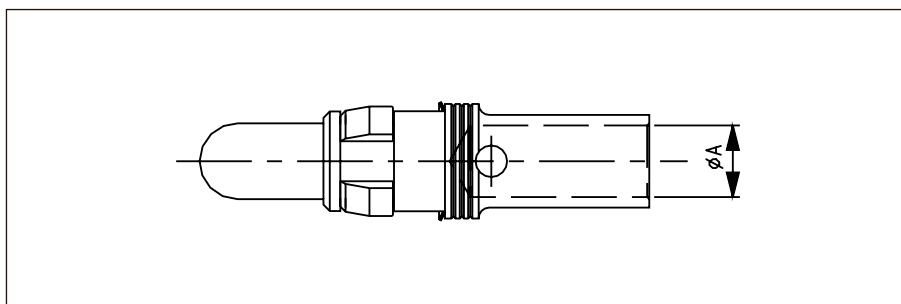

DANIELS part number	Souriau part number
Crimp tool	
M300BT	8476-200
Pin locator	
TH558	8949-1745

AWG	8	10	12/14
ϕA	4,2 1.653	3,25 .128	2,5 .098



Stripping

Coaxial contacts ESA/SCC part number		Wire type			Stripping dimensions (in mm/inch)		
Solder contact	Crimp contact	MIL-C-17	NFC 93550	ESA 3902 001	A ± 0.25	B ± 0.25	C ± 0.25
3401 004 01B	3401 004 11B	RG 178 B/U RG 196 A/U	KX 21 A		7,92 .312	6,35 .250	1,98 .078
3401 004 02B	3401 004 12B				9,52 .375	5,94 .234	1,57 .062
3401 004 03B	3401 004 13B						
3401 004 04B	3401 004 14B						
3401 004 05B	3401 004 15B	RG 179 B/U RG 316 U RG 188 A/U	KX 22 A	50 CIS	7,92 .312	6,35 .250	1,98 .078
3401 004 06B	3401 004 16B				9,52 .375	5,94 .234	1,57 .062
3401 004 07B	3401 004 17B						
3401 004 08B	3401 004 18B						
3401 004 09B	3401 004 19B	RG 180 B/U			9,52 .375	7,92 .312	1,92 .076
3401 00410B	3401 004 20B						

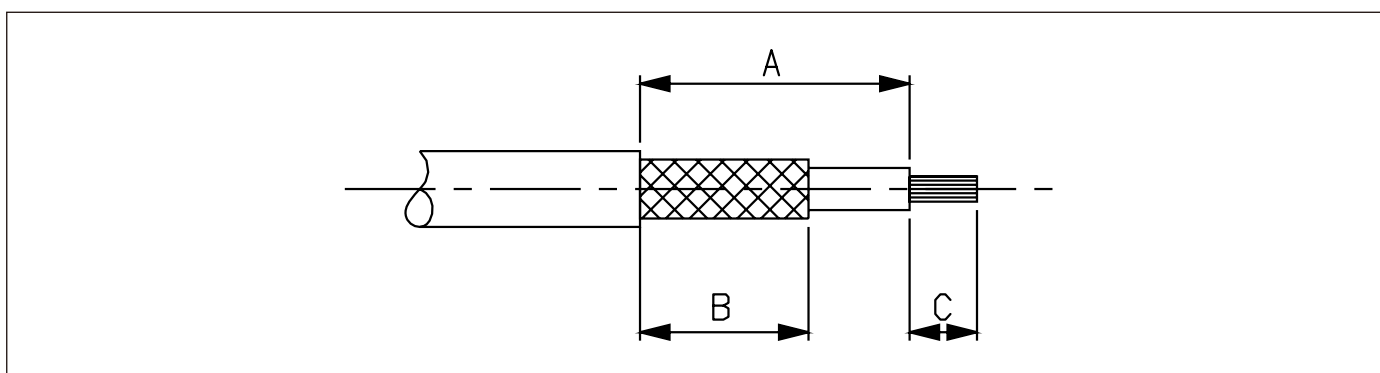

Crimping

Wire	Crimp tool	Jaws	Hex
RG 178 B/U RG 196 A/U KX 21 A	M22520/5-01	M22520/5-03	B
RG 179 B/U RG 316 U RG 188 A/U KX 22 A - 50 CIS	M22520/5-01	M22520/5-03	A
RG 180 B/U	M22520/5-01	M22520/5-43	B

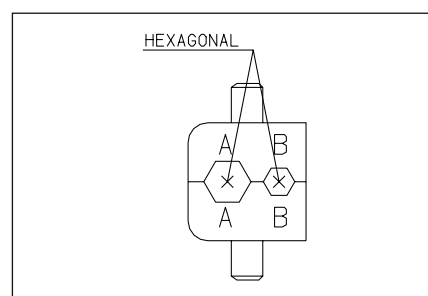

M 22520/5-01

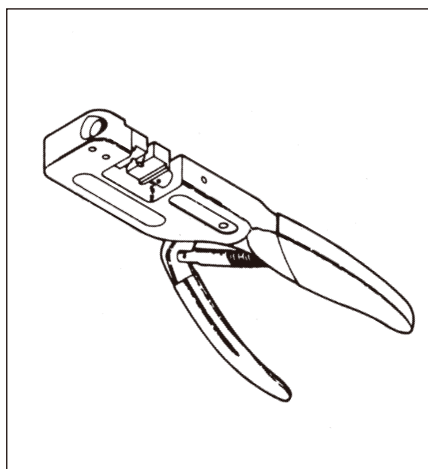



Crimp coaxial contacts

Straight outlet

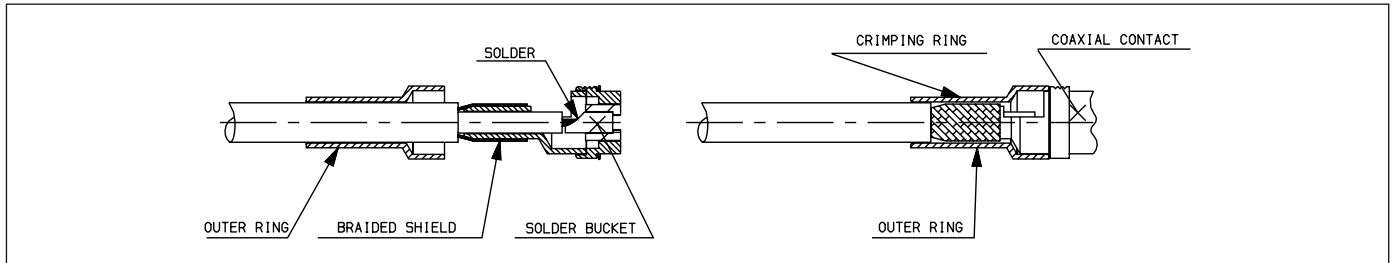

90° outlet

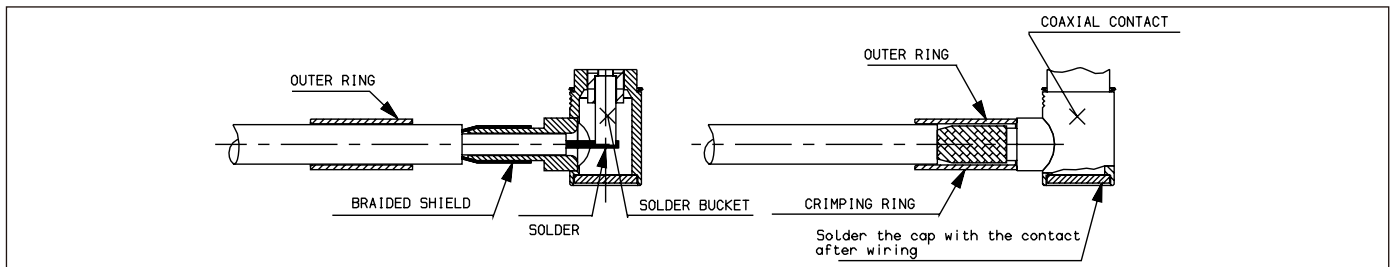

Wiring instructions

- Slide the outer ring over the cable jacket.
- Trim the cable as specified.
- Insert the cable dielectric and center conductor into the inside diameter of the inner sleeve.
- Solder the center conductor to the coax center contact.
- Cover the braided shield with the outer ring.
- Crimp with the appropriate tool.

Solder coaxial contacts

Straight outlet

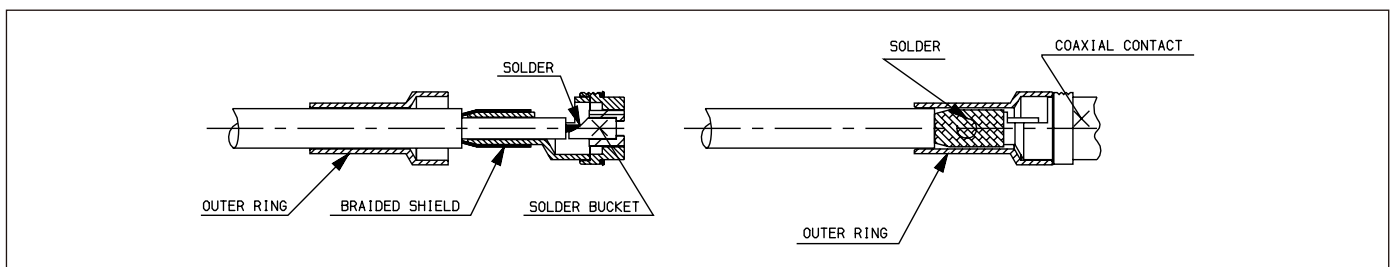

90° outlet

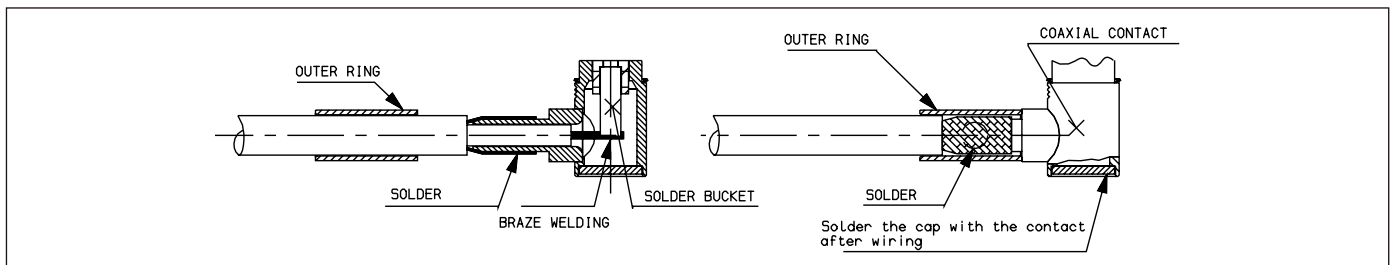

Wiring instructions

- Slide the outer ring over the cable jacket.
- Trim the cable as specified.
- Insert the cable dielectric and center conductor into the inside diameter of the inner sleeve.
- Solder the center conductor to the coax center contact.
- Place the sleeve against the shell contact.
- Solder the outer ring to the assembly through the cross-drilled solder hold.



Twinax contacts

• Straight rear-end female and male

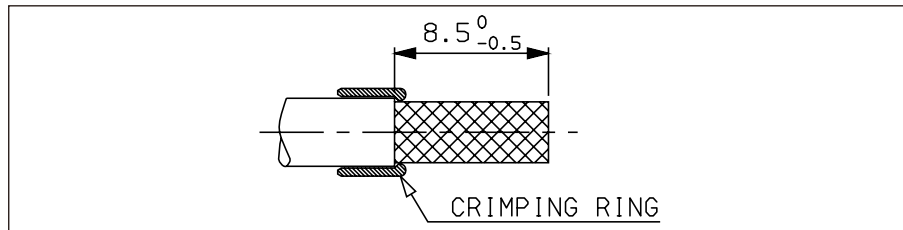

- Strip jacket at appropriate dimension
- Slide crimping ring on cable

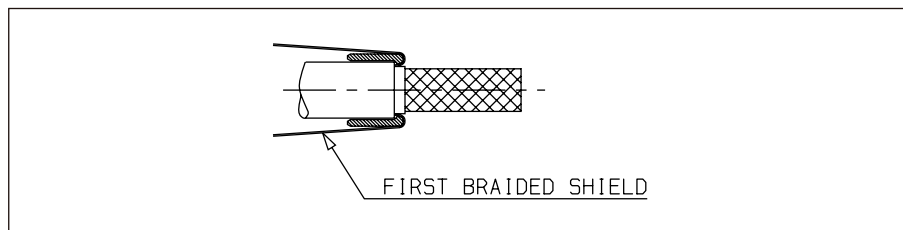

- Cover crimping ring with the first braided shield
- Strip the second braided shield

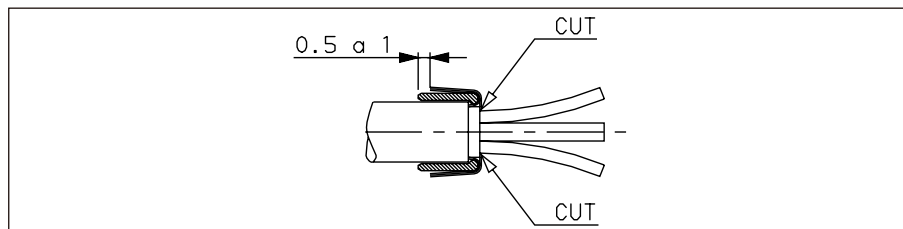

- Cover the first braided shield with the second one
- Cut the two braided shield at appropriate dimension
- Cut the filers

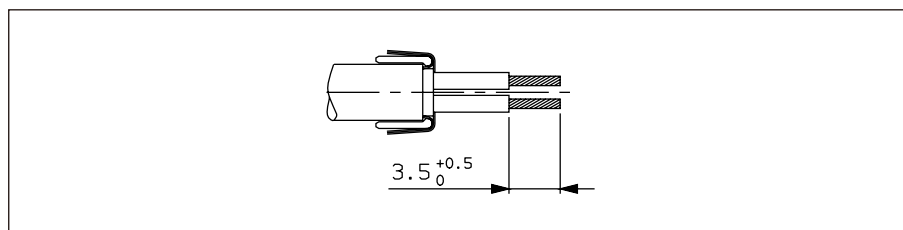

- Strip the two internal wires at appropriate dimension

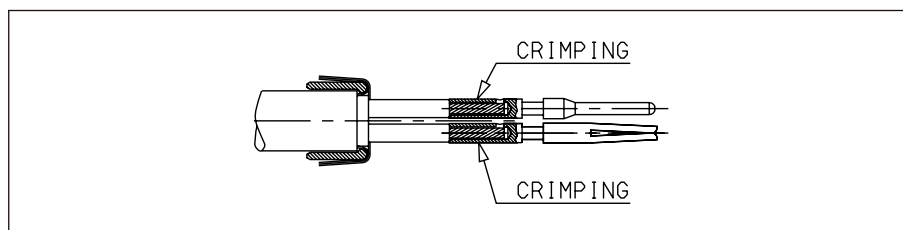

- Crimping the two signal contacts
- Used tools :
 - **Locator** : SN1908K101
 - **Crimping tool** : M22520/2-01

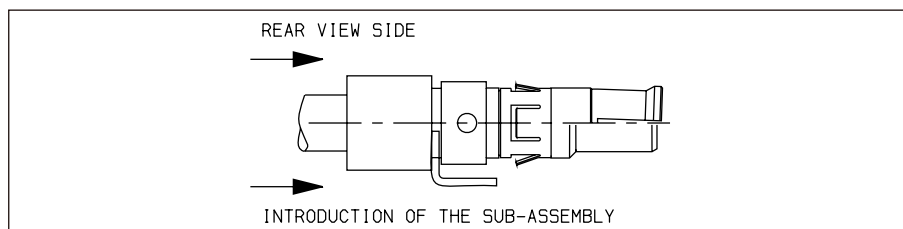

- Mount cabled sub-assembly into the external contact :
 - Blue wire on the right for female contact (rear view side)
 - Blue wire on the left for male contact (rear view side)

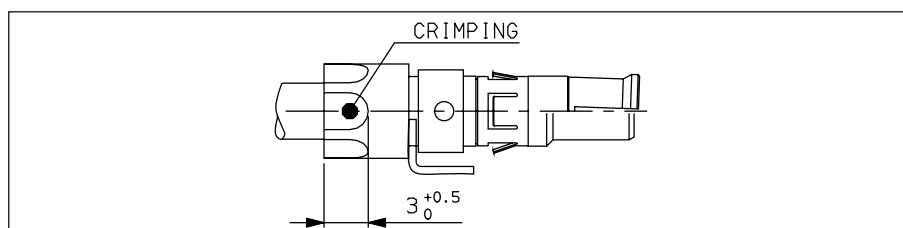

- Crimping the external contact at appropriate dimension
- Used tools :
 - **Dies** : M22520/5-45 (Mark B)
 - **Crimping tool** : M22520/5-01



Twinax contacts

• 90° rear-end female and male

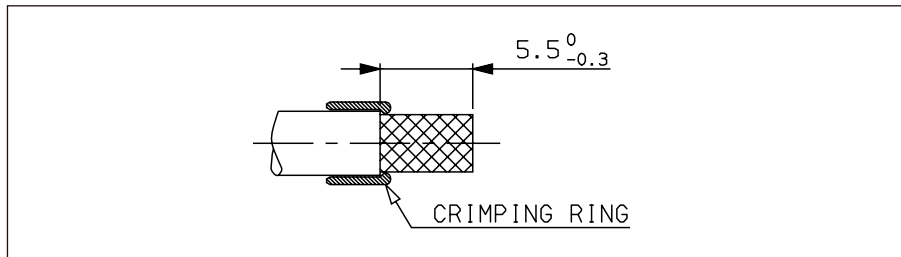

- Strip jacket at appropriate dimension
- Slide crimping ring on cable

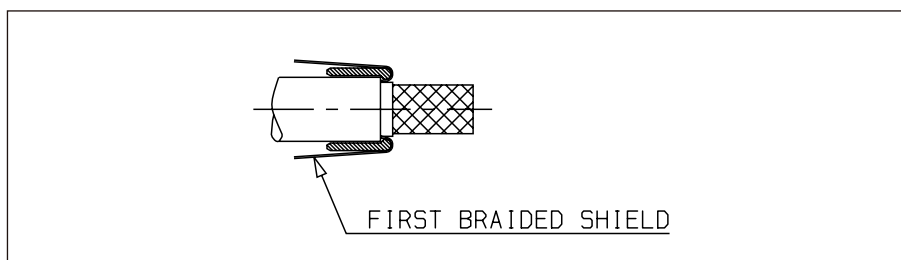

- Cover crimping ring with the first braided shield
- Strip the second braided shield

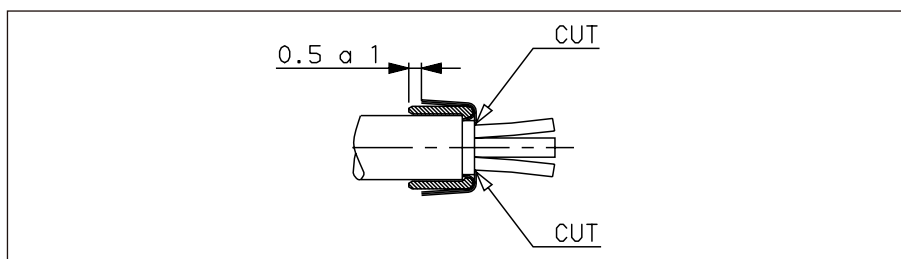

- Cover the first braided shield with the second one
- Cut the two braided shield at appropriate dimension
- Cut the filers

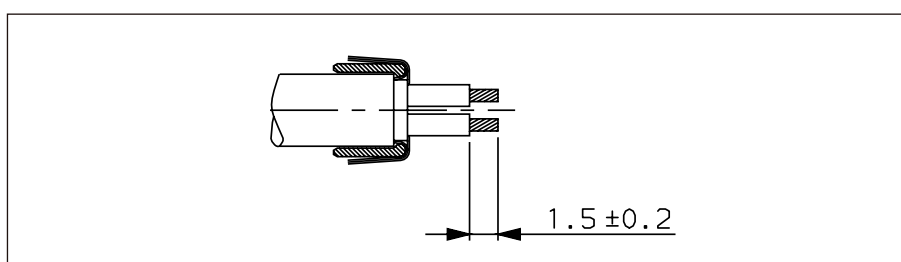

- Strip the two internal wires at appropriate dimension

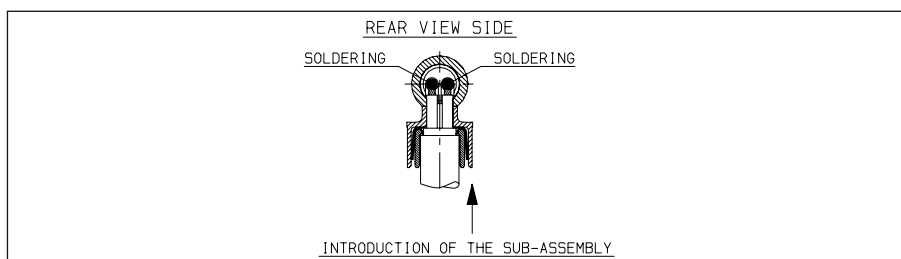

- Mount cabled sub-assembly into the external contact :
 - Blue wire on the right for female contact (rear view side)
 - Blue wire on the left for male contact (rear view side)
- Solder the two conductors to the two contacts using appropriate solder iron

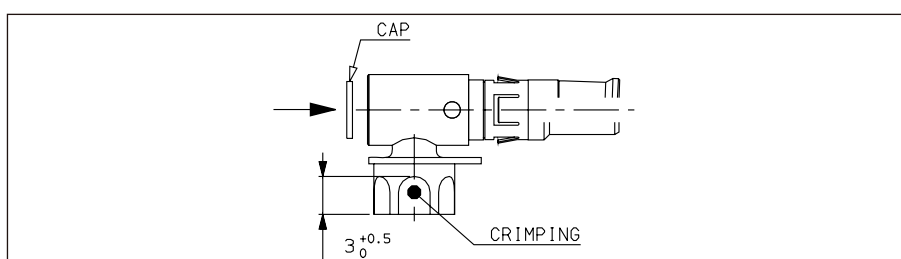

- Crimping the external contact at appropriate dimension
- Used tools :
 - **Dies** : M22520/5-45 (Mark B)
 - **Crimping tool** : M22520/5-01
- Fit the cap and solder it

ESA/SCC 3401 022 & Space grade



Male screw lock

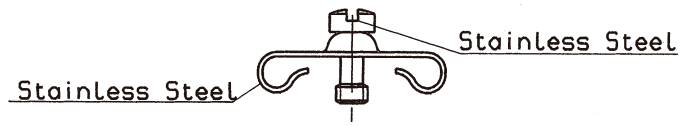
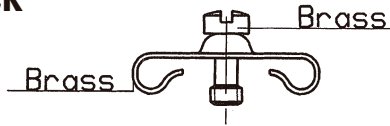

	Shell size	ESA/SCC P/N	SOURIAU P/N
WITHOUT BACKSHELL	B, C : S E, A : P, S	3401 022 02BNMB	D8949 P102 NM
	B, C : P	3401 022 03BNMB	D8949 P103 NM
	D : S	3401 022 04BNMB	D8949 P104 NM
	D : P	3401 022 05BNMB	D8949 P105 NM

	Shell size	ESA/SCC P/N	SOURIAU P/N
WITHOUT BACKSHELL	B, C : S E, A : P, S	3401 022 49B	D8949 P149 NM
	B, C : P	3401 022 50B	D8949 P150 NM
	D : S	3401 022 51B	D8949 P151 NM
	D : P	3401 022 52B	D8949 P152 NM

	Shell size	ESA/SCC P/N	SOURIAU P/N
WITH BACKSHELL	B, C : S E, A : P, S	3401 022 44BNMB	D8949 P144 NM
	B, C : P	3401 022 45BNMB	D8949 P145 NM
	D : S	3401 022 45BNMB	D8949 P146 NM
	D : P	3401 022 47BNMB	D8949 P147 NM

	Shell size	ESA/SCC P/N	SOURIAU P/N
WITH BACKSHELL	B, C : S E, A : P, S	3401 022 54B	D8949 P154 NM
	B, C : P	3401 022 55B	D8949 P155 NM
	D : S	3401 022 56B	D8949 P156 NM
	D : P	3401 022 57B	D8949 P157 NM

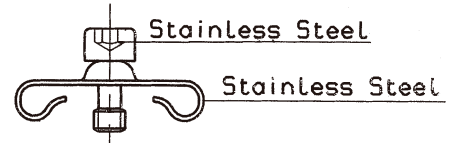
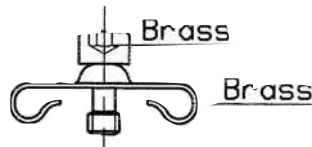

	Shell size	ESA/SCC P/N	SOURIAU P/N
WITHOUT BACKSHELL	B, C : S E, A : P, S	3401 022 65BNMB	D8949 P165 NM
	B, C : P	3401 022 66BNMB	D8949 P166 NM
	D : S	3401 022 67BNMB	D8949 P167 NM
	D : P	3401 022 68BNMB	D8949 P168 NM

	Shell size	ESA/SCC P/N	SOURIAU P/N
WITHOUT BACKSHELL	B, C : S E, A : P, S	3401 022 73B	D8949 P349 NM
	B, C : P	3401 022 74B	D8949 P350 NM
	D : S	3401 022 75B	D8949 P351 NM
	D : P	3401 022 76B	D8949 P352 NM

	Shell size	ESA/SCC P/N	SOURIAU P/N
WITH BACKSHELL	B, C : S E, A : P, S	3401 022 69BNMB	D8949 P265 NM
	B, C : P	3401 022 70BNMB	D8949 P266 NM
	D : S	3401 022 71BNMB	D8949 P267 NM
	D : P	3401 022 72BNMB	D8949 P268 NM

	Shell size	ESA/SCC P/N	SOURIAU P/N
WITH BACKSHELL	B, C : S E, A : P, S	3401 022 77B	D8949 P354 NM
	B, C : P	3401 022 78B	D8949 P355 NM
	D : S	3401 022 79B	D8949 P356 NM
	D : P	3401 022 80B	D8949 P357 NM

Dimensions (in mm/inch)

Use with shell size	N		Q		R		S
	min	Max.	min	Max.	min	Max.	
Without backshell							
A, E : (P or S) B, C : S	12.96	13.72	3.22	3.98	0.75	0.95	2.80 mini
B, C : P	12.96	13.72	3.22	3.98	0.95	1.15	2.80 mini
D : S	15.75	16.26	3.22	3.98	0.95	0.95	2.80 mini
D : P	15.75	16.26	3.22	3.98	0.95	1.15	2.80 mini
With backshell							
A, E : (P or S) B, C : S	12.96	13.72	4.22	4.98	0.75	1.95	2.80 mini
B, C : P	12.96	13.72	4.22	4.98	0.95	2.20	2.80 mini
D : S	15.75	16.26	4.22	4.98	0.95	1.95	2.80 mini
D : P	15.75	16.26	4.22	4.98	0.95	2.20	2.80 mini

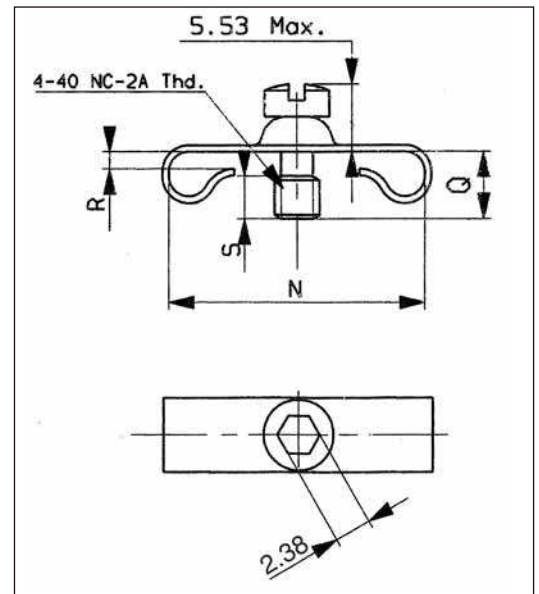



ESA/SCC 3401 022 & Space grade

Female screw lock

Part Number

ESA/SCC 3401 022 (Flight models)

NM : Space Grade (Engineering models)

ESA/SCC P/N		Materials	SOURIAU P/N	
Standard	3401 022 01BNMB		Brass	Standard
For savers	3401 022 06BNMB	For savers		D8949 S61 NM
Standard	3401 022 48B	Stainless steel	Standard	D8949 S70 NM
For savers	3401 022 53B		For savers	D8949 S71 NM

Dimensions (in mm/inch)

Variant	H		J		K	
	min	Max.	min	Max.	min	Max.
01 & 48	4,37 .172	5,13 .202	7,54 .297	8,3 .327	4,6 .181	5,1 .201
06 & 53	4,37 .172	5,13 .202	14,35 .565	14,65 .577	4,6 .181	5,1 .201

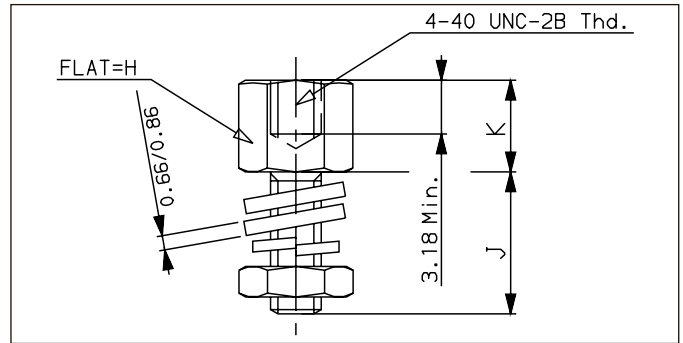

Male screw lock assemblies for lightweight back shell

Use with shell size with lightweight back shell		ESA/SCC P/N	SOURIAU P/N
E to C : (P or S)	Brass	3401 072 01BNMB	D8949 P112 NM
	Stainless steel	3401 072 03B	D8949 P114 NM
D : (P or S)	Brass	3401 072 02BNMB	D8949 P113 NM
	Stainless steel	3401 072 04B	D8949 P115 NM

Use with shell size with lightweight back shell	N		Q		R		S
	min	Max.	min	Max.	min	Max.	
E to C : (P or S)	12.96	13.72	4.40	5.16	2.25	2.45	2.80 mini
E : (P or S)	15.75	16.26	4.40	5.16	2.25	2.45	2.80 mini





ESA/SCC 3401 022 & Space grade

Dust cap

Part Number

ESA/SCC 3401 022 (Flight models)

Shell size	For male connectors	For female connectors
E	3401 022 08B	3401 022 07B
A	3401 022 10B	3401 022 09B
B	3401 022 12B	3401 022 11B
C	3401 022 14B	3401 022 13B
D	3401 022 16B	3401 022 15B

NM : Space Grade (Engineering models)

Shell size	For male connectors	For female connectors
E	70508	70513
A	70509	70514
B	70510	70515
C	70511	70516
D	70512	70517

Dimensions (in mm/inch)

Shell size	Male connectors		Female connectors	
	A	B	A	B
E	19,2 .756	10,3 .406	17,8 .701	9 .354
A	27,5 1.083	10,3 .406	26,1 1.028	9 .354
B	41,7 1.642	10,7 .421	39,8 1.567	9 .354
C	58,1 2.287	10,7 .421	56,3 2.217	9 .354
D	55,5 2.185	13,4 .528	53,9 2.122	11,9 .469

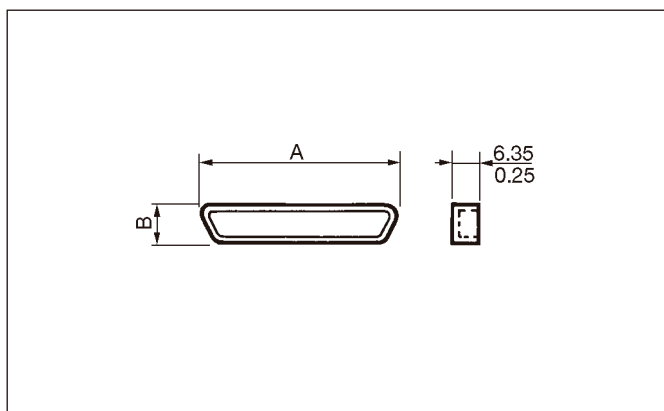

ESA/SCC 3401 072 & Space Grade



Lightweight design with saddle clamps for strain relief

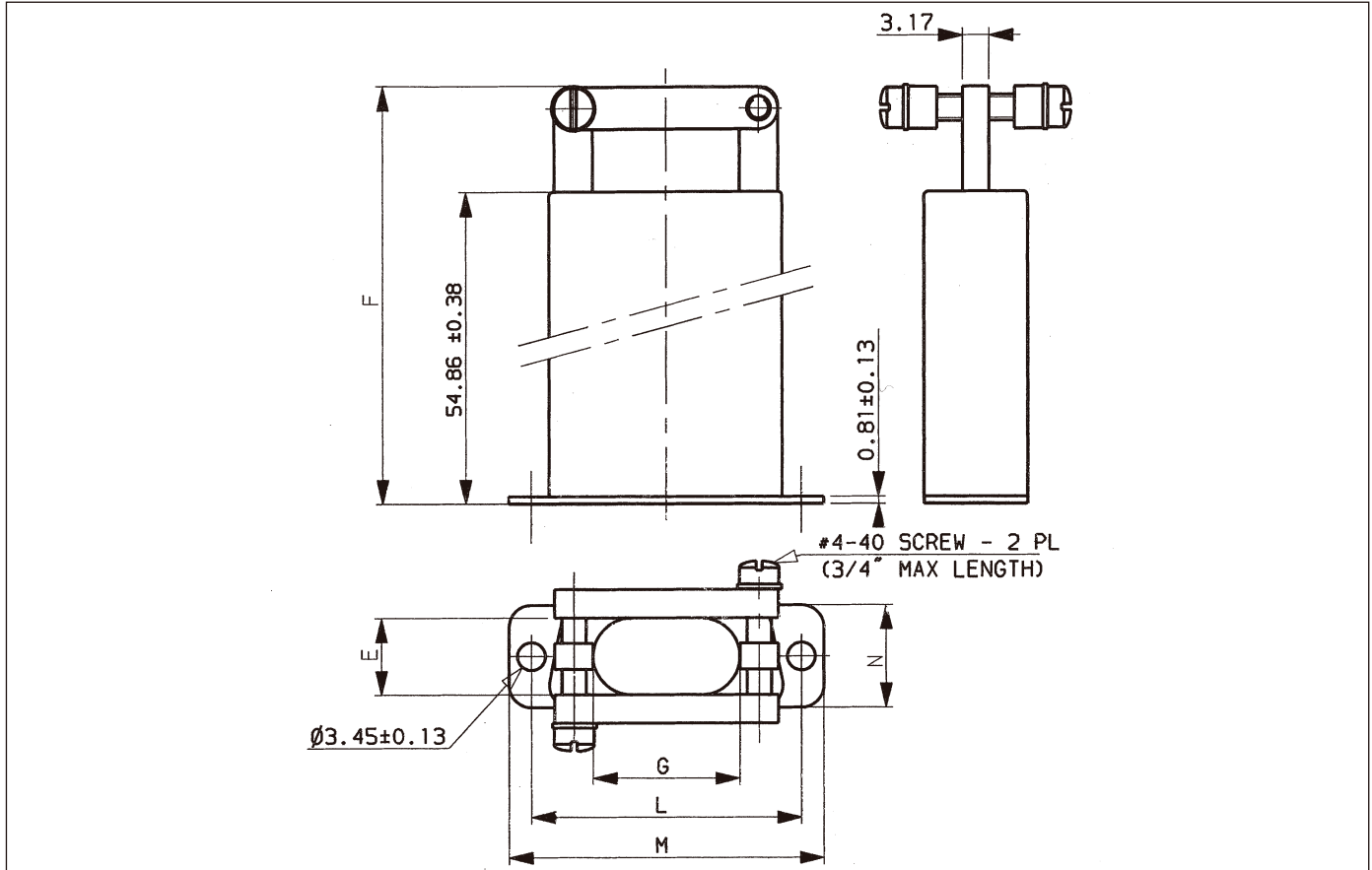

Shell size	E±0,38	F±0,60	G±0,38	M±0,38	N±0,14	L±0,25	ESA/SCC P/M	SOURIAU P/N
E	9,52	67,56	8,89	30,56	13,05	24,99	3401 072 05B NMB	DE 8949 014 NMB
A	9,52	67,56	12,06	38,89	13,05	33,32	3401 072 06B NMB	DA 8949 014 NMB
B	9,52	69,16	12,70	52,78	13,05	47,04	3401 072 07B NMB	DB 8949 014 NMB
C	9,52	69,16	12,70	69,04	13,05	63,50	3401 072 08B NMB	DC 8949 014 NMB
D	11,88	69,16	15,46	66,67	15,82	61,11	3401 072 09B NMB	DD 8949 014 NMB

Lightweight D-Sub shorting can

Shell size	M±0,38	N±0,38	L±0,25	ESA/SCC P/M	SOURIAU P/N
E	30,56	12,70	24,99	3401 072 10B NMB	DE 8949 301 NMB
A	38,89	12,70	33,32	3401 072 11B NMB	DA 8949 301 NMB
B	52,78	12,70	47,04	3401 072 12B NMB	DB 8949 301 NMB
C	69,04	12,70	63,50	3401 072 13B NMB	DC 8949 301 NMB
D	66,67	15,47	61,11	3401 072 14B NMB	DD 8949 301 NMB

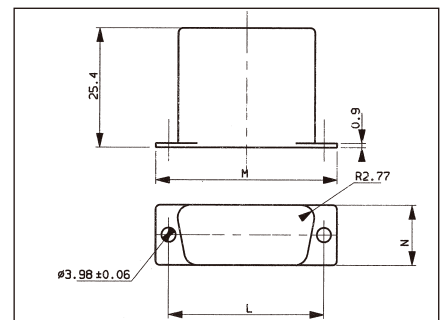

ESA/SCC 3401 072 & Space Grade



EMI shielded backshell-straight cable outlet

Shell size	ESA/SCC P/N Front/mount	SOURIAU P/N Front/mount	Ø G±0,25	M±0,25	L±0,25	R±0,13	
						Front/mount	
E	3401 072 15B NMB	DE 8949 405 1NMB	6,73	15,98	35,03	7,74	
A	3401 072 16B NMB	DA 8949 405 1NMB	9,90	15,98	43,36	7,74	
B	3401 072 17B NMB	DB 8949 405 1NMB	10,54	15,98	57,25	7,74	
C	3401 072 18B NMB	DC 8949 405 1NMB	10,54	15,98	73,53	7,74	
D	3401 072 19B NMB	DD 8949 405 1NMB	13,33	18,79	71,14	7,74	

Shell size	ESA/SCC P/N Rear/mount	SOURIAU P/N Rear/mount	Ø G±0,25	M±0,25	L±0,25	R±0,13	
						Rear/mount	
E	3401 072 20B NMB	DE 8949 405 2NMB	6,73	15,98	35,03		6,32
A	3401 072 21B NMB	DA 8949 405 2NMB	9,90	15,98	43,36		6,32
B	3401 072 22B NMB	DB 8949 405 2NMB	10,54	15,98	57,25		6,32
C	3401 072 23B NMB	DC 8949 405 2NMB	10,54	15,98	73,53		6,32
D	3401 072 24B NMB	DD 8949 405 2NMB	13,33	18,79	71,14		6,32

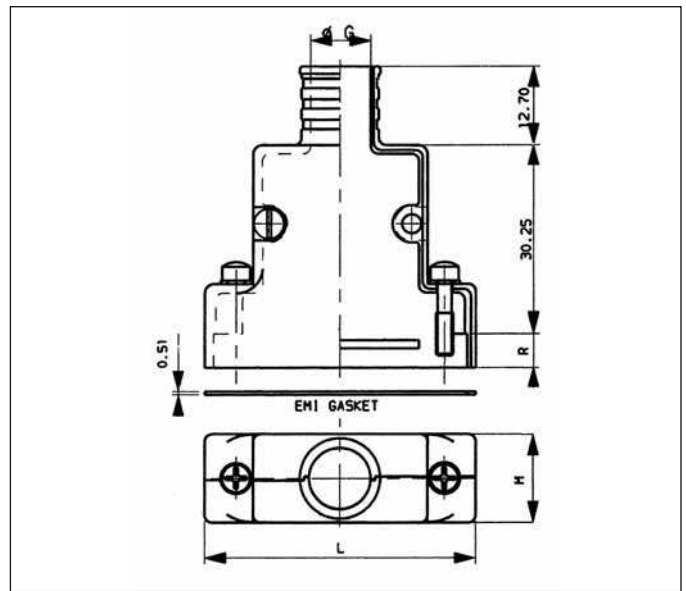
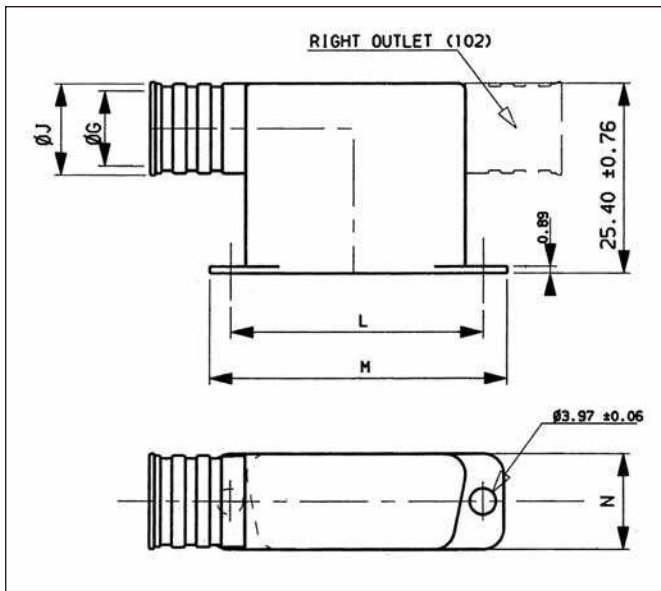

Light shielded backshell-90° longitudinal cable outlet

Shell size	Right outlet		Ø G±0,25	J±0,38	M±0,36	N±0,38	L±0,13
	ESA/SCC P/N	SOURIAU P/N					
E	3401 072 25B NMB	DE 8949 102K NMB	6,85	8,89	30,56	12,70	24,99
A	3401 072 26B NMB	DA 8949 102E NMB	10,03	12,06	38,89	12,70	33,32
B	3401 072 27B NMB	DB 8949 102F NMB	10,66	12,70	52,78	12,70	47,04
C	3401 072 28B NMB	DC 8949 102F NMB	10,66	12,70	69,04	12,70	63,50
D	3401 072 29B NMB	DD 8949 102H NMB	13,43	15,46	66,67	15,47	61,11

Shell size	Left outlet		Ø G±0,25	J±0,38	M±0,36	N±0,38	L±0,13
	ESA/SCC P/N	SOURIAU P/N					
E	3401 072 30B NMB	DE 8949 101K NMB	6,85	8,89	30,56	12,70	24,99
A	3401 072 31B NMB	DA 8949 101E NMB	10,03	12,06	38,89	12,70	33,32
B	3401 072 32B NMB	DB 8949 101F NMB	10,66	12,70	52,78	12,70	47,04
C	3401 072 33B NMB	DC 8949 101F NMB	10,66	12,70	69,04	12,70	63,50
D	3401 072 34B NMB	DD 8949 101H NMB	13,43	15,46	66,67	15,47	61,11

ESA/SCC 3401 072 & Space Grade



Lightweight shielded backshell-straight cable outlet

Shell size	ESA/SCC P/N	SOURIAU P/N	$\varnothing G \pm 0,25$	$J \pm 0,38$	$M \pm 0,38$	$N \pm 0,38$	$L \pm 0,13$
E	3401 072 35B NMB	DE 8949 001 NMB	6,85	8,89	30,56	12,70	24,99
A	3401 072 36B NMB	DA 8949 001 NMB	10,03	12,06	38,89	12,70	33,32
B	3401 072 37B NMB	DB 8949 001 NMB	10,66	12,70	52,78	12,70	47,04
C	3401 072 38B NMB	DC 8949 001 NMB	10,66	12,70	69,04	12,70	63,50
D	3401 072 39B NMB	DD 8949 001 NMB	13,43	15,46	66,67	15,47	61,11

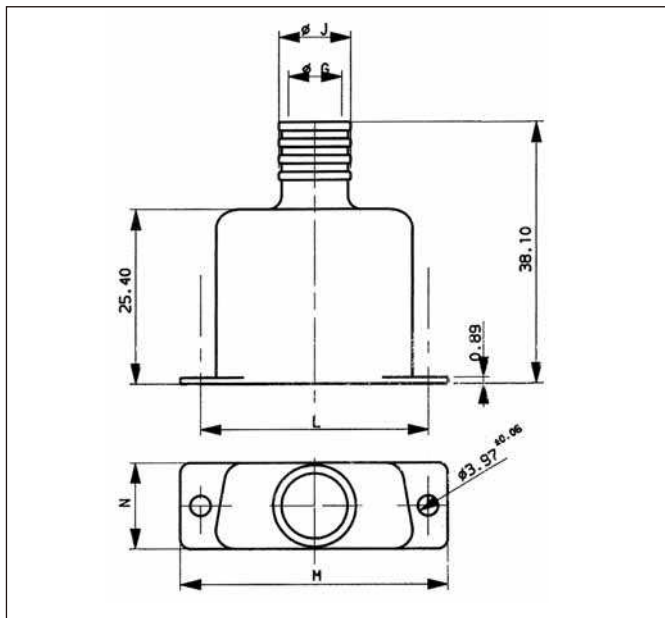

Lightweight backshell dual entry band termination, 15 pin

Shell size	ESA/SCC P/N	SOURIAU P/N
A	3401 072 40B NMB	DA 8949 020 NMB

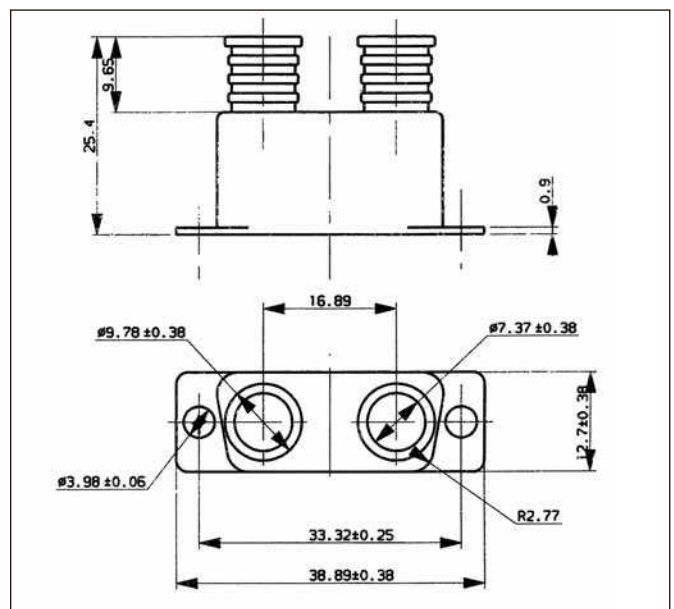

ESA/SCC 3401 072 & Space Grade



Straight lightweight backshell ultra elliptical band-termination

Shell size	ESA SCC P/N	SOURIAU P/N	A±0,38	B±0,38	C±0,13	D±0,38
E	3401 072 46B NMB	DE 8949 009A-1 NMB	30,56	12,70	24,99	12,70
A	3401 072 47B NMB	DA 8949 009B-1 NMB	38,89	12,70	33,32	15,87
B	3401 072 48B NMB	DB 8949 009C-1 NMB	52,78	12,70	47,04	19,05
C	3401 072 49B NMB	DC 8949 009E-1 NMB	69,04	12,70	63,50	25,40
D	3401 072 50B NMB	DD 8949 009D-1 NMB	66,67	15,46	61,11	22,22

45° lightweight backshell ultra elliptical band-termination

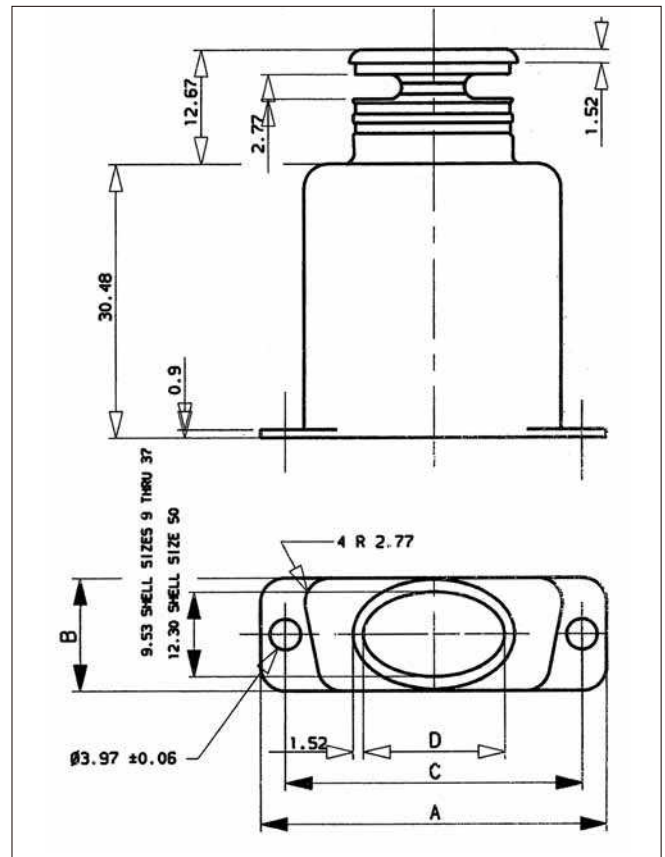
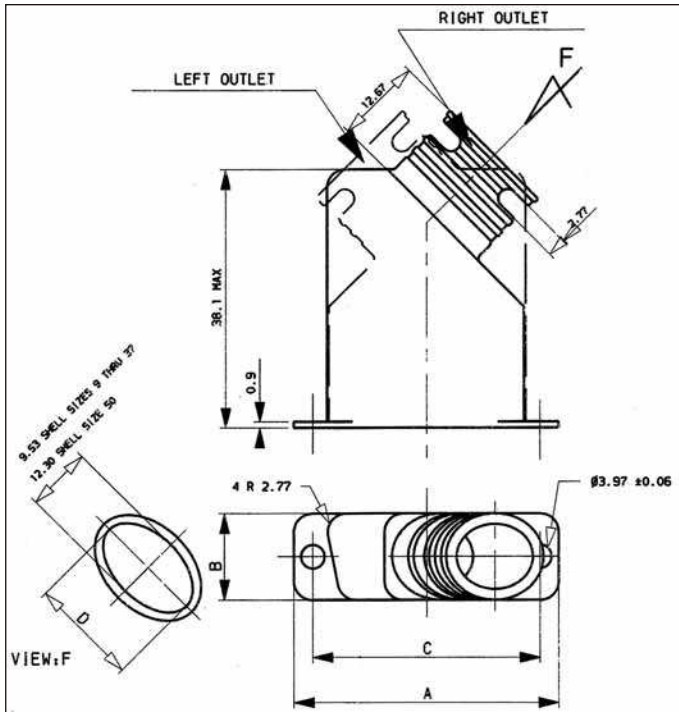

Shell size	Right outlet		A±0,38	B±0,38	C±0,13	D±0,38
	ESA SCC P/N	SOURIAU P/N				
E	3401 072 51B NMB	DE 8949 107A-1 NMB	30,56	12,70	24,99	12,70
A	3401 072 52B NMB	DA 8949 107B-1 NMB	38,89	12,70	33,32	15,87
B	3401 072 53B NMB	DB 8949 107C-1 NMB	52,78	12,70	47,04	19,05
C	3401 072 54B NMB	DC 8949 107E-1 NMB	69,04	12,70	63,50	25,40
D	3401 072 55B NMB	DD 8949 107D-1 NMB	66,67	15,46	61,11	22,22

Shell size	Left outlet		A±0,38	B±0,38	C±0,13	D±0,38
	ESA SCC P/N	SOURIAU P/N				
E	3401 072 56B NMB	DE 8949 108A-1 NMB	30,56	12,70	24,99	12,70
A	3401 072 57B NMB	DA 8949 108B-1 NMB	38,89	12,70	33,32	15,87
B	3401 072 58B NMB	DB 8949 108C-1 NMB	52,78	12,70	47,04	19,05
C	3401 072 59B NMB	DC 8949 108E-1 NMB	69,04	12,70	63,50	25,40
D	3401 072 60B NMB	DD 8949 108D-1 NMB	66,67	15,46	61,11	22,22

ESA/SCC 3401 072 & Space Grade



Lightweight D-SUB extra-shorting can

Shell size	ESA/SCC P/N	SOURIAU P/N	M±0,38	N±0,38	L±0,25
E	3401 072 61B NMB	DE 8949 305 NMB	30,56	12,70	24,99
A	3401 072 62B NMB	DA 8949 305 NMB	38,89	12,70	33,32
B	3401 072 63B NMB	DB 8949 305 NMB	52,78	12,70	47,04
C	3401 072 64B NMB	DC 8949 305 NMB	69,04	12,70	63,50
D	3401 072 65B NMB	DD 8949 305 NMB	66,67	15,47	61,11

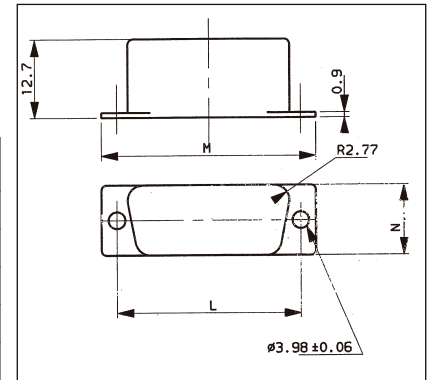

Castellated backshell

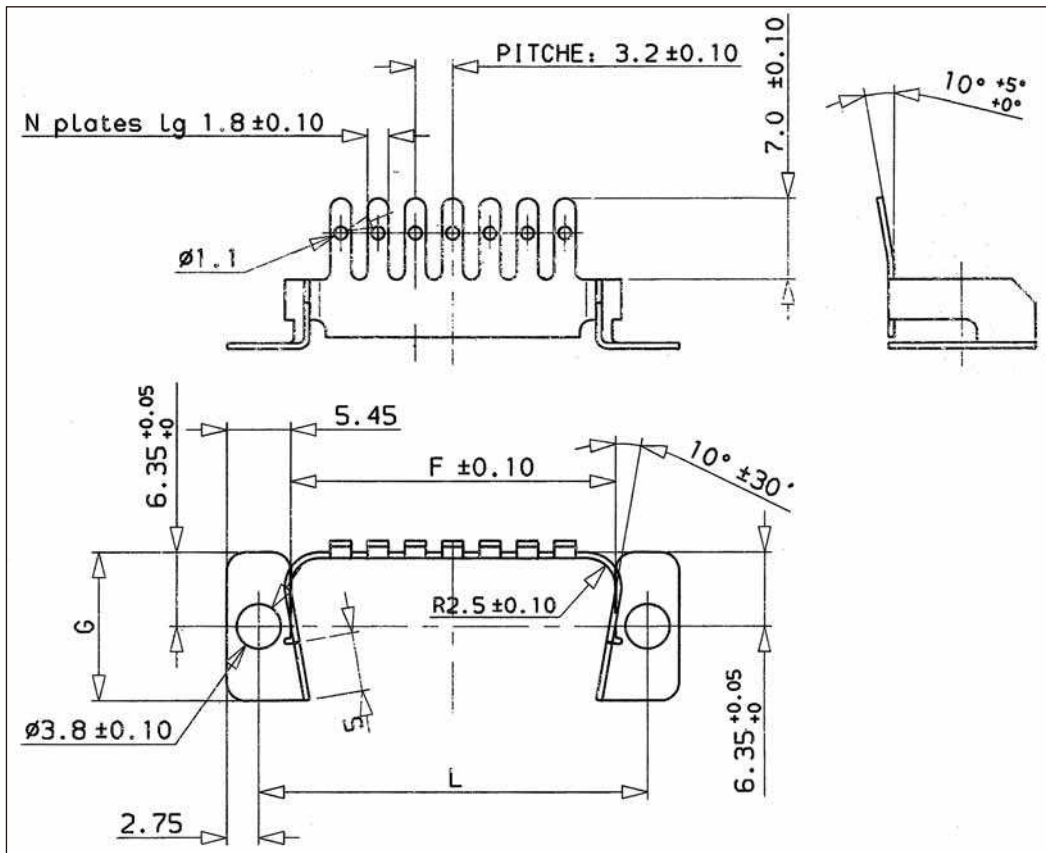

Shell size	SOURIAU P/N		F±0,10	G±0,10	L±0,13	N
	Silver plating	Gold plating				
E	DE 8949 XH NMS	DE 8949 XH NMB	19,60	12,70	24,99	5
A	DA 8949 XH NMS	DA 8949 XH NMB	27,85	12,70	33,32	7
B	DB 8949 XH NMS	DB 8949 XH NMB	41,50	12,70	47,04	11
C	DC 8949 XH NMS	DC 8949 XH NMB	58,10	12,70	63,50	16
D	DD 8949 XH NMS	DD 8949 XH NMB	55,75	15,40	61,11	15



Lightweight shielded backshells - 45° & 90° Longitudinal cable outlets

Accessories	D	E	8949	101	K	1	NM	J
Shell size E - A - B - C - D								
Cable outlet option								
45° cable outlet	105 : left							
	106 : right							
90° cable outlet	101 : left							
	102 : right							
Cable outlet type (see below ★)								
Height code (only for 90° outlet)								
	mm	inch						
Blank	25,40	1,00						
- 1	31,75	1,25						
- 2	38,10	1,50						
- 3	44,45	1,75						
- 4	50,80	2,00						
Non magnetic								
Finish code								
B	: 0,8 µm gold							
J	: 12,7 µm nickel (per MIL-C-26074 grade B)							

Characteristics

- For use with MIL-DTL-24308 connectors space or MIL-C grade
- Solid fully machined aluminium alloy
- Cable outlet for banded clamp termination system
- 45° and 90° longitudinal cable outlet various type by shell (left or right)
- Non magnetic D-Sub backshells

45° longitudinal cable outlet

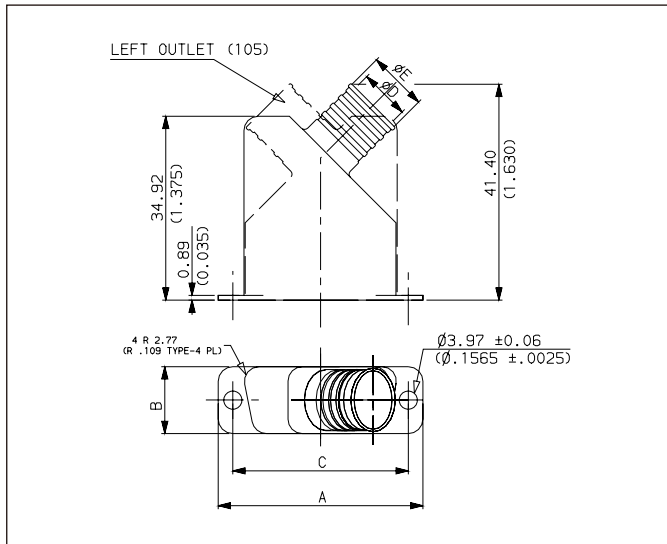

90° longitudinal cable outlet

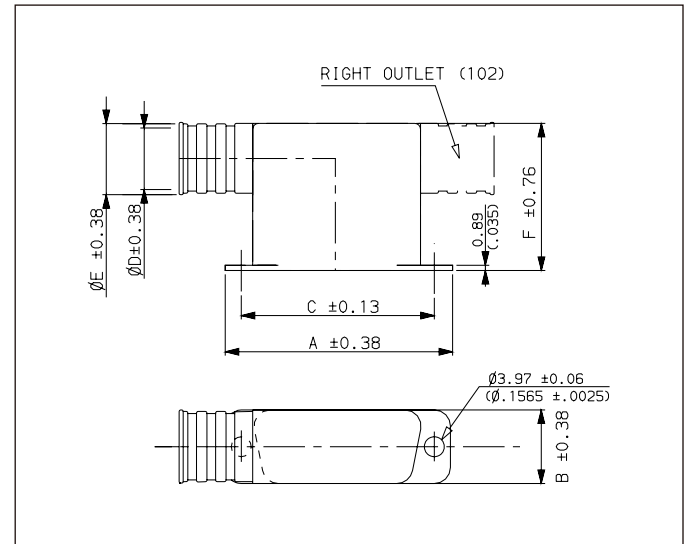

Shell size	A	B	C	Standard cable outlet size			Specific cable outlet size		
				Ø D	Ø E	★ Outlet type	Ø D	Ø E	★ Outlet type
E	30,56 .1203	12,7 .500	24,99 .984	6,86 .270	8,89 .350	K	3,17 .125	5,21 .205	A
A	38,89 .1531	12,7 .500	33,32 .1312	10,03 .395	12,06 .475	E	4,75 .187	6,78 .267	B
B	52,78 .2078	12,7 .500	47,04 .1852	10,66 .420	12,7 .500	F	7,92 .312	9,96 .392	D
C	69,04 .2718	12,7 .500	63,5 .2500	10,66 .420	12,7 .500	F	7,92 .312	9,96 .392	D
D	66,67 .2625	15,47 .609	61,11 .2406	13,43 .529	15,46 .609	H	10,03 .395	12,06 .475	E



EMI/RFI Shielded backshells Straight & Low profile outlet banded clamp termination

Accessories	D	E	8949	405	K	1	NM	J
Shell size E - A - B - C - D								
Cable outlet option								
Straight outlet	405							
Low profile outlet	401							
Cable outlet type (only for low profile outlet) (see below ★)								
Height code								
Front mount	Rear mount	mm	inch					
1	-	7,74	0.305					
-	2	6,32	0.249					
-	3	5,53	0.218					
-	4	4,74	0.187					
-	5	3,93	0.155					
Non magnetic								
Finish code								
B	: 0,8 µm gold							
J	: 12,7 µm nickel (per MIL-C-26074 grade B)							

Characteristics

- Solid fully machined aluminium alloy
- Cable outlet for banded clamp termination system
- For front or rear mount with EMI gasket
- Non magnetic D-Sub backshells

Straight cable outlet : 405

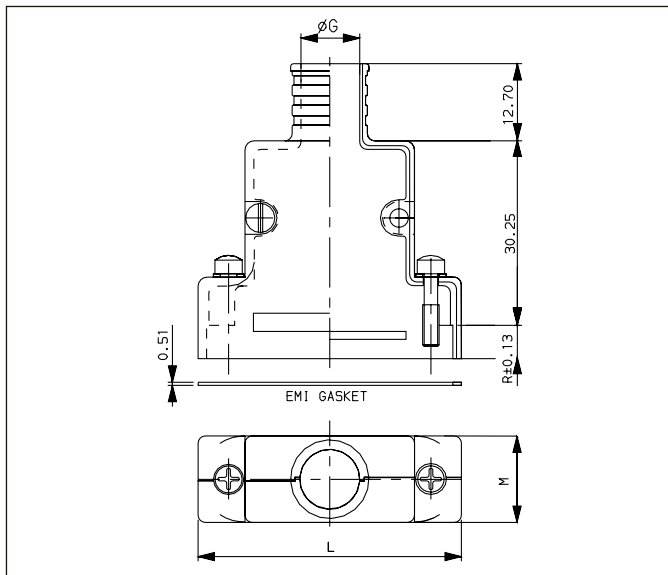

Low profile cable outlet : 401

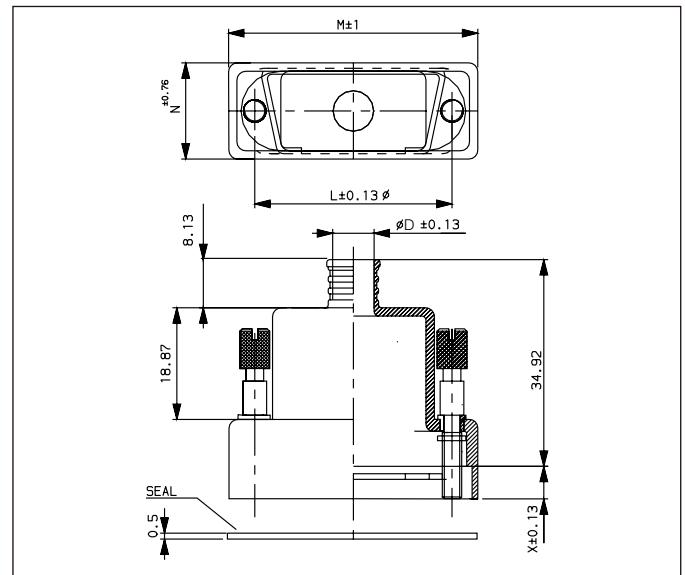

Shell size	M	L	Ø G	Shell size	M	N	L	Standard		Specific	
								★ Cable outlet size	Ø D	★ Cable outlet size	Ø D
E	15,98 .629	35,03 1.379	6,73 .265	E	34,69 1.366	16,25 .640	24,99 .984	B	4,83 .190	C	5,59 .220
A	15,98 .629	43,36 1.707	9,9 .390	A	43,03 1.694	16,25 .640	33,32 1.312	B	4,83 .190	E	6,98 .275
B	15,98 .629	57,25 2.254	10,54 .415	B	56,92 2.241	16,25 .640	47,04 1.852	D	6,6 .260	F	7,24 .285
C	15,98 .629	73,53 2.895	10,54 .415	C	73,2 2.882	16,25 .640	63,5 2.500	D	6,6 .260	G	8,89 .350
D	18,79 .740	71,14 2.801	13,33 .525	D	70,56 2.778	19,05 .750	61,11 2.406	G	8,89 .350	H	12,45 .490



Accessories

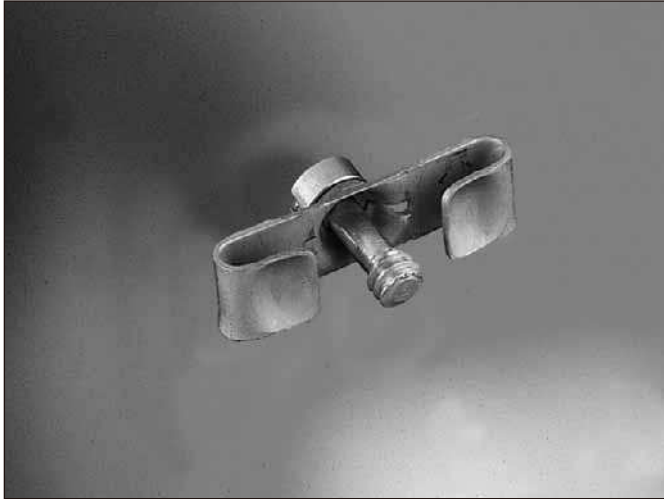

Screw lock

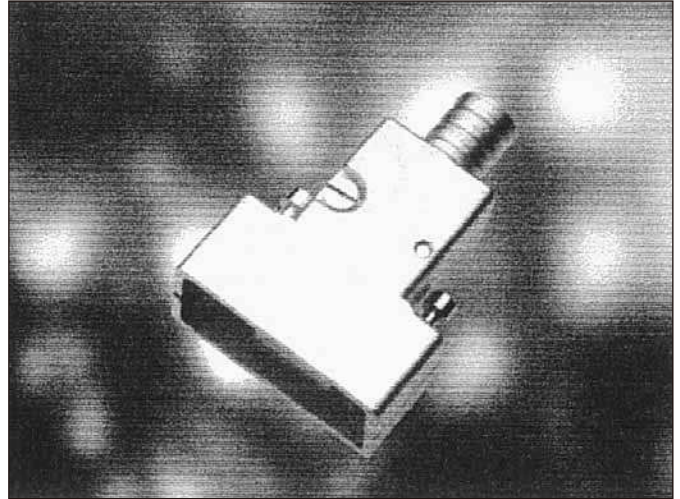

EMI/RFI shielded backshell

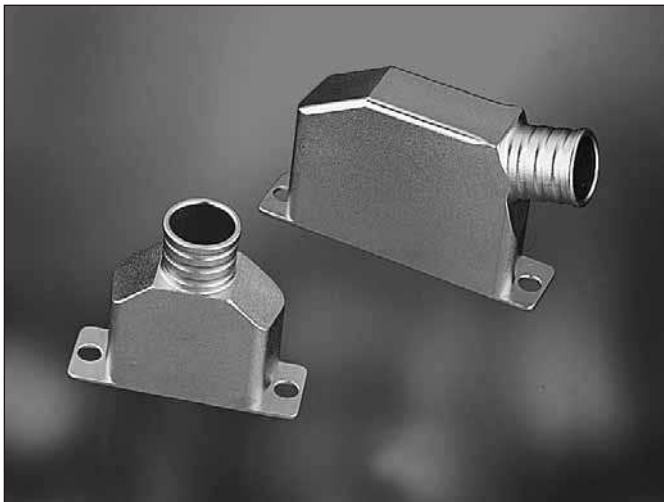

Lightweight shielded backshell

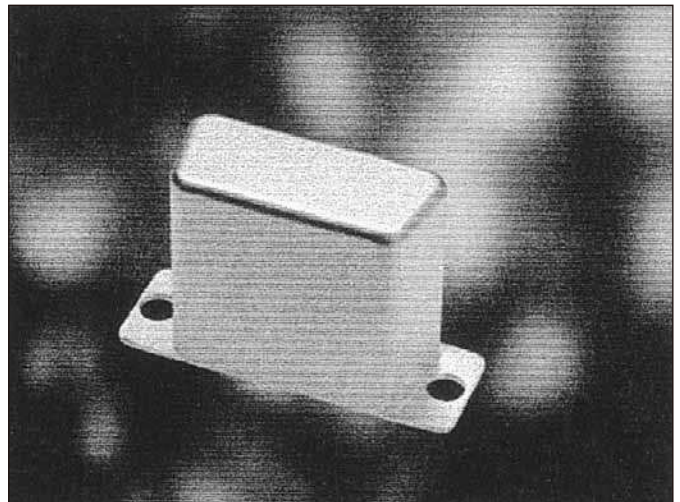

Shorting can

GSFC/ESA-SCC/SOURIAU part number



D-SUB Connectors standard density with solder contacts # 20

PIN CONTACTS			SOCKET CONTACTS		
GSFC P/N	ESA/SCC P/N (Flight Models)	SOURIAU P/N (Engineering Models)	GSFC P/N	ESA/SCC P/N (Flight Models)	SOURIAU P/N (Engineering Models)
311P10-1P-B-12	340100101BDEM9PNMB	DEM 09P 011NMB	311P10-1S-B-12	340100101BDEM9SNMB	DEM 09S 011NMB
311P10-6P-B-12	340100101BDEM5W1PNMB	DEM 5W1P 011NMB	311P10-6S-B-12	340100101BDEM5W1SNMB	DEM 5W1S 011NMB
311P10-2P-B-12	340100101BDAM15PNMB	DAM 15P 011NMB	311P10-2S-B-12	340100101BDAM15SNMB	DAM 15S 011NMB
311P10-7P-B-12	340100101BDAM3W3PNMB	DAM 3W3P 011NMB	311P10-7S-B-12	340100101BDAM3W3SNMB	DAM 3W3S 011NMB
311P10-8P-B-12	340100101BDAM7W2PNMB	DAM 7W2P 011NMB	311P10-8S-B-12	340100101BDAM7W2SNMB	DAM 7W2S 011NMB
311P10-9P-B-12	340100101BDAM11W1PNMB	DAM 11W1P 011NMB	311P10-9S-B-12	340100101BDAM11W1SNMB	DAM 11W1S 011NMB
311P10-3P-B-12	340100101BDBM25PNMB	DBM 25P 011NMB	311P10-3S-B-12	340100101BDBM25SNMB	DBM 25S 011NMB
311P10-10P-B-12	340100101BDBM5W5PNMB	DBM 5W5P 011NMB	311P10-10S-B-12	340100101BDBM5W5SNMB	DBM 5W5S 011NMB
311P10-11P-B-12	340100101BDBM9W4PNMB	DBM 9W4P 011NMB	311P10-11S-B-12	340100101BDBM9W4SNMB	DBM 9W4S 011NMB
311P10-12P-B-12	340100101BDBM13W3PNMB	DBM 13W3P 011NMB	311P10-12S-B-12	340100101BDBM13W3SNMB	DBM 13W3S 011NMB
311P10-13P-B-12	340100101BDBM17W2PNMB	DBM 17W2P 011NMB	311P10-13S-B-12	340100101BDBM17W2SNMB	DBM 17W2S 011NMB
311P10-4P-B-12	340100101BDCM37PNMB	DCM 37P 011NMB	311P10-4S-B-12	340100101BDCM37SNMB	DCM 37S 011NMB
311P10-15P-B-12	340100101BDCM8W8PNMB	DCM 8W8P 011NMB	311P10-15S-B-12	340100101BDCM8W8SNMB	DCM 8W8S 011NMB
311P10-17P-B-12	340100101BDCM17W5PNMB	DCM 17W5P 011NMB	311P10-17S-B-12	340100101BDCM17W5SNMB	DCM 17W5S 011NMB
311P10-18P-B-12	340100101BDCM21WA4PNMB	DCM 21WA4P 011NMB	311P10-18S-B-12	340100101BDCM21WA4SNMB	DCM 21WA4S 011NMB
311P10-20P-B-12	340100101BDCM25W3PNMB	DCM 25W3P 011NMB	311P10-20S-B-12	340100101BDCM25W3SNMB	DCM 25W3S 011NMB
311P10-21P-B-12	340100101BDCM27W2PNMB	DCM 27W2P 011NMB	311P10-21S-B-12	340100101BDCM27W2SNMB	DCM 27W2S 011NMB
311P10-5P-B-12	340100101BDDM50PNMB	DDM 50P 011NMB	311P10-5S-B-12	340100101BDDM50SNMB	DDM 50S 011NMB
311P10-22P-B-12	340100101BDDM24W7PNMB	DDM 24W7P 011NMB	311P10-22S-B-12	340100101BDDM24W7SNMB	DDM 24W7S 011NMB
311P10-23P-B-12	340100101BDDM36W4PNMB	DDM 36W4P 011NMB	311P10-23S-B-12	340100101BDDM36W4SNMB	DDM 36W4S 011NMB

D-SUB Connectors standard density with crimp contacts # 20

D-SUB Connectors high density with crimp contacts # 22

PIN CONTACTS			PIN CONTACTS		
GSFC P/N	ESA/SCC P/N (Flight Models)	SOURIAU P/N (Engineering Models)	GSFC P/N	ESA/SCC P/N (Flight Models)	SOURIAU P/N (Engineering Models)
311P409-1P-B-12	340100201BDEMA9PNMBFO	8630 09P NMBL	311P407-1P-B-12	340100202BDEMA15PNMBFO	8635 15P NMBL
311P409-2P-B-12	340100201BDAMA15PNMBFO	8630 15P NMBL	311P407-2P-B-12	340100202BDAMA26PNMBFO	8635 26P NMBL
311P409-3P-B-12	340100201BDBMA25PNMBFO	8630 25P NMBL	311P407-3P-B-12	340100202BDBMA44PNMBFO	8635 44P NMBL
311P409-4P-B-12	340100201BDCMA37PNMBFO	8630 37P NMBL	311P407-4P-B-12	340100202BDCMA62PNMBFO	8635 62P NMBL
311P409-5P-B-12	340100201BDDMA50PNMBFO	8630 50P NMBL	311P407-5P-B-12	340100202BDDMA78PNMBFO	8635 78P NMBL
SOCKET CONTACTS			SOCKET CONTACTS		
311P409-1S-B-12	340100201BDEMA9SNMBFO	8630 09S NMBL	311P407-1S-B-12	340100202BDEMA15SNMBFO	8635 15S NMBL
311P409-2S-B-12	340100201BDAMA15SNMBFO	8630 15S NMBL	311P407-2S-B-12	340100202BDAMA26SNMBFO	8635 26S NMBL
311P409-3S-B-12	340100201BDBMA25SNMBFO	8630 25S NMBL	311P407-3S-B-12	340100202BDBMA44SNMBFO	8635 44S NMBL
311P409-4S-B-12	340100201BDCMA37SNMBFO	8630 37S NMBL	311P407-4S-B-12	340100202BDCMA62SNMBFO	8635 62S NMBL
311P409-5S-B-12	340100201BDDMA50SNMBFO	8630 50S NMBL	311P407-5S-B-12	340100202BDDMA78SNMBFO	8635 78S NMBL

Crimp contacts # 20, rear insertable and rear removable

GSFC P/N	ESA/SCC P/N (Flight Models)	SOURIAU P/N (Engineering Models)
G10P1	340100501B	8949 1196 Y7 EL
G10S1	340100502B	8949 1198 EL
-	340100503B	8949 1520 Y7 EL
-	340100504B	8949 1523 EL
-	340100505B	8949 3227 Y7 EL
-	340100506B	8949 3352 EL

Crimp contacts # 22, rear insertable and rear removable

GSFC P/N	ESA/SCC P/N (Flight Models)	SOURIAU P/N (Engineering Models)
G08P1	340100507B	8949 1524 Y7 EL
G08S1	340100508B	8949 1525 EL

Компания «Океан Электроники» предлагает заключение долгосрочных отношений при поставках импортных электронных компонентов на взаимовыгодных условиях!

Наши преимущества:

- Поставка оригинальных импортных электронных компонентов напрямую с производств Америки, Европы и Азии, а так же с крупнейших складов мира;
- Широкая линейка поставок активных и пассивных импортных электронных компонентов (более 30 млн. наименований);
- Поставка сложных, дефицитных, либо снятых с производства позиций;
- Оперативные сроки поставки под заказ (от 5 рабочих дней);
- Экспресс доставка в любую точку России;
- Помощь Конструкторского Отдела и консультации квалифицированных инженеров;
- Техническая поддержка проекта, помощь в подборе аналогов, поставка прототипов;
- Поставка электронных компонентов под контролем ВП;
- Система менеджмента качества сертифицирована по Международному стандарту ISO 9001;
- При необходимости вся продукция военного и аэрокосмического назначения проходит испытания и сертификацию в лаборатории (по согласованию с заказчиком);
- Поставка специализированных компонентов военного и аэрокосмического уровня качества (Xilinx, Altera, Analog Devices, Intersil, Interpoint, Microsemi, Actel, Aeroflex, Peregrine, VPT, Syfer, Eurofarad, Texas Instruments, MS Kennedy, Miteq, Cobham, E2V, MA-COM, Hittite, Mini-Circuits, General Dynamics и др.);

Компания «Океан Электроники» является официальным дистрибьютором и эксклюзивным представителем в России одного из крупнейших производителей разъемов военного и аэрокосмического назначения «**JONHON**», а так же официальным дистрибьютором и эксклюзивным представителем в России производителя высокотехнологичных и надежных решений для передачи СВЧ сигналов «**FORSTAR**».



JONHON

«**JONHON**» (основан в 1970 г.)

Разъемы специального, военного и аэрокосмического назначения:

(Применяются в военной, авиационной, аэрокосмической, морской, железнодорожной, горно- и нефтедобывающей отраслях промышленности)

«**FORSTAR**» (основан в 1998 г.)

ВЧ соединители, коаксиальные кабели, кабельные сборки и микроволновые компоненты:

(Применяются в телекоммуникациях гражданского и специального назначения, в средствах связи, РЛС, а так же военной, авиационной и аэрокосмической отраслях промышленности).



Телефон: 8 (812) 309-75-97 (многоканальный)

Факс: 8 (812) 320-03-32

Электронная почта: ocean@oceanchips.ru

Web: <http://oceanchips.ru/>

Адрес: 198099, г. Санкт-Петербург, ул. Калинина, д. 2, корп. 4, лит. А