



DESCRIPTION

PT2268 is a remote control encoder utilizing CMOS Technology specially designed for use with the PT2128. Using a special coding technique, PT2268 increases noise immunity to a very great extent. It is housed in 16-Pins DIP Package and has a maximum of eight (8) input channels. Its high performance features make PT2268 a MUST in every fan and other electrical home appliance remote control application.

PTC provides a new version of PT2268 which can be identified by the “B” mark on the lower right hand corner of the IC’s topcode (beside the date code). Please refer to the diagram on the Order Information Section. The difference between the old and new version is the external application circuit in the OSC1 and OSC2 pins. (see Oscillator Section)

FEATURES

- CMOS technology
- Low power consumption
- Very high noise immunity
- Wide range of operating voltage: $V_{cc}=2.2 \sim 5.0V$
- Transmits signals to a maximum of 8 channels
- Start word custom code options available (Please contact PTC for details.)

APPLICATIONS

- Fan remote control
- Air cleaner
- Humidifier
- Heater



BLOCK DIAGRAM

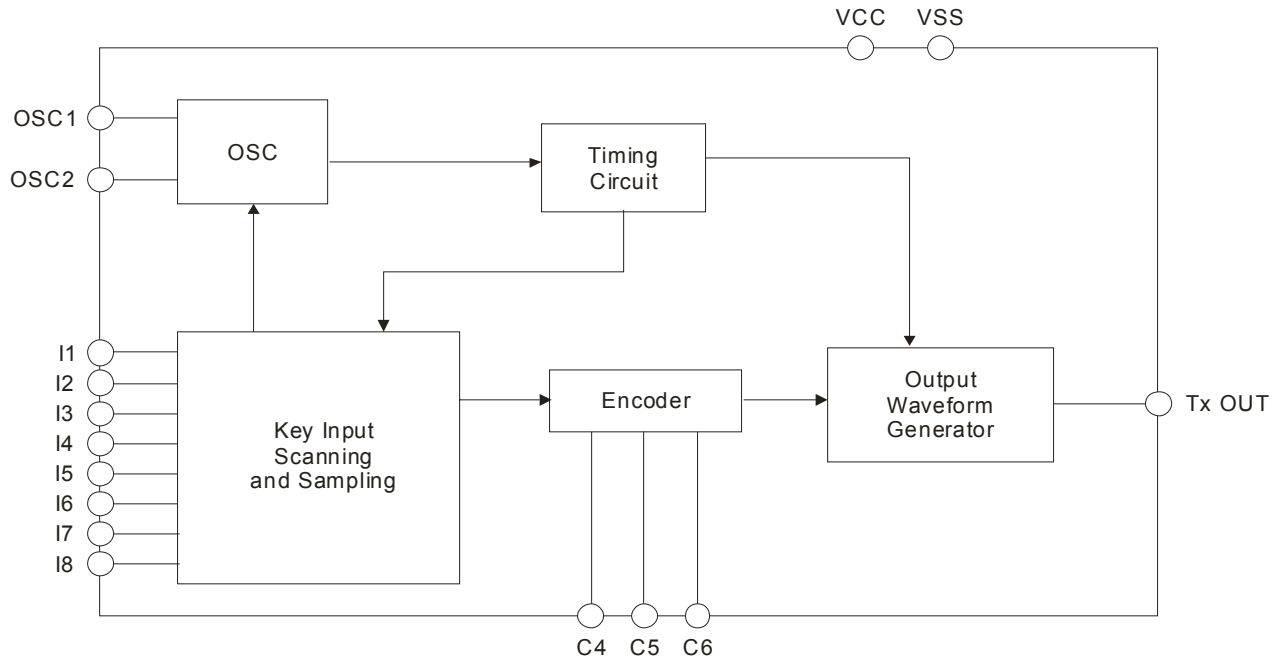



PIN CONFIGURATION

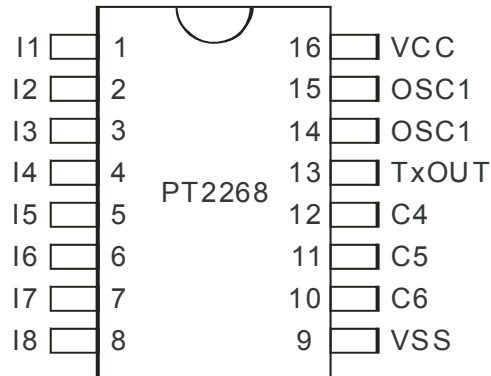

PIN DESCRIPTION

Pin Name	I/O	Description	Pin No.
I1 ~ I8	I	Key Input Pins. These pins are used to connect a maximum of 8 keys. (Each pin has a built-in pull-low resistor.)	1 ~ 8
VSS	-	Negative Power Supply	9
C4 ~ C5	I	Select Input Pin for Start Word These pins have internal pull-low resistors.	12 ~ 11
C6	I	Select Input Pin for Start Word This pin has an internal pull-high resistor.	10
Tx OUT	O	Transmission Output Pin. This pin is an open drain (NMOS) output and is used to transmit signals. The carrier frequency is 38 KHz.	13
OSC1	I	Oscillator No.1 Pin	15
OSC2	O	Oscillator No.2 Pin	14
VCC	-	Positive Power Supply	16



FUNCTION DESCRIPTION

KEY INPUT

Up to eight (8) keys can be directly connected to pins I1 ~ I8. Please refer to the diagram below.

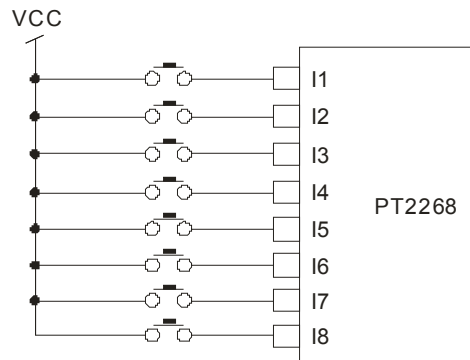

Furthermore, PT2268 has a built-in pull-low resistor of about 60K ~ 110KΩ which reduces the need for external components.

OSCILLATOR

An oscillation circuit can be constructed using the CMOS Inverter and Built-in Feedback Resistor, 455KHz Crystal and two 220pF capacitors. The carrier frequency is 38KHz.

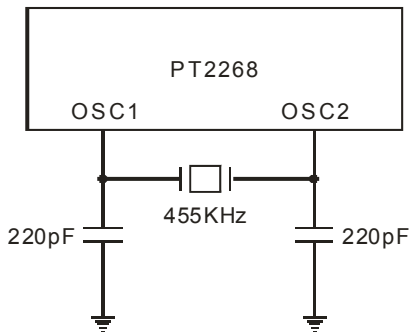

Unless any of the 8 keys (I1 ~ I8) is being operated, the oscillation is automatically stopped. Thus, power consumption is considerably reduced.



TRANSMISSION WAVEFORM

When any of the 8 keys (I1 ~ I8) is set to “High”, the TxOUT outputs one start word followed by 2 identical data words and a space. The code will be continuously outputted until the key is released. If for any reason, the key was released during the code transmission process, the code that is being transmitted during the key release action will still be completely outputted. Please refer to the following diagram.

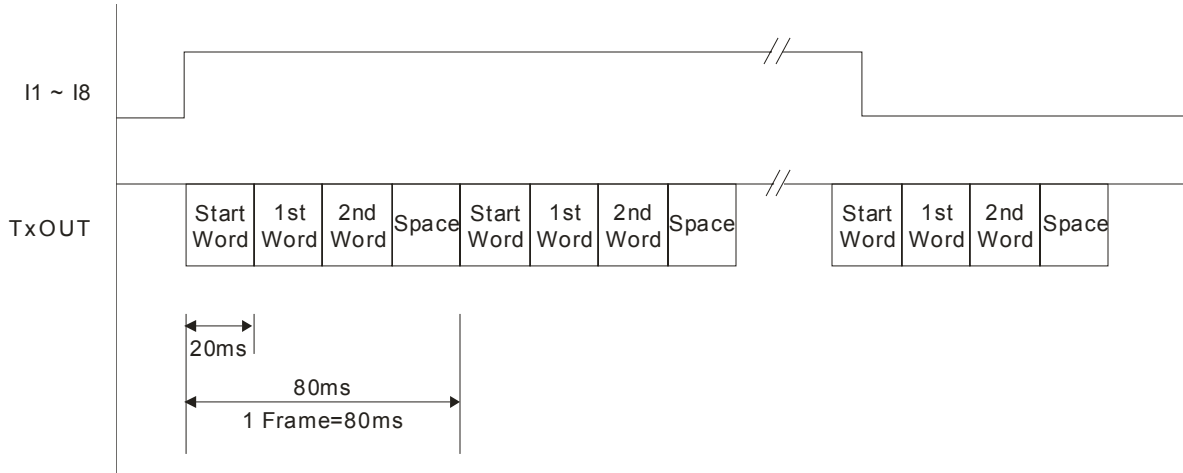

Note: OSC=455KHz

TRANSMISSION CODE WAVEFORM

The transmission waveforms of the Start Word and the different Data Words generated when a specific input key (I1 ~ I8) is pressed are illustrated below (see also Transmission Code Pattern Section).

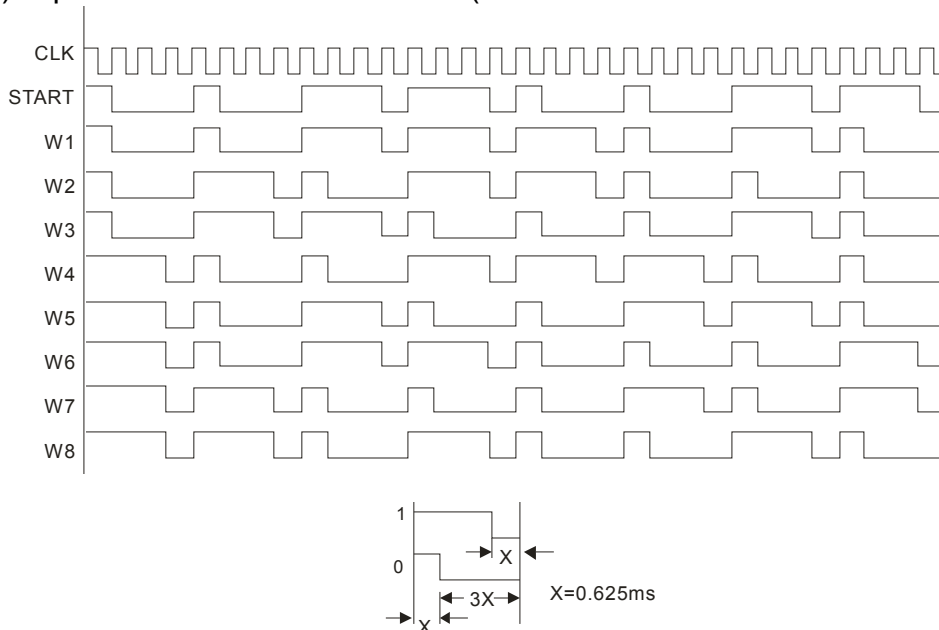



TRANSMISSION CODE PATTERN

The transmission code pattern of PT2268 is given in the table below. Please refer to PT2265 transmission code pattern.

	Transmission	LSB							MSB		Receiver
		C0	C1	C2	C3	C4	C5	C6	C7		
Start Word		0	0	1	1	0	0	1	1		
		B0	B1	B2	B3	B4	B5	B6	B7		
Data Word (Key pressed)	W1 (I1)	0	0	1	1	1	0	1	0	0/p1	
	W2 (I2)	0	1	0	1	1	0	0	0	0/p2	
	W3 (I3)	0	1	1	0	0	0	1	0	0/p3	
	W4 (I4)	1	0	0	1	1	1	0	0	0/p4	
	W5 (I5)	1	0	1	0	0	1	1	0	0/p5	
	W6 (I6)	1	0	1	1	0	0	0	1	0/p6	
	W7 (I7)	1	1	0	0	0	1	0	1	0/p7	
	W8 (I8)	1	1	0	1	0	0	1	0	0/p8	

START WORD CUSTOM CODE

The start word custom code has the following format:

LSB								MSB
0	0	1	C3	C4	C5	C6	1	

where:

C3=1 (default value)

=bonding option available

C4="0" when floating or connected to VSS

= "1" when connected to VCC

C5="0" when floating or connected to VSS

= "1" when connected to VCC

C6="0" when connected to VSS

= "1" when floating or connected to VCC

Note: C4 and C5 have internal pull-low resistors while C6 has an internal pull-high resistor.



Remote Control Encoder

PT2268

The start word custom code table is given below:

C3=0			C3=1(default)
C4	C5	C6	Custom Code (C0 TO C7)
0	0	0	00100001
0	0	1	00100011
0	1	0	00100101
0	1	1	00100111
1	0	0	00101001
1	0	1	00101011
1	1	0	00101101
1	1	1	00101111

OPERATION FLOWCHART

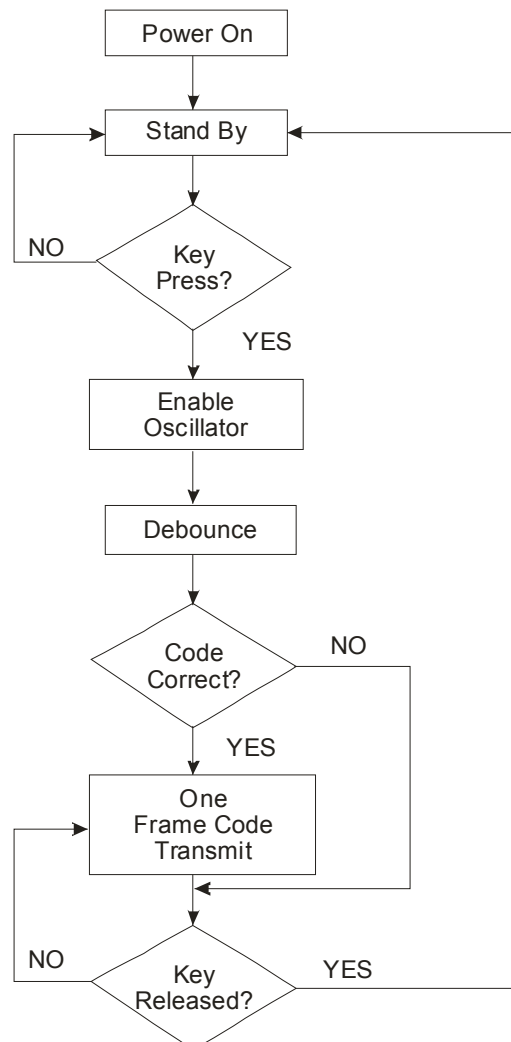



ABSOLUTE MAXIMUM RATINGS

Parameter	Symbol	Rating	Unit
Supply voltage	Vcc	0 ~ 6.0	V
Input/Output voltage	Vin/Vout	Vss-0.2 ~ Vcc+0.3	V
Power dissipation	PD	500	mW
Operating temperature	Topr	-40 ~ +85	°C
Storage temperature	Tstg	-65 ~ +150	°C

ELECTRICAL CHARACTERISTICS

Normal Operating Condition: Ta=0°C ~ +70°C, VCC-VSS=3V±10%

Parameter	Symbol	Condition	Min.	Typ.	Max.	Unit
Operating voltage	VCC		2.2	3	5	V
Operating current	IOP	OSC On TxOUT is floating. (See Note)		500	1000	μA
Stand-by current	ISB	I1 ~ I8="L" OSC Stops. TxOUT is floating.	0.5	1	3	μA
Sinking current of TxOUT	ISINK	VOL=2.2 V, VDD=3V VOL=1.5 V, VDD=3V	8 4	15 6		mA
Input voltage of I1 ~ I8	VIH VIL		0.7VCC 0	- -	VCC 0.3VCC	V
Input pull-low resistor	RL		30	50	80	KΩ
Input pull-high resistor	RH		40	90	150	KΩ
OSC frequency				455		KHz

Note: For pins I1~I8: Any one of the said pins is set to HIGH while the others are set to LOW.



APPLICATION CIRCUIT

PT2268 IR Transmitter Application Circuit

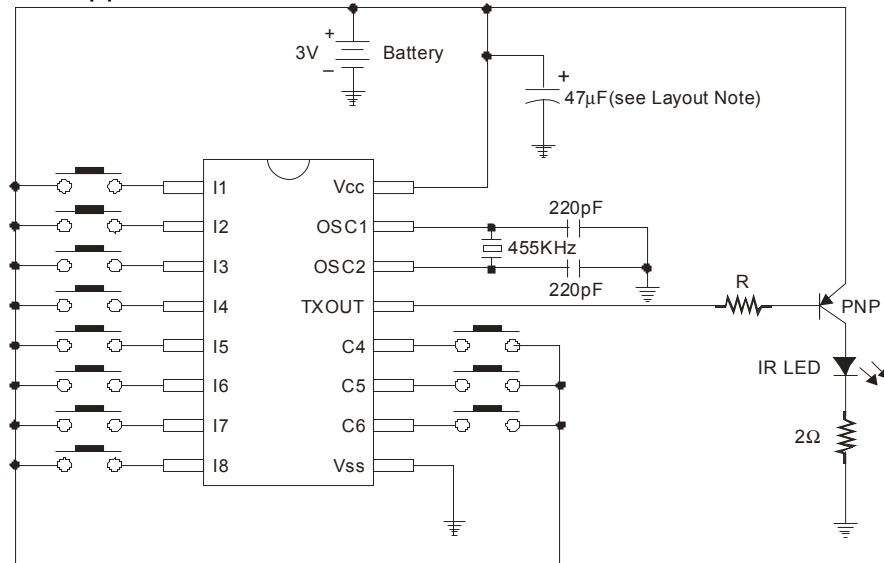

Notes:

1. C3 (default value)=1. For more details, please refer to Start Word Custom Code Section.
2. Resistor (R) is the Current Limit Impedance whose value must be greater than 220Ω . Resistor (R) Recommended Value= $1K\Omega$

Layout Note: Place $47\mu F$ capacitor as near as possible to the PT2268's VSS Pin.



ORDER INFORMATION

Valid Part Number	Package Type	Top Code
PT2268P8-Z	8 Pins, DIP, 300mil	PT2268P8-Z
PT2268Z	16 Pins, DIP, 300mil	PT2268Z
PT2268Z-S	16 Pins, SOP, 300mil	PT2268Z-S



PACKAGE INFORMATION

8 PINS, DIP, 300MIL

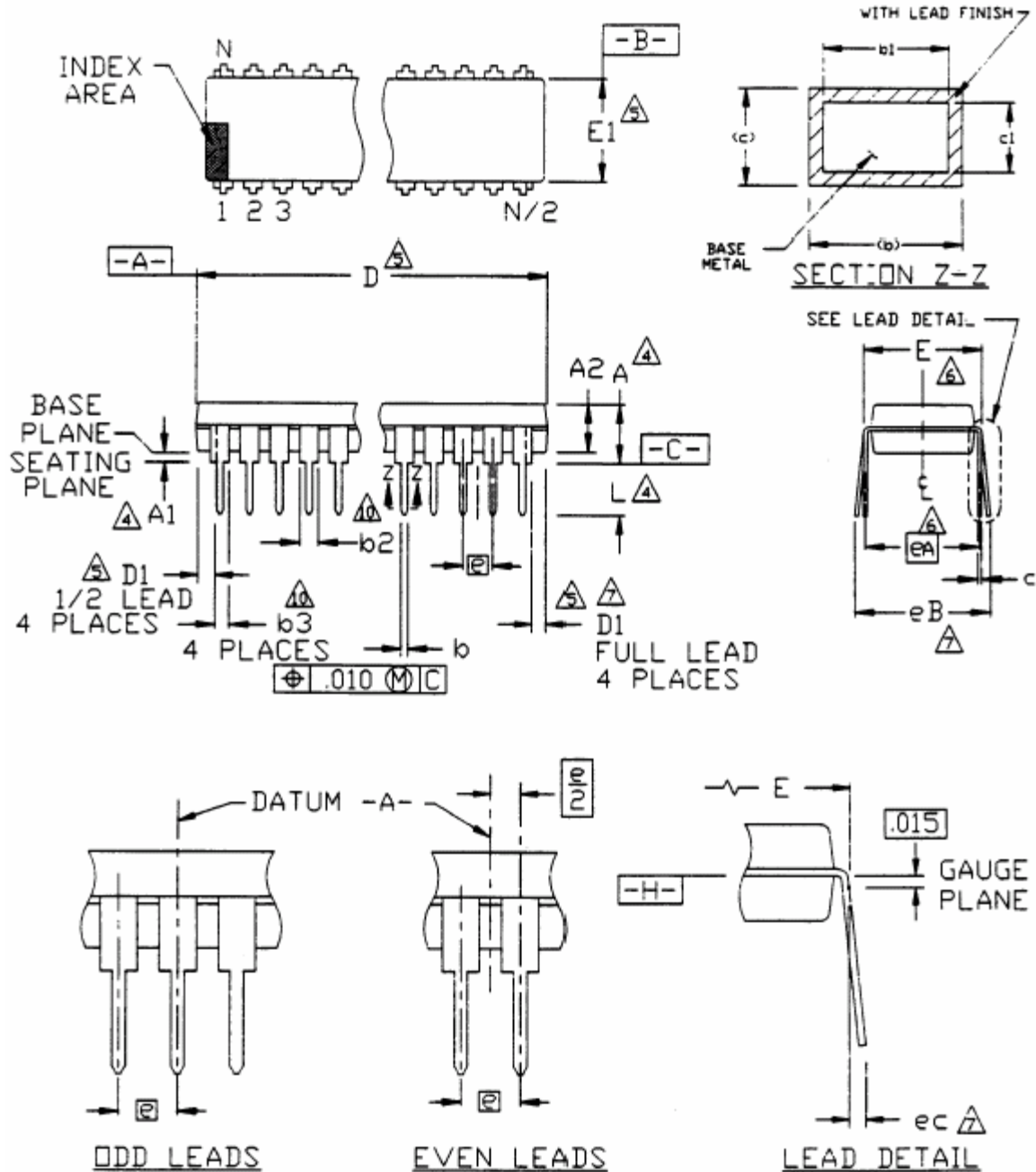



Symbol	Min.	Nom.	Max.
A	-	-	0.210
A1	0.015	-	-
A2	0.115	0.130	0.195
b	0.014	0.018	0.022
b1	0.014	0.018	0.020
b2	0.045	0.060	0.070
b3	0.030	0.039	0.045
c	0.008	0.010	0.014
c1	0.008	0.010	0.011
D	0.355	0.365	0.400
D1	0.005	-	-
E	0.300	0.310	0.325
E1	0.240	0.250	0.280
e	0.100 BSC.		
eA	0.300 BSC.		
eB	-	-	0.430
eC	0.000	-	0.060
L	0.115	0.130	0.150

Notes:

- Controlling Dimension: INCHES.
- Dimensioning and tolerancing per ANSI Y14.5M-1982.
- Symbols are defined in the "MO Series Symbol LIST" in Section 2.2 of Publication No.95.
- Dimensions A, A1 and L are measured with the package seated in JEDEC Seating Plane Gauge GS-3.
- D, D1 and E1 dimension do not include mold flash or protrusions. Mold flash or protrusions shall not exceed 0.010 inch.
- E and eA measured with the leads constrained to be perpendicular to data -C- .
- eB and eC are measured at the lead tips with the leads unconstrained.
- N is the number of leads (N=8).
- Pointed or rounded lead tips are preferred to ease insertion.
- b2 and b3 maximum dimensions do not include dambar protrusions. Dambar protrusions shall not exceed 0.010 (0.25mm).
- Variation BA has a b3 dimension and is 1/2 lead package.
- Distance between the leads including dambar protrusions to be 0.005 inch minimum.
- Datum plane -H- coincident with the bottom of lead where lead exits the body.
- Refer to JEDEC MS-001 variation BA.

JEDEC is the registered trademark of JEDEC SOLID STATE TECHNOLOGY ASSOCIATION.



Remote Control Encoder

PT2268

16 PINS, DIP, 300MIL

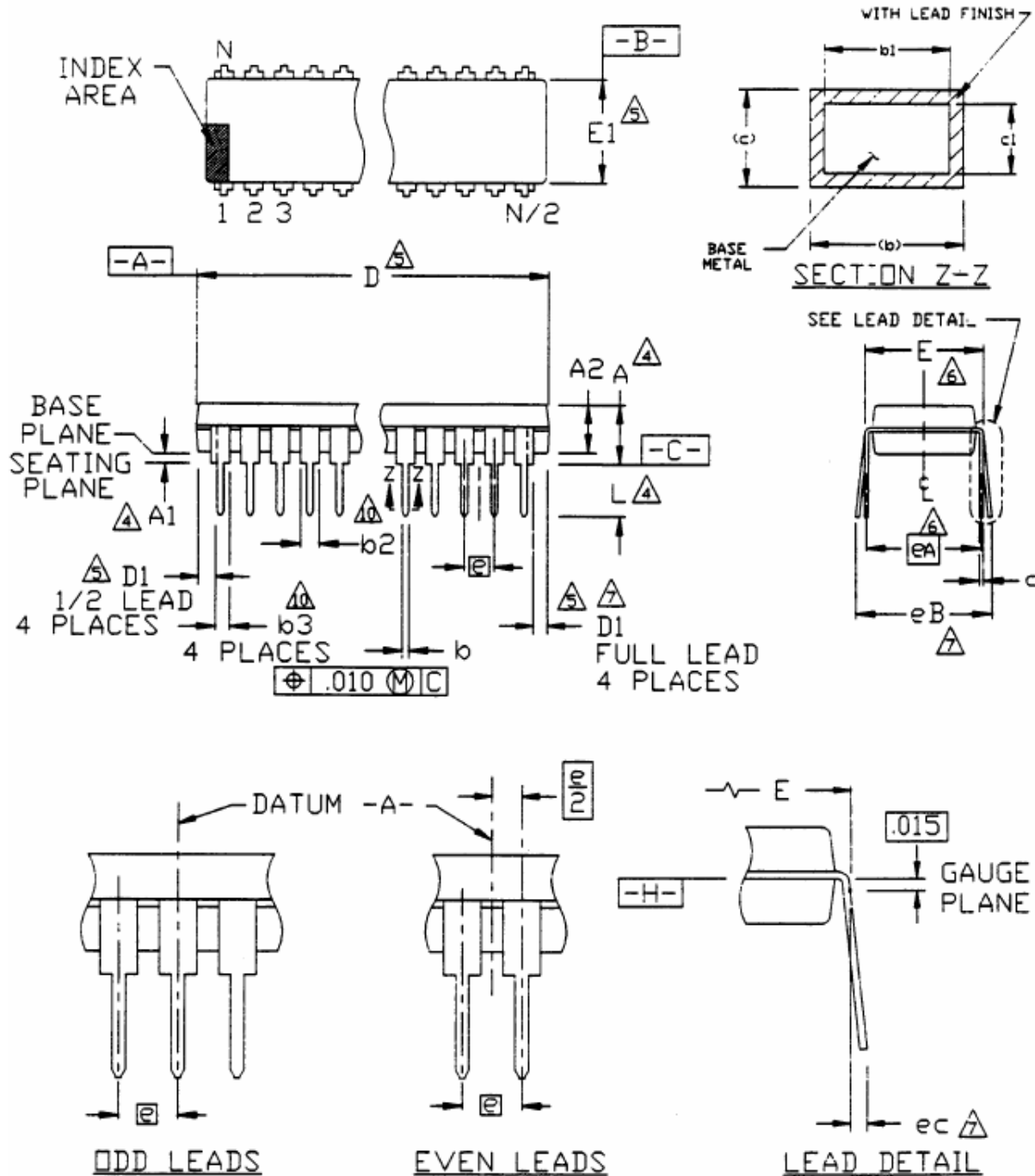



Symbol	Min.	Nom.	Max.
A			0.210
A1	0.015		
A2	0.115	0.130	0.195
b	0.014	0.018	0.022
b1	0.014	0.018	0.020
b2	0.045	0.060	0.070
b3	0.030	0.039	0.045
c	0.008	0.010	0.014
c1	0.008	0.010	0.011
D	0.780	0.790	0.800
D1	0.005		
E	0.300	0.310	0.325
E1	0.240	0.250	0.280
e	0.100 bsc.		
eA	0.300 bsc.		
eB			0.430
eC	0.000		0.060
L	0.115	0.130	0.150

Notes:

- All dimensions are in INCHS.
 - Dimensioning and tolerancing per ANSI Y14.5M-1982.
 - Dimensions "A", "A1" and "L" are measured with the package seated in JEDEC Seating Plane Gauge GS-3.
 - "D", "D1" and "E1" dimensions do not include mold flash or protrusions. Mold flash or protrusions shall not exceed 0.010 inch.
 - "E" and "eA" measured with the leads constrained to be perpendicular to datum $\square\text{-C-}$.
 - "eB" and "eC" are measured at the lead tips with the loads unconstrained.
 - "N" is the number of terminal positions. (N=16)
 - Pointed or rounded lead tips are preferred to ease insertion.
 - "b2" and "b3" maximum dimensions are not include dambar protrusions. Dambar protrusions shall not exceed 0.010 inch (0.25 mm).
 - Distance between leads including Dambar protrusions to be 0.005 inch minimum.
 - Datum plane $\square\text{-H-}$ coincident with the bottom of lead, where lead exits body.
 - Refer to JEDEC MS-001 Variation AB.
- JEDEC is the trademark of JEDEC SOLID STATE TECHNOLOGY ASSOCIATION.



Remote Control Encoder

PT2268

16 PINS, SOP, 300MIL

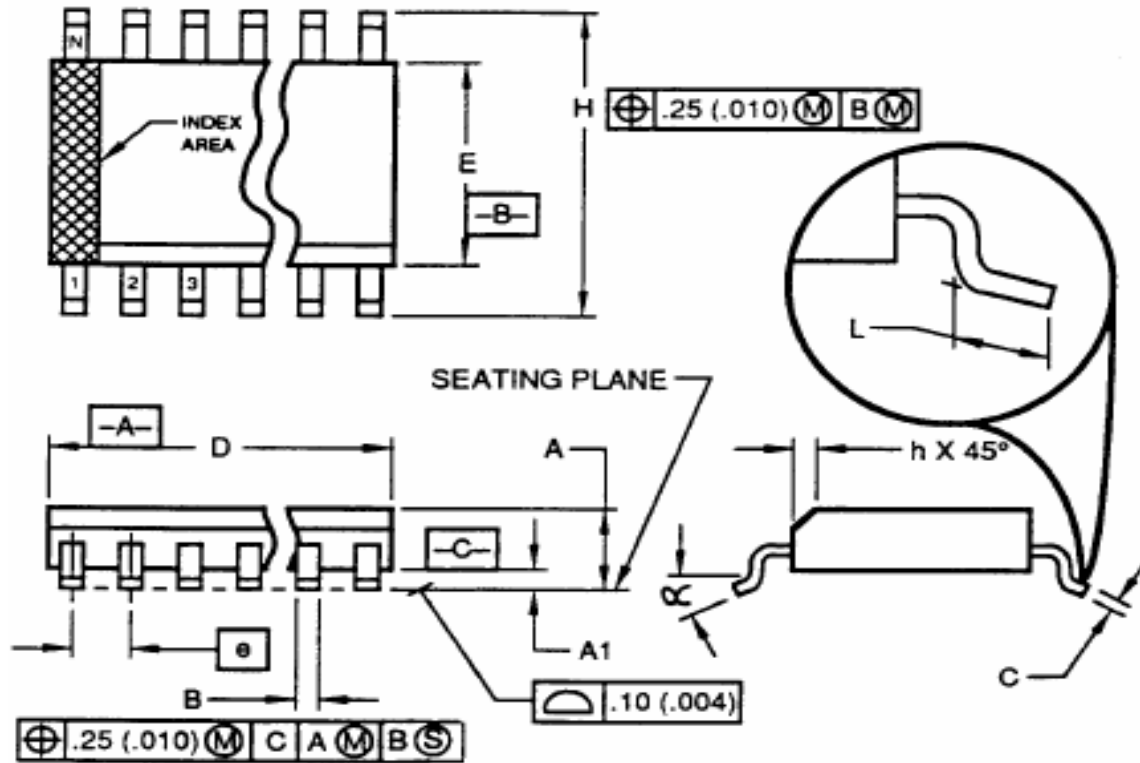

Symbol	Min.	Nom.	Max.
A	2.35		2.65
A1	0.10		0.30
B	0.33		0.51
C	0.23		0.32
D	10.10		10.50
E	7.40		7.60
e	1.27 bsc.		
H	10.00		10.65
h	0.25		0.75
L	0.40		1.27
α	0°		8°



Remote Control Encoder

PT2268

Notes:

1. Dimensioning and tolerancing per ANSI Y14.5-1982.
 2. Dimension "D" does not include mold flash, protrusions or gate burrs. Mold Flash protrusion or gate burrs shall not exceed 0.15mm (0.006 in) per side.
 3. Dimension "E" does not include interlead flash or protrusions. Interlead flash or protrusions shall not exceed 0.25 mm (0.010 in) per side.
 4. The chamfer on the body is optional. It is not present, a visual index feature must be located within the crosshatched area.
 5. "L" is the length of the terminal for soldering to a substrate.
 6. "N" is the number of terminal positions. (N=16)
 7. The lead width "B" as measured 0.36 mm (0.014 in) or greater above the seating plane, shall not exceed a maximum value of 0.61 mm (0.24 in).
 8. Controlling dimension: MILLIMETER.
 9. Refer to JEDEC MS-013 Variation AA
- JEDEC is the trademark of JEDEC SOLID STATE TECHNOLOGY ASSOCIATION.

Компания «Океан Электроники» предлагает заключение долгосрочных отношений при поставках импортных электронных компонентов на взаимовыгодных условиях!

Наши преимущества:

- Поставка оригинальных импортных электронных компонентов напрямую с производств Америки, Европы и Азии, а так же с крупнейших складов мира;
- Широкая линейка поставок активных и пассивных импортных электронных компонентов (более 30 млн. наименований);
- Поставка сложных, дефицитных, либо снятых с производства позиций;
- Оперативные сроки поставки под заказ (от 5 рабочих дней);
- Экспресс доставка в любую точку России;
- Помощь Конструкторского Отдела и консультации квалифицированных инженеров;
- Техническая поддержка проекта, помощь в подборе аналогов, поставка прототипов;
- Поставка электронных компонентов под контролем ВП;
- Система менеджмента качества сертифицирована по Международному стандарту ISO 9001;
- При необходимости вся продукция военного и аэрокосмического назначения проходит испытания и сертификацию в лаборатории (по согласованию с заказчиком);
- Поставка специализированных компонентов военного и аэрокосмического уровня качества (Xilinx, Altera, Analog Devices, Intersil, Interpoint, Microsemi, Actel, Aeroflex, Peregrine, VPT, Syfer, Eurofarad, Texas Instruments, MS Kennedy, Miteq, Cobham, E2V, MA-COM, Hittite, Mini-Circuits, General Dynamics и др.);

Компания «Океан Электроники» является официальным дистрибьютором и эксклюзивным представителем в России одного из крупнейших производителей разъемов военного и аэрокосмического назначения «JONHON», а так же официальным дистрибьютором и эксклюзивным представителем в России производителя высокотехнологичных и надежных решений для передачи СВЧ сигналов «FORSTAR».



JONHON

«JONHON» (основан в 1970 г.)

Разъемы специального, военного и аэрокосмического назначения:

(Применяются в военной, авиационной, аэрокосмической, морской, железнодорожной, горно- и нефтедобывающей отраслях промышленности)

«FORSTAR» (основан в 1998 г.)

ВЧ соединители, коаксиальные кабели, кабельные сборки и микроволновые компоненты:

(Применяются в телекоммуникациях гражданского и специального назначения, в средствах связи, РЛС, а так же военной, авиационной и аэрокосмической отраслях промышленности).



Телефон: 8 (812) 309-75-97 (многоканальный)

Факс: 8 (812) 320-03-32

Электронная почта: ocean@oceanchips.ru

Web: <http://oceanchips.ru/>

Адрес: 198099, г. Санкт-Петербург, ул. Калинина, д. 2, корп. 4, лит. А