

MC14551B

Quad 2-Channel Analog Multiplexer/Demultiplexer

The MC14551B is a digitally-controlled analog switch. This device implements a 4PDT solid state switch with low ON impedance and very low OFF Leakage current. Control of analog signals up to the complete supply voltage range can be achieved.

Features

- Triple Diode Protection on All Control Inputs
- Supply Voltage Range = 3.0 Vdc to 18 Vdc
- Analog Voltage Range ($V_{DD} - V_{EE}$) = 3.0 to 18 V
Note: V_{EE} must be $\leq V_{SS}$
- Linearized Transfer Characteristics
- Low Noise — 12 nV/ $\sqrt{\text{Cycle}}$, $f \geq 1.0$ kHz typical
- For Low R_{ON} , Use The HC4051, HC4052, or HC4053 High-Speed CMOS Devices
- Switch Function is Break Before Make
- These Devices are Pb-Free and are RoHS Compliant

MAXIMUM RATINGS

Parameter	Symbol	Value	Unit
DC Supply Voltage Range (Referenced to V_{EE} , $V_{SS} \geq V_{EE}$)	V_{DD}	- 0.5 to + 18.0	V
Input or Output Voltage (DC or Transient) (Referenced to V_{SS} for Control Input and V_{EE} for Switch I/O)	V_{in} , V_{out}	- 0.5 to V_{DD} + 0.5	V
Input Current (DC or Transient), per Control Pin	I_{in}	± 10	mA
Switch Through Current	I_{sw}	± 25	mA
Power Dissipation, per Package (Note 1)	P_D	500	mW
Ambient Temperature Range	T_A	- 55 to + 125	$^{\circ}\text{C}$
Storage Temperature Range	T_{stg}	- 65 to + 150	$^{\circ}\text{C}$
Lead Temperature (8-Second Soldering)	T_L	260	$^{\circ}\text{C}$

Stresses exceeding Maximum Ratings may damage the device. Maximum Ratings are stress ratings only. Functional operation above the Recommended Operating Conditions is not implied. Extended exposure to stresses above the Recommended Operating Conditions may affect device reliability.

1. Temperature Derating: Plastic "P and D/DW"
Packages: - 7.0 mW/ $^{\circ}\text{C}$ From 65 $^{\circ}\text{C}$ To 125 $^{\circ}\text{C}$

This device contains protection circuitry to guard against damage due to high static voltages or electric fields. However, precautions must be taken to avoid applications of any voltage higher than maximum rated voltages to this high-impedance circuit. For proper operation, V_{in} and V_{out} should be constrained to the range $V_{SS} \leq (V_{in} \text{ or } V_{out}) \leq V_{DD}$ for control inputs and $V_{EE} \leq (V_{in} \text{ or } V_{out}) \leq V_{DD}$ for Switch I/O.

Unused inputs must always be tied to an appropriate logic voltage level (e.g., either V_{SS} , V_{EE} or V_{DD}). Unused outputs must be left open.



ON Semiconductor®

<http://onsemi.com>

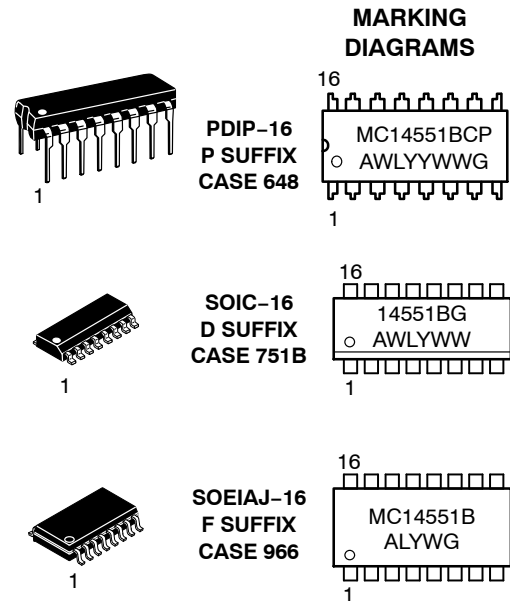

A = Assembly Location
WL, L = Wafer Lot
YY, Y = Year
WW, W = Work Week
G = Pb-Free Package

ORDERING INFORMATION

See detailed ordering and shipping information in the package dimensions section on page 2 of this data sheet.

MC14551B

PIN ASSIGNMENT

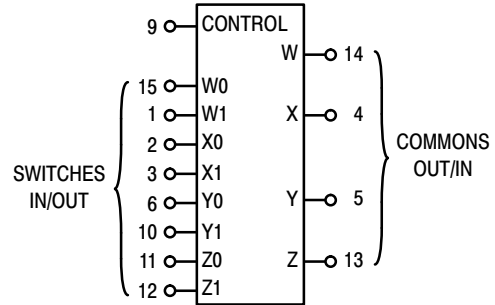
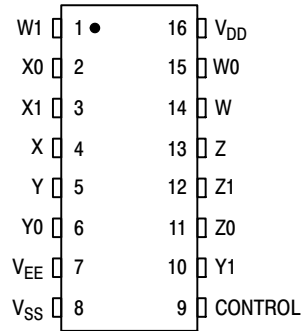

V_{DD} = Pin 16
V_{SS} = Pin 8
V_{EE} = Pin 7

Control	ON
0	W0 X0 Y0 Z0
1	W1 X1 Y1 Z1

NOTE: Control Input referenced to V_{SS}. Analog Inputs and Outputs reference to V_{EE}. V_{EE} must be ≤ V_{SS}.

ORDERING INFORMATION

Device	Package	Shipping [†]
MC14551BCPG	PDIP-16 (Pb-Free)	25 Units / Rail
MC14551BDG	SOIC-16 (Pb-Free)	48 Units / Rail
MC14551BDR2G	SOIC-16 (Pb-Free)	2500 / Tape & Reel
MC14551BFG	SOEIAJ-16 (Pb-Free)	50 Units / Rail

[†]For information on tape and reel specifications, including part orientation and tape sizes, please refer to our Tape and Reel Packaging Specifications Brochure, BRD8011/D.

MC14551B

ELECTRICAL CHARACTERISTICS

Characteristic	V _{DD}	Test Conditions	Symbol	- 55°C		25°C		125°C		Unit
				Min	Max	Min	Typ (Note 2)	Max	Min	

SUPPLY REQUIREMENTS (Voltages Referenced to V_{EE})

Power Supply Voltage Range	-	$V_{DD} - 3.0 \geq V_{SS} \geq V_{EE}$	V _{DD}	3.0	18	3.0	-	18	3.0	18	V
Quiescent Current Per Package	5.0 10 15	Control Inputs: V _{in} = V _{SS} or V _{DD} , Switch I/O: V _{EE} ≤ V _{I/O} ≤ V _{DD} , and ΔV _{switch} ≤ 500 mV (Note 3)	I _{DD}	-	5.0 10 20	-	0.005 0.010 0.015	5.0 10 20	-	150 300 600	μA
Total Supply Current (Dynamic Plus Quiescent, Per Package)	5.0 10 15	T _A = 25°C only (The channel component, (V _{in} - V _{out})/R _{on} , is not included.)	I _{D(AV)}	Typical (0.07 μA/kHz) f + I _{DD} (0.20 μA/kHz) f + I _{DD} (0.36 μA/kHz) f + I _{DD}						μA	

CONTROL INPUT (Voltages Referenced to V_{SS})

Low-Level Input Voltage	5.0 10 15	R _{on} = per spec, I _{off} = per spec	V _{IL}	-	1.5 3.0 4.0	-	2.25 4.50 6.75	1.5 3.0 4.0	-	1.5 3.0 4.0	V
High-Level Input Voltage	5.0 10 15	R _{on} = per spec, I _{off} = per spec	V _{IH}	3.5 7.0 11	-	3.5 7.0 11	2.75 5.50 8.25	-	3.5 7.0 11	-	V
Input Leakage Current	15	V _{in} = 0 or V _{DD}	I _{in}	-	±0.1	-	±0.00001	±0.1	-	±1.0	μA
Input Capacitance	-		C _{in}	-	-	-	5.0	7.5	-	-	pF

SWITCHES IN/OUT AND COMMONS OUT/IN — W, X, Y, Z (Voltages Referenced to V_{EE})

Recommended Peak-to-Peak Voltage Into or Out of the Switch	-	Channel On or Off	V _{I/O}	0	V _{DD}	0	-	V _{DD}	0	V _{DD}	V _{p-p}
Recommended Static or Dynamic Voltage Across the Switch (Note 3) (Figure 3)	-	Channel On	ΔV _{switch}	0	600	0	-	600	0	300	mV
Output Offset Voltage	-	V _{in} = 0 V, No Load	V _{OO}	-	-	-	10	-	-	-	μV
ON Resistance	5.0 10 15	ΔV _{switch} ≤ 500 mV (Note 3), V _{in} = V _{IL} or V _{IH} (Control), and V _{in} = 0 to V _{DD} (Switch)	R _{on}	-	800 400 220	-	250 120 80	1050 500 280	-	1200 520 300	Ω
ΔON Resistance Between Any Two Channels in the Same Package	5.0 10 15		ΔR _{on}	-	70 50 45	-	25 10 10	70 50 45	-	135 95 65	Ω
Off-Channel Leakage Current (Figure 8)	15	V _{in} = V _{IL} or V _{IH} (Control) Channel to Channel or Any One Channel	I _{off}	-	±100	-	±0.05	±100	-	±1000	nA
Capacitance, Switch I/O	-	Switch Off	C _{I/O}	-	-	-	10	-	-	-	pF
Capacitance, Common O/I	-		C _{O/I}	-	-	-	17	-	-	-	pF
Capacitance, Feedthrough (Channel Off)	-	Pins Not Adjacent Pins Adjacent	C _{I/O}	-	-	-	0.15 0.47	-	-	-	pF

- Data labeled "Typ" is not to be used for design purposes, but is intended as an indication of the IC's potential performance.
- For voltage drops across the switch (ΔV_{switch}) > 600 mV (> 300 mV at high temperature), excessive V_{DD} current may be drawn; i.e. the current out of the switch may contain both V_{DD} and switch input components. The reliability of the device will be unaffected unless the Maximum Ratings are exceeded. (See first page of this data sheet.)

MC14551B

ELECTRICAL CHARACTERISTICS ($C_L = 50 \text{ pF}$, $T_A = 25^\circ\text{C}$, $V_{EE} \leq V_{SS}$)

Characteristic	Symbol	$V_{DD} - V_{EE}$ Vdc	Min	Typ (Note 4)	Max	Unit
Propagation Delay Times Switch Input to Switch Output ($R_L = 10 \text{ k}\Omega$) $t_{PLH}, t_{PHL} = (0.17 \text{ ns/pF}) C_L + 26.5 \text{ ns}$ $t_{PLH}, t_{PHL} = (0.08 \text{ ns/pF}) C_L + 11 \text{ ns}$ $t_{PLH}, t_{PHL} = (0.06 \text{ ns/pF}) C_L + 9.0 \text{ ns}$	t_{PLH}, t_{PHL}	5.0 10 15	–	35 15 12	90 40 30	ns
Control Input to Output ($R_L = 10 \text{ k}\Omega$) $V_{EE} = V_{SS}$ (Figure 4)	t_{PLH}, t_{PHL}	5.0 10 15	–	350 140 100	875 350 250	ns
Second Harmonic Distortion $R_L = 10 \text{ k}\Omega$, $f = 1 \text{ kHz}$, $V_{in} = 5 V_{p-p}$	–	10	–	0.07	–	%
Bandwidth (Figure 5) $R_L = 1 \text{ k}\Omega$, $V_{in} = 1/2 (V_{DD} - V_{EE})_{p-p}$, $20 \text{ Log } (V_{out}/V_{in}) = -3 \text{ dB}$, $C_L = 50 \text{ pF}$	BW	10	–	17	–	MHz
Off Channel Feedthrough Attenuation, Figure 5 $R_L = 1 \text{ k}\Omega$, $V_{in} = 1/2 (V_{DD} - V_{EE})_{p-p}$, $f_{in} = 55 \text{ MHz}$	–	10	–	–50	–	dB
Channel Separation (Figure 6) $R_L = 1 \text{ k}\Omega$, $V_{in} = 1/2 (V_{DD} - V_{EE})_{p-p}$, $f_{in} = 3 \text{ MHz}$	–	10	–	–50	–	dB
Crosstalk, Control Input to Common O/I, Figure 7 $R_1 = 1 \text{ k}\Omega$, $R_L = 10 \text{ k}\Omega$, Control $t_r = t_f = 20 \text{ ns}$	–	10	–	75	–	mV

4. Data labelled "Typ" is not to be used for design purposes but is intended as an indication of the IC's potential performance.

MC14551B

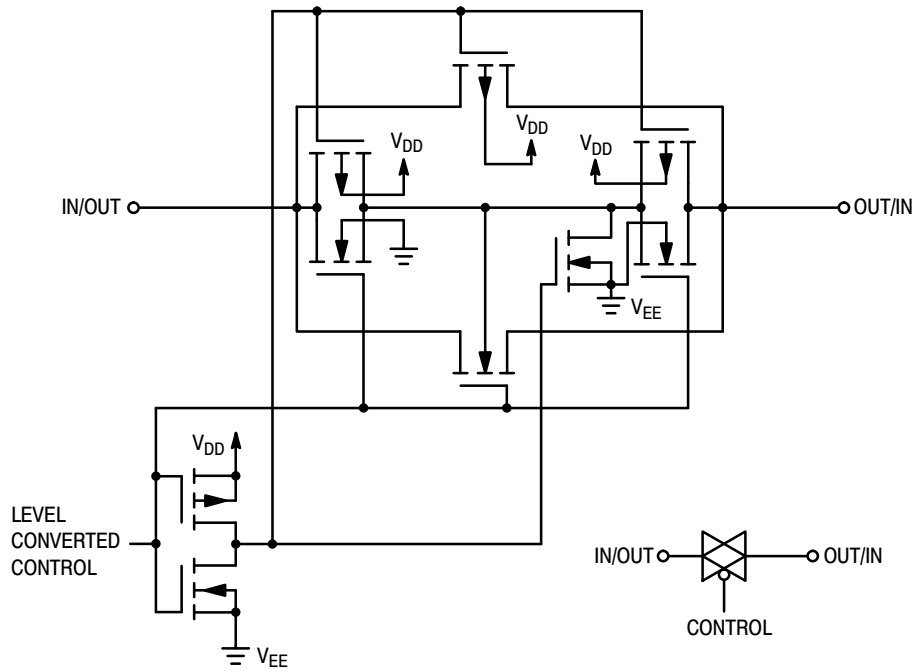

Figure 1. Switch Circuit Schematic

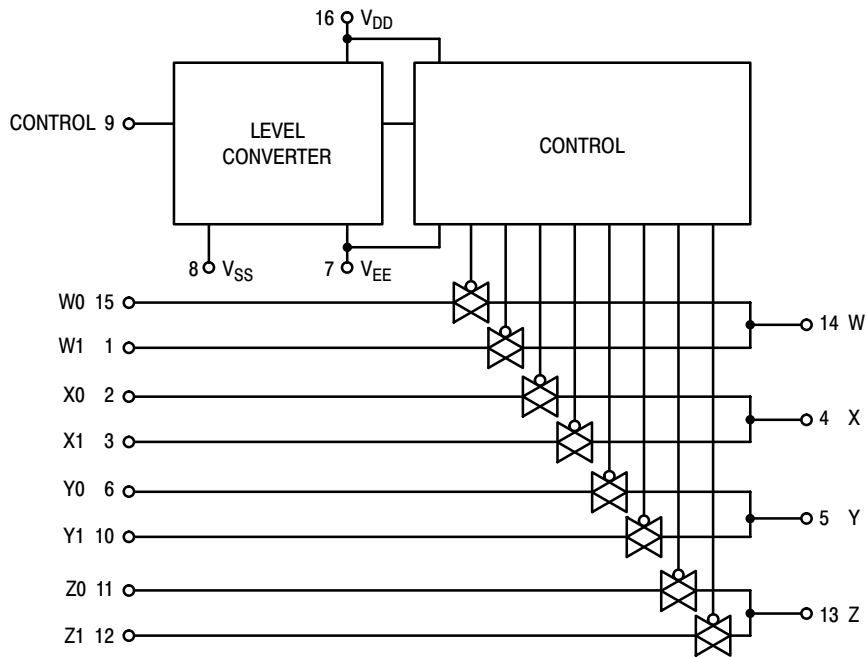

Figure 2. MC14551B Functional Diagram

MC14551B

TEST CIRCUITS

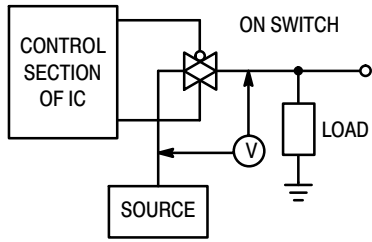

Figure 3. ΔV Across Switch

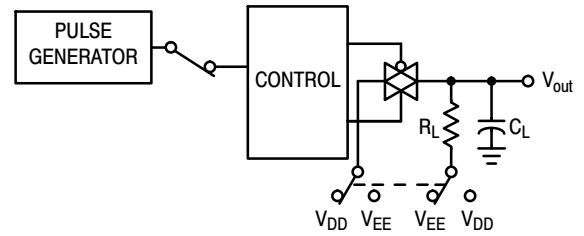

Figure 4. Propagation Delay Times, Control to Output

Control input used to turn ON or OFF the switch under test.

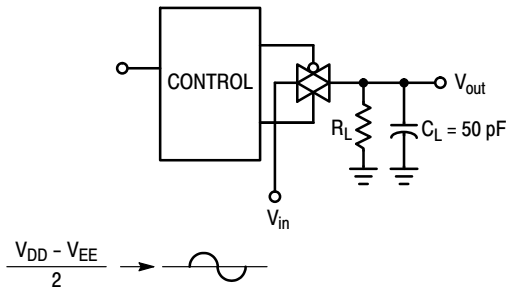

Figure 5. Bandwidth and Off-Channel Feedthrough Attenuation

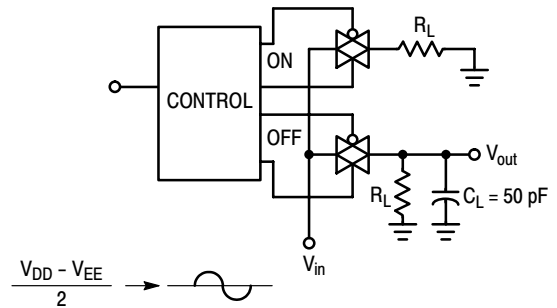

Figure 6. Channel Separation (Adjacent Channels Used for Setup)

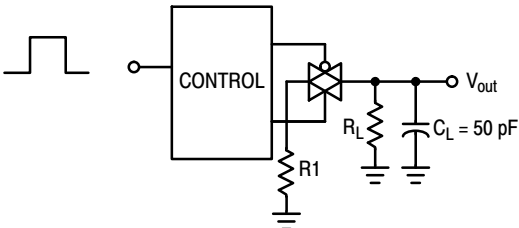

Figure 7. Crosstalk, Control Input to Common O/I

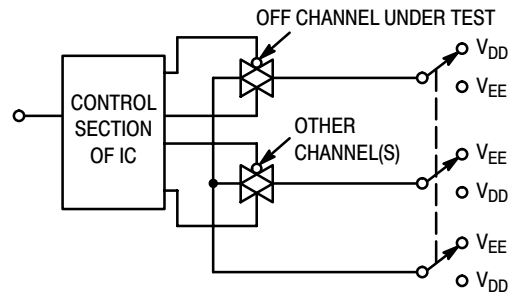

Figure 8. Off Channel Leakage

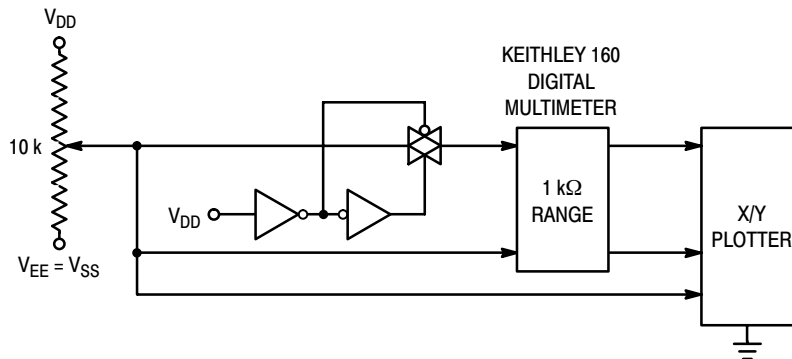

Figure 9. Channel Resistance (R_{ON}) Test Circuit

TYPICAL RESISTANCE CHARACTERISTICS

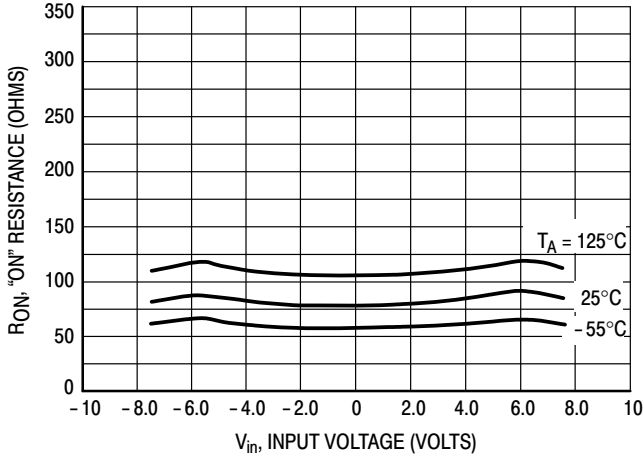

Figure 10. V_{DD} @ 7.5 V, V_{EE} @ -7.5 V

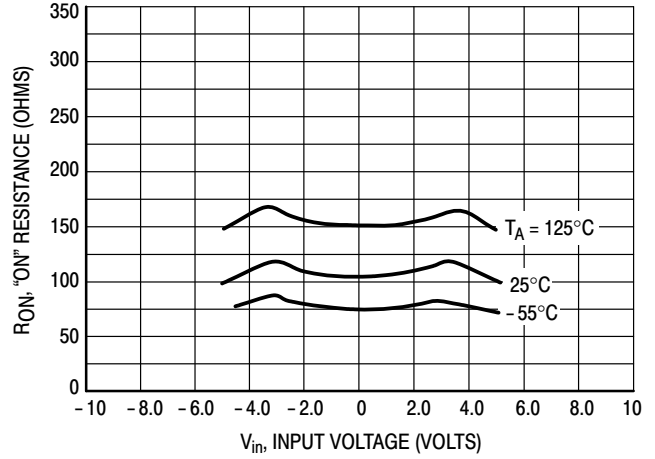

Figure 11. V_{DD} @ 5.0 V, V_{EE} @ -5.0 V

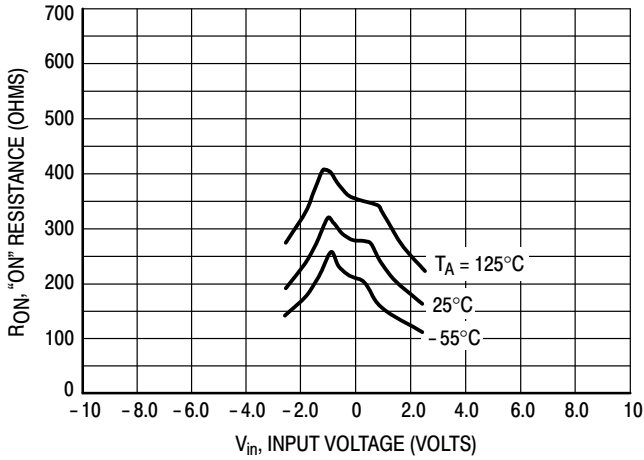

Figure 12. V_{DD} @ 2.5 V, V_{EE} @ -2.5 V

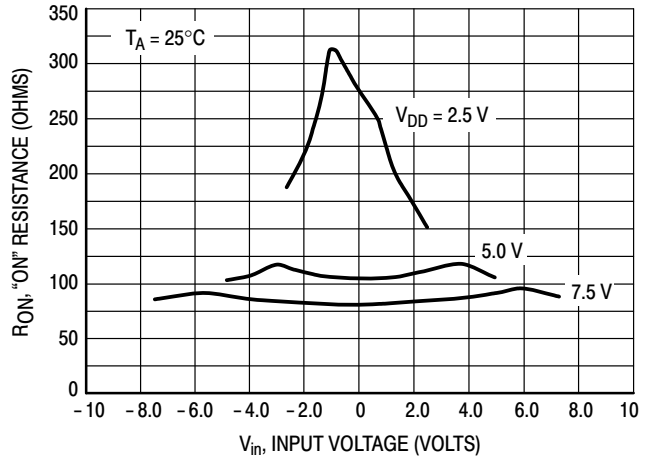

Figure 13. Comparison at 25°C, V_{DD} @ - V_{EE}

APPLICATIONS INFORMATION

Figure A illustrates use of the on-chip level converter detailed in Figure 2. The 0-to-5.0 V Digital Control signal is used to directly control a 9 V_{p-p} analog signal.

The digital control logic levels are determined by V_{DD} and V_{SS}. The V_{DD} voltage is the logic high voltage; the V_{SS} voltage is logic low. For the example, V_{DD} = +5.0 V = logic high at the control inputs; V_{SS} = GND = 0 V = logic low.

The maximum analog signal level is determined by V_{DD} and V_{EE}. The V_{DD} voltage determines the maximum recommended peak above V_{SS}. The V_{EE} voltage determines the maximum swing below V_{SS}. For the example, V_{DD} - V_{SS} = 5.0 V maximum swing above V_{SS}; V_{SS} - V_{EE} = 5.0 V maximum swing below V_{SS}. The example shows a ±4.5 V

signal which allows a 1/2 V margin at each peak. If voltage transients above V_{DD} and/or below V_{EE} are anticipated on the analog channels, external diodes (D_x) are recommended as shown in Figure B. These diodes should be small signal types able to absorb the maximum anticipated current surges during clipping.

The absolute maximum potential difference between V_{DD} and V_{EE} is 18 V. Most parameters are specified up to 15 V which is the recommended maximum difference between V_{DD} and V_{EE}.

Balanced supplies are not required. However, V_{SS} must be greater than or equal to V_{EE}. For example, V_{DD} = +10 V, V_{SS} = +5.0 V, and V_{EE} = -3.0 V is acceptable. See the table below.

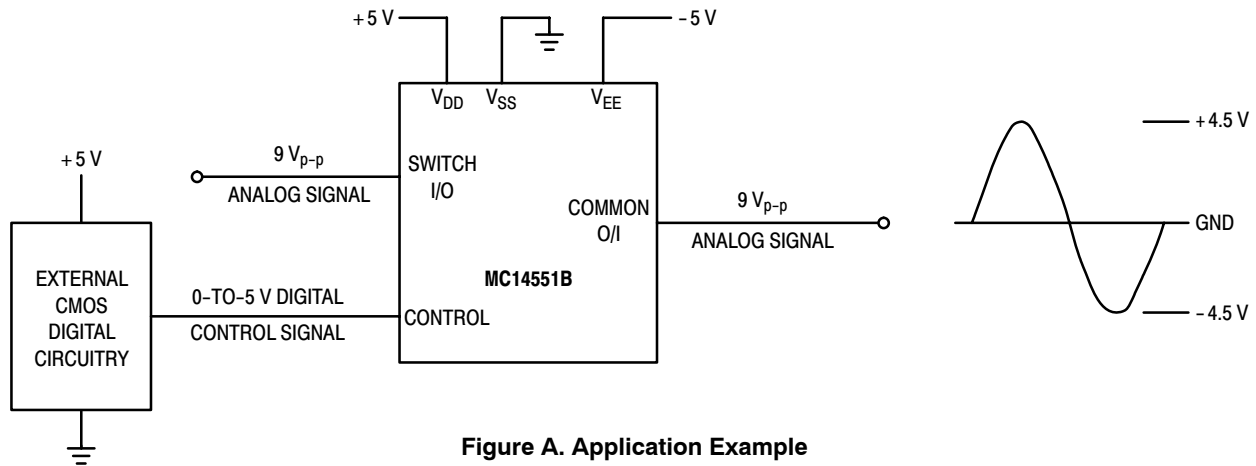

Figure A. Application Example



Figure B. External Schottky or Germanium Clipping Diodes

POSSIBLE SUPPLY CONNECTIONS

V _{DD} In Volts	V _{SS} In Volts	V _{EE} In Volts	Control Inputs Logic High/Logic Low In Volts	Maximum Analog Signal Range In Volts
+ 8	0	- 8	+ 8/0	+ 8 to - 8 = 16 V _{p-p}
+ 5	0	- 12	+ 5/0	+ 5 to - 12 = 17 V _{p-p}
+ 5	0	0	+ 5/0	+ 5 to 0 = 5 V _{p-p}
+ 5	0	- 5	+ 5/0	+ 5 to - 5 = 10 V _{p-p}
+ 10		- 5	+ 10/ + 5	+ 10 to - 5 = 15 V _{p-p}

MC14551B

PACKAGE DIMENSIONS

PDIP-16
CASE 648-08
ISSUE T

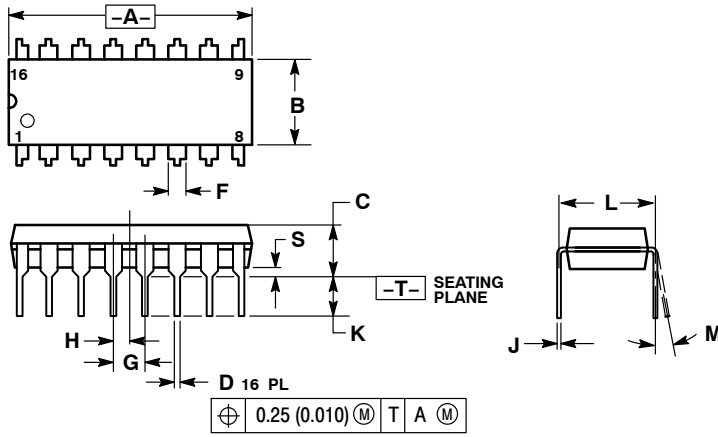

NOTES:

1. DIMENSIONING AND TOLERANCING PER ANSI Y14.5M, 1982.
2. CONTROLLING DIMENSION: INCH.
3. DIMENSION L TO CENTER OF LEADS WHEN FORMED PARALLEL.
4. DIMENSION B DOES NOT INCLUDE MOLD FLASH.
5. ROUNDED CORNERS OPTIONAL.

DIM	INCHES		MILLIMETERS	
	MIN	MAX	MIN	MAX
A	0.740	0.770	18.80	19.55
B	0.250	0.270	6.35	6.85
C	0.145	0.175	3.69	4.44
D	0.015	0.021	0.39	0.53
F	0.040	0.70	1.02	1.77
G	0.100 BSC		2.54 BSC	
H	0.050 BSC		1.27 BSC	
J	0.008	0.015	0.21	0.38
K	0.110	0.130	2.80	3.30
L	0.295	0.305	7.50	7.74
M	0°	10°	0°	10°
S	0.020	0.040	0.51	1.01

SOEIAJ-16
CASE 966-01
ISSUE A

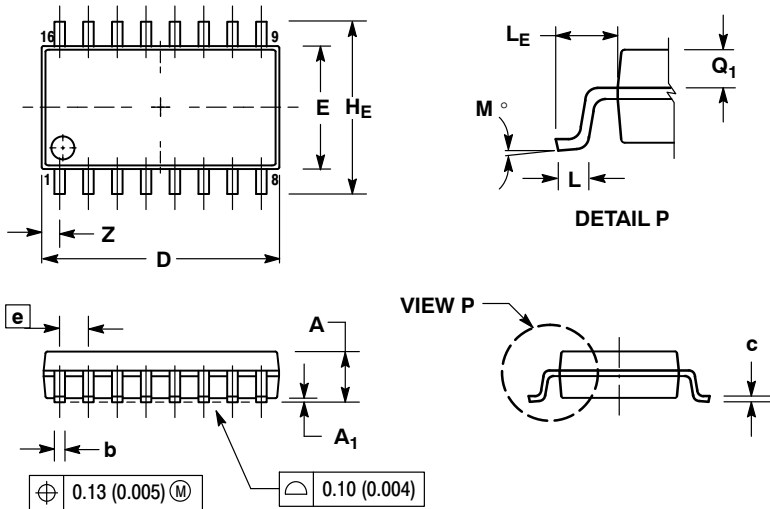

NOTES:

1. DIMENSIONING AND TOLERANCING PER ANSI Y14.5M, 1982.
2. CONTROLLING DIMENSION: MILLIMETER.
3. DIMENSIONS D AND E DO NOT INCLUDE MOLD FLASH OR PROTRUSIONS AND ARE MEASURED AT THE PARTING LINE. MOLD FLASH OR PROTRUSIONS SHALL NOT EXCEED 0.15 (0.006) PER SIDE.
4. TERMINAL NUMBERS ARE SHOWN FOR REFERENCE ONLY.
5. THE LEAD WIDTH DIMENSION (b) DOES NOT INCLUDE DAMBAR PROTRUSION. ALLOWABLE DAMBAR PROTRUSION SHALL BE 0.08 (0.003) TOTAL IN EXCESS OF THE LEAD WIDTH DIMENSION AT MAXIMUM MATERIAL CONDITION. DAMBAR CANNOT BE LOCATED ON THE LOWER RADIUS OR THE FOOT. MINIMUM SPACE BETWEEN PROTRUSIONS AND ADJACENT LEAD TO BE 0.46 (0.018).

DIM	MILLIMETERS		INCHES	
	MIN	MAX	MIN	MAX
A	---	2.05	---	0.081
A1	0.05	0.20	0.002	0.008
b	0.35	0.50	0.014	0.020
c	0.10	0.20	0.007	0.011
D	9.90	10.50	0.390	0.413
E	5.10	5.45	0.201	0.215
e	1.27 BSC		0.050 BSC	
HE	7.40	8.20	0.291	0.323
L	0.50	0.85	0.020	0.033
LE	1.10	1.50	0.043	0.059
M	0°	10°	0°	10°
Q1	0.70	0.90	0.028	0.035
Z	---	0.78	---	0.031

MC14551B

PACKAGE DIMENSIONS

SOIC-16
D SUFFIX
CASE 751B-05
ISSUE K

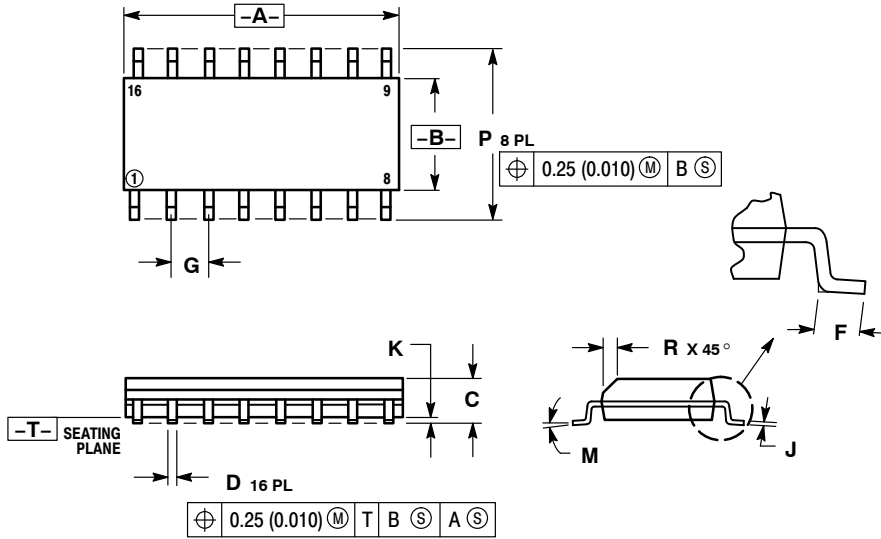

NOTES:

1. DIMENSIONING AND TOLERANCING PER ANSI Y14.5M, 1982.
2. CONTROLLING DIMENSION: MILLIMETER.
3. DIMENSIONS A AND B DO NOT INCLUDE MOLD PROTRUSION.
4. MAXIMUM MOLD PROTRUSION 0.15 (0.006) PER SIDE.
5. DIMENSION D DOES NOT INCLUDE DAMBAR PROTRUSION. ALLOWABLE DAMBAR PROTRUSION SHALL BE 0.127 (0.005) TOTAL IN EXCESS OF THE D DIMENSION AT MAXIMUM MATERIAL CONDITION.

DIM	MILLIMETERS		INCHES	
	MIN	MAX	MIN	MAX
A	9.80	10.00	0.386	0.393
B	3.80	4.00	0.150	0.157
C	1.35	1.75	0.054	0.068
D	0.35	0.49	0.014	0.019
F	0.40	1.25	0.016	0.049
G	1.27 BSC		0.050 BSC	
J	0.19	0.25	0.008	0.009
K	0.10	0.25	0.004	0.009
M	0°	7°	0°	7°
P	5.80	6.20	0.229	0.244
R	0.25	0.50	0.010	0.019

SOLDERING FOOTPRINT

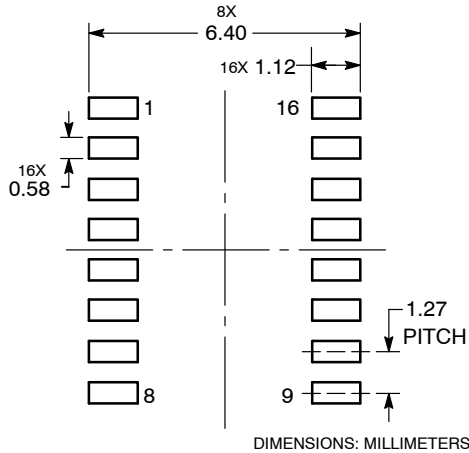

ON Semiconductor and are registered trademarks of Semiconductor Components Industries, LLC (SCILLC). SCILLC reserves the right to make changes without further notice to any products herein. SCILLC makes no warranty, representation or guarantee regarding the suitability of its products for any particular purpose, nor does SCILLC assume any liability arising out of the application or use of any product or circuit, and specifically disclaims any and all liability, including without limitation special, consequential or incidental damages. "Typical" parameters which may be provided in SCILLC data sheets and/or specifications can and do vary in different applications and actual performance may vary over time. All operating parameters, including "Typicals" must be validated for each customer application by customer's technical experts. SCILLC does not convey any license under its patent rights nor the rights of others. SCILLC products are not designed, intended, or authorized for use as components in systems intended for surgical implant into the body, or other applications intended to support or sustain life, or for any other application in which the failure of the SCILLC product could create a situation where personal injury or death may occur. Should Buyer purchase or use SCILLC products for any such unintended or unauthorized application, Buyer shall indemnify and hold SCILLC and its officers, employees, subsidiaries, affiliates, and distributors harmless against all claims, costs, damages, and expenses, and reasonable attorney fees arising out of, directly or indirectly, any claim of personal injury or death associated with such unintended or unauthorized use, even if such claim alleges that SCILLC was negligent regarding the design or manufacture of the part. SCILLC is an Equal Opportunity/Affirmative Action Employer. This literature is subject to all applicable copyright laws and is not for resale in any manner.

PUBLICATION ORDERING INFORMATION

LITERATURE FULFILLMENT:
Literature Distribution Center for ON Semiconductor
P.O. Box 5163, Denver, Colorado 80217 USA
Phone: 303-675-2175 or 800-344-3860 Toll Free USA/Canada
Fax: 303-675-2176 or 800-344-3867 Toll Free USA/Canada
Email: orderlit@onsemi.com

N. American Technical Support: 800-282-9855 Toll Free USA/Canada
Europe, Middle East and Africa Technical Support:
Phone: 421 33 790 2910
Japan Customer Focus Center
Phone: 81-3-5773-3850

ON Semiconductor Website: www.onsemi.com
Order Literature: <http://www.onsemi.com/orderlit>
For additional information, please contact your local Sales Representative

Компания «Океан Электроники» предлагает заключение долгосрочных отношений при поставках импортных электронных компонентов на взаимовыгодных условиях!

Наши преимущества:

- Поставка оригинальных импортных электронных компонентов напрямую с производств Америки, Европы и Азии, а так же с крупнейших складов мира;
- Широкая линейка поставок активных и пассивных импортных электронных компонентов (более 30 млн. наименований);
- Поставка сложных, дефицитных, либо снятых с производства позиций;
- Оперативные сроки поставки под заказ (от 5 рабочих дней);
- Экспресс доставка в любую точку России;
- Помощь Конструкторского Отдела и консультации квалифицированных инженеров;
- Техническая поддержка проекта, помощь в подборе аналогов, поставка прототипов;
- Поставка электронных компонентов под контролем ВП;
- Система менеджмента качества сертифицирована по Международному стандарту ISO 9001;
- При необходимости вся продукция военного и аэрокосмического назначения проходит испытания и сертификацию в лаборатории (по согласованию с заказчиком);
- Поставка специализированных компонентов военного и аэрокосмического уровня качества (Xilinx, Altera, Analog Devices, Intersil, Interpoint, Microsemi, Actel, Aeroflex, Peregrine, VPT, Syfer, Eurofarad, Texas Instruments, MS Kennedy, Miteq, Cobham, E2V, MA-COM, Hittite, Mini-Circuits, General Dynamics и др.);

Компания «Океан Электроники» является официальным дистрибьютором и эксклюзивным представителем в России одного из крупнейших производителей разъемов военного и аэрокосмического назначения «JONHON», а так же официальным дистрибьютором и эксклюзивным представителем в России производителя высокотехнологичных и надежных решений для передачи СВЧ сигналов «FORSTAR».



JONHON

«JONHON» (основан в 1970 г.)

Разъемы специального, военного и аэрокосмического назначения:

(Применяются в военной, авиационной, аэрокосмической, морской, железнодорожной, горно- и нефтедобывающей отраслях промышленности)

«FORSTAR» (основан в 1998 г.)

ВЧ соединители, коаксиальные кабели, кабельные сборки и микроволновые компоненты:

(Применяются в телекоммуникациях гражданского и специального назначения, в средствах связи, РЛС, а так же военной, авиационной и аэрокосмической отраслях промышленности).



Телефон: 8 (812) 309-75-97 (многоканальный)

Факс: 8 (812) 320-03-32

Электронная почта: ocean@oceanchips.ru

Web: <http://oceanchips.ru/>

Адрес: 198099, г. Санкт-Петербург, ул. Калинина, д. 2, корп. 4, лит. А