



MAX9724A Evaluation Kit

General Description

The MAX9724A evaluation kit (EV kit) is a fully assembled and tested printed-circuit board (PCB) that uses the MAX9724A IC to drive a stereo headphone in portable applications. The MAX9724A is a 60mW stereo headphone amplifier with adjustable gain and DirectDrive™ outputs. Maxim's DirectDrive technology eliminates the need for bulky DC-blocking capacitors at the output of the amplifier.

The EV kit is configured for a -1.5V/V gain and is designed to operate from a 2.7V to 5.5V DC power supply. The EV kit is capable of delivering up to 60mW per channel into a 32Ω load and achieving 0.02% THD+N.

The MAX9724A EV kit can also be used to evaluate the MAX9724B fixed-gain amplifier. Contact Maxim for a free sample of the MAX9724B IC.

Features

- ◆ No DC-Blocking Output Capacitors Required
- ◆ 2.7V to 5.5V Operation
- ◆ Adjustable -1.5V/V Gain
- ◆ 60mW per Channel into a 32Ω Load
- ◆ 0.02% THD+N
- ◆ Fully Assembled and Tested

Ordering Information

PART	TYPE
MAX9724AEVKIT+	EV Kit

+ Denotes lead-free and RoHS-compliant.

Component List

DESIGNATION	QTY	DESCRIPTION
C1, C2, C4	3	1μF ±10%, 10V X5R ceramic capacitors (0603) Murata GRM188R61A105K
C3	1	0.1μF ±10%, 10V X5R ceramic capacitor (0402) Murata GRM155R61A104K
C5, C6	2	0.47μF ±10%, 10V X5R ceramic capacitors (0603) Murata GRM188R61A474K
JU1	1	3-pin header
OUT	1	Stereo headphone jack (3.5mm)

DESIGNATION	QTY	DESCRIPTION
OUTL, OUTR, SGND	0	Not installed, test points
R1, R3	2	10kΩ ±1% resistors (0603)
R2, R4	2	15kΩ ±1% resistors (0603)
U1	1	60mW, DirectDrive, stereo headphone amplifier (12-pin TQFN-EP*) Maxim MAX9724AETC+
—	1	Shunt (JU1)
—	1	PCB: MAX9724A Evaluation Kit+

*EP = Exposed paddle.

Component Supplier

SUPPLIER	PHONE	WEBSITE
Murata Mfg. Co., Ltd.	770-436-1300	www.murata.com

Note: Indicate that you are using the MAX9724A when contacting this component supplier.

MAX9724A Evaluation Kit

Quick Start

Required Equipment

Before beginning, the following equipment is needed:

- 2.7V to 5.5V, 500mA power supply
- 32Ω stereo headphones with a 3.5mm plug
- Audio signal source

Procedure

The MAX9724A EV kit is fully assembled and tested. Follow the steps below to verify board operation.

Caution: Do not turn on the power supply until all connections are completed.

- 1) Verify that a shunt is installed on jumper JU1, pins 2-3 (IC disabled).
- 2) Set the power-supply output to 5V.
- 3) Disable the power-supply output.
- 4) Connect the power-supply ground to the PGND pad and the power-supply positive output to the VDD pad.
- 5) Verify that the audio source output is disabled.
- 6) Connect the audio source ground, left signal, and right signal to the SGND, INL, and INR pads, respectively.
- 7) Plug the headphone into the OUT headphone jack.
- 8) Enable the power-supply output.
- 9) Enable the audio source.
- 10) Install a shunt on jumper JU1 across pins 1-2 (IC enabled).
- 11) Verify that the headphones are playing the audio source signal.

Detailed Description

The MAX9724A EV kit features the MAX9724A IC stereo headphone amplifier. The MAX9724A features adjustable gain and 60mW DirectDrive outputs. DirectDrive generates an internal negative supply (-VDD) from the positive supply (VDD), thus biasing the amplifier output. Zero-voltage biasing eliminates the need for bulky DC-blocking capacitors at the amplifier output. The MAX9724A operates from a 2.7V to 5.5V supply with a low quiescent current of 3.5mA. The MAX9724A comes in a 12-pin thin QFN package suitable for portable applications.

The EV kit's gain for each channel is set to -1.5V/V. The left- and right-channel gain can be adjusted by modifying the ratio of the corresponding gain-setting resistors R1–R4. R1 and R2 set the right-channel gain and R3 and R4 set the left-channel gain. The IC delivers up to 60mW per channel into a 32Ω load while achieving 0.02% THD+N.

Test points OUTR, OUTL, and SGND are provided to easily measure the output signals.

The MAX9724A EV kit can evaluate the fixed-gain MAX9724B IC, also in a 12-pin thin QFN package. The MAX9724B features a fixed gain of -1.5V/V. See the *Evaluating the MAX9724B* section for more information.

Shutdown ($\overline{\text{SHDN}}$)

Jumper JU1 controls the shutdown pin ($\overline{\text{SHDN}}$) of the MAX9724A that enables and disables the MAX9724A IC. See Table 1 for jumper JU1 configurations.

Table 1. Jumper JU1 Shutdown Selection

SHUNT POSITION	$\overline{\text{SHDN}}$ PIN	MAX9724A FUNCTION
1-2	Connected to VDD	Enabled
2-3	Connected to GND	Disabled

Gain Setting

The default gain-setting resistors R1–R4 configure the gain for both the left and right channels to -1.5V/V. The gain can be changed by replacing these resistors with other surface-mount 0603 resistors. Resistors with a tolerance of 1% or better are recommended for optimum performance. Use Table 2 and the following equation to select new gain-setting resistors for the corresponding channel.

Table 2. Gain-Setting Resistors

CHANNEL	RIN	RF
Right	R1	R2
Left	R3	R4

$$RF = -A \cdot RIN$$

where $RIN \geq 10k\Omega$ and A is the desired negative gain. Refer to the *Output Dynamic Range* and *Maximum Output Swing* sections in the MAX9724A/MAX9724B IC data sheet for limitations on setting the gain.

Evaluating the MAX9724B

The MAX9724A EV kit can evaluate the fixed-gain MAX9724B IC after performing the following:

- 1) Replace U1 with the MAX9724B IC.
- 2) Remove resistors R2 and R4.
- 3) Replace resistors R1 and R3 with 0Ω 0603 surface-mount resistors.

The MAX9724B features a fixed-gain of -1.5V/V. Contact Maxim for a free sample of the MAX9724BETC+.

MAX9724A Evaluation Kit

Evaluates: MAX9724A/MAX9724B

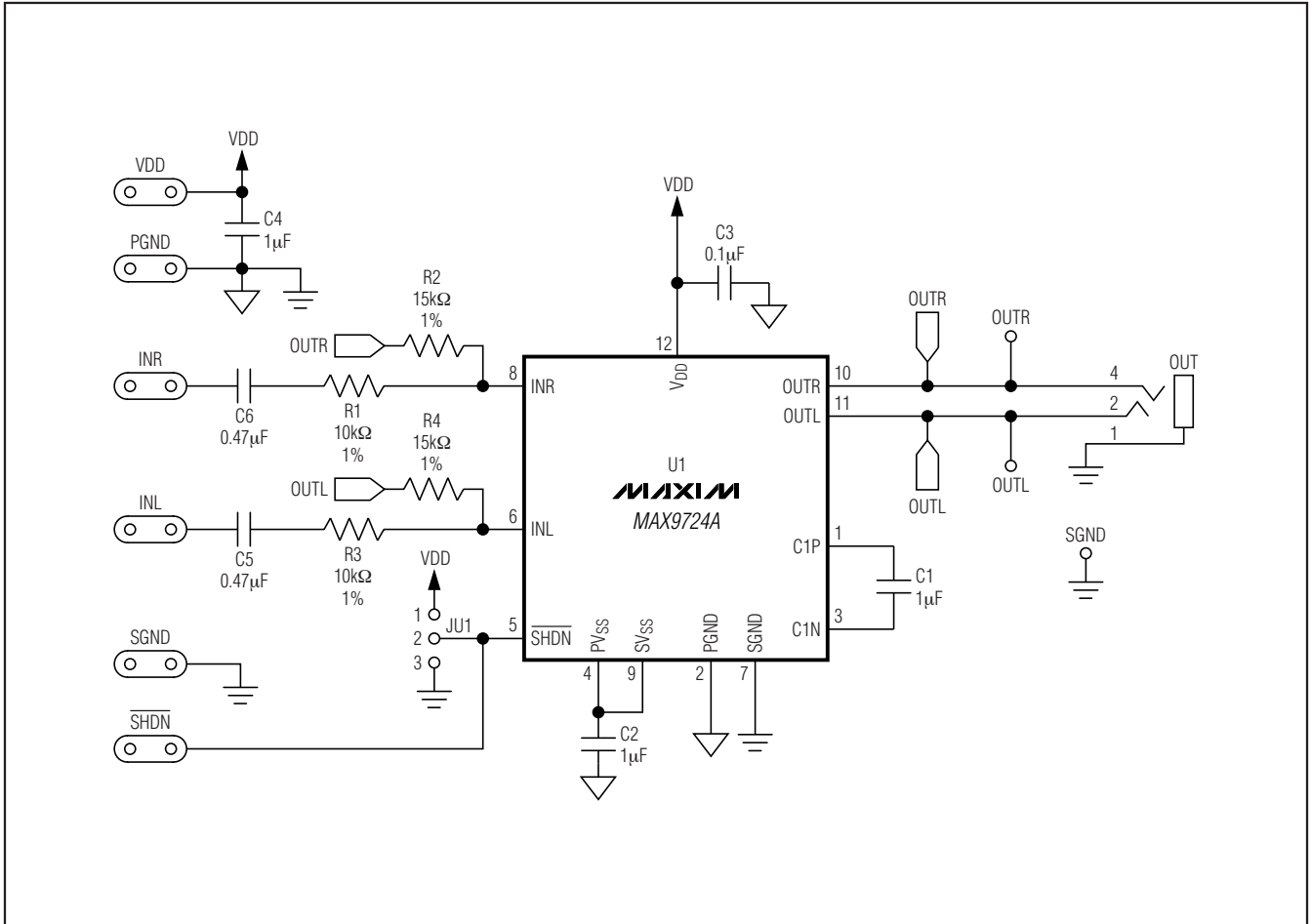

Figure 1. MAX9724A EV Kit Schematic

MAX9724A Evaluation Kit

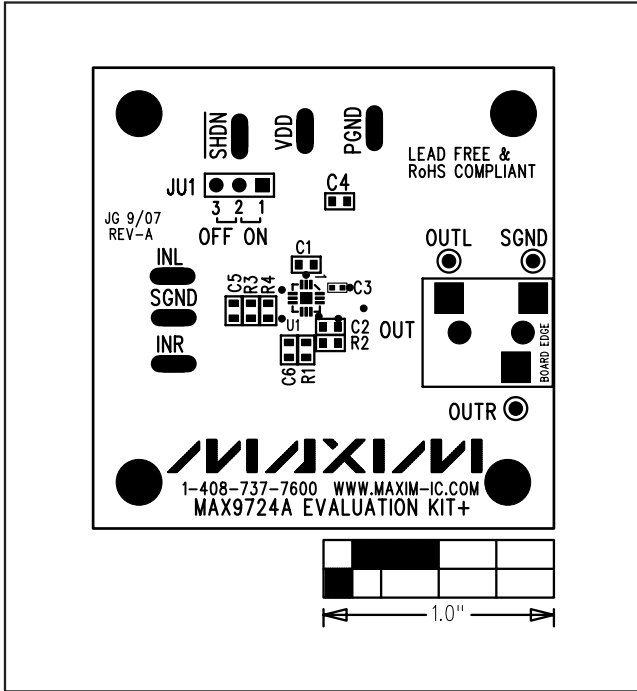

Figure 2. MAX9724A EV Kit Component Placement Guide—Component Side

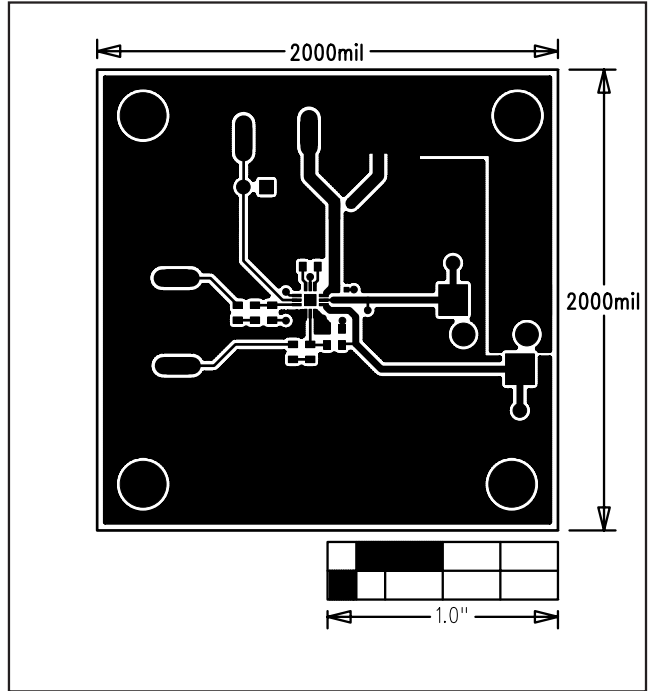

Figure 3. MAX9724A EV Kit PCB Layout—Component Side

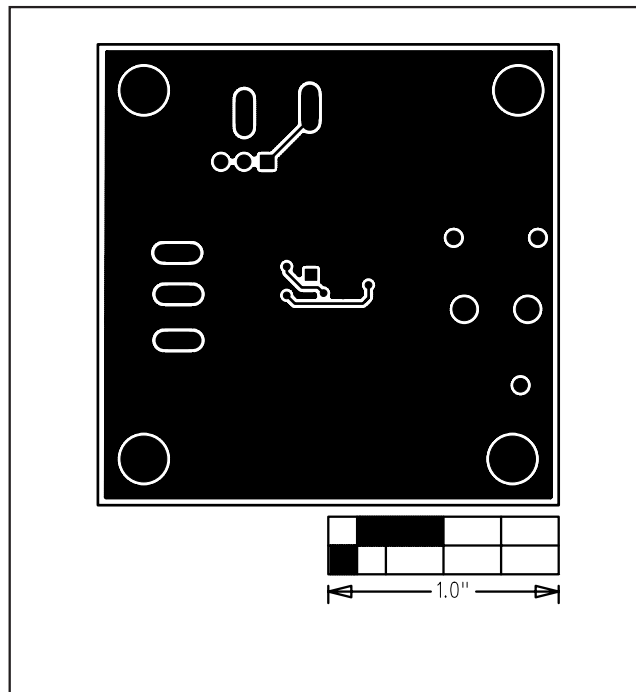

Figure 4. MAX9724A EV Kit PCB Layout—Solder Side

Maxim cannot assume responsibility for use of any circuitry other than circuitry entirely embodied in a Maxim product. No circuit patent licenses are implied. Maxim reserves the right to change the circuitry and specifications without notice at any time.

4 _____ **Maxim Integrated Products, 120 San Gabriel Drive, Sunnyvale, CA 94086 408-737-7600**

Компания «Океан Электроники» предлагает заключение долгосрочных отношений при поставках импортных электронных компонентов на взаимовыгодных условиях!

Наши преимущества:

- Поставка оригинальных импортных электронных компонентов напрямую с производств Америки, Европы и Азии, а так же с крупнейших складов мира;
- Широкая линейка поставок активных и пассивных импортных электронных компонентов (более 30 млн. наименований);
- Поставка сложных, дефицитных, либо снятых с производства позиций;
- Оперативные сроки поставки под заказ (от 5 рабочих дней);
- Экспресс доставка в любую точку России;
- Помощь Конструкторского Отдела и консультации квалифицированных инженеров;
- Техническая поддержка проекта, помощь в подборе аналогов, поставка прототипов;
- Поставка электронных компонентов под контролем ВП;
- Система менеджмента качества сертифицирована по Международному стандарту ISO 9001;
- При необходимости вся продукция военного и аэрокосмического назначения проходит испытания и сертификацию в лаборатории (по согласованию с заказчиком);
- Поставка специализированных компонентов военного и аэрокосмического уровня качества (Xilinx, Altera, Analog Devices, Intersil, Interpoint, Microsemi, Actel, Aeroflex, Peregrine, VPT, Syfer, Eurofarad, Texas Instruments, MS Kennedy, Miteq, Cobham, E2V, MA-COM, Hittite, Mini-Circuits, General Dynamics и др.);

Компания «Океан Электроники» является официальным дистрибьютором и эксклюзивным представителем в России одного из крупнейших производителей разъемов военного и аэрокосмического назначения «JONHON», а так же официальным дистрибьютором и эксклюзивным представителем в России производителя высокотехнологичных и надежных решений для передачи СВЧ сигналов «FORSTAR».



JONHON

«JONHON» (основан в 1970 г.)

Разъемы специального, военного и аэрокосмического назначения:

(Применяются в военной, авиационной, аэрокосмической, морской, железнодорожной, горно- и нефтедобывающей отраслях промышленности)

«FORSTAR» (основан в 1998 г.)

ВЧ соединители, коаксиальные кабели, кабельные сборки и микроволновые компоненты:

(Применяются в телекоммуникациях гражданского и специального назначения, в средствах связи, РЛС, а так же военной, авиационной и аэрокосмической отраслях промышленности).



Телефон: 8 (812) 309-75-97 (многоканальный)

Факс: 8 (812) 320-03-32

Электронная почта: ocean@oceanchips.ru

Web: <http://oceanchips.ru/>

Адрес: 198099, г. Санкт-Петербург, ул. Калинина, д. 2, корп. 4, лит. А