

FB-2SP/24DC

Modular fieldbus device coupler

Data sheet
3237_en_A

© PHOENIX CONTACT 2015-01-12



1 Description

The fieldbus device coupler is suitable for Foundation Fieldbus™ and PROFIBUS PA. It provides an interface between the fieldbus trunk cable and field devices. Limited width on the rail reduces the required footprint and weight of the field enclosure.

The FB-2SP/24DC coupler features short-circuit protection with an additional voltage-limitation circuit. The voltage-limitation circuit allows the connection of spurs and end devices in an Ex nA ic hazardous location. Utilizing the FB-2SP/24DC coupler, a fieldbus power supply with voltage limitation of 24 V DC is not required. The FB-2SP/24DC coupler is powered and communicates through the included ME 17,5 TBUS... connector installed on the DIN rail.

The FB-2SP/24DC is hot-swappable and scalable in the safe area or with a gas clearance. The single-sided plug configuration makes wiring in a field enclosure easy and increases reliability by not compromising cable bend radius. These couplers may be installed in a common field enclosure.

Diagnostic LEDs include DC OK and spur fault.

Connection to an FB-ET/E module is required and makes the connection from the trunk to the FB-2SP/24DC. The FB-ET/E includes a preinstalled external terminator, ensuring termination is always available. A shield-to-earth select switch is also provided.



Make sure you always use the latest documentation. It can be downloaded at phoenixcontact.com.



This data sheet is valid for all products listed on the following page:

2 Ordering data

Products

Description	Type	Order No.	Pcs. / Pkt.
Device coupler, two-spur, voltage and current limiting for ic hazardous locations, includes T-BUS connector	FB-2SP/24DC	2316352	1

Accessories

Description	Type	Order No.	Pcs. / Pkt.
Device coupler, trunk module, external terminator, includes T-BUS connector	FB-ET/E	2316050	1
Power supply plug, 28 V DC, 500 mA	FB-PS-PLUG-24DC/28DC/0.5/EX	2316132	1
Power supply base	FB-PS-BASE/EX	2316145	1
Surge protective plug, for floating signal circuit	PT 2X2-FF-ST	2800755	10
Base element, for four signal lines with floating ground	PT 4+F-BE	2839415	10
Diagnostic coupler, modular installation, includes T-BUS connector	FB-DIAG/FF/NC	2316297	1
Enclosure, 15 ports, aluminum	FB-15-AL	2316187	1
Enclosure, 15 ports, stainless steel	FB-15-SS	2316190	1
Enclosure, 8 ports, aluminum	FB-8-AL	2316200	1
Enclosure, 9 ports, stainless steel	FB-9-SS	2316213	1

3 Technical data

General data

Number of spurs per module	2
Number of spurs per segment	24
Degree of protection	IP20
Ambient temperature (operation)	-40...85°C
Ambient temperature (storage/transport)	-40...85°C
Permissible humidity (operation)	95%, non-condensing
Flammability rating, UL94	V0
Mounting	On horizontal DIN rail in accordance with EN 60715
Weight	58 g
Connection type	Screw terminals, removable for each spur
Conductor cross-section (solid/stranded/AWG)	0.5...2.5 mm ² /0.5...2.5 mm ² /24...12)

Electrical data

Supply voltage, minimum (from FB-ET/E)	10.5 V DC
Supply voltage, maximum (from FB-ET/E)	30.0 V DC
Rated current, trunk in to T-BUS (from FB-ET/E)	≤1.0 A
Current consumption, no load	4.5 mA
Power dissipation, maximum, at maximum load and voltage	0.5 W
Rated voltage, per spur	≤24.0 V
Current draw per spur device, maximum	35 mA
Current draw of all spur devices, maximum	50 mA
Short-circuit current, maximum, on spur	45 mA

Hazardous location ratings

Temperature, T_a	-40...85°C
Voltage, U_o	23.56 V DC
Current, I_o	40.9 mA
Power, P_o	0.964 W
Capacitance, C_i	0 nF
Inductance, L_i	4 μ H
Capacitance, C_o	60 nF
Inductance, L_o	250 μ H

Conformance

Shock resistance	30g, 11 ms
Vibration resistance	5g, 10...50 Hz
Fieldbus Foundation	FF-846
NE	NE21
IEC	IEC 60079-0:2011, IEC 60079-15:2010, IEC 60079-11:2011 IEC 60529, IEC 61158-2
EN	EN 61326, EN 60068-2-27, EN 60068-2-6, EN 60079-0, EN 60079-11, EN60079-15

Approvals

ATEX	Sira 13ATEX4016X II 3(3)G; Ex nA [ic] IIC T4 Gc
IECEX	IECEX SIR 13.0001X Ex nA [ic] IIC T4 Gc
CSA (C/US)	Class I, Div. 2, Groups A, B, C, D; Ex nA[ic] IIC T4 Gc Class I, Zone 2; AEx nA[ic] IIC T4 Gc

4 Dimensions

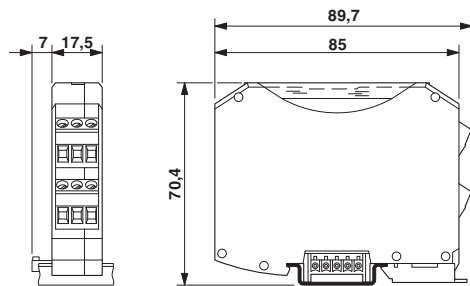

Figure 1 FB-2SP/24DC dimensions

5 Schematic

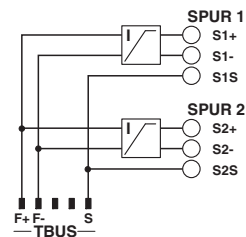

Figure 2 FB-2SP/24DC circuit diagram

6 Installation

6.1 Mounting

The modules are installed using DIN rail and ME 17,5 TBUS... (included) connectors.

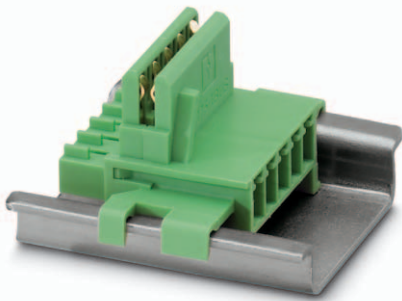

Figure 3 ME 17,5 TBUS... connector

1. Secure the mounting rail to an appropriate surface and position the ME 17,5 TBUS... connectors within the rail, ensuring that all connectors are oriented properly.



When grounding the shield, the ground connection is through the FB-ET/E module to the DIN rail. This requires the DIN rail to also be grounded.

2. If desired, connect the DIN rail to a ground.

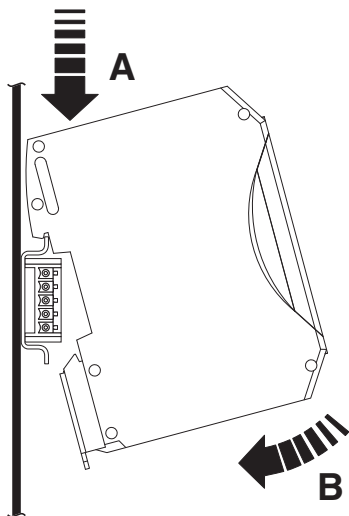

Figure 4 DIN rail mounting

3. Place the module onto the DIN rail from above. The upper holding keyway must be hooked onto the top edge of the DIN rail.

4. Push the module from the front toward the mounting surface, making sure to align the module with the ME 17,5 TBUS... connector.

6.2 Removal

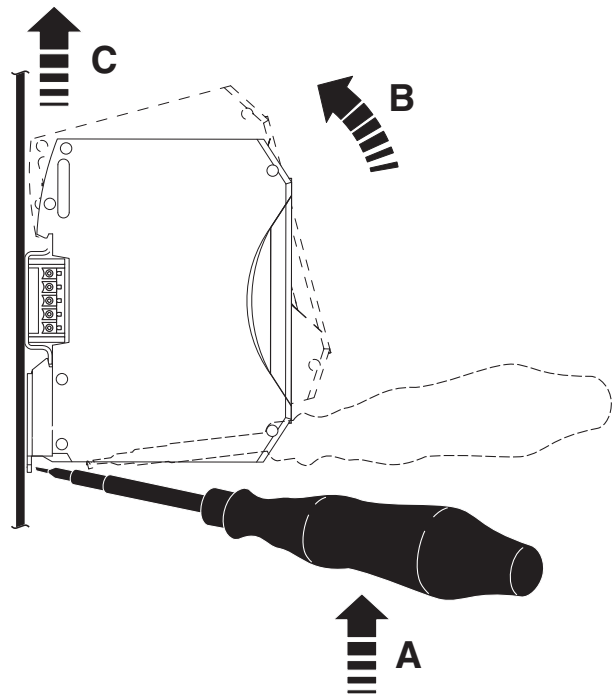

Figure 5 DIN rail removal

1. Insert a suitable tool (e.g., needle-nose pliers) into the arresting latch and pull it down.
2. Pull the module slightly away from the mounting surface by rotating it upward.
3. Lift the module from the rail.

7 Connections

Foundation Fieldbus and PROFIBUS PA network configurations are bus-type networks. Each device coupler includes removable connectors. Table 1 shows the trunk and spur connections.



NOTE:
Only one device can be connected to each spur.

Table 1 Connections

Connection	Label	Function
Spur	<i>SnS</i>	Spur <i>n</i> shield ¹
	<i>Sn-</i>	Spur <i>n</i> -
	<i>Sn+</i>	Spur <i>n</i> +

¹ *n* indicates the spur number. Couplers may have multiple spur connectors.

8 Maintenance

8.1 LEDs

LEDs on each module indicate operating status.

Table 2 FB-2SP24DC LEDs

Item	Label	Color	Function
1	PWR	Green	On indicates power >18 V
2	ERR1	Red	On indicates a short on spur 1
3	ERR2	Red	On indicates a short on spur 2

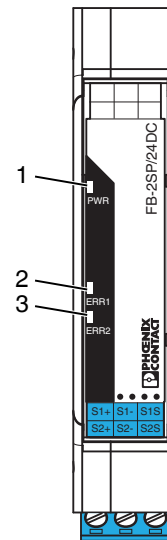

Figure 6 LEDs

Компания «Океан Электроники» предлагает заключение долгосрочных отношений при поставках импортных электронных компонентов на взаимовыгодных условиях!

Наши преимущества:

- Поставка оригинальных импортных электронных компонентов напрямую с производств Америки, Европы и Азии, а так же с крупнейших складов мира;
- Широкая линейка поставок активных и пассивных импортных электронных компонентов (более 30 млн. наименований);
- Поставка сложных, дефицитных, либо снятых с производства позиций;
- Оперативные сроки поставки под заказ (от 5 рабочих дней);
- Экспресс доставка в любую точку России;
- Помощь Конструкторского Отдела и консультации квалифицированных инженеров;
- Техническая поддержка проекта, помощь в подборе аналогов, поставка прототипов;
- Поставка электронных компонентов под контролем ВП;
- Система менеджмента качества сертифицирована по Международному стандарту ISO 9001;
- При необходимости вся продукция военного и аэрокосмического назначения проходит испытания и сертификацию в лаборатории (по согласованию с заказчиком);
- Поставка специализированных компонентов военного и аэрокосмического уровня качества (Xilinx, Altera, Analog Devices, Intersil, Interpoint, Microsemi, Actel, Aeroflex, Peregrine, VPT, Syfer, Eurofarad, Texas Instruments, MS Kennedy, Miteq, Cobham, E2V, MA-COM, Hittite, Mini-Circuits, General Dynamics и др.);

Компания «Океан Электроники» является официальным дистрибьютором и эксклюзивным представителем в России одного из крупнейших производителей разъемов военного и аэрокосмического назначения «JONHON», а так же официальным дистрибьютором и эксклюзивным представителем в России производителя высокотехнологичных и надежных решений для передачи СВЧ сигналов «FORSTAR».



JONHON

«JONHON» (основан в 1970 г.)

Разъемы специального, военного и аэрокосмического назначения:

(Применяются в военной, авиационной, аэрокосмической, морской, железнодорожной, горно- и нефтедобывающей отраслях промышленности)

«FORSTAR» (основан в 1998 г.)

ВЧ соединители, коаксиальные кабели, кабельные сборки и микроволновые компоненты:

(Применяются в телекоммуникациях гражданского и специального назначения, в средствах связи, РЛС, а так же военной, авиационной и аэрокосмической отраслях промышленности).



Телефон: 8 (812) 309-75-97 (многоканальный)

Факс: 8 (812) 320-03-32

Электронная почта: ocean@oceanchips.ru

Web: <http://oceanchips.ru/>

Адрес: 198099, г. Санкт-Петербург, ул. Калинина, д. 2, корп. 4, лит. А