

LTC5587

6GHz RMS Power Detector with 12-bit Digital Output

DESCRIPTION

Demonstration circuit 1638A is a Mean-Squared Power Detector with integrated 12-bit ADC featuring the LTC[®]5587 IC.

The LTC5587 is a wide dynamic range Mean Squared RF Power Detector, operational from 10MHz to 6GHz, with sample rate up to 500ksps. The input dynamic range at 2.14GHz, with ± 1 dB nonlinearity, is 40dB (from -34 dBm to $+6$ dBm, single-ended 50 Ω input). The detector output, V_{OUT} is also the input to the internal ADC, the digital output slope is typically 70LSB/dB, and the typical output variation over temperature is ± 1 dB at 2.14GHz.

LTC5587 has the internal 12-bit SPI compatible ADC. DC1638A demonstrates the performance in conjunction with DC590B Quick-Eval board. The DC590B board samples the ADC at approximately 200Hz. Faster sampling rate is possible, contact LTC applications for more information.

The 1638A Demo Circuit input is optimized for wide frequency range of 1.75GHz to 2.2GHz. However, input match can be shifted down to 10MHz or up to 6GHz with simple external matching.

Design files for this demo board are available. Call the LTC factory.

LTC is a trademark of Linear Technology Corporation

Typical Performance Summary ($V_{CC} = V_{DD} = 0V_{DD} = 3.3V$, $V_{EN} = 3.3V$, $V_{REF} = 1.8V$, $V_{OUT} = \text{ADC OUTPUT(LSB)} * 1.8/4096$, $T_A = 25^\circ\text{C}$, unless otherwise noted. Test circuit shown in Figure 1.)

PARAMETER	CONDITION	TYPICAL VALUE
$0V_{DD}$ Supply Voltage		1.0 to V_{DD}
V_{DD} Supply Voltage		2.7V to 3.6V
V_{CC} Supply Voltage	Should be equal to V_{DD}	2.7V to 3.6V
V_{REF} Reference Voltage		1.4 to $V_{DD} + 0.05V$
Total Supply Current	No RF input signal, ADC operational at 500ksps	3mA
Shutdown Current	$V_{EN} = 0.3V$, $CONV = 3.3V$, ADC Sleep-Mode	0.2 μ A
EN Voltage	Low, Chip Disabled HIGH, Chip Enabled	0.3V max 2V min
EN Input Current	$V_{EN} = 0V$ $V_{EN} = 3.3V$	0 μ A 20 μ A
Output Detector Voltage, V_{OUT}	No Input Signal Present	0.18V
Rise Time(1000pF on V_{OUT})	0.2V to 1.6V, 10% to 90%, $F_{RF} = 2140$ MHz	1 μ s
Fall Time(1000pF on V_{OUT})	1.6V to 0.2V, 90% to 10%, $F_{RF} = 2140$ MHz	8 μ s
Input Frequency Range	With external matching components	10MHz to 6GHz
f = 880MHz		
RF Input Power Range	CW input: Externally Matched to 50 Ω Source	-34 to 6 dBm
Linear Dynamic Range, CW	± 1 dB linearity error	40 dB
Output Slope		73LSB/dB
Logarithmic Intercept		-42dBm

Output Variation vs Temperature	$P_{IN} = -34$ to $+6$ dBm	± 1 dB
Deviation from CW Response	EDGE $3\pi/8$ Shifted 8PSK, $P_{IN} = -34$ to $+6$ dBm	± 0.1 dB
f = 2140MHz		
RF Input Power Range	CW input: Externally Matched to 50Ω Source	-34 to 6 dBm
Linear Dynamic Range, CW	± 1 dB linearity error	43 dB
Output Slope		73 LSB/dB
Logarithmic Intercept		-42dBm
Output Variation vs Temperature	$P_{IN} = -34$ to $+6$ dBm	± 1 dB
Deviation from CW Response	12 dB peak-to-average ratio (4 carrier WCDMA)	± 0.5 dB
F=3500MHz		
Linear Dynamic Range, CW	± 1 dB linearity error	36dB
Slope		73LSB/dB
Logarithmic Intercept		-40dBm
Output Variation vs Temperature	$P_{IN} = -30$ to $+6$ dBm	± 1 dB
Deviation from CW Response	WiMAX OFDM Burst; $P_{IN} = -34$ to $+4$ dBm	± 0.5 dB
ADC Resolution		
ADC Resolution	(no missing code)	12 bits
Differential Linearity Error	EN=0V, Voltage on $V_{OUT}=0V$ to 1.8V, $V_{REF}=1.8V$	± 0.25
Measurement Resolution	1LSB= $V_{REF}/(4096 * 29mV/dB)$, $V_{REF}=1.8V$	15m dB

Table 1. Jumper Description for DC1638A

JUMPER	FUNCTION	RANGE/SETTING (DEFAULT)
JP1	VDD, ADC power supply voltage	3.3V
JP2	VREF, ADC reference input voltage	VREG=1.8V
JP3	OVDD, ADC output driver supply voltage	3.3V

DC590B QUICK START PROCEDURE

The DC590B is a USB controller board that allows PC to communicate through serial data interface. The Quick start guide for DC590B can be found here: <http://cds.linear.com/docs/Reference%20Design/dc590B.pdf>. Download and install the QuickEval software supplied for DC590B here: http://www.linear.com/designtools/software/quick_eval.jsp. Connect DC590B to the host PC with the USB A/B cable.

1. Connect the DC1638A to the DC590B USB serial controller board using the supplied 14-conductor ribbon cable.
2. Set **VCCIO on DC590B to 3.3V** on the USB controller board.
3. Set the JP4, the "EN", which will enable the EEPROM for DC590B to automatically recognize the DC1638A board with LTC5587 when connected.
4. Set JP5 to ON, for both ISO and SW, they provide the VCCIO voltage to DC1638.
5. JP1, and JP2 are not used. Leave open.

DC1638A QUICK START PROCEDURE

Demonstration circuit 1638A is easy to set up to evaluate the performance of the LTC5587. Refer to [Figure 2](#) for measurement equipment setup and follow the procedure below:

1. Connect DC power negative (-) supply to GND test point.
2. Connect DC power positive(+) supply to VCC and EN.
3. Set JP1(VDD) to 3.3V. This will power the LTC5587 Digital supply using the on board 3.3V regulator. The on board 3.3V regulator receives power from the DC590B board.
4. Set JP2(VREF) to VREG. This will supply the VREF using the on board 1.8V regulator. The on board 1.8V regulator receives power from the VCC supply.
5. Set JP3(OVDD) to 3.3V. This will power up the ADC output digital driver using the on board 3.3V regulator, which gets the power from DC590B.
6. Connect the signal generator's output to J1(RFIN), using the SMA connector. A 3dB attenuator pad may be used to improve broadband match, which will shift the detected power range up by 3dB.
7. The LTC5587 software control panel automatically opens when the DC1638A demo board is connected to the DC590B board. Using the Quick Eval software, set the VREF voltage to 1.8V.
8. Click on Collect to start reading the ADC.

NOTES:

1. The voltage on the EN test point must never exceed $V_{CC} + 0.3V$.

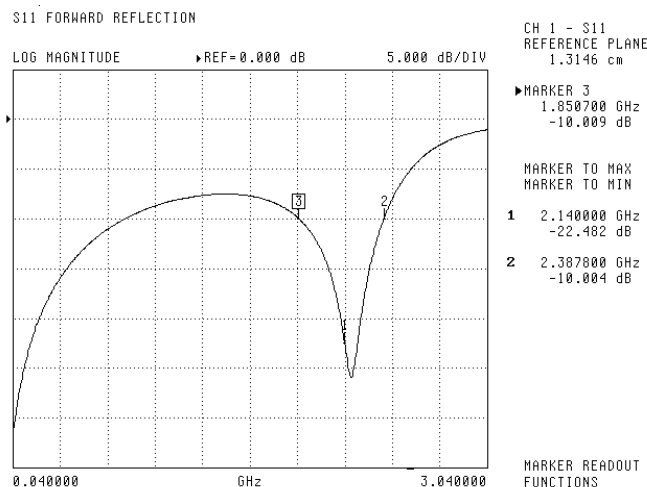

Figure 1. Standard Demo Board Return Loss

2. For digitally modulated signals, an oscilloscope can be used to observe the AC components of the output.
3. If no DC power supply is available, DC1638A can also be power up using the on board 3.3V regulator. Connect the 3.3V test point to VCC and EN.
4. Pin 6, C_{SQ} is the Optional Low Frequency Range Extension Capacitor. Use this pin for frequencies below 250MHz. Connect 0.01uF from Pin 8 to ground for 10MHz operation.
5. The software can display either ADC count, or the calculated voltage based on the ADC VREF input. Go to tools=>options to select.
6. The vertical axis can be toggled between Auto and Full by clicking on it at the upper left corner of the control panel.
7. Do not exceed +15dBm, the absolute maximum average RF input power.
8. V_{out} is the analog input voltage to the ADC. VREF defines the full-scale output range of ADC, 0V to VREF.

9. The Software allows datalog of output data, and saves the file as .adc format, which Microsoft Excel® can be used to open. Equivalent output voltage can be calculated from the ADC code based on the V_{REF} as follows.

$$V_{out} = \left(\frac{ADC\ Code * V_{ref}}{4096} \right)$$

Where $V_{REF}=1.8V$ for the standard demo board.

10. Linearity Error at any input power level can be calculated from the V_{out} , given the best fit slope and Log intercept, as follows:

$$Linearity\ Error = \left(\frac{V_{out}}{slope} \right) + Log\ Intercept + Pin$$

Best fit slope is taken for P_{in} from -20dBm to 0dBm.

11. Averaging Function can be turned on by clicking on the upper left hand corner on the front control panel, Figure 3.

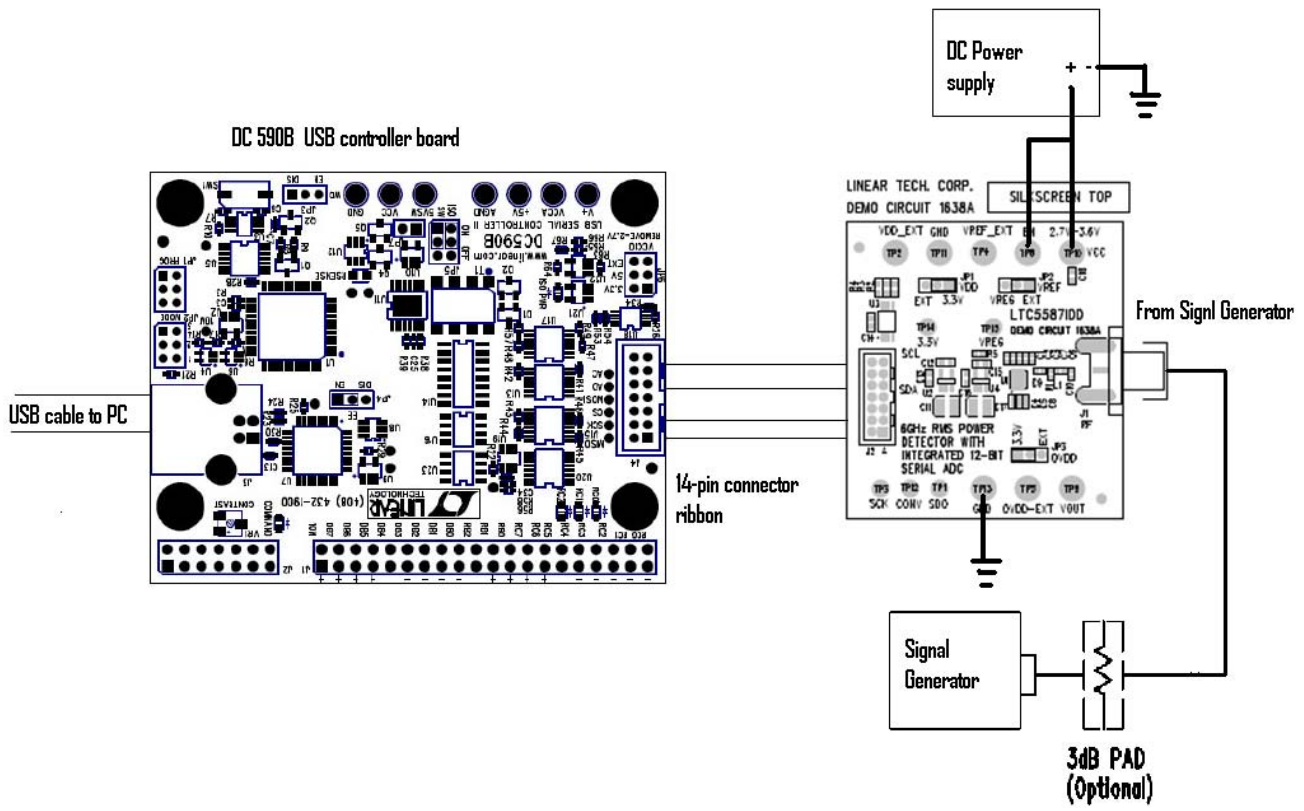

Figure 2. Proper test setup to connect DC1638A demo board to DC590A

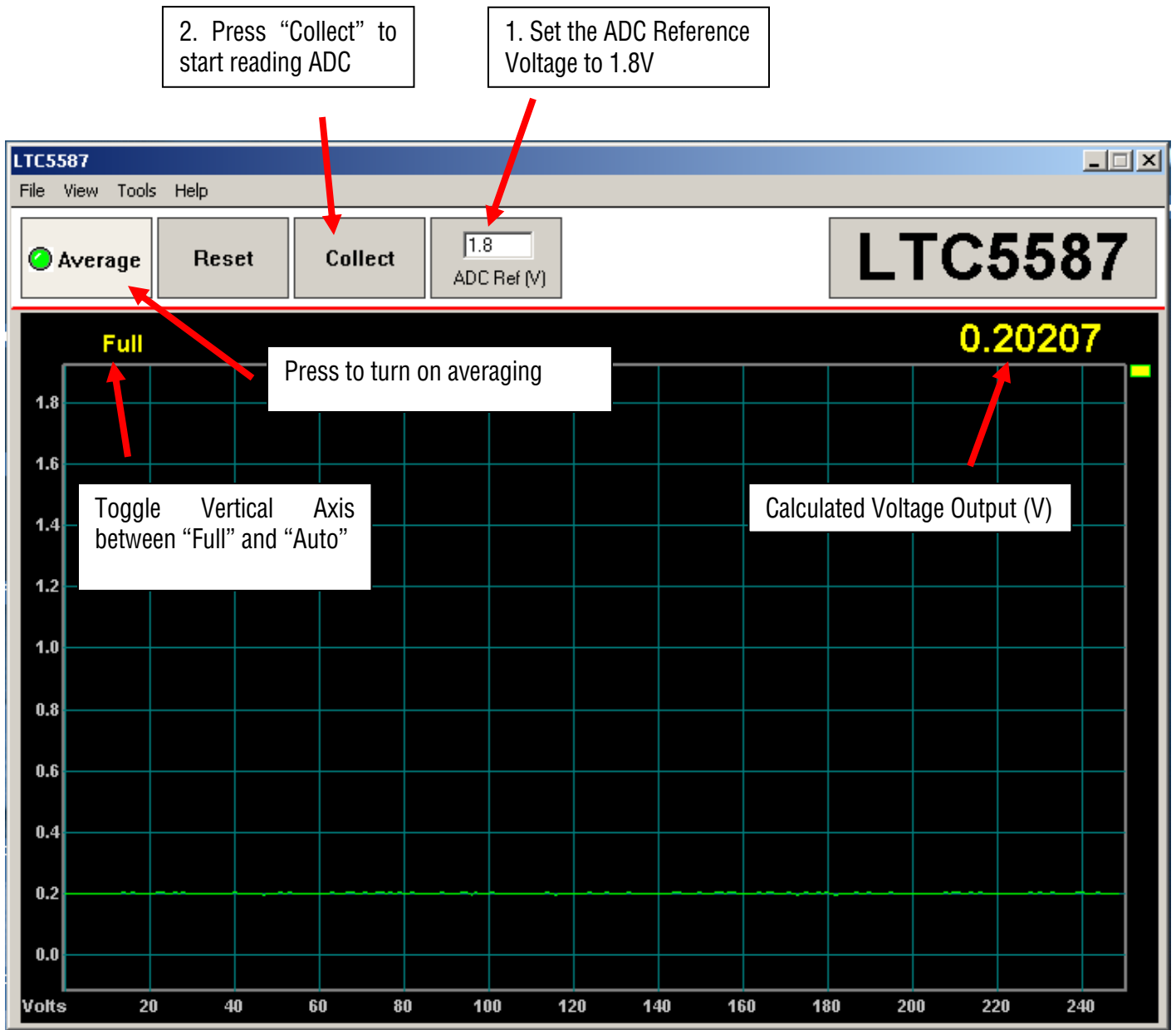
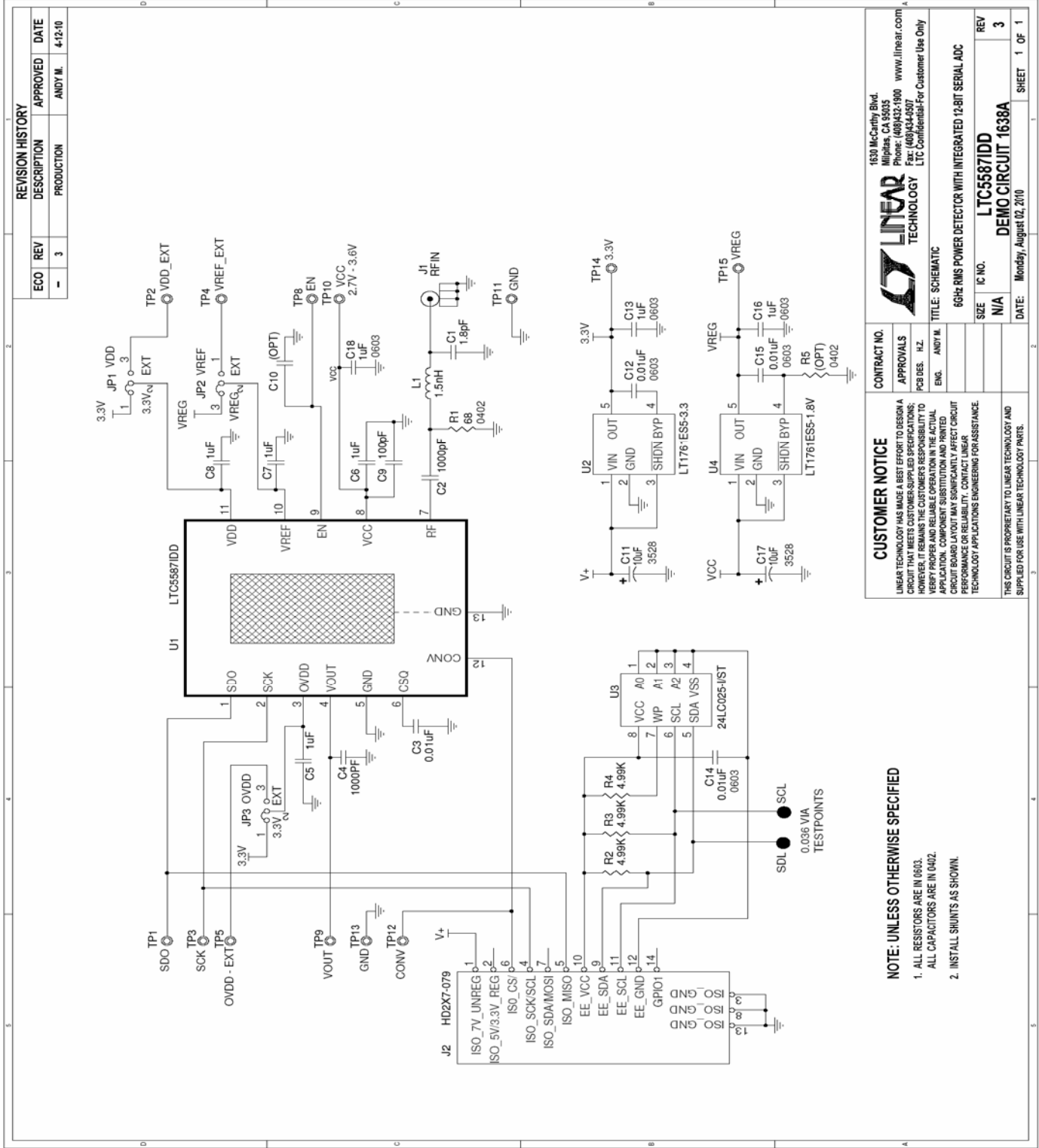

Figure 3. Front Control Panel for LTC5587. With no RF input signal.

Table 2. RF Input Modifications for various Frequency Ranges.

FREQUENCY RANGE	RF _{IN} MATCH	
	L1	C1
0.04 to 1.8GHz	3.3nH	1.8pF
1.75 to 2.2GHz	1.5nH	1.8pF
2.4 to 2.9GHz	0	1.5pF
2.8 to 3.8GHz	0	0.7pF
4.5 to 6.0GHz	0	0



REVISION HISTORY				
ECO	REV	DESCRIPTION	APPROVED	DATE
-	3	PRODUCTION	ANDY M.	4-12-10

CUSTOMER NOTICE

LINEAR TECHNOLOGY HAS MADE A BEST EFFORT TO DESIGN A CIRCUIT THAT MEETS CUSTOMER-SUPPLIED SPECIFICATIONS; HOWEVER, IT REMAINS THE CUSTOMER'S RESPONSIBILITY TO VERIFY PROPER AND RELIABLE OPERATION IN THE ACTUAL APPLICATION. COMPONENT SUBSTITUTION AND PRINTED CIRCUIT BOARD LAYOUT MAY SIGNIFICANTLY AFFECT CIRCUIT PERFORMANCE OR RELIABILITY. CONTACT LINEAR TECHNOLOGY APPLICATIONS ENGINEERING FOR ASSISTANCE.

THIS CIRCUIT IS PROPRIETARY TO LINEAR TECHNOLOGY AND SUPPLIED FOR USE WITH LINEAR TECHNOLOGY PARTS.

CONTRACT NO.

APPROVALS

PCB DES. H.Z.

ENG. ANDY M.

TITLE: SCHEMATIC

66Hz RMS POWER DETECTOR WITH INTEGRATED 12-BIT SERIAL ADC

SIZE: N/A

IC NO.: **LTC5587IDD**

DATE: Monday, August 02, 2010

SHEET 1 OF 1

NOTE: UNLESS OTHERWISE SPECIFIED

- ALL RESISTORS ARE IN 0603.
- ALL CAPACITORS ARE IN 0402.
- INSTALL SHUNTS AS SHOWN.

1630 McCarthy Blvd.
Milpitas, CA 95035
Phone: (408)432-1900 www.linear.com
Fax: (408)434-0507
LTC Confidential-For Customer Use Only

Компания «Океан Электроники» предлагает заключение долгосрочных отношений при поставках импортных электронных компонентов на взаимовыгодных условиях!

Наши преимущества:

- Поставка оригинальных импортных электронных компонентов напрямую с производств Америки, Европы и Азии, а так же с крупнейших складов мира;
- Широкая линейка поставок активных и пассивных импортных электронных компонентов (более 30 млн. наименований);
- Поставка сложных, дефицитных, либо снятых с производства позиций;
- Оперативные сроки поставки под заказ (от 5 рабочих дней);
- Экспресс доставка в любую точку России;
- Помощь Конструкторского Отдела и консультации квалифицированных инженеров;
- Техническая поддержка проекта, помощь в подборе аналогов, поставка прототипов;
- Поставка электронных компонентов под контролем ВП;
- Система менеджмента качества сертифицирована по Международному стандарту ISO 9001;
- При необходимости вся продукция военного и аэрокосмического назначения проходит испытания и сертификацию в лаборатории (по согласованию с заказчиком);
- Поставка специализированных компонентов военного и аэрокосмического уровня качества (Xilinx, Altera, Analog Devices, Intersil, Interpoint, Microsemi, Actel, Aeroflex, Peregrine, VPT, Syfer, Eurofarad, Texas Instruments, MS Kennedy, Miteq, Cobham, E2V, MA-COM, Hittite, Mini-Circuits, General Dynamics и др.);

Компания «Океан Электроники» является официальным дистрибьютором и эксклюзивным представителем в России одного из крупнейших производителей разъемов военного и аэрокосмического назначения «JONHON», а так же официальным дистрибьютором и эксклюзивным представителем в России производителя высокотехнологичных и надежных решений для передачи СВЧ сигналов «FORSTAR».



JONHON

«JONHON» (основан в 1970 г.)

Разъемы специального, военного и аэрокосмического назначения:

(Применяются в военной, авиационной, аэрокосмической, морской, железнодорожной, горно- и нефтедобывающей отраслях промышленности)

«FORSTAR» (основан в 1998 г.)

ВЧ соединители, коаксиальные кабели, кабельные сборки и микроволновые компоненты:

(Применяются в телекоммуникациях гражданского и специального назначения, в средствах связи, РЛС, а так же военной, авиационной и аэрокосмической отраслях промышленности).



Телефон: 8 (812) 309-75-97 (многоканальный)

Факс: 8 (812) 320-03-32

Электронная почта: ocean@oceanchips.ru

Web: <http://oceanchips.ru/>

Адрес: 198099, г. Санкт-Петербург, ул. Калинина, д. 2, корп. 4, лит. А