



ON Semiconductor®

<http://onsemi.com>

LC87F7932B

CMOS IC
32K-byte FROM and 2048-byte RAM integrated
8-bit 1-chip Microcontroller

Overview

The LC87F7932B is an 8-bit microcontroller that, centered around a CPU running at a minimum bus cycle time of 250ns, integrates on a single chip a number of hardware features such as 32K-byte flash ROM (onboard programmable), 2048-byte RAM, an on-chip debugger, an LCD controller/driver, two sophisticated 16-bit timers/counters (may be divided into 8-bit timers), two 16-bit timers/counters (may be divided into 8-bit timers/counters or 8-bit PWMs), four 8-bit timers with a prescaler, a real time clock function (RTC), a base timer serving as a time-of-day clock, a synchronous SIO interface with automatic transfer function, an asynchronous/synchronous SIO interface, a UART interface (full duplex), a 7-channel AD converter with a 12-/8-bit resolution selector, a high-speed clock counter, a system clock frequency divider, an internal reset circuit, and a 21-source 10-vector interrupt function.

Features

■Flash ROM

- Capable of on-board programming with a wide supply voltage range of 3.0V to 5.5V
- 128-byte block erase
- 32768×8 bits

■RAM

- 2048×9 bits

■Minimum Bus Cycle Time

- 250ns (4MHz) $V_{DD}=2.4V$ to 3.6V

Note: The bus cycle time here refers to the ROM read speed.

■Minimum Instruction Cycle Time (tCYC)

- 750ns (4MHz) $V_{DD}=2.4V$ to 3.6V

* This product is licensed from Silicon Storage Technology, Inc. (USA).

■ Operating Temperature Range

- -40°C to +85°C

■ Ports

- Normal withstand voltage I/O ports
 - Ports whose input/output can be programmed in 1-bit units: 21 (P0n, P1n, P30, P70 to P73)
 - Multiplexed functions
 - Input ports (for debugger): 3 (DBGP0 (P05) to DBGP2 (P07))
 - LCD ports (segment output): 8 (P1n)
- LCD ports/general purpose I/O ports
 - Segment output: 32 (S00 to S31)
 - Common output: 4 (COM0 to COM3)
 - Bias power supply for LCD driving: 5 (V1 to V3, CUP1, CUP2)
 - Multiplexed functions
 - Input/output ports: 36 (LPAn, LPBn, LPCn, LPL0 to LPL3, P1n)
- Oscillator pins: 4 (CF1, CF2, XT1, XT2)
- Reset pin: 1 ($\overline{\text{RES}}$)
- Power supply: 5 (VSS1, VSS2, VDD1, VDD2, V2)

■ LCD Controller

- (1) Seven display modes are available
- (2) Duty: 1/3 duty, 1/4 duty
- (3) Bias: 1/2 bias, 1/3 bias
- (4) Segment/common output can be switched to general purpose I/O ports.
- (5) LCD power range
 - 1) 1/3 bias
 - V1: 1.2V to 1.8V
 - V2: 2.4V to 3.6V
 - V3: 3.6V to 5.4V
 - An LCD panel that supports the $V2 (=V_{DD}) \times 1.5[V]$ must be used when 1/3 bias is selected.
 - If the supply voltage V_{DD} is 3.0V, for example, use an LCD panel that supports 4.5V.
 - 2) 1/2 bias
 - V1: 1.2V to 1.8V
 - V2: 2.4V to 3.6V
 - V3: 2.4V to 3.6V
 - (Connect V2 and V3 externally.)
 - An LCD panel that supports the $V2 (=V_{DD})[V]$ must be used when 1/2 bias is selected.
 - If the supply voltage V_{DD} is 3.0V, for example, use an LCD panel that supports 3.0V.

■ Timers

- Timer 0: 16 bit timer/counter with a capture register
 - Mode 0: 8-bit timer with an 8-bit programmable prescaler (with two 8-bit capture registers) \times 2 channels
 - Mode 1: 8 bit timer with an 8-bit programmable prescaler (with an 8-bit capture register) + 8-bit counter (with an 8-bit capture register)
 - Mode 2: 16 bit timer with an 8-bit programmable prescaler (with a 16-bit capture register)
 - Mode 3: 16 bit counter (with a 16 bit capture register)
- Timer 1: 16 bit timer/counter that supports PWM/toggle output
 - Mode 0: 8-bit timer with an 8-bit prescaler (with toggle output) + 8-bit timer/counter (with toggle output)
 - Mode 1: 8-bit PWM with an 8-bit prescaler \times 2 channels
 - Mode 2: 16 bit timer/counter with an 8-bit prescaler (with toggle output)
(Toggle outputs also from the low-order 8 bits)
 - Mode 3: 16 bit timer with an 8-bit prescaler (with toggle output)
(The low-order 8 bits can be used as a PWM.)
- Timer 4: 8-bit timer with a 6-bit prescaler
- Timer 5: 8-bit timer with a 6-bit prescaler
- Timer 6: 8-bit timer with a 6-bit prescaler (with toggle output)
- Timer 7: 8-bit timer with a 6-bit prescaler (with toggle output)
- Base Timer
 - (1) The clock can be selected from any of the following:
 - Subclock (32.768kHz crystal oscillator/low-speed RC oscillator), system clock, and timer 0 prescaler output.
 - (2) Interrupts can be generated at five specified time intervals.

■ High-speed Clock Counter

- (1) Capable of counting a clock with a maximum clock rate of 8MHz (at a main clock of 4MHz).
- (2) Real-time output

■ Serial Interface

- SIO0: 8-bit synchronous serial interface
 - (1) Synchronous 8-bit serial I/O (2- or 3-wire configuration, 4/3 to 512/3 tCYC transfer clock rate)
 - (2) Continuous data transfer (variable length data transfer in bit units from 1 to 256 bits, 4/3 to 512/3 tCYC transfer clock rate)
 - (3) Bi-phase modulation
Manchester/Bi-phase-Space data transfer
 - (4) LSB first/MSB first selectable
 - (5) SPI function: HOLD/X'tal HOLD mode release function upon receipt of a 1-byte (8-bit clock).
- SIO1: 8-bit asynchronous/synchronous serial interface
 - Mode 0: Synchronous 8-bit serial I/O (2- or 3-wire configuration, 2 to 512 tCYC transfer clock rate)
 - Mode 1: Asynchronous serial I/O (half duplex, 8 data bits, 1 stop bit, 8 to 2048 tCYC baudrate)
 - Mode 2: Bus mode 1 (start bit, 8 data bits, 2 to 512 tCYC transfer clock rate)
 - Mode 3: Bus mode 2 (start detection, 8 data bits, stop detection)

■ UART

- Full duplex
- Data length: 7/8/9 bits selectable
- 1 stop bit (2 bits in continuous data transmission)
- Built-in baudrate generator
- Operating mode: Programmable transfer mode, fixed-rate transfer mode
- Transfer data conversion: Normal (NRZ), Manchester encoding

■ AD Converter: 12 bits/8 bits × 7 channels

- 12-/8-bit AD converter resolution selectable

■ Remote Control Receiver Circuit (multiplexed with the P73/INT3/T0IN pin)

- Noise rejection function (Noise filter time constant selectable from 1/32/128 tCYC)

■ Watchdog Timer

- Generation of interrupt or system reset selectable
- Two types of watchdog timer
 - (1) Watchdog timer using an external RC circuit
 - (2) Watchdog timer using the microcontroller's base timer
- Detection intervals (1/2/4/8 seconds) can be selected for the watchdog timer that uses the base timer by configuring options.

■ Buzzer Output

- Generates buzzer output from P17 using the base timer.

■ Real Time Clock (RTC)

- (1) Uses the base timer to count the calendar years, months, days, hours, minutes, and seconds.
- (2) Calendar counts up to December 31, 2799 and calculates leap years automatically
- (3) The RTC uses the Gregorian calendar, which maintains GMT (Greenwich Mean Time).

■ Internal Reset Function

- Power-on-reset (POR) function
 - (1) The POR causes a system reset only when power is turned on.

■Interrupts:

- 21 sources, 10 vectors
- (1) Provides three levels (low (L), high (H), and highest (X)) of multiplex interrupt control. Any interrupt request of the level equal to or lower than the current interrupt is not accepted.
- (2) When interrupt requests to two or more vector addresses occur at the same time, the interrupt of the highest level takes precedence over the other interrupts. For interrupts of the same level, the interrupt into the lowest vector address takes precedence.

No.	Vector Address	Level	Interrupt Source
1	00003H	X or L	INT0
2	0000BH	X or L	INT1
3	00013H	H or L	INT2/T0L
4	0001BH	H or L	INT3/base timer/RTC
5	00023H	H or L	T0H
6	0002BH	H or L	T1L/T1H
7	00033H	H or L	SIO0/UART1-receive
8	0003BH	H or L	SIO1/UART-send
9	00043H	H or L	ADC/T6/T7/SPI
10	0004BH	H or L	Port 0/T4/T5

- Priority level: X > H > L
- For equal priority levels, the interrupt with the lowest vector address is given priority.

■Subroutine Stack Levels:

- Up to 1024 levels max. (Stack is allocated in RAM.)

■High-speed Multiplication/Division Instructions

- 16 bits × 8 bits (5 tCYC execution time)
- 24 bits × 16 bits (12 tCYC execution time)
- 16 bits ÷ 8 bits (8 tCYC execution time)
- 24 bits ÷ 16 bits (12 tCYC execution time)

■Oscillator Circuits

- On-chip high-speed RC oscillator: For system clock (500kHz typ)
- On-chip low-speed RC oscillator: For system clock (50kHz typ)
- CF oscillator: For system clock, Rf built in, Rd external
- Crystal oscillator: For low-speed system clock, Rf built in
- On-chip variable modulation frequency RC oscillator (VMRC): For system clock
 - (1) Adjustable in ±4% (typ) step from a selected center frequency
 - (2) Can measure the frequency of the source oscillator clock using an input signal from the XT1 pin as a reference.

■System Clock Divider

- Low consumption current operation possible
- The minimum instruction cycle can be selected from among 750ns, 1.5µs, 3.0µs, 6.0µs, 12µs, 24µs, 48µs, 96µs, and 192µs (at a main clock rate of 4MHz).

■System Clock Output

- The system clock can be output from the P04 pin.

LC87F7932B

■ Standby Function

- **HALT mode:** HALT mode is used to reduce power consumption.
Halts instruction execution while allowing the peripheral circuits to continue operation.
(Some serial transfer functions are suspended.)
 - (1) Oscillators do not stop automatically.
 - (2) Released by a system reset or occurrence of an interrupt
- **HOLD mode:** HOLD mode is used to reduce power consumption.
Suspends instruction execution and operation of the peripheral circuits.
 - (1) CF oscillator, RC oscillators, crystal oscillator, and VMRC oscillator stop automatically.
 - (2) There are five ways of releasing HOLD mode.
 - 1) Low level input to the reset pin
 - 2) Watchdog timer interrupt
 - 3) Specified level input to at least one of INT0, INT1, and INT2 pins
 - 4) Port 0 interrupt
 - 5) SPI interrupt by receiving 1-byte (8-bit clock)
- **X'tal HOLD mode:** X'tal HOLD mode is used to reduce power consumption.
Suspends instruction execution and the operation of the peripheral circuits except the base timer.
 - (1) CF oscillator, RC oscillators, and VMRC oscillator stop automatically.
 - (2) The state of the crystal oscillator when X'tal HOLD mode is entered is retained.
 - (3) There are seven ways of releasing X'tal HOLD mode.
 - 1) Low level input to the reset pin
 - 2) Watchdog timer interrupt
 - 3) Specified level input to at least one of INT0, INT1, and INT2 pins
 - 4) Port 0 interrupt
 - 5) Base-timer interrupt
 - 6) RTC interrupt
 - 7) SPI interrupt by receiving 1-byte (8-bit clock)

■ On-chip Debugger

- Supports software debugging with the IC mounted on the target board.

■ Package Form

- QIP64E (14×14) (Lead-and-halogen-free product)
- TQFP64J (7×7) (Lead-and-halogen-free product)
- SQFP64 (10×10) (Lead-and-halogen-free product)

■ Development Tools

- On-chip debugger: TCB87 TypeB+LC87F7932B

■ Flash ROM Programming Boards

Package	Programming Boards
QIP64E (14×14)	W87F70256Q
TQFP64J (7×7)	W87F70256TQ7
SQFP64 (10×10)	W87F79256SQ

LC87F7932B

■Flash ROM Programmer

Maker		Model	Supported Version	Device
Flash Support Group, Inc. (Formerly Ando Electric Co., Ltd.)	Single	AF9708/AF9709/AF9709B	Rev 03.04 or later	LC87F2832A
	Ganged	AF9723 (Main unit)	Rev 0x.xx or later	
		AF9833 (Unit)	Rev 0x.xx or later	
Our company	Single/ganged	SKK/SKK Type B (SANYO FWS)	Application Version 1.05A or later	LC87F7932B
	Onboard	SKK/SKK Type B	Chip Data Version	
	Single/ganged	(SANYO FWS)	2.25 or later	

For information about AF-Series:

Flash Support Group, Inc.

TEL: +81-53-459-1050

E-mail: sales@j-fsg.co.jp

LC87F7932B

Package Dimensions

unit : mm (typ)
3159A

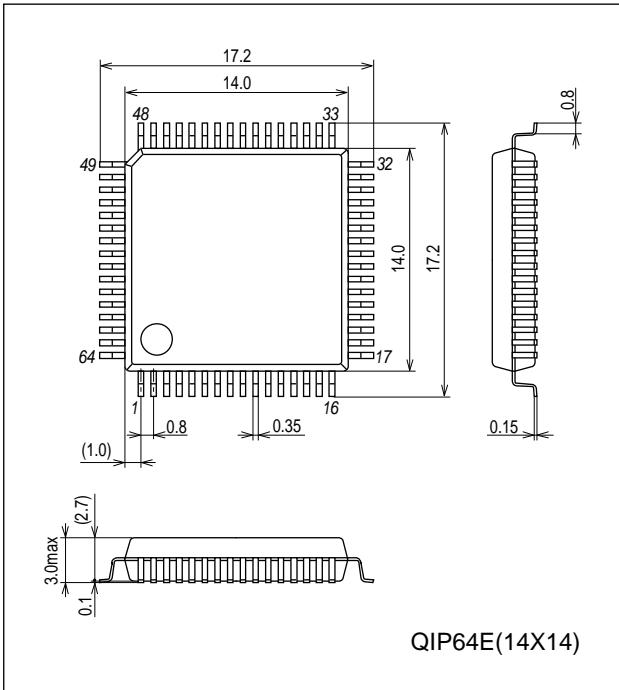

Package Dimensions

unit : mm (typ)
3289

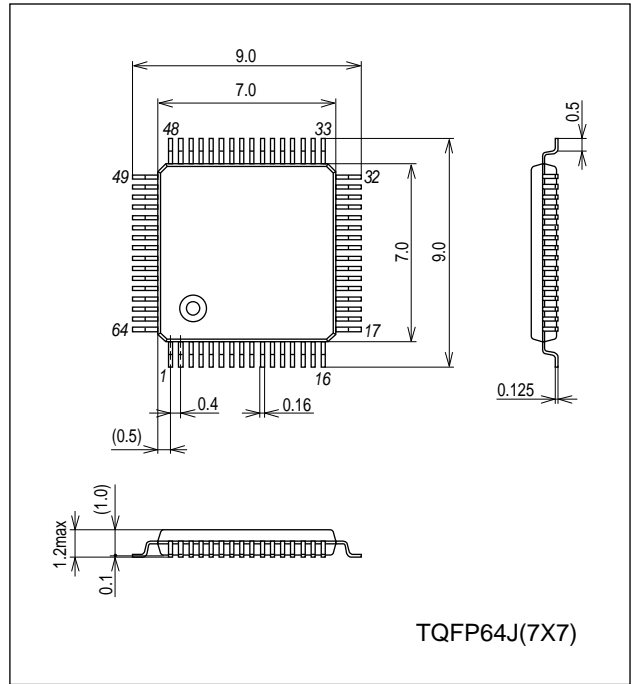

Package Dimensions

unit : mm (typ)
3190A

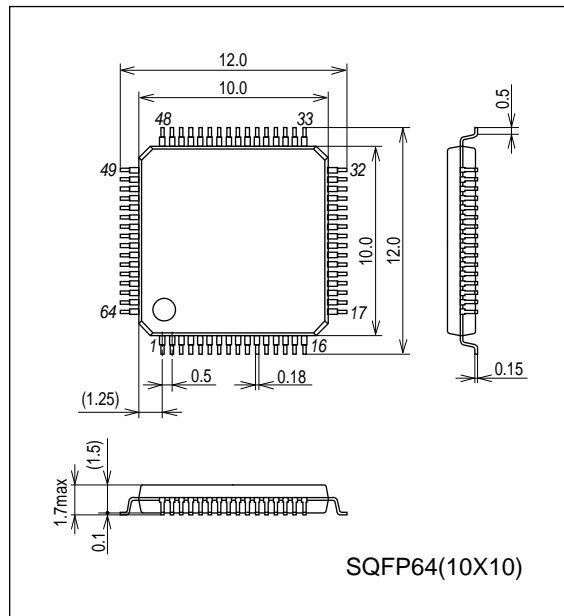

LC87F7932B

Pin Assignment

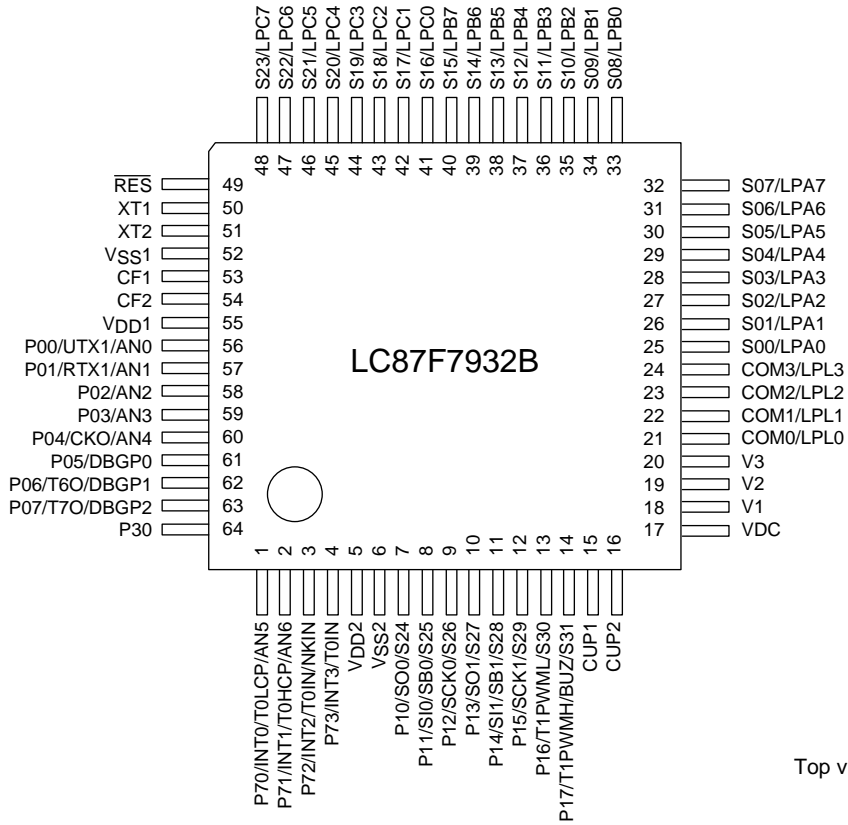

- QIP64E (14×14) “Lead-and-halogen-free product”
- TQFP64J (7×7) “Lead-and-halogen-free product”
- SQFP64 (10×10) “Lead-and-halogen-free product”

LC87F7932B

PIN No.	NAME
1	P70/INT0/T0LCP/AN5
2	P71/INT1/T0HCP/AN6
3	P72/INT2/T0IN/NKIN
4	P73/INT3/T0IN
5	V _{DD2}
6	V _{SS2}
7	P10/SO0/S24
8	P11/SI0/SB0/S25
9	P12/SCK0/S26
10	P13/SO1/S27
11	P14/SI1/SB1/S28
12	P15/SCK1/S29
13	P16/T1PWML/S30
14	P17/T1PWMLH/BUZ/S31
15	CUP1
16	CUP2
17	VDC
18	V1
19	V2
20	V3
21	COM0/LPL0
22	COM1/LPL1
23	COM2/LPL2
24	COM3/LPL3
25	S00/LPA0
26	S01/LPA1
27	S02/LPA2
28	S03/LPA3
29	S04/LPA4
30	S05/LPA5
31	S06/LPA6
32	S07/LPA7

PIN NO.	NAME
33	S08/LPB0
34	S09/LPB1
35	S10/LPB2
36	S11/LPB3
37	S12/LPB4
38	S13/LPB5
39	S14/LPB6
40	S15/LPB7
41	S16/LPC0
42	S17/LPC1
43	S18/LPC2
44	S19/LPC3
45	S20/LPC4
46	S21/LPC5
47	S22/LPC6
48	S23/LPC7
49	$\overline{\text{RES}}$
50	XT1
51	XT2
52	V _{SS1}
53	CF1
54	CF2
55	V _{DD1}
56	P00/UTX1/AN0
57	P01/RTX1/AN1
58	P02/AN2
59	P03/AN3
60	P04/CKO/AN4
61	P05/DBGP0
62	P06/T6O/DBGP1
63	P07/T7O/DBGP2
64	P30

System Block Diagram

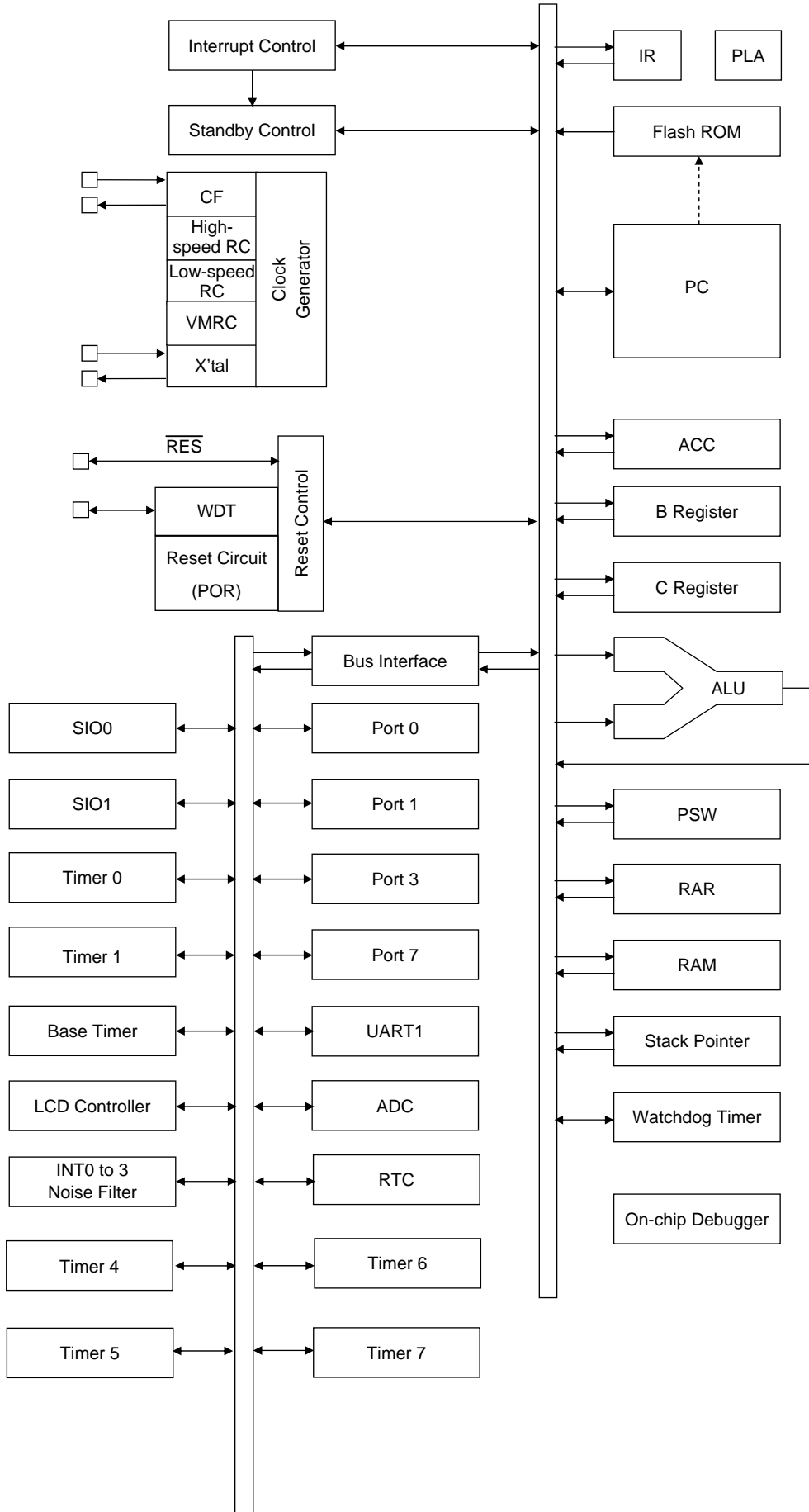

LC87F7932B

Pin Description

Pin Name	I/O	Description	Option																														
V _{SS1} , V _{SS2}	-	• Power supply (-)	No																														
V _{DD1} , V _{DD2} , V ₂	-	• Power supply (+)	No																														
V _{DC}	-	• Internal power supply	No																														
CUP1, CUP2	-	• Capacitor connecting pins for step-up/step-down circuits	No																														
Port 0 P00 to P07	I/O	<ul style="list-style-type: none"> • 8-bit I/O port • I/O can be specified in 1-bit units. • Pull-up resistors can be turned on and off in 1-bit units. • HOLD release input • Port 0 interrupt input • Multiplexed functions <ul style="list-style-type: none"> P00: UART1 transmit data output P01: UART1 receive data input P04: System clock output P05: DBGPO (LC87F7932B) P06: Timer 6 toggle output/DBGP1 (LC87F7932B) P07: Timer 7 toggle output/DBGP2 (LC87F7932B) AD converter input ports: AN0 (P00) to AN4 (P04) 	Yes																														
Port 1 P10/S24 to P17/S31	I/O	<ul style="list-style-type: none"> • 8-bit I/O port • I/O can be specified in 1-bit units. • Pull-up resistors can be turned on and off in 1-bit units. • Multiplexed functions <ul style="list-style-type: none"> P10: SIO0 data output P11: SIO0 data input or bus I/O P12: SIO0 clock I/O P13: SIO1 data output P14: SIO1 data input or bus I/O P15: SIO1 clock I/O P16: Timer 1 PWML output P17: Timer 1 PWMH output/buzzer output Segment output for LCD: S24 (P10) to S31 (S17) 	Yes																														
Port 3 P30	I/O	<ul style="list-style-type: none"> • 1-bit I/O port • I/O can be specified in 1-bit units. • Pull-up resistors can be turned on and off in 1-bit units. 	Yes																														
Port 7 P70 to P73	I/O	<ul style="list-style-type: none"> • 4-bit I/O port • I/O can be specified in 1-bit units. • Pull-up resistors can be turned on and off in 1-bit units. • Multiplexed functions <ul style="list-style-type: none"> P70: INT0 input/HOLD release input/timer 0L capture input/output for watchdog timer P71: INT1 input/HOLD release input/timer 0H capture input P72: INT2 input/HOLD release input/timer 0 event input/timer 0L capture input/high-speed clock counter input P73: INT3 input (with noise filter)/timer 0 event input/timer 0H capture input AD converter input ports: AN5 (P70), AN6 (P71) Interrupt acknowledge type <table border="1" style="margin-left: 20px; width: 100%; border-collapse: collapse;"> <thead> <tr> <th></th> <th>Rising</th> <th>Falling</th> <th>Rising and falling</th> <th>H level</th> <th>L level</th> </tr> </thead> <tbody> <tr> <td>INT0</td> <td>Enable</td> <td>Enable</td> <td>Disable</td> <td>Enable</td> <td>Enable</td> </tr> <tr> <td>INT1</td> <td>Enable</td> <td>Enable</td> <td>Disable</td> <td>Enable</td> <td>Enable</td> </tr> <tr> <td>INT2</td> <td>Enable</td> <td>Enable</td> <td>Enable</td> <td>Disable</td> <td>Disable</td> </tr> <tr> <td>INT3</td> <td>Enable</td> <td>Enable</td> <td>Enable</td> <td>Disable</td> <td>Disable</td> </tr> </tbody> </table> 		Rising	Falling	Rising and falling	H level	L level	INT0	Enable	Enable	Disable	Enable	Enable	INT1	Enable	Enable	Disable	Enable	Enable	INT2	Enable	Enable	Enable	Disable	Disable	INT3	Enable	Enable	Enable	Disable	Disable	No
	Rising	Falling	Rising and falling	H level	L level																												
INT0	Enable	Enable	Disable	Enable	Enable																												
INT1	Enable	Enable	Disable	Enable	Enable																												
INT2	Enable	Enable	Enable	Disable	Disable																												
INT3	Enable	Enable	Enable	Disable	Disable																												

Continued on next page.

LC87F7932B

Continued from preceding page.

Pin name	I/O	Description	Option
S00/LPA0 to S07/LPA7	I/O	<ul style="list-style-type: none"> Segment output for LCD Can be used as general purpose I/O ports (LPA) 	No
S08/LPB0 to S15/LPB7	I/O	<ul style="list-style-type: none"> Segment output for LCD Can be used as general purpose I/O ports (LPB) 	No
S16/LPC0 to S23/LPC7	I/O	<ul style="list-style-type: none"> Segment output for LCD Can be used as general purpose I/O ports (LPC) 	No
COM0/LPL0 to COM3/LPL3	I/O	<ul style="list-style-type: none"> Common output for LCD Can be used as general purpose I/O ports (LPL) 	No
V1 to V3	I/O	<ul style="list-style-type: none"> LCD drive bias power supply 	No
$\overline{\text{RES}}$	I	<ul style="list-style-type: none"> Reset pin 	No
XT1	I/O	<ul style="list-style-type: none"> 32.768kHz crystal resonator input pin General purpose input port Must be connected to V_{DD1} if not to be used. 	No
XT2	I/O	<ul style="list-style-type: none"> 32.768kHz crystal resonator output pin General purpose I/O port Must be set for oscillation and kept open if not to be used. 	No
CF1	I	<ul style="list-style-type: none"> Ceramic resonator input pin Must be connected to V_{DD1} if not to be used. 	No
CF2	O	<ul style="list-style-type: none"> Ceramic resonator output pin Must be kept open if not to be used. 	No

Port Output Types

The table below lists the types of port outputs and the presence/absence of a pull-up resistor.

Data can be read into any input port even if it is in output mode.

Port	Options Selected in Units of	Option Type	Output Type	Pull-up Resistor
P00 to P07	1 bit	1	CMOS	Programmable
		2	N-channel open drain	Programmable
P10 to P17	1 bit	1	CMOS	Programmable
		2	N-channel open drain	Programmable
P30	1 bit	1	CMOS	Programmable
		2	N-channel open drain	Programmable
P70	-	No	N-channel open drain	Programmable
P71 to P73	-	No	CMOS	Programmable
S00/LPA0 to S23/LPC7	-	No	CMOS	No
			P-channel open drain	
			N-channel open drain	
COM0/LPL0 to COM3/LPL3	-	No	CMOS	No
			P-channel open drain	
			N-channel open drain	
XT1	-	No	Input only	No
XT2	-	No	32.768kHz crystal resonator output	No
			N-channel open drain when selected as a general-purpose output port	

LC87F7932B

User Option Table

Option Name	Option to be Applied on	Mask Version *1	Flash-ROM Version	Option Selected in Units of	Option Selection
Port output type	P00 to P07		○	1 bit	CMOS N-channel open drain
	P10 to P17		○	1 bit	CMOS N-channel open drain
	P30		○	1 bit	CMOS N-channel open drain
Base timer watchdog timer	Watchdog timer detection period		○	-	1 second
					2 seconds
					4 seconds
					8 seconds
Program start address	-	*2	○	-	00000h 07E00h

*1: Mask option selection. No change possible after mask is completed.

*2: Program start address of the mask version is 00000h.

*Note 1: Connect the IC as shown below to minimize noise on the V_{DD1}.

Be sure to electrically short the V_{SS1} and V_{SS2}.

*Note 2: The power to retain the internal memory is supplied via the V2 pin. V_{DD1}, V_{DD2} and V2 are used as power supply for ports. If V_{DD1} and V_{DD2} are not backed up, the output does not go high even if a high level is applied to the port latch. Therefore, if V_{DD1} and V_{DD2} are not backed up, the high level output becomes unstable in HOLD mode, and the backup time becomes shorter because a through-current flows from V_{DD} to GND in the input buffer.

If V_{DD1} and V_{DD2} are not backed up, configure the program or set up the external circuit so that the output is held at a low level in HOLD mode to prevent an unnecessary through-current from flowing.

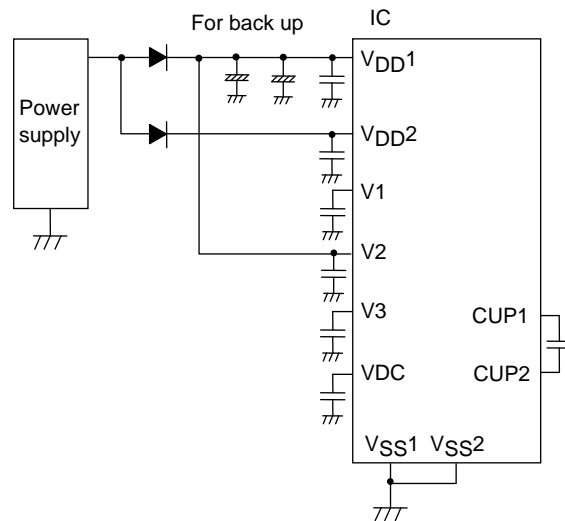

LC87F7932B

Circuit Example

(1)1/3 bias, 1/4 duty

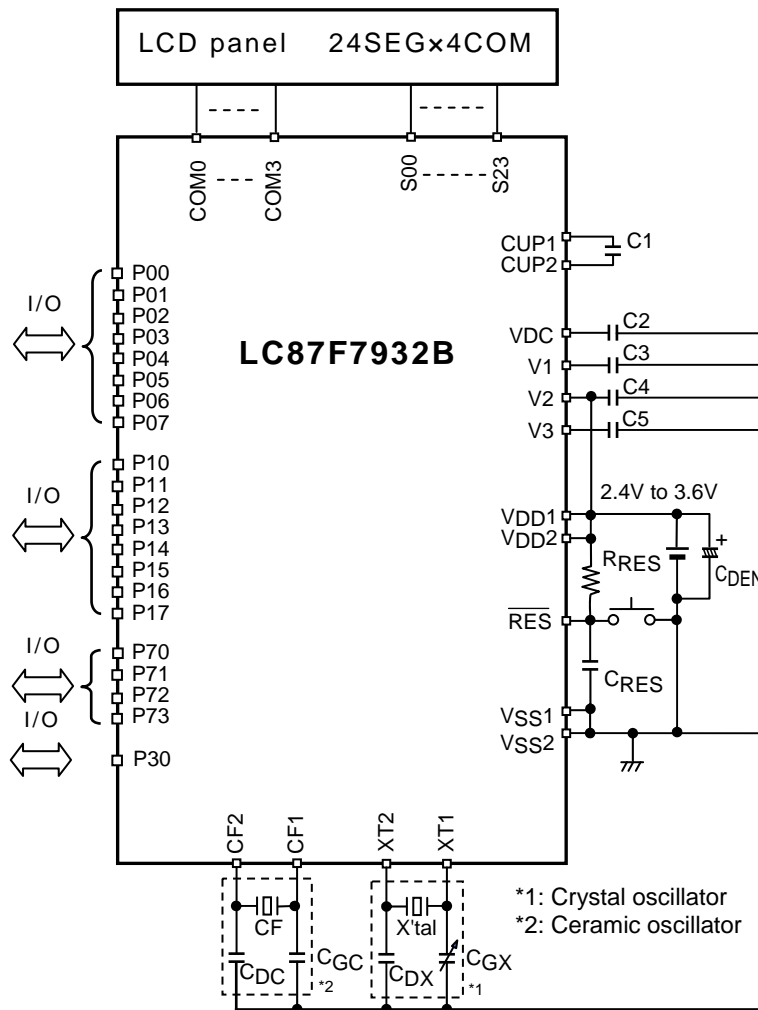

X'tal	Crystal resonator	Refer to Page 26 (Characteristics of a sample clock oscillator circuit)
CGX	Trimmer capacitor	
CDX	Capacitor for crystal oscillator	
CF	Ceramic resonator	Refer to Page 26 (Characteristics of a sample clock oscillator circuit)
CGC	Capacitor for ceramic oscillator	
CD _C	Capacitor for ceramic oscillator	
C1 to C5	Capacitors	0.1μF (recommended)
CD _{EN}	Electrolytic capacitor	For back up
C _{RES}	Capacitor for $\overline{\text{RES}}$	Refer to User's manual "Reset Function"
R _{RES}	Resistor for $\overline{\text{RES}}$	

LC87F7932B

(2)1/2 bias, 1/3 duty

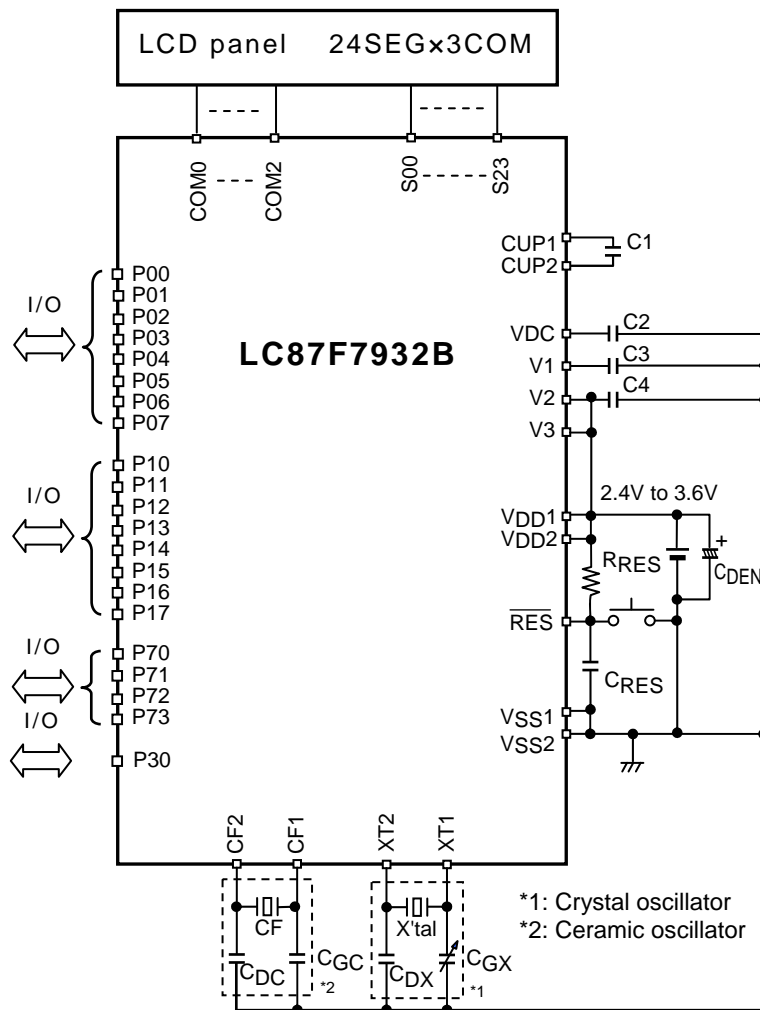

X'tal	Crystal resonator	Refer to Page 26 (Characteristics of a sample clock oscillator circuit)
CGX	Trimmer capacitor	
CDX	Capacitor for crystal oscillator	
CF	Ceramic resonator	Refer to Page 26 (Characteristics of a sample clock oscillator circuit)
CGC	Capacitor for ceramic oscillator	
CD _C	Capacitor for ceramic oscillator	
C1 to C4	Capacitors	0.1μF (recommended)
CDEN	Electrolytic capacitor	For back up
CRES	Capacitor for $\overline{\text{RES}}$	Refer to User's manual "Reset Function"
RRES	Resistor for $\overline{\text{RES}}$	

LC87F7932B

Absolute Maximum Ratings at Ta=25°C and VSS1=VSS2=0V

Parameter	Symbol	Pin/Remarks	Conditions	Specification				
				VDD[V]	min	typ	max	unit
Maximum supply voltage	VDD max	VDD1, VDD2, V2	VDD1=VDD2=V2		-0.3		+4.3	V
Supply voltage for LCD	VLCD	V1			-0.3		1/2VDD	
		V2			-0.3		VDD	
		V3			-0.3		2/3VDD	
Input voltage	VI	XT1, CF1, RES			-0.3		VDD+0.3	
Input/output voltage	VI/O(1)	Ports 0, 1, 3, 7 LPA, LPB, LPC LPL, XT2			-0.3		VDD+0.3	
High level output current	Peak output current	IOPH(1)	Ports 0, 1	• CMOS output selected • Current at each pin		-10		mA
		IOPH(2)	Port 3	• CMOS output selected		-20		
		IOPH(3)	LPA, LPB, LPC LPL	• CMOS output selected • Current at each pin		-4		
		IOPH(4)	P71 to P73	• Current at each pin		-5		
	Total output current	ΣIOAH(1)	Port 0	Total of all pins		-20		
		ΣIOAH(2)	Ports 3, 7	Total of all pins		-30		
		ΣIOAH(3)	Port 1	Total of all pins		-20		
		ΣIOAH(4)	Ports 1, 3, 7	Total of all pins		-45		
		ΣIOAH(5)	LPA, LPB, LPC, LPL	Total of all pins		-30		
Low level output current	Peak output current	IOPL(1)	Ports 0, 1	Current at each pin			20	
		IOPL(2)	Port 3	Current at each pin			30	
		IOPL(3)	Port 7	Current at each pin			10	
		IOPL(4)	LPA, LPB, LPC, LPL	Current at each pin			6	
	Total output current	ΣIOAL(1)	Port 0	Total of all pins				40
		ΣIOAL(2)	Ports 3, 7	Total of all pins				50
		ΣIOAL(3)	Port 1	Total of all pins				40
		ΣIOAL(4)	Ports 1, 3, 7	Total of all pins				65
		ΣIOAL(5)	LPA, LPB, LPC, LPL	Total of all pins				60
Allowable power dissipation	Pd max	QIP64E (14×14)	Ta = -40°C to +85°C				267	
		TQFP64J (7×7)					152	
		SQFP64 (10×10)					192	
Operating temperature range	Topr				-40		85	°C
Storage temperature range	Tstg				-55		125	

Stresses exceeding Maximum Ratings may damage the device. Maximum Ratings are stress ratings only. Functional operation above the Recommended Operating Conditions is not implied. Extended exposure to stresses above the Recommended Operating Conditions may affect device reliability.

LC87F7932B

Allowable Operating Conditions at Ta=-40°C to +85°C, V_{SS1}=V_{SS2}=0V

Parameter	Symbol	Pin/Remarks	Conditions	Specification					
				V _{DD} [V]	min	typ	max	unit	
Operating supply voltage (Note 2-1)	V _{DD} (1)	V _{DD1} =V _{DD2} =V2	0.75μs≤t _{CYC} ≤200μs Normal mode		2.4		3.6	V	
Memory sustaining supply voltage	V _H D	V _{DD1} =V _{DD2} =V2	RAM and register contents sustained in HOLD mode.		2.2		3.6		
High level input voltage	V _{IH} (1)	Ports 0, 3 LPA, LPB, LPC, LPL	Output disabled	2.4 to 3.6	0.3V _{DD} +0.7		V _{DD}		
	V _{IH} (2)	Port 1 P71 to 73 P70 port input / interrupt side	• Output disabled • When INT1V _{TSL} =0 (P71 only)	2.4 to 3.6	0.3V _{DD} +0.7		V _{DD}		
	V _{IH} (3)	P71 interrupt side	• Output disabled • When INT1V _{TSL} =1	2.4 to 3.6	0.85V _{DD}		V _{DD}		
	V _{IH} (4)	P70 watchdog timer side	Output disabled	2.4 to 3.6	0.9V _{DD}		V _{DD}		
	V _{IH} (5)	XT1, XT2, CF1, \overline{RES}		2.4 to 3.6	0.75V _{DD}		V _{DD}		
Low level input voltage	V _{IL} (1)	Ports 0, 3 LPA, LPB, LPC, LPL	Output disabled	2.4 to 3.6	V _{SS}		0.2V _{DD}		
	V _{IL} (2)	Port 1 P71 to 73 P70 port input / interrupt side	• Output disabled • When INT1V _{TSL} =0 (P71 only)	2.4 to 3.6	V _{SS}		0.2V _{DD}		
	V _{IL} (3)	P71 interrupt side	• Output disabled • When INT1V _{TSL} =1	2.4 to 3.6	V _{SS}		0.45V _{DD}		
	V _{IL} (4)	P70 watchdog timer side	Output disabled	2.4 to 3.6	V _{SS}		0.8V _{DD} -1.0		
	V _{IL} (5)	XT1, XT2, CF1, \overline{RES}		2.4 to 3.6	V _{SS}		0.25V _{DD}		
Instruction cycle time (Note 2-2)	t _{CYC}			2.4 to 3.6			200		μs
External system clock frequency	F _{EXCF} (1)	CF1	• CF2 pin open • System clock frequency division ratio = 1/1 • External system clock duty = 50±5%	2.4 to 3.6	0.1		4		MHz
			• CF2 pin open • System clock frequency division ratio = 1/2	2.4 to 3.6	0.2		8		
Oscillation frequency range (Note 2-3)	F _{mCF} (1)	CF1, CF2	• 4MHz ceramic oscillation • See Fig. 1.	2.4 to 3.6		4		MHz	
	F _{mRC} (1)		Internal high-speed RC oscillation	2.4 to 3.6	250	500	750		
	F _{sRC} (1)		Internal low-speed RC oscillation	2.4 to 3.6	25	50	75	kHz	
	F _{sX'tal}	XT1, XT2	• 32.768kHz crystal oscillation • See Fig. 2.	2.4 to 3.6		32.768			
VMRC oscillation usable range	OpVMRC(1)		When VMSL4M=0	3.0 to 3.6	8	10	12	MHz	
	OpVMRC(2)		When VMSL4M=1	2.4 to 3.6	3.5	4	4.5		
VMRC oscillation adjustment range	VmADJ(1)		Each step of VMRAJn (Wide range)	2.4 to 3.6	8	24	64	%	
	VmADJ(2)		Each step of VMFAJn (Small range)	2.4 to 3.6	1	4	8		

Note 2-1: V_{DD} must be held greater than or equal to 3.0V in the flash ROM onboard programming mode.

Note 2-2: Relationship between t_{CYC} and oscillation frequency is 3/F_{mCF} at a division ratio of 1/1 and 6/F_{mCF} at a division ratio of 1/2.

Note 2-3: See Tables 1 and 2 for the oscillation constants.

LC87F7932B

Electrical Characteristics at $T_a = -40^\circ\text{C}$ to $+85^\circ\text{C}$, $V_{SS1} = V_{SS2} = 0\text{V}$

Parameter	Symbol	Pin/Remarks	Conditions	Specification				
				$V_{DD}[\text{V}]$	min	typ	max	unit
High level input current	$I_{IH}(1)$	Ports 0, 1, 3, 7 LPA, LPB, LPC LPL	<ul style="list-style-type: none"> Output disabled Pull-up resistor off $V_{IN} = V_{DD}$ (Including output Tr's off leakage current) 	2.4 to 3.6			1	μA
	$I_{IH}(2)$	$\overline{\text{RES}}$	$V_{IN} = V_{DD}$	2.4 to 3.6			1	
	$I_{IH}(3)$	XT1, XT2	<ul style="list-style-type: none"> Input port specification $V_{IN} = V_{DD}$ 	2.4 to 3.6			1	
	$I_{IH}(4)$	CF1	$V_{IN} = V_{DD}$	2.4 to 3.6			15	
Low level input current	$I_{IL}(1)$	Ports 0, 1, 3, 7 LPA, LPB, LPC LPL	<ul style="list-style-type: none"> Output disabled Pull-up resistor off $V_{IN} = V_{SS}$ (Including output Tr's off leakage current) 	2.4 to 3.6	-1			μA
	$I_{IL}(2)$	$\overline{\text{RES}}$	$V_{IN} = V_{SS}$	2.4 to 3.6	-1			
	$I_{IL}(3)$	XT1, XT2	<ul style="list-style-type: none"> Input port specification $V_{IN} = V_{SS}$ 	2.4 to 3.6	-1			
	$I_{IL}(4)$	CF1	$V_{IN} = V_{SS}$	2.4 to 3.6	-15			
High level output voltage	$V_{OH}(1)$	CMOS output ports 0, 1	$I_{OH} = -0.4\text{mA}$	3.0 to 3.6	$V_{DD} - 0.4$			V
	$V_{OH}(2)$		$I_{OH} = -0.2\text{mA}$	2.4 to 3.6	$V_{DD} - 0.4$			
	$V_{OH}(3)$	CMOS output port 3	$I_{OH} = -1.6\text{mA}$	3.0 to 3.6	$V_{DD} - 0.4$			
	$V_{OH}(4)$		$I_{OH} = -1\text{mA}$	2.4 to 3.6	$V_{DD} - 0.4$			
	$V_{OH}(5)$	P71 to 73	$I_{OH} = -0.4\text{mA}$	3.0 to 3.6	$V_{DD} - 0.4$			
	$V_{OH}(6)$		$I_{OH} = -0.2\text{mA}$	2.4 to 3.6	$V_{DD} - 0.4$			
	$V_{OH}(7)$	LPA, LPB, LPC LPL	$I_{OH} = -0.1\text{mA}$	2.4 to 3.6	$V_{DD} - 0.4$			
Low level output voltage	$V_{OL}(1)$	Ports 0, 1	$I_{OL} = 1.6\text{mA}$	3.0 to 3.6			0.4	V
	$V_{OL}(2)$		$I_{OL} = 1\text{mA}$	2.4 to 3.6			0.4	
	$V_{OL}(3)$	Port 3	$I_{OL} = 5\text{mA}$	3.0 to 3.6			0.4	
	$V_{OL}(4)$		$I_{OL} = 2.5\text{mA}$	2.4 to 3.6			0.4	
	$V_{OL}(5)$	Port 7 XT2	$I_{OL} = 1.6\text{mA}$	3.0 to 3.6			0.4	
	$V_{OL}(6)$		$I_{OL} = 1\text{mA}$	2.4 to 3.6			0.4	
	$V_{OL}(7)$	LPA, LPB, LPC LPL	$I_{OL} = 0.1\text{mA}$	2.4 to 3.6			0.4	
LCD output voltage deviation	VODLS	S00 to S31	<ul style="list-style-type: none"> $I_O = 0\text{mA}$ V1, V2, V3 LCD level output See Fig. 8. 	2.4 to 3.6	0		± 0.2	V
	VODLC	COM0 to COM3	<ul style="list-style-type: none"> $I_O = 0\text{mA}$ V1, V2, V3 LCD level output See Fig. 8. 	2.4 to 3.6	0		± 0.2	
Pull-up resistance	$R_{pu}(1)$	Ports 0, 1, 3, 7	$V_{OH} = 0.9V_{DD}$	2.4 to 3.6	18	50	150	$\text{k}\Omega$
Hysteresis voltage	$V_{HYS}(1)$	Ports 1, 7 $\overline{\text{RES}}$		2.4 to 3.6		$0.1V_{DD}$		V
Pin capacitance	CP	All pins	<ul style="list-style-type: none"> For pins other than that under test: $V_{IN} = V_{SS}$ $f = 1\text{MHz}$ $T_a = 25^\circ\text{C}$ 	2.4 to 3.6		10		pF

LC87F7932B

Serial I/O Characteristics at $T_a = -40^{\circ}\text{C}$ to $+85^{\circ}\text{C}$, $V_{SS1} = V_{SS2} = 0\text{V}$

1. SIO0 Serial I/O Characteristics (Note 4-1-1)

Parameter		Symbol	Pin/Remarks	Conditions	$V_{DD}[\text{V}]$	Specification					
						min	typ	max	unit		
Serial clock	Input clock	Frequency	tSCK(1)	SCK0(P12)	See Fig. 6.	2.4 to 3.6	2			tCYC	
		Low level pulse width	tSCKL(1)				1				
		High level pulse width	tSCKH(1)				1				
			tSCKHA(1)	<ul style="list-style-type: none"> • Continuous data transmission/reception mode • See Fig. 6. • (Note 4-1-2) 	4						
	Output clock	Frequency	tSCK(2)		SCK0(P12)	<ul style="list-style-type: none"> • CMOS output selected • See Fig. 6. 	2.4 to 3.6	4/3			tSCK
		Low level pulse width	tSCKL(2)					1/2			
High level pulse width		tSCKH(2)	1/2								
		tSCKHA(2)	<ul style="list-style-type: none"> • Continuous data transmission/reception mode • CMOS output selected • See Fig. 6. 	tSCKH(2) +2tCYC		tSCKH(2) +(10/3) tCYC	tCYC				
Serial input	Data setup time	tsDI(1)		SB0(P11), SIO(P11)	<ul style="list-style-type: none"> • Must be specified with respect to the rising edge of SIOCLK. • See Fig. 6. 	2.4 to 3.6	0.03				
	Data hold time	thDI(1)	0.03								
Serial output	Input clock	Output delay time	tdDO(1)	SO0(P10), SB0(P11)	<ul style="list-style-type: none"> • Continuous data transmission/reception mode • (Note 4-1-3) 	2.4 to 3.6			(1/3)tCYC +0.05	μs	
			tdDO(2)				<ul style="list-style-type: none"> • Synchronous 8-bit mode • (Note 4-1-3) 				1tCYC +0.05
	tdDO(3)	(Note 4-1-3)						(1/3)tCYC +0.05			

Note 4-1-1: These specifications are theoretical values. Be sure to add margin depending on its use.

Note 4-1-2: In an application where the serial clock input is to be used in continuous data transmission/reception mode, the time from SIORUN being set when serial clock is high to the falling edge of the first serial clock must be longer than tSCKHA.

Note 4-1-3: Must be specified with respect to the falling edge of SIOCLK. Must be specified as the time up to the beginning of output state change in open drain output mode. See Fig. 6.

LC87F7932B

2. SIO1 Serial I/O Characteristics (Note 4-2-1)

Parameter	Symbol	Pin/Remarks	Conditions	Specification						
				V _{DD} [V]	min	typ	max	unit		
Serial clock	Input clock	Frequency	tSCK(3)	SCK1(P15)	See Fig. 6.	2.4 to 3.6	2			tCYC
		Low level pulse width	tSCKL(3)				1			
		High level pulse width	tSCKH(3)				1			
	Output clock	Frequency	tSCK(4)	SCK1(P15)	<ul style="list-style-type: none"> • CMOS output selected • See Fig. 6. 	2.4 to 3.6	2			tSCK
		Low level pulse width	tSCKL(4)				1/2			
		High level pulse width	tSCKH(4)				1/2			
Serial input	Data setup time	tsDI(2)	SB1(P14), SI1(P14)	<ul style="list-style-type: none"> • Must be specified with respect to the rising edge of SIOCLK. • See Fig. 6. 	2.4 to 3.6	0.03			μs	
	Data hold time	thDI(2)				0.03				
Serial output	Output delay time	tdDO(4)	SO1(P13), SB1(P14)	<ul style="list-style-type: none"> • Must be specified with respect to the falling edge of SIOCLK. • Must be specified as the time up to the beginning of output state change in open drain output mode. • See Fig. 6. 	2.4 to 3.6			(1/3)tCYC +0.05		

Note 4-2-1: These specifications are theoretical values. Be sure to add margin depending on its use.

Pulse Input Conditions at Ta = -40°C to +85°C, V_{SS1} = V_{SS2} = 0V

Parameter	Symbol	Pin/Remarks	Conditions	Specification				
				V _{DD} [V]	min	typ	max	unit
High/low level pulse width	tPIH(1)	INT0(P70), INT1(P71), INT2(P72)	<ul style="list-style-type: none"> • Interrupt source flag can be set. • Event inputs for timer 0 are enabled. 	2.4 to 3.6	1			tCYC
	tPIL(1)							
	tPIH(2)	INT3(P73) when noise filter time constant is 1/1	<ul style="list-style-type: none"> • Interrupt source flag can be set. • Event inputs for timer 0 are enabled. 	2.4 to 3.6	2			
	tPIL(2)							
	tPIH(3)	INT3(P73) when noise filter time constant is 1/32	<ul style="list-style-type: none"> • Interrupt source flag can be set. • Event inputs for timer 0 are enabled. 	2.4 to 3.6	64			
tPIL(3)								
tPIH(4)	INT3(P73) when noise filter time constant is 1/128	<ul style="list-style-type: none"> • Interrupt source flag can be set. • Event inputs for timer 0 are enabled. 	2.4 to 3.6	256				
tPIL(4)								
tPIL(5)	RES	Resetting is enabled.	2.4 to 3.6	200			μs	

LC87F7932B

AD Converter Characteristics at $V_{SS1} = V_{SS2} = 0V$

<12-bit AD Conversion Mode at $T_a = -40^{\circ}C$ to $+85^{\circ}C$ >

Parameter	Symbol	Pin/Remarks	Conditions	Specification				
				$V_{DD}[V]$	min	typ	max	unit
Resolution	N	AN0 (P00) to AN6 (P71)		3.0 to 3.6		12		bit
Absolute accuracy	ET		(Note 6-1)	3.0 to 3.6			± 16	LSB
Conversion time	TCAD		• See conversion time calculation formulas. (Note 6-2)	3.0 to 3.6	64		115	μs
Analog input voltage range	VAIN			3.0 to 3.6	V_{SS}		V_{DD}	V
Analog port input current	I _{AINH}		$V_{AIN} = V_{DD}$	3.0 to 3.6			1	μA
	I _{AINL}	$V_{AIN} = V_{SS}$	3.0 to 3.6	-1				

<8-bit AD Conversion Mode at $T_a = -40^{\circ}C$ to $+85^{\circ}C$ >

Parameter	Symbol	Pin/Remarks	Conditions	Specification				
				$V_{DD}[V]$	min	typ	max	Unit
Resolution	N	AN0(P00) to AN6(P71)		3.0 to 3.6		8		bit
Absolute accuracy	ET		(Note 6-1)	3.0 to 3.6			± 1.5	LSB
Conversion time	TCAD		• See conversion time calculation formulas. (Note 6-2)	3.0 to 3.6	40		90	μs
Analog input voltage range	VAIN			3.0 to 3.6	V_{SS}		V_{DD}	V
Analog port input current	I _{AINH}		$V_{AIN} = V_{DD}$	3.0 to 3.6			1	μA
	I _{AINL}	$V_{AIN} = V_{SS}$	3.0 to 3.6	-1				

Conversion Time Calculation Formulas:

12-bit AD conversion mode: $TCAD$ (conversion time) = $((52 / (\text{AD division ratio})) + 2) \times (1/3) \times t_{CYC}$

8-bit AD conversion mode: $TCAD$ (conversion time) = $((32 / (\text{AD division ratio})) + 2) \times (1/3) \times t_{CYC}$

<Recommended Operating Conditions>

External Oscillator (F _{mCF})	Supply Voltage Range (V_{DD})	System Clock Division Ratio (SYS _{SDIV})	Cycle Time (t _{CYC})	AD Frequency Division Ratio (ADDIV)	Conversion Time (TCAD)	
					12-bit AD	8-bit AD
CF-4MHz	3.0V to 3.6V	1/1	750ns	1/8	104.5 μs	64.5 μs

Note 6-1: The quantization error ($\pm 1/2LSB$) is excluded from the absolute accuracy. The absolute accuracy is measured in the microcontroller's state in which no I/O operations occur at the pins adjacent to the analog input channel.

Note 6-2: The conversion time refers to the period from the time an instruction for starting a conversion process is executed until the time the conversion result register(s) are loaded with a complete digital conversion value corresponding to the analog input value.

The conversion time is doubled in the following cases:

- The first AD conversion is performed in the 12 bits AD conversion mode after a system reset.
- The first AD conversion is performed after the AD conversion mode is switched from 8 bits to 12 bits conversion mode.

LC87F7932B

Consumption Current Characteristics at Ta = -40°C to +85°C, V_{SS1} = V_{SS2} = 0V

Parameter	Symbol	Pin/Remarks	Conditions	Specification				
				V _{DD} [V]	min	typ	max	unit
Current consumption in normal operating mode (Note 7-1)	IDDOP(1)	V _{DD1} =V _{DD2} =V ₂	<ul style="list-style-type: none"> • FmCF=4MHz ceramic oscillation • FsX'tal=32.768kHz crystal oscillation • System clock set to 4MHz side • Internal RC oscillation stopped • VMRC oscillation stopped • 1/1 frequency division ratio 	2.4 to 3.6		2.0	4.2	mA
	IDDOP(2)		<ul style="list-style-type: none"> • FmCF=0Hz (Oscillation stopped) • FsX'tal=32.768kHz crystal oscillation • System clock set to high-speed internal RC oscillation • VMRC oscillation stopped • 1/1 frequency division ratio 	2.4 to 3.6		250	900	μA
	IDDOP(3)		<ul style="list-style-type: none"> • FmCF=0Hz (Oscillation stopped) • FsX'tal=32.768kHz crystal oscillation • System clock set to low-speed internal RC oscillation • VMRC oscillation stopped • 1/1 frequency division ratio 	2.4 to 3.6		30	120	
	IDDOP(4)		<ul style="list-style-type: none"> • FmCF=0Hz (Oscillation stopped) • FsX'tal=32.768kHz crystal oscillation • Internal RC oscillation stopped • System clock set to 4MHz VMRC oscillation • 1/1 frequency division ratio 	2.4 to 3.6		2.0	5.4	mA
	IDDOP(5)		<ul style="list-style-type: none"> • FmCF=0Hz (Oscillation stopped) • FsX'tal=32.768kHz crystal oscillation • Internal RC oscillation stopped • System clock set to 500kHz VMRC oscillation • 1/1 frequency division ratio 	2.4 to 3.6		250	900	μA
	IDDOP(6)		<ul style="list-style-type: none"> • FmCF=0Hz (Oscillation stopped) • FsX'tal=32.768kHz crystal oscillation • System clock set to 32.768kHz side • Internal RC oscillation stopped • VMRC oscillation stopped • 1/1 frequency division ratio • Normal XT amp mode 	2.4 to 3.6		20	86	
	IDDOP(7)		<ul style="list-style-type: none"> • FmCF=0Hz (Oscillation stopped) • FsX'tal=32.768kHz crystal oscillation • System clock set to 32.768kHz side • Internal RC oscillation stopped • VMRC oscillation stopped • 1/1 frequency division ratio • Low consumption XT amp mode 	2.4 to 3.6		15	72	

Note 7-1: The consumption current value does not include current that flows into the output transistors and internal pull-up resistors.

Continued on next page.

LC87F7932B

Continued from preceding page.

Parameter	Symbol	Pin/Remarks	Conditions	Specification				
				V _{DD} [V]	min	typ	max	unit
Current consumption in HALT mode (Note 7-1)	IDDHALT(1)	V _{DD1} =V _{DD2} =V ₂	HALT mode • FmCF=4MHz ceramic oscillation • FsX'tal=32.768kHz crystal oscillation • System clock set to 4MHz side • Internal RC oscillation stopped • VMRC oscillation stopped • 1/1 frequency division ratio	2.4 to 3.6		0.55	1.55	mA
	IDDHALT(2)		HALT mode • FmCF=0Hz (Oscillation stopped) • FsX'tal=32.768kHz crystal oscillation • System clock set to high-speed internal RC oscillation • VMRC oscillation stopped • 1/1 frequency division ratio	2.4 to 3.6		68	280	μA
	IDDHALT(3)		HALT mode • FmCF=0Hz (Oscillation stopped) • FsX'tal=32.768kHz crystal oscillation • System clock set to low-speed internal RC oscillation • VMRC oscillation stopped • 1/1 frequency division ratio	2.4 to 3.6		7	85	
	IDDHALT(4)		HALT mode • FmCF=0Hz (Oscillation stopped) • FsX'tal=32.768kHz crystal oscillation • Internal RC oscillation stopped • System clock set to 4MHz VMRC oscillation • 1/1 frequency division ratio	2.4 to 3.6		650	1460	
	IDDHALT(5)		HALT mode • FmCF=0Hz (Oscillation stopped) • FsX'tal=32.768kHz crystal oscillation • Internal RC oscillation stopped • System clock set to VMRC oscillation (500kHz) • 1/1 frequency division ratio	2.4 to 3.6		68	280	
	IDDHALT(6)		HALT mode • FmCF=0Hz (Oscillation stopped) • FsX'tal=32.768kHz crystal oscillation • System clock set to 32.768kHz side • Internal RC oscillation stopped. • VMRC oscillation stopped • 1/1 frequency division ratio • Normal XT amp mode	2.4 to 3.6		8	70	
	IDDHALT(7)		HALT mode • FmCF=0Hz (Oscillation stopped) • FsX'tal=32.768kHz crystal oscillation • System clock set to 32.768kHz side • Internal RC oscillation stopped. • VMRC oscillation stopped • 1/1 frequency division ratio • Low consumption XT amp mode	2.4 to 3.6		4	50	

Note 7-1: The consumption current value does not include current that flows into the output transistors and internal pull-up resistors.

Continued on next page.

LC87F7932B

Continued from preceding page.

Parameter	Symbol	Pin/Remarks	Conditions	Specification				
				V _{DD} [V]	min	typ	max	unit
Current consumption in HOLD mode	IDDHOLD(1)	V _{DD1} =V _{DD2} =V2	HOLD mode • CF1=V _{DD} or open (When using external clock)	2.4 to 3.6		0.05	30	μA
Current consumption in time-of-day clock HOLD mode	IDDHOLD(2)	V _{DD1} =V _{DD2} =V2	Time-of-day clock HOLD mode • CF1=V _{DD} or open (When using external clock) • FsX'tal=32.768kHz crystal oscillation • 1/1 frequency division ratio • LCD display off • Normal XT amp mode	2.4 to 3.6		6.5	67	
	IDDHOLD(3)		Time-of-day clock HOLD mode • CF1=V _{DD} or open (When using external clock) • FsX'tal=32.768kHz crystal oscillation • 1/1 frequency division ratio • LCD display off • Low consumption XT amp mode	2.4 to 3.6		0.45	46	
	IDDHOLD(4)		Time-of-day clock HOLD mode • CF1=V _{DD} or open (When using external clock) • FsX'tal=low-speed RC oscillation • 1/1 frequency division ratio • LCD display off	2.4 to 3.6		1.5	70	

LC87F7932B

F-ROM Programming Characteristics at Ta = +10°C to +55°C, VSS1 = VSS2 = 0V

Parameter	Symbol	Pin/Remarks	Conditions	Specification				
				VDD[V]	min	typ	max	unit
Onboard programming current	IDDFW(1)	VDD1	• Excluding power dissipation in the microcontroller block	3.0 to 5.5		5	10	mA
Programming time	tFW(1)		• Erasing operation	3.0 to 5.5		20	30	ms
	tFW(2)		• Programming operation			45	60	μs

UART (Full Duplex) Operating Conditions at Ta = -40°C to +85°C, VSS1 = VSS2 = 0V

Parameter	Symbol	Pin/Remarks	Conditions	Specification				
				VDD[V]	min	typ	max	unit
Transfer rate	UBR	UTX (P00), URX (P01)		2.4 to 3.6	16/3		8192/3	tCYC

Data length: 7/8/9 bits (LSB first)

Stop bits: 1 bit (2 bits in continuous data transmission)

Parity bits: None

Example of 8-bit Data Transmission Mode Processing (Transmit Data=55H)

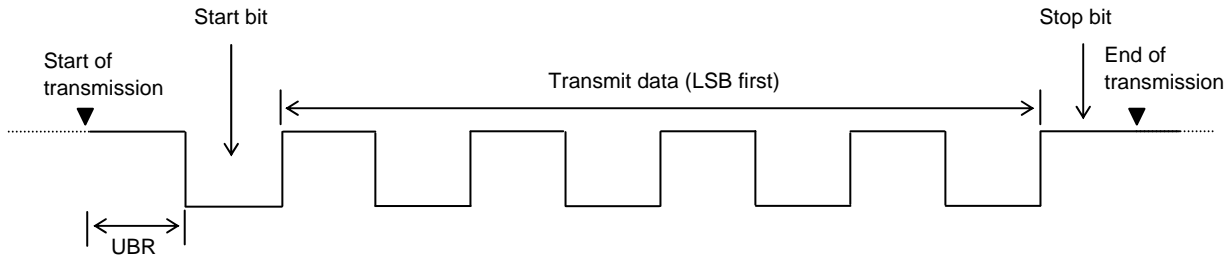

Example of 8-bit Data Reception Mode Processing (Receive Data=55H)

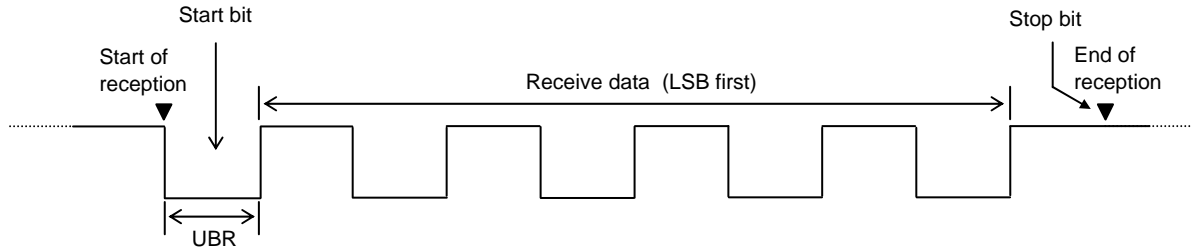

Characteristics of a Sample Main System Clock Oscillator Circuit

Given below are the characteristics of a sample main system clock oscillator circuit, which are measured using a Our designated oscillation characteristics evaluation board and external components with circuit constant values with normal and stable oscillation confirmed by the resonator vendor.

Table 1 Characteristics of a Sample Main System Clock Oscillator Circuit with a Ceramic Resonator

Nominal Frequency	Vendor Name	Resonator Name	Circuit Constant				Operating Voltage Range [V]	Oscillation Stabilization Time		Remarks
			C1 [pF]	C2 [pF]	Rf1 [Ω]	Rd1 [Ω]		typ [ms]	max [ms]	
4.00MHz	Murata	CSTCR4M00G53-R0	(15)	(15)	Open	1k	2.4 to 3.6	0.03	0.15	Internal C1, C2
		CSTLS4M00G53-B0	(15)	(15)	Open	1k	2.4 to 3.6	0.02	0.15	

The oscillation stabilization time is the period required for the resonator to stabilize in the following situations. (See Figure 4)

- After V_{DD} goes above the operating voltage lower limit until the oscillation is stabilized.
- After the instruction for starting the main clock oscillation circuit is executed until the oscillation is stabilized.
- After HOLD mode is released until the oscillation is stabilized.
- After HOLD mode is released and oscillation is started with CFSTOP (OCR register, bit0) set to 0 until the oscillation is stabilized.

Characteristics of a Sample Sub-system Clock Oscillator Circuit

Given below are the characteristics of a sample sub-system clock oscillator circuit, which are measured using a Our designated oscillation characteristics evaluation board and external components with circuit constant values with normal and stable oscillation confirmed by the resonator vendor. (Different evaluation boards are used for Tables 2 and 3.)

Table 2 Characteristics of a Sample Sub-system Clock Oscillator Circuit with a Crystal Resonator 1

Nominal Frequency	Vendor Name	Resonator Name	Circuit Constant				Operating Voltage Range [V]	Oscillation Stabilization Time		Remarks
			C3 [pF]	C4 [pF]	Rf2 [Ω]	Rd2 [Ω]		typ [s]	max [s]	
32.768KHz	Epson Toyocom	MC-306	9	9	Open	330k	2.4 to 3.6	1	3	CL=7.0pF Normal amp
			3	3	Open	0	2.4 to 3.6	2	6	CL=7.0pF Low consumption amp

Table 3 Characteristics of a Sample Sub-system Clock Oscillator Circuit with a Crystal Resonator 2 (*5)

Nominal Frequency	Vendor Name	Resonator Name	Circuit Constant				Operating Voltage Range [V]	Oscillation Stabilization Time		Remarks
			C3 [pF]	C4 [pF]	Rf2 [Ω]	Rd2 [Ω]		typ [s]	max [s]	
32.768kHz (*1)	Seiko Instruments (*2)	SSP-T7-F	22	22	Open	820k	2.4 to 3.6	1.8	3	CL=12.5pF (*3) Normal amp
		VT-200-F								
		SSP-T7-FL	7	6	Open	0	2.4 to 3.6	0.9	3	CL=6.0pF (*4) Low consumption amp
		VT-200-FL								

(*1) Normal XT amplifier mode (*3) or low consumption amplifier mode (*4) should be selected for the sub-system clock oscillator circuit.

(*2) Contact Seiko Instruments, Inc., (<http://www.sii-crystal.com>) for further information about the use of the resonator.

(*3) When considering the use of normal XT amplifier mode, use a resonator that has a large load capacitance.

(*4) When considering the use of low consumption XT amplifier mode, use a resonator that has a small load capacitance. The applicable CL value of 6.0pF makes it possible to achieve a high time accuracy for the subclock oscillator as well as high-speed oscillation startup and low power dissipation. In addition to this value, 7.0pF and 9.0pF also fall within the applicable CL value range.

LC87F7932B

(*5) A sample PCB trace pattern for a Seiko Instrument resonator is shown below.

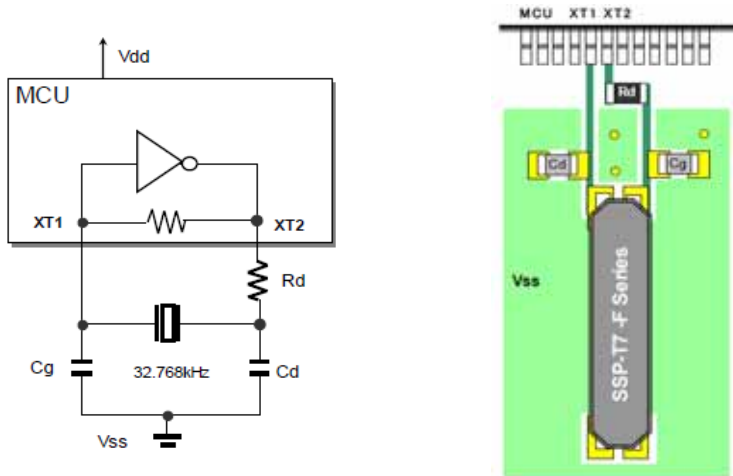

(Note 1) The oscillation stabilization time is the period required for the oscillator to stabilize in the following situations (see Figure 4):

- After the instruction for starting the subclock oscillator circuit is executed until the oscillation is stabilized.
- After HOLD mode is released and oscillation is started with EXTOSC (OCR register, bit 6) set to 1 until the oscillation is stabilized.

(Note 2) The circuit constants shown are the reference values that are provided by the resonator vendor for evaluation. To make final verification of the oscillation characteristics on production boards, call the resonator vendor for evaluation on printed circuit boards.

(Note 3) When using an oscillator circuit, observe the following wiring precautions to avoid the possible adverse influence of wiring capacitance, especially in low consumption XT amplifier mode:

- Place the components that are involved in oscillation as close to the resonator as possible with the shortest possible traces as the oscillation characteristics are subject to the variation of trace patterns.
- Do not take a signal directly from the oscillator circuit.
- Do not place the oscillator circuit in the vicinity of any lines that carry large current.
- Exercise extreme care in the wiring method when using low consumption XT amplifier mode.

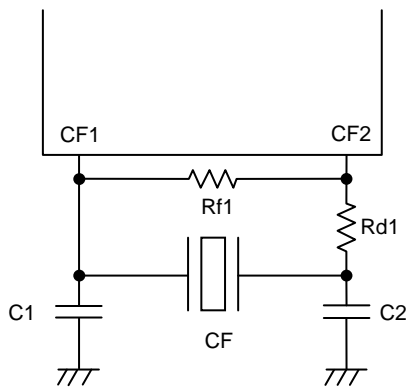

Figure 1 CF Oscillator Circuit

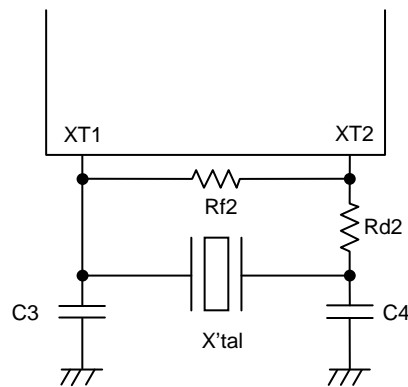

Figure 2 XT Oscillator Circuit

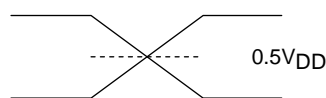
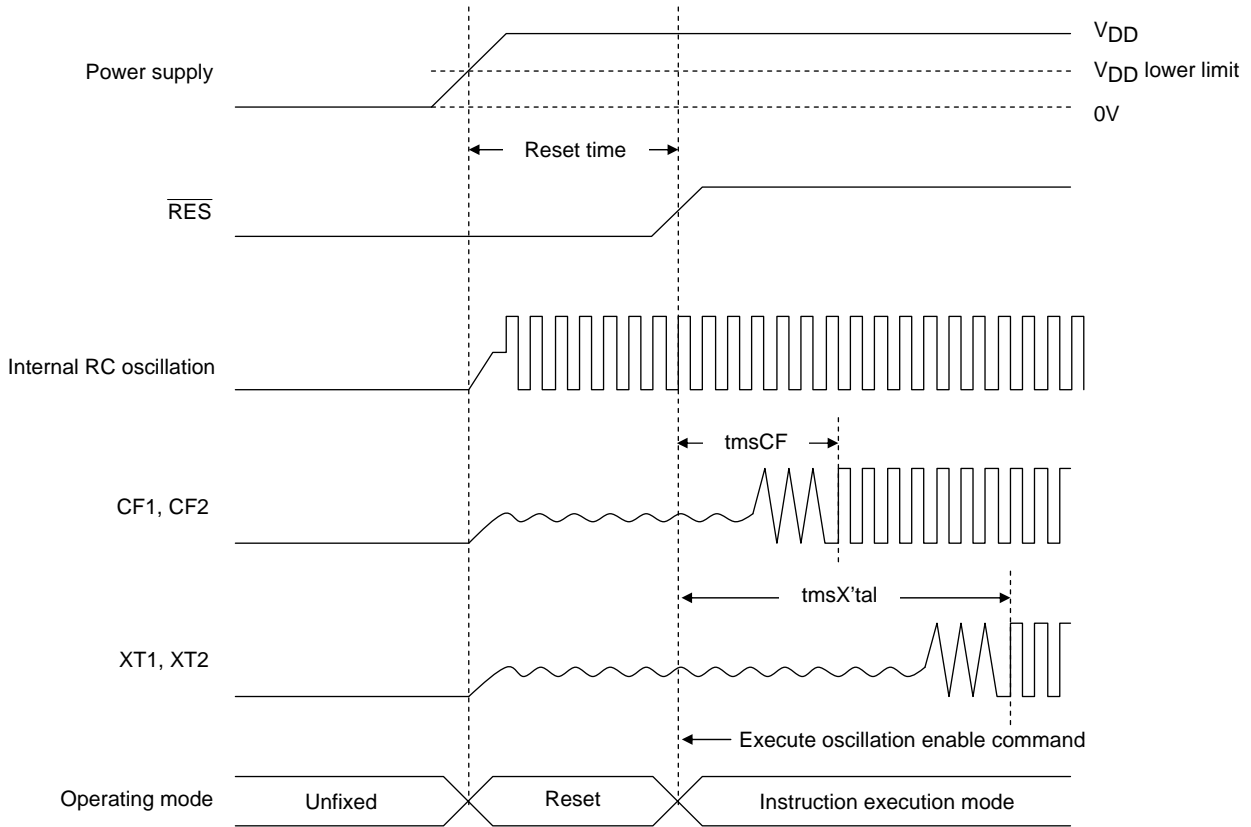
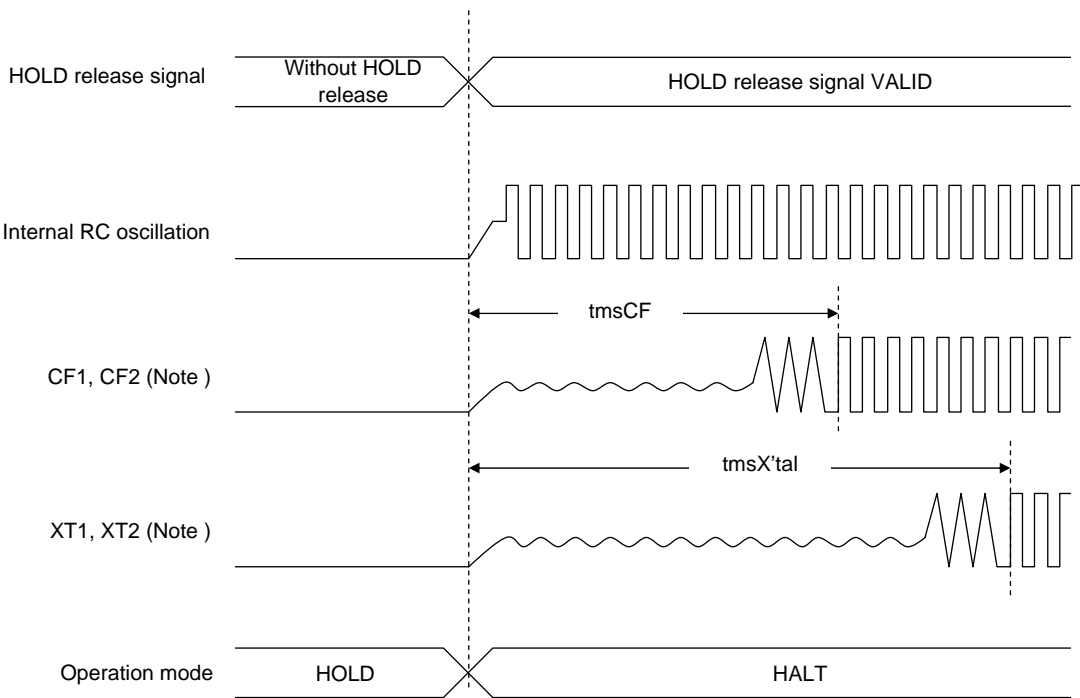

Figure 3 AC Timing Measurement Point



Reset Time and Oscillation Stabilization Time



HOLD Release Signal and Oscillation Stabilization Time

Note: Oscillation is enabled before HOLD mode is entered.

Figure 4 Oscillation Stabilization Time

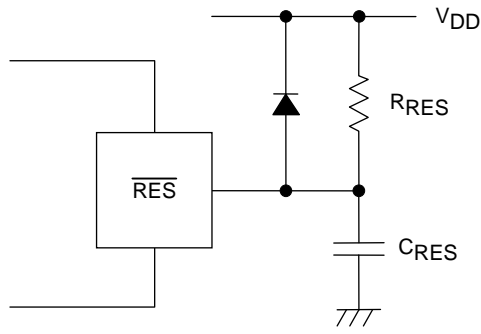

Note:
External circuits for reset may vary depending on the usage of POR. Please refer to the user's manual on reset function.

Figure 5 Reset Circuit

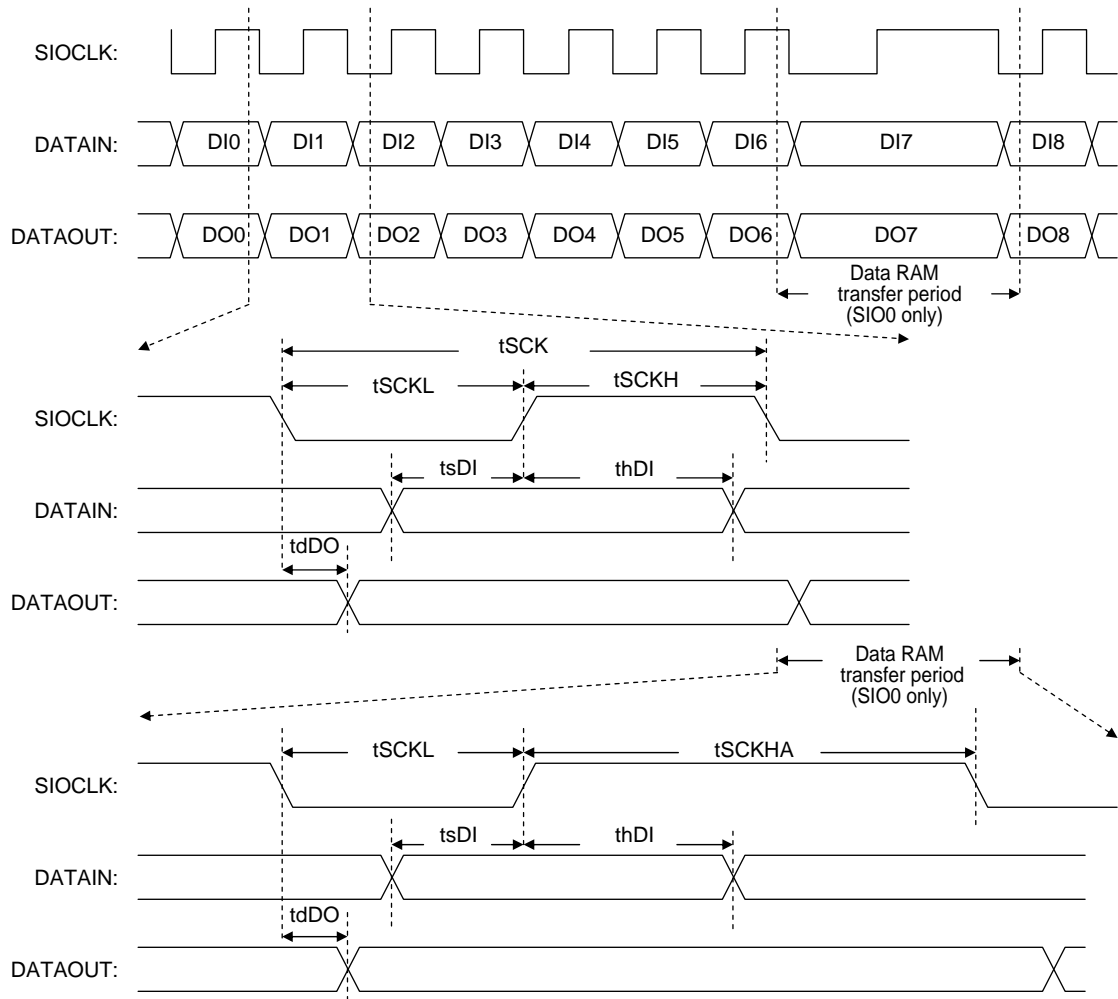

Figure 6 Serial Input/Output Waveform

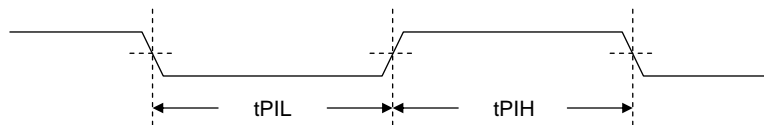

Figure 7 Pulse Input Timing Waveform

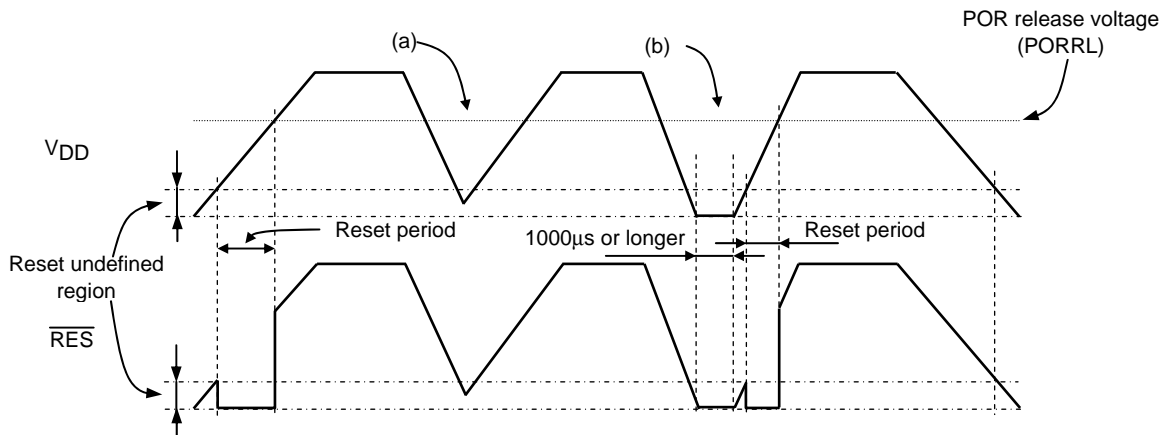

Figure 8 Sample Operating Waveforms when POR is Used
(Reset pin: Pull-up resistor R_{RES} only)

- The POR function generates a reset only when power is turned on starting at the V_{SS} level.
- No stable reset will be generated if power is turned on again when the power level does not go down to the V_{SS} level as shown in (a).
- A reset is generated only when the power level goes down to the V_{SS} level as shown in (b) and power is turned on again after this condition continues for 1000µs or longer.

ON Semiconductor and the ON logo are registered trademarks of Semiconductor Components Industries, LLC (SCILLC). SCILLC owns the rights to a number of patents, trademarks, copyrights, trade secrets, and other intellectual property. A listing of SCILLC's product/patent coverage may be accessed at www.onsemi.com/site/pdf/Patent-Marking.pdf. SCILLC reserves the right to make changes without further notice to any products herein. SCILLC makes no warranty, representation or guarantee regarding the suitability of its products for any particular purpose, nor does SCILLC assume any liability arising out of the application or use of any product or circuit, and specifically disclaims any and all liability, including without limitation special, consequential or incidental damages. "Typical" parameters which may be provided in SCILLC data sheets and/or specifications can and do vary in different applications and actual performance may vary over time. All operating parameters, including "Typicals" must be validated for each customer application by customer's technical experts. SCILLC does not convey any license under its patent rights nor the rights of others. SCILLC products are not designed, intended, or authorized for use as components in systems intended for surgical implant into the body, or other applications intended to support or sustain life, or for any other application in which the failure of the SCILLC product could create a situation where personal injury or death may occur. Should Buyer purchase or use SCILLC products for any such unintended or unauthorized application, Buyer shall indemnify and hold SCILLC and its officers, employees, subsidiaries, affiliates, and distributors harmless against all claims, costs, damages, and expenses, and reasonable attorney fees arising out of, directly or indirectly, any claim of personal injury or death associated with such unintended or unauthorized use, even if such claim alleges that SCILLC was negligent regarding the design or manufacture of the part. SCILLC is an Equal Opportunity/Affirmative Action Employer. This literature is subject to all applicable copyright laws and is not for resale in any manner.

Компания «Океан Электроники» предлагает заключение долгосрочных отношений при поставках импортных электронных компонентов на взаимовыгодных условиях!

Наши преимущества:

- Поставка оригинальных импортных электронных компонентов напрямую с производств Америки, Европы и Азии, а так же с крупнейших складов мира;
- Широкая линейка поставок активных и пассивных импортных электронных компонентов (более 30 млн. наименований);
- Поставка сложных, дефицитных, либо снятых с производства позиций;
- Оперативные сроки поставки под заказ (от 5 рабочих дней);
- Экспресс доставка в любую точку России;
- Помощь Конструкторского Отдела и консультации квалифицированных инженеров;
- Техническая поддержка проекта, помощь в подборе аналогов, поставка прототипов;
- Поставка электронных компонентов под контролем ВП;
- Система менеджмента качества сертифицирована по Международному стандарту ISO 9001;
- При необходимости вся продукция военного и аэрокосмического назначения проходит испытания и сертификацию в лаборатории (по согласованию с заказчиком);
- Поставка специализированных компонентов военного и аэрокосмического уровня качества (Xilinx, Altera, Analog Devices, Intersil, Interpoint, Microsemi, Actel, Aeroflex, Peregrine, VPT, Syfer, Eurofarad, Texas Instruments, MS Kennedy, Miteq, Cobham, E2V, MA-COM, Hittite, Mini-Circuits, General Dynamics и др.);

Компания «Океан Электроники» является официальным дистрибьютором и эксклюзивным представителем в России одного из крупнейших производителей разъемов военного и аэрокосмического назначения «**JONHON**», а так же официальным дистрибьютором и эксклюзивным представителем в России производителя высокотехнологичных и надежных решений для передачи СВЧ сигналов «**FORSTAR**».



JONHON

«**JONHON**» (основан в 1970 г.)

Разъемы специального, военного и аэрокосмического назначения:

(Применяются в военной, авиационной, аэрокосмической, морской, железнодорожной, горно- и нефтедобывающей отраслях промышленности)

«**FORSTAR**» (основан в 1998 г.)

ВЧ соединители, коаксиальные кабели, кабельные сборки и микроволновые компоненты:

(Применяются в телекоммуникациях гражданского и специального назначения, в средствах связи, РЛС, а так же военной, авиационной и аэрокосмической отраслях промышленности).



Телефон: 8 (812) 309-75-97 (многоканальный)

Факс: 8 (812) 320-03-32

Электронная почта: ocean@oceanchips.ru

Web: <http://oceanchips.ru/>

Адрес: 198099, г. Санкт-Петербург, ул. Калинина, д. 2, корп. 4, лит. А