

SPDFCBK-15G / SPDFCBK-16G

DC-DC Power Supplies

The SPDFCBK-15G / SPDFCBK-16G are 750 W/400 W DC-DC power supplies that convert DC input into a main output of 12 VDC for powering intermediate bus architectures (IBA) in high performance and reliability servers, routers, and network switches.

The SPDFCBK-15G / SPDFCBK-16G meet international safety standards and display the CE-Mark for the European Low Voltage Directive (LVD).

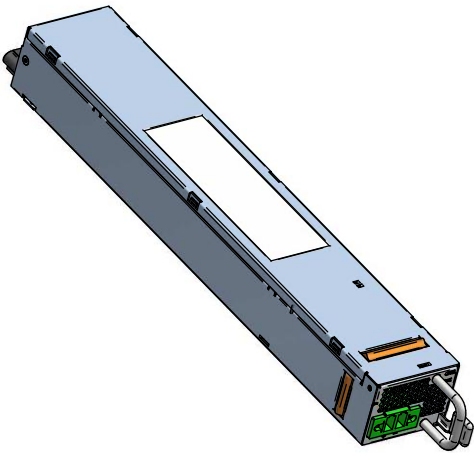

Key Features & Benefits

- Open Compute (OCP) compliant
- Best-in-class, “Platinum level” efficiency
- Wide input voltage range: 40 – 72 VDC
- Always-On 10 W programmable standby output (3.3 V)
- Hot-plug capable
- Parallel operation with active current sharing
- Small form factor: 321.5 x 54.5 x 40 mm (12.66 x 2.14 x 1.57 in)
- I²C communication interface for control, programming and monitoring with PSMI and Power Management Bus protocol
- Overtemperature, output overvoltage and overcurrent protection
- 8160 bytes of EEPROM for user information
- 2 Status LEDs: OK and Fail with fault signaling

Applications

- High Performance Servers
- Routers
- Switches



bel POWER
SOLUTIONS &
PROTECTION

a bel group

belfuse.com/power-solutions

1. ORDERING INFORMATION

MODEL	OUTPUT POWER	DC INPUT	DC OUTPUT	AIRFLOW
SPDFCBK-15G	750 W	-40 to -72 VDC	12 VDC	Front to Rear
SPDFCBK-16G	400 W	-40 to -72 VDC	12 VDC	Front to Rear

2. INPUT SPECIFICATIONS

PARAMETER	CONDITIONS / DESCRIPTION		MIN	NOM	MAX	UNIT
$V_{1\text{nom}}$	Nominal Input Voltage			-54		VDC
V_I	Input Voltage Ranges		Normal operating ($V_{I\text{min}}$ to $V_{I\text{max}}$)			VDC
$I_{I\text{max}}$	Max Input Current				25 12	A_{rms}
I_p	Inrush Current Limitation		$V_{I\text{min}}$ to $V_{I\text{max}}$		20	A_p
Efficiency	$V_{I\text{nom}}$, $0.5 \cdot I_{I\text{nom}}$, $V_{X\text{nom}}$, $T_A = 25\text{ °C}$				92	%
	$V_{I\text{nom}}$, $I_{I\text{nom}}$, $V_{X\text{nom}}$, $T_A = 25\text{ °C}$				88	
T_{hold}	Hold-up Time	V_I @ 100% load, -54 VDC	SPDFCBK-15G	4		ms
			SPDFCBK-16G	2		
		V_{SB} @ 100% load, -54 VDC		20		
Isolation	Input to Chassis				500	VDC
	Input to Output				1500	

3. OUTPUT SPECIFICATIONS

PARAMETER	CONDITIONS / DESCRIPTION		MIN	NOM	MAX	UNIT
Main Output V_1						
$V_{1\text{nom}}$	Nominal Output Voltage	$T_a = -5$ to 55 °C		12		VDC
$V_{1\text{set}}$	Output Voltage Accuracy	50% load, 25 °C Tamb	-1		+1	% $V_{1\text{nom}}$
$P_{1\text{nom}}$	Nominal Output Power	$V_1 = 12\text{ VDC}$, $T_a = -5$ to 55 °C		744 396		W
$I_{1\text{nom}}$	Nominal Output Current	$V_1 = 12\text{ VDC}$, $T_a = -5$ to 55 °C		62 33		ADC
$dV_{1\text{Load}}$	Load Regulation	0 to 100% load, $V_{1\text{nom}}$			240	mV
$dV_{1\text{Line}}$	Line Regulation	$V_{I\text{min}}$ - $V_{I\text{max}}$, 100% load		± 100		mV
$I_{1\text{max}}$	Current Limitation		65		81	ADC
	Thermal Drift	After 15 min warm up period		± 0.1		% / °C
	Periodic and Random Deviation (PARD)	CM Mode 20 MHz CM Mode 500 MHz		120* 400*		mVpp
$dV_{1\text{dyn}}$	Dynamic Load Regulation	$\Delta I_1 = 50\% I_{1\text{nom}}$, $I_1 = 5 \dots 100\% I_{1\text{nom}}$, $dI_1/dt = 1\text{ A}/\mu\text{s}$, recovery within 1% of $V_{1\text{nom}}$	-0.36		0.36	V
T_{rec}	Recovery Time				1000	μs
	Turn-on Overshoot	$V_{1\text{nom}}$			2	%
dI_{share}	Current Share (Active)	$V_1: 8\text{ V @ }62\text{ A}$ and $0\text{ V @ }0\text{ A}$ $V_1: 4.3\text{ V @ }33\text{ A}$ and $0\text{ V @ }0\text{ A}$		SPDFCBK-15G SPDFCBK-16G		
	Remote Sense	Cable Drop @ Maximum Load			200	mV
	No Load				± 1.0	%
$t_{V_1\text{rise}}$	Rise Time	$V_1 = 10 \dots 90\% V_{1\text{nom}}$			500	ms
	Power-on-Delay	From insertion of DC -40 to -72 V with PS_ON/L asserted			3	s
C_{Load}	Capacitive Loading	$T_a = 25\text{ °C}$			11 000	μF

Standby Output V_{SB}					
$V_{SB\ nom}$	Nominal Output Voltage		3.3		VDC
$V_{SB\ set}$	Output Voltage Accuracy		-2	+2	% $V_{I\ nom}$
$P_{SB\ nom}$	Nominal Output Power		10		W
$I_{SB\ nom}$	Nominal Output Current	$V_{SB} = 3.3\ VDC$	3		ADC
	Load Regulation	0 to 100% load, $V_{I\ nom}$		66	mV
	Periodic and Random Deviation (PARD)	CM Mode 20 MHz CM Mode 500 MHz	50* 250*		mVpp
$dV_{SB\ dyn}$	Dynamic Load Regulation	$\Delta I_{SB} = 50\% I_{SB\ nom}$, $I_{SB} = 5 \dots 100\% I_{SB\ nom}$, $dI_{O}/dt = 0.5\ A/\mu s$, recovery within 1% of $V_{I\ nom}$	-0.1	0.1	V
T_{rec}	Recovery Time			250	μs
	Current Share (Passive)	V_{SB} : total droop of 40 mV from no load to full load			
	No Load			± 2.0	%
$t_{V_{SB}\ rise}$	Rise Time	$V_{SB} = 10 \dots 90\% V_{SB\ nom}$		500	ms
	Power-on-Delay	From insertion of DC -40 to -72 V		2	s
Q_{load}	Capacitive Loading	$T_{amb} = 25\ ^\circ C$		1000	μF

* measured with and without additional filter 10nF/10uF, at 25°C_{amb}, over line and load with a resistive load (not an electronic load)

4. PROTECTION SPECIFICATIONS

PARAMETER	DESCRIPTION / CONDITION	MIN	NOM	MAX	UNIT
Input Fuse	Not user-accessible, quick-acting		30		A
Output Over-Current	$V_{I} = 12\ V$, hiccup when PSU is in short circuit $V_{SB} = 3.3\ V$			200	ms
Overvoltage Threshold on V_{I}		13.3		14.5	V _{DC}
Overvoltage Latch-off time on V_{I}				1	ms
Overvoltage Threshold on V_{SB}		3.6		3.9	V _{DC}
Overvoltage Latch-off time on V_{SB}				1	ms
Input Low Line	Turn-On Voltage Turn-Off Voltage	-40 -37	-41 -38	-42 -39	V

5. SIGNAL, MONITORING & CONTROL SPECIFICATIONS

5.1 Status signals

CONDITION	STATUS SIGNALS					LEDS	
	Input OK/H	PWOK/H	PSON/L	PRESENT/L	PS KILL	PWR OK	FAIL
(Assuming 2 or more power supplies present and ON and STBY shared for management interface)							
No problems and power supply is on	1	1	0	0	0	Solid green	off
V1 12V Over current	1	0	0	0	0	off	Solid amber
DC input fail	0	0	0	0	0	off	off
UV on V1 and PS has latched off	1	0	0	0	0	off	Solid amber
UV on VSB and the V1 is latched off	1	0	0	0	0	off	Solid amber
OV on V1 or VSB and PS has latched off (UV set as output off)	1	0	0	0	0	off	Solid amber
Over temperature shutdown and PS has turned off	1	0	0	0	0	off	Solid amber
Fan error (>15%)	1	0	0	0	0	off	Solid amber
Over temperature warning	1	1	0	0	0	off	1Hz blinking
PSON High (VSB on)	1	0	1	0	0	1Hz blinking	off
Fan blocked or running under speed (5-15%) but outputs still within spec and not over temp. This is a warning condition.						off	1Hz blinking
Redundant operation (2 or more power supplies in parallel) – PSU1 operating; PSU2 has input power removed. Till input power from PSU1 is removed.	1	1	0	0	0	off (PSU2)	off (PSU2)

5.2 GRAPHICAL USER INTERFACE

The Bel Power Solutions provides with its “I²C Utility” a Windows® XP/Vista/Win7 compatible graphical user interface allowing the programming and monitoring of the SPDFCBK-15G / SPDFCBK-16G Front-End. The utility can be downloaded on www.belpowersolutions.com and supports both the PSMI and Power Management Bus protocols.

The GUI allows automatic discovery of the units connected to the communication bus and will show them in the navigation tree. In the monitoring view the power supply can be controlled and monitored.

If the GUI is used in conjunction with the SPDFCBK-15G / SPDFCBK-16G Evaluation Kit it is also possible to control the PSON pin(s) of the power supply.

Further there is a button to disable the internal fan for approximately 5 seconds (not implemented yet). This allows the user to take input power measurements without fan consumptions to check efficiency compliance to the Climate Saver Computing Platinum specification.

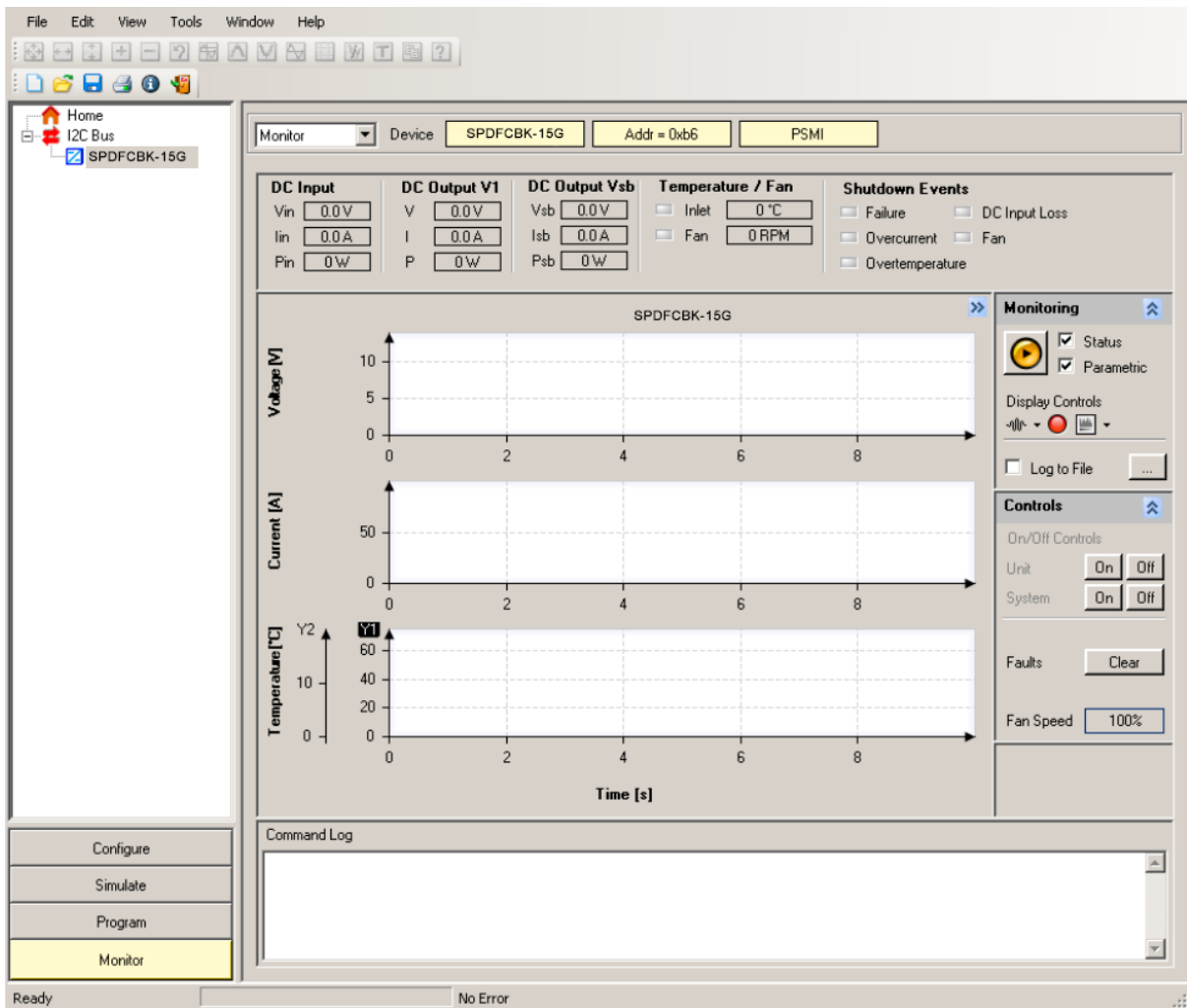

The monitoring screen also allows to enable the hot-standby mode on the power supply. The mode status is monitored and by changing the load current it can be monitored when the power supply is being disabled for further energy savings. This obviously requires 2 power supplies being operated as a redundant system (like the evaluation kit).

NOTE: The user of the GUI needs to ensure that only one of the power supplies have the hot-standby mode enabled.

6. SAFETY SPECIFICATIONS

Approved to the latest edition of the following standards: UL/CSA60950-1, IEC60950-1 and EN60950-1.

7. ELECTROMAGNETIC COMPATIBILITY

7.1 IMMUNITY

TEST	STANDARD / DESCRIPTION	CRITERIA
ESD Contact Discharge	IEC / EN 61000-4-2, ± 8 kV, 25+25 discharges per test point (metallic case, LEDs, connector body)	B
ESD Air Discharge	IEC / EN 61000-4-2, ± 15 kV, 25+25 discharges per test point (non-metallic user accessible surfaces)	B
Radiated Electromagnetic Field	IEC / EN 61000-4-3, 10 V/m, 1 kHz/80% Amplitude Modulation, 1 μ s Pulse Modulation, 10 kHz...2 GHz	A
Electrical Fast Transient / Burst	IEC / EN 61000-4-4, level 3 Input DC port ± 2 kV, 1 minute	B
Surge	IEC / EN 61000-4-5 Line to earth: ± 1 kV Line to line: ± 1 kV	A
RF Conducted Immunity	IEC/EN 61000-4-6, Level 3, 10 Vrms, CW, 0.1 ... 80 MHz	A

7.2 EMISSION

TEST	STANDARD / DESCRIPTION	CRITERIA
Conducted Emission	EN55022 / CISPR 22: single unit, @ -54 VDC, full load	Class A 6 dB margin
	EN55022 / CISPR 22: 2 units in rack system, @ -54 VDC, full load of single unit	Class A 6 dB margin
Radiated Emission	EN55022 / CISPR 22: single unit, @ -54 VDC, full load	Class A 6 dB margin
	EN55022 / CISPR 22: 2 units in rack system, @ -54 VDC, full load of single unit	Class A 6 dB margin

8. ENVIRONMENTAL SPECIFICATIONS

PARAMETER	DESCRIPTION / CONDITION	MIN	NOM	MAX	UNIT
Temperature	Operating	-5		+55	°C
	Non-Operating	-40		+85	
Humidity	Operating	0		90	%RH
	Non-Operating (non-condensing)		95		
Altitude	Operating with no degradation			4000	m
		up to 40°C		1800	
Shock	Operating: three half-sine mechanical shocks 30G with pulse width 16 mm				
	Non-operating: half-sine mechanical shocks 30G with pulse width 16 mm, 18 shocks in three axis in both directions				
Vibration	Operating: Swept Sine 1G peak, 5-500-5Hz				
	Non-operating: Swept Sine 4G peak, 5-500-5Hz				
Audible Noise	Sound power @ V_{nom} , 50% load, $T_A = 27^\circ\text{C}$			53	dBA

9. MECHANICAL SPECIFICATIONS

PARAMETER	DESCRIPTION / CONDITION	MIN	NOM	MAX	UNIT
Dimensions	Width		54.5		
	Height		40.0		mm
	Depth		321.55		
<i>M</i>	Weight		0.918		kg

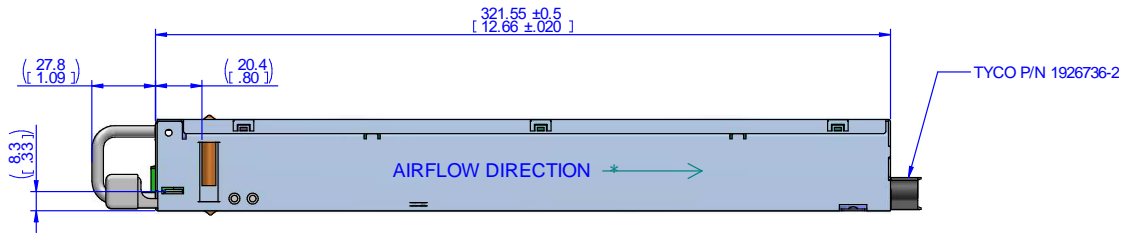

Figure 1. Side View 1

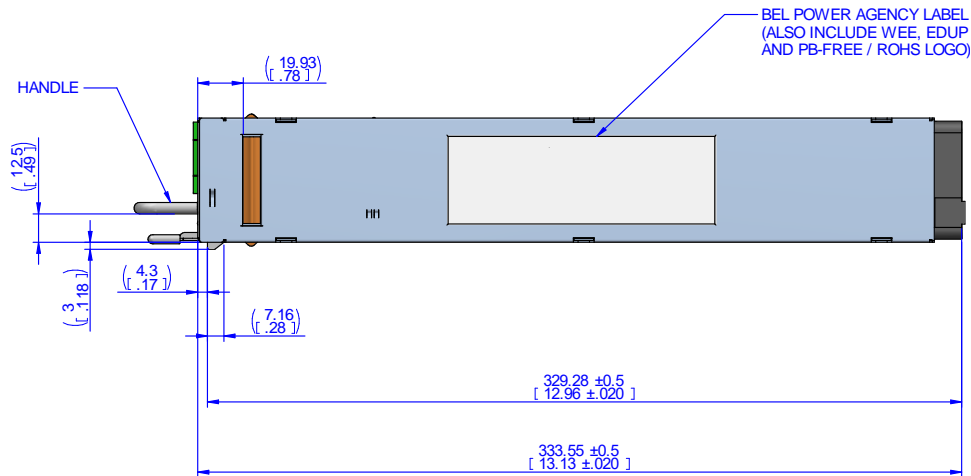

Figure 2. Top View

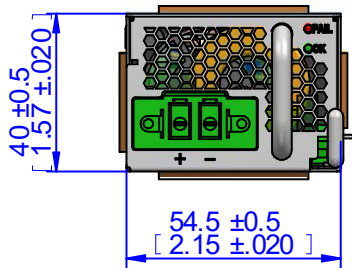

Figure 3. Front View

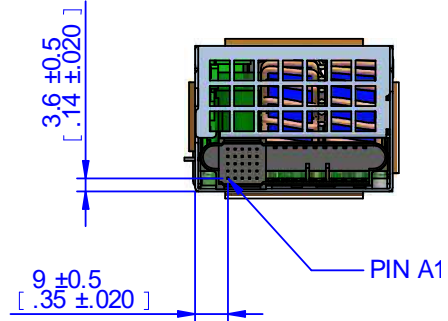

Figure 4. Rear View

10. CONNECTIONS

10.1 INPUT CONNECTOR

PIN	NAME	DESCRIPTION
1	V_RTN	Input voltage (positive)
2	V_IN	Input power ground (return)

Unit: PHOENIX CONTACT, PC 5/2-GF-7.62
 Counter part: PHOENIX CONTACT, PC 5/2-STF-7.62 BD

10.2 OUTPUT CONNECTOR

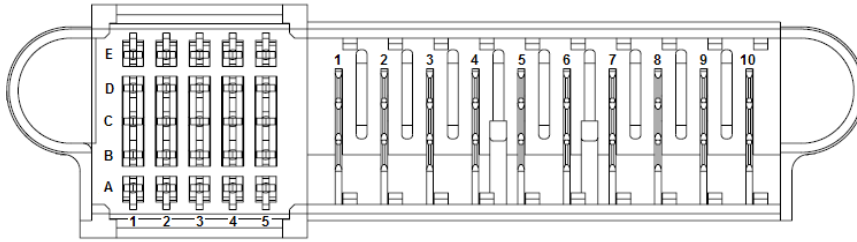



Unit: Tyco Electronics P/N 2-1926736-2
Counter part: Tyco Electronics P/N 2-1926733-5

NOTE: Column 5 is lagging (short pins)

PIN	SIGNAL NAME	DESCRIPTION	AMPS PER PIN
1	PGND	Power ground (return)	25
2	PGND	Power ground (return)	25
3	PGND	Power ground (return)	25
4	PGND	Power ground (return)	25
5	PGND	Power ground (return)	25
6	V1	+12 VDC main output	25
7	V1	+12 VDC main output	25
8	V1	+12 VDC main output	25
9	V1	+12 VDC main output	25
10	V1	+12 VDC main output	25
A1	VSB	Standby positive output (+3.3V)	
B1	VSB	Standby positive output (+3.3V)	
C1	VSB	Standby positive output (+3.3V)	
D1	VSB	Standby positive output (+3.3V)	
E1	VSB	Standby positive output (+3.3V)	
A2	SGND	Signal ground (return)	
B2	SGND	Signal ground (return)	
C2	nc	No connect	
D2	nc	No connect	
E2	nc	No connect	
A3	PSKILL	Power supply kill (lagging pin)	
B3	nc	No connect	
C3	SDA	I2C data signal line	
D3	V1_SENSE_R	Main output negative sense	
E3	V1_SENSE	Main output positive sense	
A4	SCL	I2C clock signal line	
B4	PSON	PS on input connect (referenced to A2/B2)	
C4	SMB_ALERT	SMB Alert signal output	
D4	ISHARE	Current share signal	
E4	INPUT_OK	DC input OK signal	
A5	A0	Address 0	
B5	nc	No connect	
C5	PWOK	Power OK signal output	
D5	A1	Address 1	
E5	PRESENT_L	Power supply present	

Table 2. Pin Description

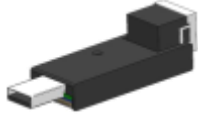
11. ACCESSORIES

ITEM	DESCRIPTION	ORDERING PART NUMBER	SOURCE
	I²C Utility Windows XP/Vista/7 compatible GUI to program, control and monitor Front-Ends (and other I ² C units)	N/A	belfuse.com/power-solutions
	USB to I²C Converter Master I ² C device to program, control and monitor I ² C units in conjunction with the <i>I²C Utility</i>	ZM-00056	Bel Power Solutions
	Dual Connector Board Connector board to operate 2 units in parallel. Includes an on-board USB to I ² C converter (use <i>I²C Utility</i> as desktop software)	SNP-OP-BOARD-01	Bel Power Solutions

For more information on these products consult: tech.support@psbel.com

NUCLEAR AND MEDICAL APPLICATIONS - Products are not designed or intended for use as critical components in life support systems, equipment used in hazardous environments, or nuclear control systems.

TECHNICAL REVISIONS - The appearance of products, including safety agency certifications pictured on labels, may change depending on the date manufactured. Specifications are subject to change without notice.



Asia-Pacific
+86 755 298 85888

Europe, Middle East
+353 61 225 977

North America
+1 408 785 5200

Компания «Океан Электроники» предлагает заключение долгосрочных отношений при поставках импортных электронных компонентов на взаимовыгодных условиях!

Наши преимущества:

- Поставка оригинальных импортных электронных компонентов напрямую с производств Америки, Европы и Азии, а так же с крупнейших складов мира;
- Широкая линейка поставок активных и пассивных импортных электронных компонентов (более 30 млн. наименований);
- Поставка сложных, дефицитных, либо снятых с производства позиций;
- Оперативные сроки поставки под заказ (от 5 рабочих дней);
- Экспресс доставка в любую точку России;
- Помощь Конструкторского Отдела и консультации квалифицированных инженеров;
- Техническая поддержка проекта, помощь в подборе аналогов, поставка прототипов;
- Поставка электронных компонентов под контролем ВП;
- Система менеджмента качества сертифицирована по Международному стандарту ISO 9001;
- При необходимости вся продукция военного и аэрокосмического назначения проходит испытания и сертификацию в лаборатории (по согласованию с заказчиком);
- Поставка специализированных компонентов военного и аэрокосмического уровня качества (Xilinx, Altera, Analog Devices, Intersil, Interpoint, Microsemi, Actel, Aeroflex, Peregrine, VPT, Syfer, Eurofarad, Texas Instruments, MS Kennedy, Miteq, Cobham, E2V, MA-COM, Hittite, Mini-Circuits, General Dynamics и др.);

Компания «Океан Электроники» является официальным дистрибьютором и эксклюзивным представителем в России одного из крупнейших производителей разъемов военного и аэрокосмического назначения «JONHON», а так же официальным дистрибьютором и эксклюзивным представителем в России производителя высокотехнологичных и надежных решений для передачи СВЧ сигналов «FORSTAR».



JONHON

«JONHON» (основан в 1970 г.)

Разъемы специального, военного и аэрокосмического назначения:

(Применяются в военной, авиационной, аэрокосмической, морской, железнодорожной, горно- и нефтедобывающей отраслях промышленности)

«FORSTAR» (основан в 1998 г.)

ВЧ соединители, коаксиальные кабели, кабельные сборки и микроволновые компоненты:

(Применяются в телекоммуникациях гражданского и специального назначения, в средствах связи, РЛС, а так же военной, авиационной и аэрокосмической отраслях промышленности).



Телефон: 8 (812) 309-75-97 (многоканальный)

Факс: 8 (812) 320-03-32

Электронная почта: ocean@oceanchips.ru

Web: <http://oceanchips.ru/>

Адрес: 198099, г. Санкт-Петербург, ул. Калинина, д. 2, корп. 4, лит. А