

NOTES:

- DRAWING TO BE INTERPRETED IN ACCORDANCE WITH THE CURRENT REVISION OF ASME Y14.5.
- THIS PART/PRODUCT IS TO BE MANUFACTURED WITH THE LATEST APPLICABLE REGULATIONS OF EC DIRECTIVES FOR THE RESTRICTION OF THE USE OF HAZARDOUS SUBSTANCES IN ELECTRICAL AND ELECTRONIC EQUIPMENT (ROHS), WASTE ELECTRICAL AND ELECTRONIC EQUIPMENT (WEEE) AND REGISTRATION, EVALUATION, AUTHORIZATION AND RESTRICTION OF CHEMICALS (REACH).
- OUTPUTS ARE FROM THE CENTER TO THE FULL TRAVEL POSITION.
 OPTIONS "AA", "BB", "CC", "DD", "EE", "FF" PROVIDE INCREASED VOLTAGE IN +Y; AND DECREASING VOLTAGE IN -Y DIRECTION FROM ONE OUTPUT PER AXIS.
 OPTIONS "GG" AND "HH" PROVIDE INCREASING VOLTAGES IN ALL DIRECTIONS (+Y, -Y) FROM 2 OUTPUTS PER AXIS.
- OPTIONS "BB" AND "EE" PROVIDE REDUNDANT OUTPUT 2 WHICH DUPLICATES OUTPUT 1.
 OPTIONS "CC" AND "FF" PROVIDE REDUNDANT OUTPUT 2 WHICH IS INVERSE OF OUTPUT 1.
- SEE PAGE 3 FOR ALTERNATE BUTTON DESIGN. ONLY BUTTON STYLE "2", "5", AND "6" ARE OFFERED WITH A WATERTIGHT PANEL SEAL.
- MARKING TO INCLUDE:
 "OTTO" P/N & DATE CODE "YYWW".

HTL2-

HTL2-

REV	OCN #	DATE	APR
A	044213	17 JUL 08	LBG
B	046891	19 JAN 09	LBG
C	063013	19 SEP 11	DCF
D	063582	28 OCT 11	KLW
E	066712	27 JUL 12	DCF
F	070736	31 MAY 13	DCF
G	071505	08 AUG 13	DCF

- 5** BUTTON STYLE
 1 = CASTLE
 2 = EXTERNAL CASTLE BOOT
 3 = SHORT DOUBLE STADIUM
 4 = TALL CONCAVE STADIUM
 5 = EXTERNAL BAT HANDLE BOOT
 6 = EXTERNAL SMOOTH BOOT
 7 = LONG CONCAVE Y AXIS BUTTON
- CASE STYLE**
 1 = .970 SQ.
- 5** SEAL
 1 = DUSTTIGHT
 2 = WATERTIGHT
- TRAVEL**
 1 = 25 DEGREES
- GATING**
 1. SINGLE AXIS
- OPERATE FORCE**
 1 = 16 OZ
- OUTPUT 1** **3**
 AA = 2.5+/-2.0 VDC
 BB = 2.5+/-2.0 VDC
 CC = 2.5+/-2.0 VDC
 DD = 2.5+/-1.5 VDC
 EE = 2.5+/-1.5 VDC
 FF = 2.5+/-1.5 VDC
 GG = 0.5-4.5 VDC
 HH = 1-4 VDC
- OUTPUT 2** **4**
 NONE
 2.5+/-2.0 VDC
 2.5+/-2.0 VDC
 NONE
 2.5+/-1.5 VDC
 2.5+/-1.5 VDC
 0.5-4.5 VDC
 1-4 VDC
- TERMINATION**
 1 = WIRE LEADS, 22 AWG, UL1569
 2 = PINS
 3 = WIRE LEADS, 24 AWG, SAE AS22759
- BUTTON COLOR**
 2 = BLACK

PRODUCT SPECIFICATIONS

ELECTRICAL:

RATED AT V _{cc} = 5V @ 20°C LOAD = 1ma (4.7KΩ)	UNITS	MIN	TYP	MAX
SUPPLY VOLTAGE, V _{cc}	VDC	4.50	5.00	5.50
OUTPUT VOLTAGE TOLERANCE AT CENTER (SEE APPROPRIATE GRAPH FOR OUTPUT VALUES)	VDC @5V V _{cc}	-.25	NA	+.25
OUTPUT VOLTAGE TOLERANCE FULL TRAVEL (SEE APPROPRIATE GRAPH FOR OUTPUT VALUES)	VDC @5V V _{cc}	-.25	NA	+.25
SUPPLY CURRENT PER SENSOR B=0, V _{cc} =5V, I _{out} =0	mA	NA	NA	10.0
OUTPUT SOURCE CURRENT LIMIT B=X*, V _o =0	mA	-1.00	NA	1.00
OUTPUT RESISTANCE I _o < -2 mA	Ω	NA	1.00	10.00

MECHANICAL:

MECHANICAL LIFE ALL DIRECTIONS	1,000,000 CYCLES			
TRAVEL ANGLE	DEGREES	23	25	27
OPERATING FORCE (W/BOOT) AT TOP OF BUTTON, @ 20°C	OZ	NA	16	20
MAX. ALLOWABLE VERTICAL FORCE ON BUTTON	LBS	NA	NA	25
MAX. ALLOWABLE RADIAL FORCE ON BUTTON	LBS	NA	NA	25
MAX. ALLOWABLE TORQUE ON BUTTON ABOUT SHAFT AXIS	IN-LBS	NA	NA	5.5

ENVIRONMENTAL:

OPERATING TEMPERATURE	°C	-40	20	85
ELECTRONICS SEAL INTEGRITY	WATERTIGHT PER IP68S, 1 METER			
EMI/RFI WITHSTAND	PER SAE J1113 CONTACT FACTORY FOR DETAILS			

MATERIAL:

BOOT	ELASTOMER, BLACK
BUTTON	THERMOPLASTIC, BLACK
CASE	THERMOPLASTIC, BLACK
FLANGE	THERMOPLASTIC, BLACK
HARDWARE	4X ITW FASTEX PANEL FASTENER P/N 36030002, OR EQUIVALENT



PINS NOT PRESENT IN ALL CONFIGURATIONS

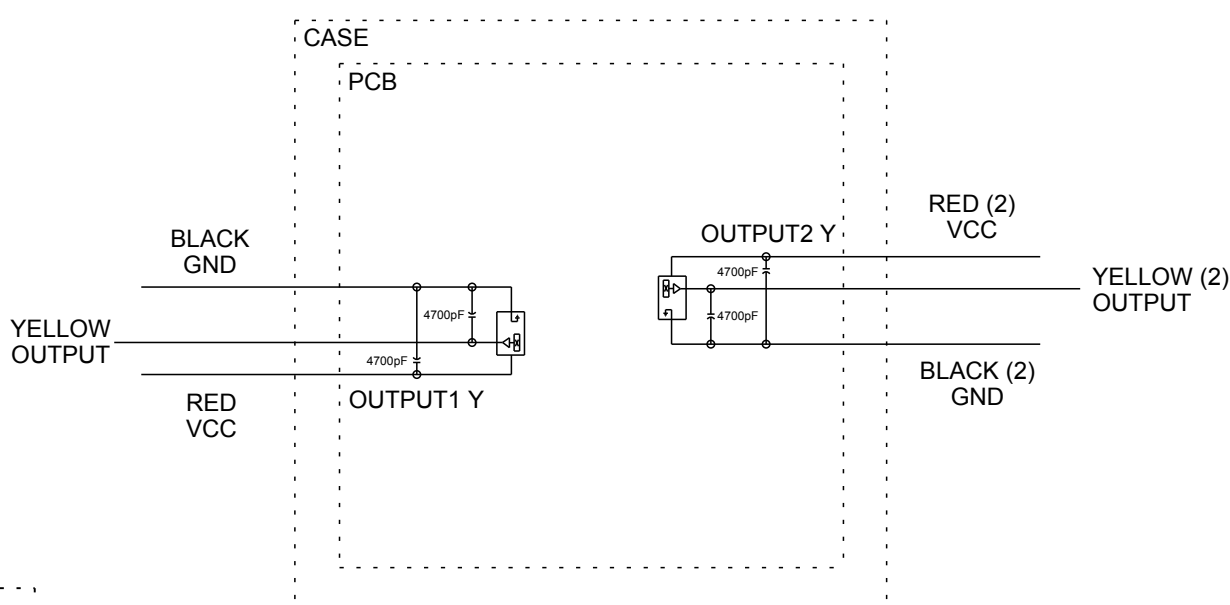

DETAIL A

SCALE 4:1
ALL PINS NOT PRESENT IN ALL CONFIGURATIONS

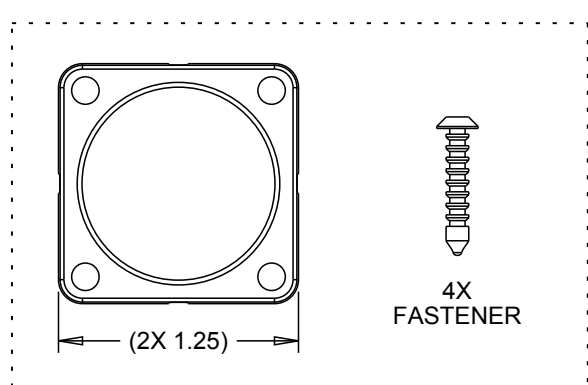

SHIPPED UNASSEMBLED

ALL WIRES NOT PRESENT IN ALL CONFIGURATIONS

OUTPUT2 NOT PRESENT IN ALL CONFIGURATIONS

UNLESS OTHERWISE SPECIFIED:
DIMENSIONS ARE IN INCHES.
TOLERANCES:
.XX ±.03
.XXX ±.010
ANGLES ±2°
DO NOT SCALE

KEY CHARACTERISTICS
SPECIAL REQUIREMENT

OTTO
CARPENTERSVILLE, ILLINOIS USA

DESCRIPTION
HTL2, LINEAR HALL EFFECT
2-WAY TOGGLE

DRWN. JLW	SIZE C	FSCM NO 21649	DRAWING NO. HTL2-	REV. G
CHKD. MRM				
APPD. AH				

OPTION AA



OPTION BB



OPTION CC



OPTION DD



OPTION EE



OPTION FF



OPTION GG



OPTION HH



UNLESS OTHERWISE SPECIFIED
DIMENSIONS ARE IN INCHES.
TOLERANCES ARE AS LISTED.
MUST BE FREE FROM BURRS
AND SHARP EDGES

TOLERANCES
.XX ±.03
.XXX ±.010
ANGLES ±2°
DO NOT SCALE DRAWING

THIS DOCUMENT IS THE CONFIDENTIAL
PROPERTY OF OTTO ENGINEERING, INC..
IT IS NOT TO BE USED IN ANY WAY
DETRIMENTAL TO THE INTERESTS
OF OTTO ENGINEERING, INC.

DRWN. JLW	SIZE C	FSCM NO. 21649	DRAWING NO. HTL2-
CHKD. MRM			
APPD. AH			
WT.	THIRD ANGLE PROJECTION	Scale 1:1	Sheet 2 OF 4

REV. G

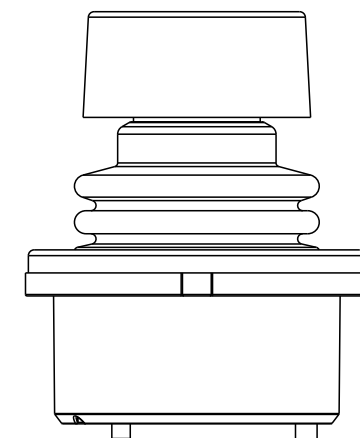
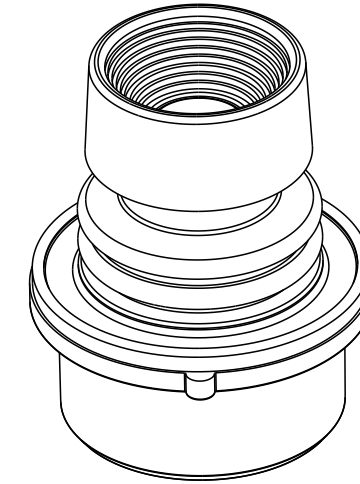

BUTTON STYLE 1
(CASTLE)

BUTTON STYLE 2
(EXTERNAL CASTLE BOOT)

BUTTON STYLE 3
(SHORT DOUBLE STADIUM)

BUTTON STYLE 4
(TALL CONCAVE STADIUM)

BUTTON STYLE CONFIGURATION

UNLESS OTHERWISE SPECIFIED DIMENSIONS ARE IN INCHES. TOLERANCES ARE AS LISTED. MUST BE FREE FROM BURRS AND SHARP EDGES	TOLERANCES		THIS DOCUMENT IS THE CONFIDENTIAL PROPERTY OF OTTO ENGINEERING, INC.. IT IS NOT TO BE USED IN ANY WAY DETRIMENTAL TO THE INTERESTS OF OTTO ENGINEERING, INC.	DRWN. JLW	SIZE	FSCM NO	DRAWING NO.	REV.
	.XX	±.03		CHKD. DCF	C	21649	HTL2-_____	G
	.XXX	±.010		APPD. AH				
	ANGLES ±2°	DO NOT SCALE DRAWING		WT.	THIRD ANGLE PROJECTION	Scale 1:1	Sheet 3 OF 4	



BUTTON STYLE 5
(EXTERNAL BAT
HANDLE BOOT)



BUTTON STYLE 6
(EXTERNAL SMOOTH BOOT)

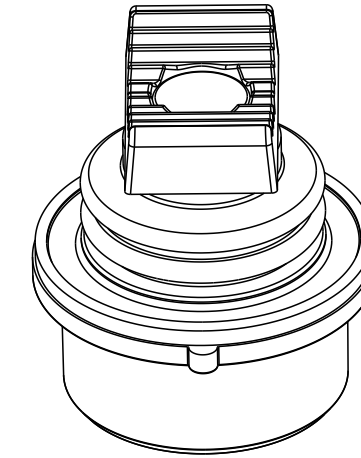

BUTTON STYLE 7
(LONG CONCAVE Y AXIS BUTTON)



BUTTON STYLE CONFIGURATION

UNLESS OTHERWISE SPECIFIED
DIMENSIONS ARE IN INCHES.
TOLERANCES ARE AS LISTED.
MUST BE FREE FROM BURRS
AND SHARP EDGES

TOLERANCES
.XX ±.03
.XXX ±.010
ANGLES ±2°
DO NOT SCALE DRAWING

THIS DOCUMENT IS THE CONFIDENTIAL
PROPERTY OF OTTO ENGINEERING, INC..
IT IS NOT TO BE USED IN ANY WAY
DETRIMENTAL TO THE INTERESTS
OF OTTO ENGINEERING, INC..

DRWN. JLW
CHKD. DCF
APPD. AH
WT.

SIZE
C

FSCM NO
21649

DRAWING NO.
HTL2-_____

REV.
G

THIRD ANGLE
PROJECTION

Scale 1:1

Sheet 4 OF 4

Компания «Океан Электроники» предлагает заключение долгосрочных отношений при поставках импортных электронных компонентов на взаимовыгодных условиях!

Наши преимущества:

- Поставка оригинальных импортных электронных компонентов напрямую с производств Америки, Европы и Азии, а так же с крупнейших складов мира;
- Широкая линейка поставок активных и пассивных импортных электронных компонентов (более 30 млн. наименований);
- Поставка сложных, дефицитных, либо снятых с производства позиций;
- Оперативные сроки поставки под заказ (от 5 рабочих дней);
- Экспресс доставка в любую точку России;
- Помощь Конструкторского Отдела и консультации квалифицированных инженеров;
- Техническая поддержка проекта, помощь в подборе аналогов, поставка прототипов;
- Поставка электронных компонентов под контролем ВП;
- Система менеджмента качества сертифицирована по Международному стандарту ISO 9001;
- При необходимости вся продукция военного и аэрокосмического назначения проходит испытания и сертификацию в лаборатории (по согласованию с заказчиком);
- Поставка специализированных компонентов военного и аэрокосмического уровня качества (Xilinx, Altera, Analog Devices, Intersil, Interpoint, Microsemi, Actel, Aeroflex, Peregrine, VPT, Syfer, Eurofarad, Texas Instruments, MS Kennedy, Miteq, Cobham, E2V, MA-COM, Hittite, Mini-Circuits, General Dynamics и др.);

Компания «Океан Электроники» является официальным дистрибьютором и эксклюзивным представителем в России одного из крупнейших производителей разъемов военного и аэрокосмического назначения «JONHON», а так же официальным дистрибьютором и эксклюзивным представителем в России производителя высокотехнологичных и надежных решений для передачи СВЧ сигналов «FORSTAR».



JONHON

«JONHON» (основан в 1970 г.)

Разъемы специального, военного и аэрокосмического назначения:

(Применяются в военной, авиационной, аэрокосмической, морской, железнодорожной, горно- и нефтедобывающей отраслях промышленности)

«FORSTAR» (основан в 1998 г.)

ВЧ соединители, коаксиальные кабели,
кабельные сборки и микроволновые компоненты:

(Применяются в телекоммуникациях гражданского и специального назначения, в средствах связи, РЛС, а так же военной, авиационной и аэрокосмической отраслях промышленности).



Телефон: 8 (812) 309-75-97 (многоканальный)

Факс: 8 (812) 320-03-32

Электронная почта: ocean@oceanchips.ru

Web: <http://oceanchips.ru/>

Адрес: 198099, г. Санкт-Петербург, ул. Калинина, д. 2, корп. 4, лит. А