

**FAILURE TO READ AND FOLLOW ALL INSTRUCTIONS CAREFULLY BEFORE INSTALLING OR OPERATING THIS CONTROL COULD CAUSE PERSONAL INJURY AND/OR PROPERTY DAMAGE.**

**DESCRIPTION**

The 50T35-743 is an automatic gas interrupted ignition control that employs a microprocessor to continually monitor, analyze, and control the proper operation of the gas burner, inducer, and fan. Signals interpreted during continual surveillance of the thermostat and flame sensing element initiate automatic ignition of the burner, sensing of the flame, and system shut-off during normal operation. This control incorporates system fault analysis for quick gas flow shut-off, coupled with automatic ignition retry upon sensing a fault correction. It is designed as a replacement for the following controls:

Model	Replaces
White-Rodgers 50T35-730	Goodman B18099-06 Goodman B18099-13S
White-Rodgers 50T35-743	Goodman B18099-08 Goodman 1012-933D Goodman B18099-10 Goodman 41F-5 Goodman B18099-13

**PRECAUTIONS**

Installation should be done by a qualified heating and air conditioning contractor or licensed electrician.

If in doubt about whether your wiring is millivolt, line, or low voltage, have it inspected by a qualified heating and air conditioning contractor or licensed electrician.

Do not exceed the specification ratings.

All wiring must conform to local and national electrical codes and ordinances.

This control is a precision instrument, and should be handled carefully. Rough handling or distorting components could cause the control to malfunction.

Following installation or replacement, follow manufacturer's recommended installation/service instructions to ensure proper operation.

**CAUTION**

**Do not short out terminals on gas valve or primary control. Short or incorrect wiring may damage the thermostat.**

**! WARNING**



**Failure to comply with the following warnings could result in personal injury or property damage.**

**FIRE HAZARD**

- Do not exceed the specified voltage.
- Protect the control from direct contact with water (dripping, spraying, rain, etc.).
- If the control has been in direct contact with water, replace the control.
- Label all wires before disconnection when servicing controls. Wiring errors can cause improper and dangerous operation.
- Route and secure wiring away from flame.

**SHOCK HAZARD**

- Disconnect electric power before servicing .
- Ensure proper earth grounding of appliance.
- Ensure proper connection of line neutral and line hot wires.

**EXPLOSION HAZARD**

- Shut off main gas to appliance until installation is complete.

# SPECIFICATIONS

## ELECTRICAL RATINGS [ @ 77°F (25°C)]:

- Input Voltage:** 25 VAC 60 Hz
- Max. Input Current @ 25 VAC:** 0.5 amp + MV Load
- Relay Load Ratings:
  - Valve Relay: 1.5 amp @ 24 VAC 60 Hz 0.6 pf
  - Ignitor Relay: 5.0 amp @ 120 VAC 60 Hz (resistive)
  - Circulator Relay: 11 FLA–26.0 LRA @ 120 VAC

### Flame Current Requirements:

- Minimum current to insure flame detection: 1 µA DC\*
- Maximum current for non-detection: 0.1 µA DC\*
- Maximum allowable leakage resistance: 100 M ohms

\*Measured with a DC microammeter in the flame probe lead

## OPERATING TEMPERATURE RANGE:

-40° to 175°F (-40° to 80°C)

## HUMIDITY RANGE:

5% to 93% relative humidity (non-condensing)

## MOUNTING:

Surface mount multipoise

## Timing Specs:

Flame Establishing Time:	<b>maximum</b> 0.8 sec
Flame Failure Response Time:	2.0 sec

**Gases Approved:** Natural, Manufactured, Mixed, Liquefied Petroleum, and LP Gas Air Mixtures are all approved for use.

<b>Timing Specifications</b> (All times are in seconds, unless noted otherwise)		
<b>Timing Specification</b>	<b>Description</b>	<b>50T35-743</b>
Pre-Purge	Initial delay between thermostat contact closure and trial for ignition.	15
Initial Ignitor Warm-Up	Duration of ignitor warm-up time on the first 64 attempts.	15
Retry Ignitor Warm-Up	Duration of ignitor warm-up time if the control retries.	20
Ignition Activation Period	The period of time between energizing the main gas valve and deactivation of the ignition means prior to the lockout time.	5
Trial for Ignition	Period during which the valve and ignition source is activated, attempting to ignite gas at the burner.	7
Retries	Additional ignition attempts if the original ignition attempt is unsuccessful.	2 times
Valve Sequence Period	Valve sequence period is the cumulative total amount of time that the gas valve is energized before entering lockout.	12
Inter-Purge	Period between trials for ignition when both the gas valve and ignition source are deactivated to allow unburned gas to escape before the next trial	30
Post-Purge	After all ignition cycles are complete, the control will enter post-purge. The combustion fan will remain on to allow unburned gas to escape. After post-purge is complete, the combustion fan will turn off.	25/29 (90+ option)
Lockout Time	The period of time between initiation of gas flow and the action to shut off the gas flow in the event of failure to establish proof of the supervised ignition source or the supervised main burner flame. Reinitiating the lighting sequence requires a manual operation if ignition is required before Auto reset.	300
Heat Delay to Fan On	Timing to allow the heat to build up in the plenum before turning on the fan.	30
Heat Delay to Fan Off	Timing to allow the fan to run after the call for heat ends. This allows residual heat to be removed from the heat exchanger and distributed to the conditioned space.	90/120/150
Cool Delay to Fan On	Timing to allow the cooling coil to cool off before turning on the fan.	5
Cool Delay to Fan Off	Timing to allow the fan to run after the call for cool ends. This allows residual cooling capacity to be removed from the cooling coils and distributed to the conditioned space.	60
Auto Reset	If shutoff occurs, the control delays for a specific recycle delay period before beginning another trial for ignition (models with retries only).	60 minutes

\*These times will vary depending on option switch position. See INSTALLATION section for further information.



### FIRE HAZARD

- Do not exceed the specified voltage.
- Protect the control from direct contact with water (dripping, spraying, rain, etc.).
- Label all wires before disconnection when servicing controls. Wiring errors can cause improper and dangerous operation.
- Route and secure wiring away from flame.

### SHOCK HAZARD

- Disconnect electric power before servicing .
- Ensure proper earth grounding of appliance.
- Ensure proper connection of line neutral and line hot wires.

### EXPLOSION HAZARD

- Shut off main gas to appliance until installation is complete.

**Do not short out terminals on gas valve or primary control. Short or incorrect wiring may damage the thermostat.**



## MOUNTING AND WIRING

All wiring should be installed according to local and national electrical codes and ordinances.

The control must be secured to an area that will experience a minimum of vibration and remain below the maximum ambient temperature rating of 175°F. The control is approved for minimum ambient temperatures of -40°F.

Any orientation is acceptable.

Refer to the wiring diagram and wiring table when connecting the 50T35 control to other components of the system.

UL approved, 105°C rated 18 gauge, stranded, 2/64" thick insulation wire is recommended for all low voltage safety circuit connections.

UL approved 105°C rated 16 gauge min., stranded, 4/64" thick insulation wire is recommended for all line voltage connections.

Follow the appliance manufacturer's recommended installation or service instructions.

The 50T35 has only one serviceable part—an automotive type fuse, which protects the low voltage transformer from damage if its output is short-circuited. If the fuse has opened up, remove whatever caused the short circuit and replace the fuse with only a 3 Amp automotive type fuse. If the fuse is not the cause of the control's problem, replace the entire 50T35 control. There are no other user serviceable parts.

Remove both access panels.

For GMP & GMPV series units, cut the white jumper wire between pins 4 & 7 of the 9-pin connector.

For GMPN & GMN series units, DO NOT cut the white jumper wire.

Remove the edgcard connector and other wires from the existing module. Discard the thermostat wires removed from the board (R, W & G).

Remove the existing HSI module. Care should be exercised as not to damage the nylon standoffs.

Install the 50T35-743 module.

Reconnect the edgcard connector making sure of good contact.

Push the 9-pin connector into the HSI module. It can go in only one way. DO NOT force.

Reconnect the supplied thermostat wires.

Remove the red wire from the 24 volt side of the secondary side of the transformer and discard.

Remove the blue ground wire from the transformer. DO NOT discard.

Remove the blue wire from the transformer and discard.

Connect the red wire from the 9 pin connector on to "24 volt" of the secondary side of the transformer.

Connect the blue wire from the 9-pin connector to "Common" terminal of the secondary side of the transformer. This wire has a piggy back terminal.

Connect the blue ground wire, which was previously removed, also to the "Common" terminal of the transformer.

Replace the access panels.

Restore gas and electrical power to the furnace.

Verify the sequence of operation as noted in the furnace manufacturer's Installation & Operating Instructions.

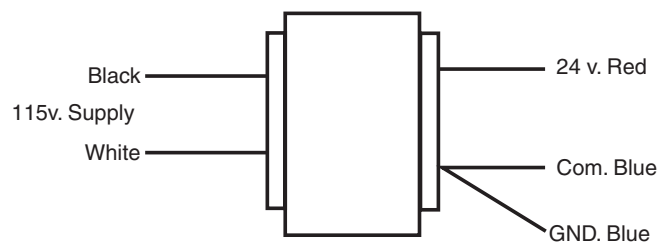

TRANSFORMER

# INSTALLATION

## SELECTING THE BLOWER OFF DELAY

In the heating mode, the blower off delay can be selected to obtain a 90, 120 or 150 seconds period. This can be accomplished by changing the position of the plastic jumper located on the ignition control. See the drawing below for the location of this jumper.

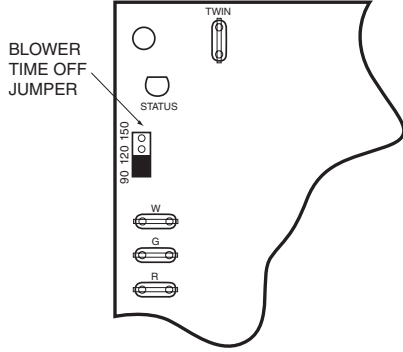

The control is factory set to give a (150) second blower off delay. See drawing below for the jumper position for all available settings:

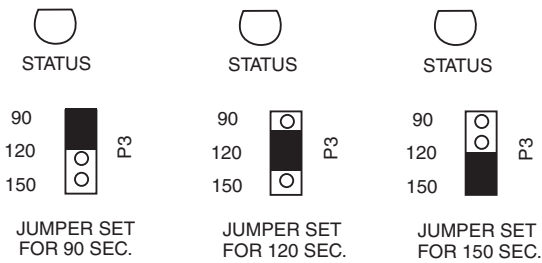

### Notes:

- If the jumper is removed, the control will default to a (150) second blower off delay in the heating mode.
- The blower on time in the heating mode is (30) seconds and is non-adjustable.
- The blower on time in the cooling mode is (7) seconds and is non-adjustable.
- The blower off delay in the cooling mode is (60) seconds and is non-adjustable.
- Caution is to be exercised not to bend the metal pins when changing the time delay from the factory setting.

## DIAGNOSTIC FEATURES

The 50T35-743 control continuously monitors its own operation and the operation of the system. If a failure occurs, the LED will indicate a failure code as shown below. **If the failure is internal to the control, the light will stay off. In this case, the entire control should be replaced, as the control is not field-repairable.**

If the sensed failure is in the system (external to the control), the LED will flash in the following flash-pause sequences to indicate failure status (each flash will last approximately 0.25 seconds, and each pause will last approximately 2 seconds).

LED	Condition	Monitored During	Action
Solid On	Normal	All Times	None required
1 Flash	Ignition retries exceeded	Heating Demand	Gas Valve "Off" Circulator "Delay Off" Inducer "Off"
2 Flashes	PSW Stuck Closed	Heating Demand Only	All Outputs "Off" except circ cool speed in response to a call for fan/cool
3 Flashes	PSW Stuck Open	Heating Demand Only	All Outputs "Off" except circ cool speed in response to a call for fan/cool
4 Flashes	Limit Switch Open	Heating Demand Only	Gas Valve "Off" Circulator "On" Inducer "On"
5 Flashes	Improper Flame	All Times	Gas Valve "Off" Circulator "On" Inducer "On"
Rapid Flashing	Improper Polarity	Power-up	Gas Valve "Off" Circulator "Off" Inducer "Off"
	Twinning Fault	All other times	Gas Valve "Off" Circulator "Off" Inducer "Off"
Off	Internal error detected	All Times	Gas Valve "Off" Circulator "Off" Inducer "Off"

# TYPICAL SYSTEM WIRING DIAGRAM

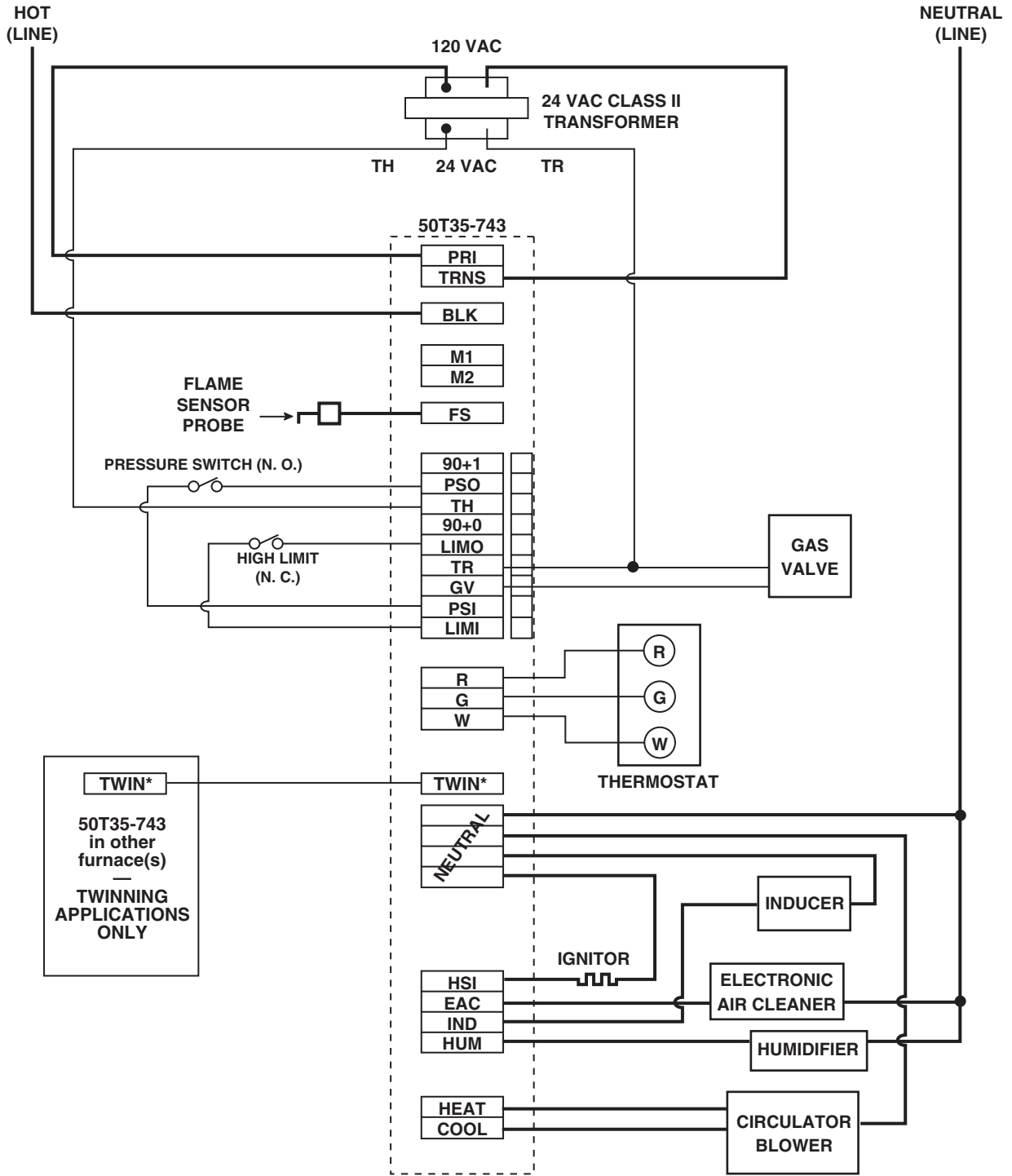

TWIN\*  
50T35-743  
in other  
furnace(s)  
—  
TWINNING  
APPLICATIONS  
ONLY

LEGEND	
	Low Voltage (24 VAC)
	Line Voltage (120 VAC)
	N. C. = Normally closed switch
	N. O. = Normally open switch

\* The twinning feature is available only on models with six screw terminals; one of these terminals will be designated "TWIN". All 50T35-743 controls used in twinning applications must have the "TWIN" terminal.

**TYPICAL SYSTEM WIRING TABLE**

<b>50T35 TERMINAL</b>	<b>TERMINAL TYPE</b>	<b>SYSTEM COMPONENT CONNECTION</b>
W G R	3/16" spade terminals	low voltage thermostat W terminal (or equivalent) low voltage thermostat G terminal (or equivalent) low voltage thermostat R terminal (or equivalent)
TWIN*	3/16" spade terminals	one wire twinning terminal
90+1 PSO TH 90+0 LIMO TR GV PSI LIMO	9-pin connector & harness or edge connector	option jumper for GMP and GMPV Series Units pressure switch OUTPUT 24 VAC transformer (low voltage HIGH side) option jumper for GMP and GMPV Series Units high limit OUTPUT 24 VAC transformer (low voltage COMMON side) gas valve pressure switch INPUT high limit INPUT
IND	1/4" spade terminal	inducer HOT side
HSI	1/4" spade terminal	ignitor HOT side
EAC	1/4" spade terminal	electronic air cleaner HOT side
HUM	1/4" spade terminal	humidifier HOT side
COOL	1/4" spade terminal	circulator blower COOL SPEED terminal
HEAT	1/4" spade terminal	circulator blower HEAT SPEED terminal
NEUTRAL (4 terminals)	1/4" spade terminals	input voltage (120 VAC) NEUTRAL side and NEUTRAL line connections
FS	1/4" spade terminal	flame sensor probe†
M1	1/4" spade terminal	park
M2	1/4" spade terminal	park
PRI	1/4" spade terminal	24 VAC transformer line voltage HOT side
TRNS	1/4" spade terminal	24 VAC transformer line voltage NEUTRAL side
BLK	1/4" spade terminal	input voltage (120 VAC) HOT side

\* All 50T35-743 controls used in twinning applications must have the "TWIN" terminal.

† Maximum recommended flame probe wire length is 36 inches.

---

# NOTES

---

**TECHNICAL SUPPORT: 1-888-725-9797**

White-Rodgers is a business  
of Emerson Electric Co.

The Emerson logo is a  
trademark and service mark  
of Emerson Electric Co.

**White-Rodgers™**

[www.white-rodgers.com](http://www.white-rodgers.com)  
[www.emersonclimate.com](http://www.emersonclimate.com)

  
**EMERSON™**  
Climate Technologies



Компания «Океан Электроники» предлагает заключение долгосрочных отношений при поставках импортных электронных компонентов на взаимовыгодных условиях!

Наши преимущества:

- Поставка оригинальных импортных электронных компонентов напрямую с производств Америки, Европы и Азии, а так же с крупнейших складов мира;
- Широкая линейка поставок активных и пассивных импортных электронных компонентов (более 30 млн. наименований);
- Поставка сложных, дефицитных, либо снятых с производства позиций;
- Оперативные сроки поставки под заказ (от 5 рабочих дней);
- Экспресс доставка в любую точку России;
- Помощь Конструкторского Отдела и консультации квалифицированных инженеров;
- Техническая поддержка проекта, помощь в подборе аналогов, поставка прототипов;
- Поставка электронных компонентов под контролем ВП;
- Система менеджмента качества сертифицирована по Международному стандарту ISO 9001;
- При необходимости вся продукция военного и аэрокосмического назначения проходит испытания и сертификацию в лаборатории (по согласованию с заказчиком);
- Поставка специализированных компонентов военного и аэрокосмического уровня качества (Xilinx, Altera, Analog Devices, Intersil, Interpoint, Microsemi, Actel, Aeroflex, Peregrine, VPT, Syfer, Eurofarad, Texas Instruments, MS Kennedy, Miteq, Cobham, E2V, MA-COM, Hittite, Mini-Circuits, General Dynamics и др.);

Компания «Океан Электроники» является официальным дистрибьютором и эксклюзивным представителем в России одного из крупнейших производителей разъемов военного и аэрокосмического назначения «JONHON», а так же официальным дистрибьютором и эксклюзивным представителем в России производителя высокотехнологичных и надежных решений для передачи СВЧ сигналов «FORSTAR».



## JONHON

«JONHON» (основан в 1970 г.)

Разъемы специального, военного и аэрокосмического назначения:

(Применяются в военной, авиационной, аэрокосмической, морской, железнодорожной, горно- и нефтедобывающей отраслях промышленности)

«FORSTAR» (основан в 1998 г.)

ВЧ соединители, коаксиальные кабели,  
кабельные сборки и микроволновые компоненты:

(Применяются в телекоммуникациях гражданского и специального назначения, в средствах связи, РЛС, а так же военной, авиационной и аэрокосмической отраслях промышленности).



Телефон: 8 (812) 309-75-97 (многоканальный)

Факс: 8 (812) 320-03-32

Электронная почта: [ocean@oceanchips.ru](mailto:ocean@oceanchips.ru)

Web: <http://oceanchips.ru/>

Адрес: 198099, г. Санкт-Петербург, ул. Калинина, д. 2, корп. 4, лит. А