

# NCV7351

## High Speed CAN Transceiver

The NCV7351 CAN transceiver is the interface between a controller area network (CAN) protocol controller and the physical bus and may be used in both 12 V and 24 V systems. The transceiver provides differential transmit capability to the bus and differential receive capability to the CAN controller.

The NCV7351 is an addition to the CAN high-speed transceiver family complementing NCV734x CAN stand-alone transceivers and previous generations such as AMIS42665, AMIS3066x, etc. Due to the wide common-mode voltage range of the receiver inputs and other design features, the NCV7351 is able to reach outstanding levels of electromagnetic susceptibility (EMS). Similarly, extremely low electromagnetic emission (EME) is achieved by the excellent matching of the output signals.

### KEY FEATURES

#### General

- Compatible with the ISO 11898-2 Standard
- High Speed (up to 1 Mbps)
- V<sub>IO</sub> Pin on NCV7351D13 Version Allowing Direct Interfacing with 3 V to 5 V Microcontrollers
- EN Pin on NCV7351D1E Version Allowing Switching the Transceiver to a Very Low Current OFF Mode
- Excellent Electromagnetic Susceptibility (EMS) Level Over Full Frequency Range. Very Low Electromagnetic Emissions (EME) Low EME also Without Common Mode (CM) Choke
- Bus Pins Protected Against >15 kV System ESD Pulses
- Transmit Data (TxD) Dominant Time-out Function
- Under all Supply Conditions the Chip Behaves Predictably. No Disturbance of the Bus Lines with an Unpowered Node
- Bus Pins Short Circuit Proof to Supply Voltage and Ground
- Bus Pins Protected Against Transients in an Automotive Environment
- Thermal Protection
- These are Pb-Free Devices

#### Quality

- NCV Prefix for Automotive and Other Applications Requiring Unique Site and Control Change Requirements; AEC-Q100 Qualified and PPAP Capable

#### Typical Applications

- Automotive
- Industrial Networks



ON Semiconductor®

<http://onsemi.com>

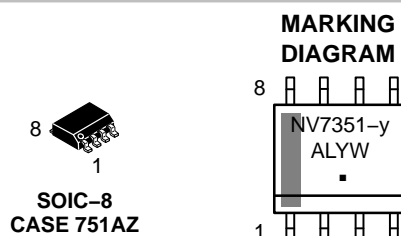

NV7351- = Specific Device Code  
y = 3, 0, or E  
A = Assembly Location  
L = Wafer Lot  
Y = Year  
W = Work Week  
▪ = Pb-Free Package

### PIN ASSIGNMENT

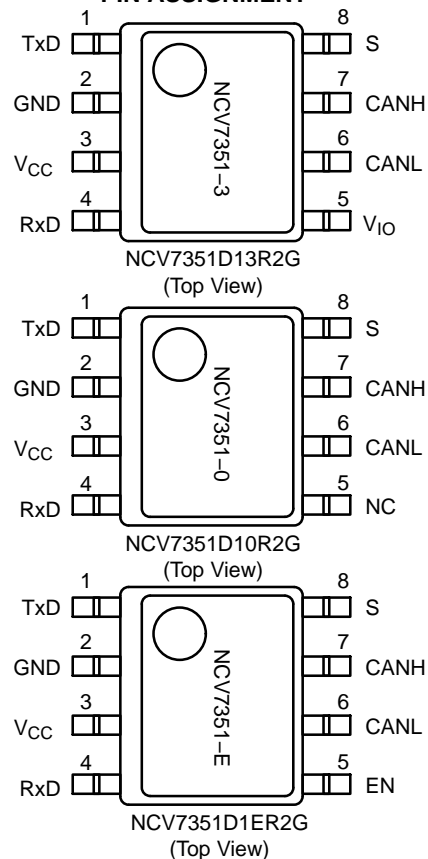

### ORDERING INFORMATION

See detailed ordering and shipping information in the package dimensions section on page 10 of this data sheet.

# NCV7351

**Table 1. KEY TECHNICAL CHARACTERISTICS AND OPERATING RANGES**

| Symbol                 | Parameter  | Conditions   | Min      | Max       | Unit |
|------------------------|--|--|----------|-----------|------|
| $V_{CC}$               | Power supply voltage                                       |  | 4.5      | 5.5       | V    |
| $V_{UV}$               | Undervoltage detection voltage on pin $V_{CC}$             |  | 3.5      | 4.5       | V    |
| $V_{CANH}$             | DC voltage at pin CANH                                     | $0 < V_{CC} < 5.5$ V; no time limit                            | -50      | +50       | V    |
| $V_{CANL}$             | DC voltage at pin CANL                                     | $0 < V_{CC} < 5.5$ V; no time limit                            | -50      | +50       | V    |
| $V_{CANH,L}$           | DC voltage between CANH and CANL pin                       | $0 < V_{CC} < 5.5$ V   | -50      | +50       | V    |
| $V_{CANH,Lmax}$        | DC voltage at pin CANH and CANL during load dump condition | $0 < V_{CC} < 5.5$ V, less than one second                     | -        | +58       | V    |
| $V_{ESD}$              | Electrostatic discharge voltage                            | IEC 61000-4-2 at pins CANH and CANL                            | -15      | 15        | kV   |
| $V_{O(dif)(bus\_dom)}$ | Differential bus output voltage in dominant state          | $45 \Omega < R_{LT} < 65 \Omega$                               | 1.5      | 3         | V    |
| CM-range               | Input common-mode range for comparator                     | Guaranteed differential receiver threshold and leakage current | -30      | +35       | V    |
| $I_{CC}$               | Supply current   | Dominant; $V_{TxD} = 0$ V<br>Recessive; $V_{TxD} = V_{CC}$     | -<br>2.5 | 72<br>7.5 | mA   |
| $I_{CCS}$              | Supply current in silent mode                              |  | 1.4      | 3.5       | mA   |
| $t_{pd}$               | Propagation delay TxD to RxD                               | See Figure 5   | 90       | 245       | ns   |
| $T_J$                  | Junction temperature                                       |  | -40      | 150       | °C   |

# NCV7351

## BLOCK DIAGRAM

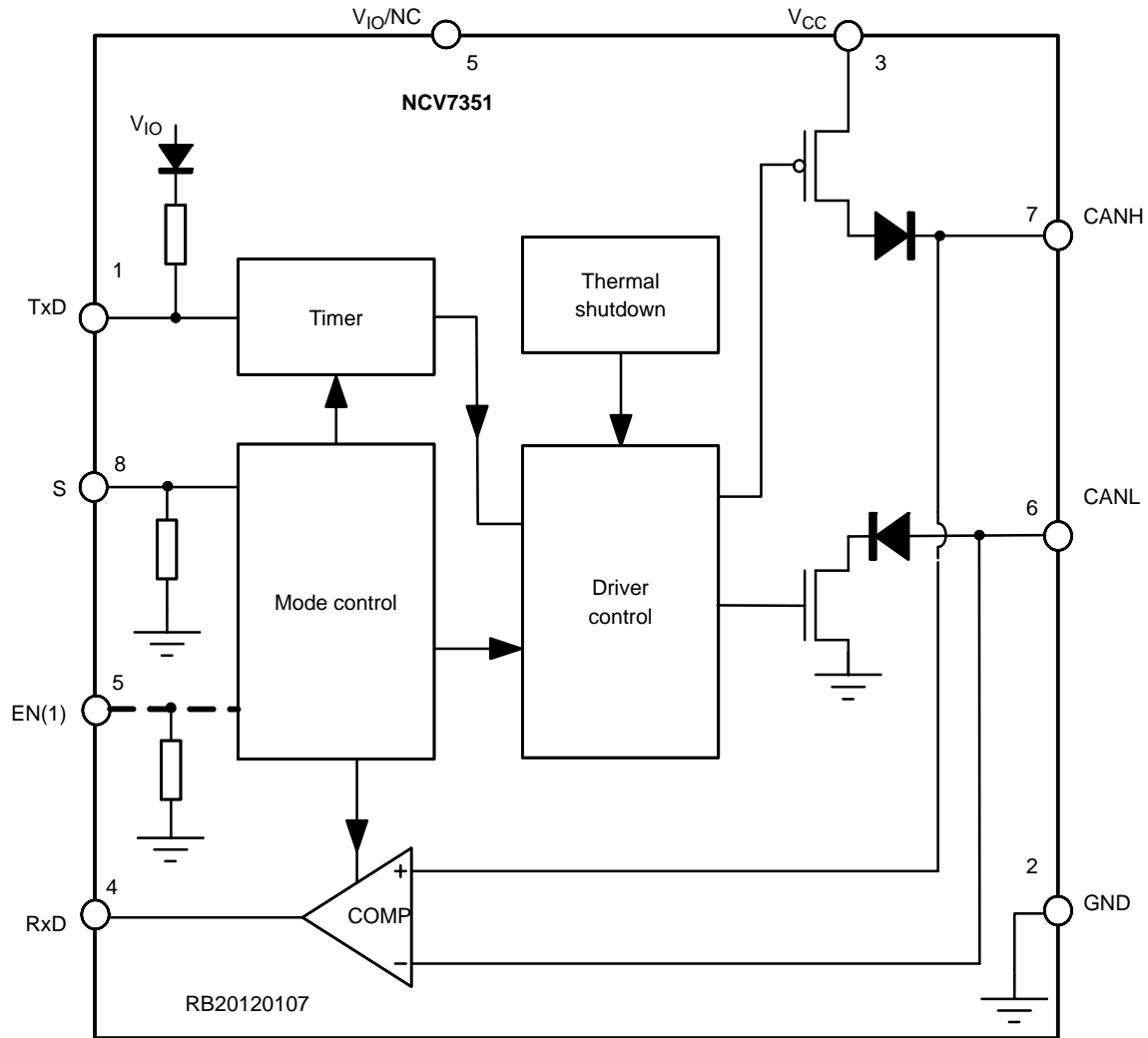

- (1) Only present in the NCV7351D1ER2G  
 (2) Connected to  $V_{CC}$  on versions without  $V_{IO}$  pin

**Figure 1. Block Diagram of NCV7351**

**Table 2. NCV7351: PIN FUNCTION DESCRIPTION**

| Pin Number | Pin Name | Pin Type                          | Pin Function  |
|------------|----------|-----------------------------------|---|
| 1          | TxD      | digital input, internal pull-up   | Transmit data input; low input → dominant driver                  |
| 2          | GND      | ground                            | Ground  |
| 3          | $V_{CC}$ | supply                            | Supply voltage  |
| 4          | RxD      | digital output                    | Receive data output; dominant bus → low output                    |
| 5          | NC       | not connected                     | Not connected, NCV7351-0 version only                             |
|            | $V_{IO}$ | supply                            | Supply voltage for digital inputs/outputs, NCV7351-3 Version only |
|            | EN       | digital input, internal pull-down | Enable control input, NCV7351-E version only                      |
| 6          | CANL     | high voltage input/output         | Low-level CAN bus line (low in dominant mode)                     |
| 7          | CANH     | high voltage input/output         | High-level CAN bus line (high in dominant mode)                   |
| 8          | S        | digital input, internal pull-down | Silent mode control input   |

# NCV7351

## APPLICATION INFORMATION

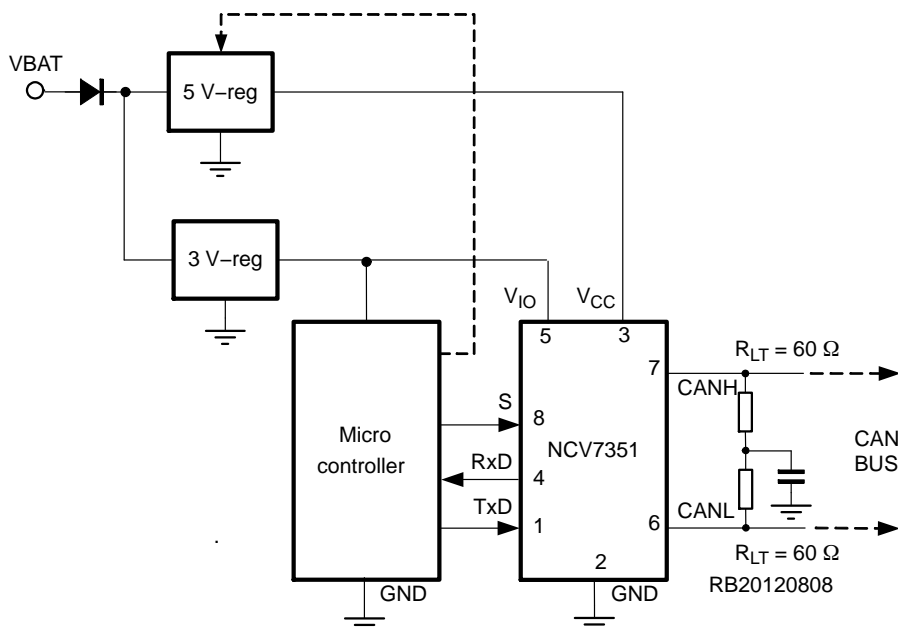

Figure 2. NCV7351-3 Application Diagram

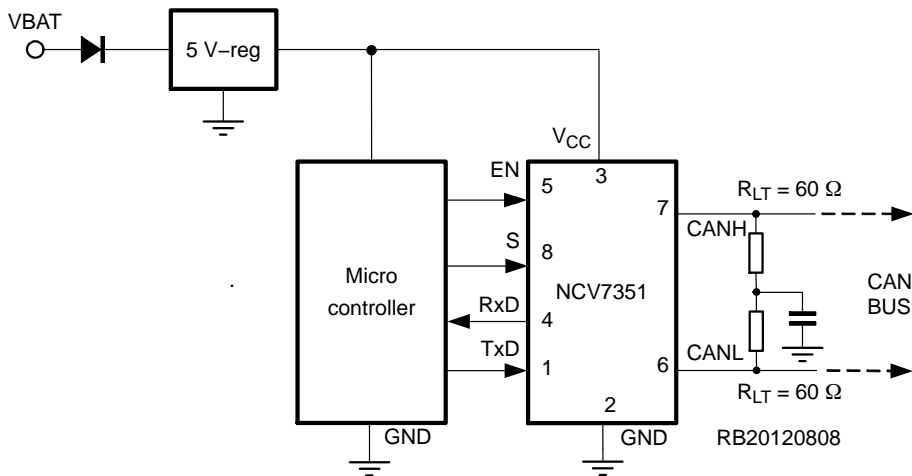

Figure 3. NCV7351-E Application diagram

## FUNCTIONAL DESCRIPTION

**NCV7351** has three versions which differ from each other only by function of pin 5. (See also Table 2)

**NCV7351-3:** Pin 5 is  $V_{IO}$  pin, which is supply pin for transceiver digital inputs/output (supplying pins TxD, RxD, S, EN). The  $V_{IO}$  pin should be connected to microcontroller supply pin. By using  $V_{IO}$  supply pin shared with microcontroller the I/O levels between microcontroller and transceiver are properly adjusted. This allows in applications with microcontroller supply down to 3 V to easy communicate with the transceiver. (See Figure 2)

**NCV7351-0:** Pin 5 is not connected. This version is full replacement of the previous generation CAN transceiver AMIS30660.

**NCV7351-E:** Pin 5 is digital enable pin which allows transceiver to be switched off with very low supply current.

### OPERATING MODES

The NCV7351 modes of operation are provided as illustrated in Table 3. These modes are selectable through pin S and also EN in case of NCV7351-E.

**Table 3. OPERATING MODES**

| Mode         | Pin S | Pin EN (Note 1) | Pin TxD | CANH,L Pins       | RxD      |
|--------------|-------|-----------------|---------|-------------------|----------|
| Normal       | 0     | 1               | 0       | Dominant          | 0        |
|              | 0     | 1               | 1       | Recessive         | 1        |
| Silent       | 1     | 1               | X       | Recessive         | 1        |
|              | 1     | 1               | X       | Dominant (Note 3) | 0        |
| Off (Note 1) | X     | 0               | X       | floating          | floating |

1. Only applicable to NCV7351-E
2. 'X' = don't care
3. CAN bus driven to dominant by another transceiver on the bus

#### Normal Mode

In the normal mode, the transceiver is able to communicate via the bus lines. The signals are transmitted and received to the CAN controller via the pins TxD and RxD. The slopes on the bus lines outputs are optimized to give low EME.

#### Silent Mode

In the silent mode, the transmitter is disabled. The bus pins are in recessive state independent of TxD input. Transceiver listens to the bus and provides data to controller, but controller is prevented from sending any data to the bus.

#### Off Mode

In Off mode, complete transceiver is disabled and consumes very low current. The CAN pins are floating not loading the CAN bus.

#### Over-temperature Detection

A thermal protection circuit protects the IC from damage by switching off the transmitter if the junction temperature exceeds a value of approximately 180°C. Because the transmitter dissipates most of the power, the power dissipation and temperature of the IC is reduced. All other IC functions continue to operate. The transmitter off-state resets when the temperature decreases below the shutdown threshold and pin TxD goes high. The thermal protection

circuit is particularly needed in case of the bus line short circuits.

#### TxD Dominant Time-out Function

A TxD dominant time-out timer circuit prevents the bus lines being driven to a permanent dominant state (blocking all network communication) if pin TxD is forced permanently low by a hardware and/or software application failure. The timer is triggered by a negative edge on pin TxD. If the duration of the low-level on pin TxD exceeds the internal timer value  $t_{dom}$ , the transmitter is disabled, driving the bus into a recessive state. The timer is reset by a positive edge on pin TxD. This TxD dominant time-out time ( $t_{dom(TxD)}$ ) defines the minimum possible bit rate to 12 kbps.

#### Fail Safe Features

A current-limiting circuit protects the transmitter output stage from damage caused by accidental short circuit to either positive or negative supply voltage, although power dissipation increases during this fault condition.

The pins CANH and CANL are protected from automotive electrical transients (according to ISO 7637; Figure 4). Internally, pin TxD is pulled high, pin EN and S low should the input become disconnected. Pins TxD, S, EN and RxD will be floating, preventing reverse supply should the  $V_{CC}$  supply be removed.

# NCV7351

**Definitions:** All voltages are referenced to GND (pin 2). Positive currents flow into the IC. Sinking current means the current is flowing into the pin; sourcing current means the current is flowing out of the pin.

**Table 4. ABSOLUTE MAXIMUM RATINGS**

| Symbol       | Parameter   | Conditions                          | Min  | Max  | Unit |
|--------------|---|-------------------------------------|------|------|------|
| $V_{sup}$    | Supply voltage $V_{CC}$   |                                     | -0.3 | +6   | V    |
| $V_{CANH}$   | DC voltage at pin CANH  | $0 < V_{CC} < 5.5$ V; no time limit | -50  | +50  | V    |
| $V_{CANL}$   | DC voltage at pin CANL  | $0 < V_{CC} < 5.5$ V; no time limit | -50  | +50  | V    |
| $V_{IOs}$    | DC voltage at pin TxD, RxD, S, EN, $V_{IO}$                                   | Notes 4 and 5                       | -0.3 | 6    | V    |
| $V_{esd}$    | Electrostatic discharge voltage at all pins according to EIA-JESD22           | Note 6                              | -6   | 6    | kV   |
|              | Electrostatic discharge voltage at CANH,CANL, pins according to EIA-JESD22    | Note 6                              | -8   | 8    | kV   |
|              | Electrostatic discharge voltage at CANH, CANL pins According to IEC 61000-4-2 | Note 7                              | -15  | 15   | kV   |
|              | Standardized charged device model ESD pulses according to ESD-STM5.3.1-1999   |                                     | 750  | 750  | V    |
| $V_{schaff}$ | Transient voltage at CANH, CANL pins, See Figure 4                            | Note 8                              | -150 | 100  | V    |
| Latch-up     | Static latch-up at all pins   | Note 9                              |      | 150  | mA   |
| $T_{stg}$    | Storage temperature   |                                     | -55  | +150 | °C   |
| $T_J$        | Maximum junction temperature  |                                     | -40  | +170 | °C   |

Stresses exceeding Maximum Ratings may damage the device. Maximum Ratings are stress ratings only. Functional operation above the Recommended Operating Conditions is not implied. Extended exposure to stresses above the Recommended Operating Conditions may affect device reliability.

4. EN pin Only available on NCV7351-E version
5.  $V_{IO}$  pin Only available on NCV7351-3 version
6. Standardized human body model electrostatic discharge (ESD) pulses in accordance to EIA-JESD22. Equivalent to discharging a 100 pF capacitor through a 1.5 k $\Omega$  resistor.
7. System human body model electrostatic discharge (ESD) pulses. Equivalent to discharging a 150 pF capacitor through a 330  $\Omega$  resistor referenced to GND. Verified by external test house
8. Pulses 1, 2a,3a and 3b according to ISO 7637 part 3. Results were verified by external test house.
9. Static latch-up immunity: Static latch-up protection level when tested according to EIA/JESD78.

**Table 5. THERMAL CHARACTERISTICS**

| Symbol             | Parameter  | Conditions | Value | Unit |
|--------------------|--|------------|-------|------|
| $R_{\theta JA\_1}$ | Thermal Resistance Junction-to-Air, 1S0P PCB (Note 10) | Free air   | 125   | K/W  |
| $R_{\theta JA\_2}$ | Thermal Resistance Junction-to-Air, 2S2P PCB (Note 11) | Free air   | 75    | K/W  |

10. Test board according to EIA/JEDEC Standard JESD51-3, signal layer with 10% trace coverage.
11. Test board according to EIA/JEDEC Standard JESD51-7, signal layers with 10% trace coverage.

# NCV7351

## ELECTRICAL CHARACTERISTICS

$V_{CC} = 4.5\text{ V to }5.5\text{ V}$ ;  $V_{IO} = 2.8\text{ V to }5.5\text{ V}$ ;  $T_J = -40^\circ\text{C to }+150^\circ\text{C}$ ;  $R_{LT} = 60\ \Omega$  unless specified otherwise.  
On chip versions without  $V_{IO}$  pin reference voltage for all digital inputs and outputs is  $V_{CC}$  instead of  $V_{IO}$ .

**Table 6. CHARACTERISTICS**

| Symbol  | Parameter  | Conditions  | Min                 | Typ        | Max                  | Unit          |
|---|--|---|---------------------|------------|----------------------|---------------|
| <b>SUPPLY (Pin <math>V_{CC}</math>)</b>                           |  |   |                     |            |                      |               |
| $I_{CC}$  | Supply current in normal mode                                      | Dominant; $V_{TXD} = 0\text{ V}$<br>Recessive; $V_{TXD} = V_{IO}$ | –<br>2.5            | 50<br>4.6  | 72<br>7.5            | mA            |
| $I_{CCS}$   | Supply current in silent mode                                      |   | 1.4                 | 2.3        | 3.5                  | mA            |
| $I_{CCOFF}$   | Supply current in OFF mode on NCV7351–E version only               |   | –                   | 7          | 18                   | $\mu\text{A}$ |
| $I_{CCOFF}$   | Supply current in OFF mode NCV7351–E version only                  | $T_J \leq 100^\circ\text{C}$ ,<br>Note 13                         | –                   | 7          | 10                   | $\mu\text{A}$ |
| $V_{UVDVCC}$  | Undervoltage detection voltage on $V_{CC}$ pin                     |   | 3.5                 | 4          | 4.5                  | V             |
| <b>SUPPLY (Pin <math>V_{IO}</math>) on NCV7351–3 Version Only</b> |  |   |                     |            |                      |               |
| $V_{iorange}$   | Supply voltage range on pin $V_{IO}$                               |   | 2.8                 | –          | 5.5                  | V             |
| $I_{IO}$  | Supply current on pin $V_{IO}$ normal mode                         | Dominant; $V_{TXD} = 0\text{ V}$<br>Recessive; $V_{TXD} = V_{IO}$ | 100<br>50           | 240<br>125 | 500<br>265           | $\mu\text{A}$ |
| $I_{IOS}$   | Supply current on pin $V_{IO}$ silent mode                         | Bus is recessive;<br>$V_{TXD} = V_{IO}$                           | –                   | 2          | 16                   | $\mu\text{A}$ |
| $V_{UVDVIO}$  | Undervoltage detection voltage on $V_{IO}$ pin                     |   | 2.1                 | 2.4        | 2.7                  | V             |
| <b>TRANSMITTER DATA INPUT (Pin TxD)</b>                           |  |   |                     |            |                      |               |
| $V_{IH}$  | High–level input voltage, on NCV7351–3 version only                | Output recessive  | $0.7 \times V_{IO}$ | –          | $V_{IO} + 0.3$       | V             |
| $V_{IH}$  | High–level input voltage, on NCV7351–1 and NCV7351–E versions only | Output recessive  | 2.7                 | –          | $V_{CC} + 0.3$       | V             |
| $V_{IL}$  | Low–level input voltage  | Output dominant   | –0.3                | –          | $+0.3 \times V_{IO}$ | V             |
| $R_{TXD}$   | TxD pin pull up  |   | 22                  | 30         | 50                   | k $\Omega$    |
| $C_i$   | Input capacitance  | Note 13   | –                   | 5          | 10                   | pF            |
| <b>TRANSMITTER MODE SELECT (Pin S and EN)</b>                     |  |   |                     |            |                      |               |
| $V_{IH}$  | High–level input voltage, on NCV7351–3 version only                | Silent mode   | $0.7 \times V_{IO}$ | –          | $V_{IO} + 0.3$       | V             |
| $V_{IH}$  | High–level input voltage on NCV7351–1 and NCV7351–E versions only  | Silent or enable mode   | 2.7                 | –          | $V_{CC} + 0.3$       | V             |
| $V_{IL}$  | Low–level input voltage  | Normal mode   | –0.3                | –          | $0.3 \times V_{IO}$  | V             |
| $R_{S,EN}$  | S and EN pin pull down   | Note 12   | 0.55                | 1.1        | 1.5                  | M $\Omega$    |
| $C_i$   | Input capacitance  | Note 13   | –                   | 5          | 10                   | pF            |
| <b>RECEIVER DATA OUTPUT (Pin RxD)</b>                             |  |   |                     |            |                      |               |
| $I_{OH}$  | High–level output current  | Normal mode<br>$V_{RXD} = V_{IO} - 0.4\text{ V}$                  | –1                  | –0.4       | –0.1                 | mA            |
| $I_{OL}$  | Low–level output current   | $V_{RXD} = 0.4\text{ V}$  | 1.5                 | 6          | 11                   | mA            |
| <b>BUS LINES (Pins CANH and CANL)</b>                             |  |   |                     |            |                      |               |

12. EN pin Only available on NCV7351–E version

13. Not tested in production. Guaranteed by design and prototype evaluation.

Table 6. CHARACTERISTICS

| Symbol                                | Parameter   | Conditions   | Min  | Typ  | Max  | Unit          |
|---------------------------------------|---|--|------|------|------|---------------|
| <b>BUS LINES (Pins CANH and CANL)</b> |   |  |      |      |      |               |
| $V_{o(reces)}$ (norm)                 | Recessive bus voltage on pins CANH and CANL                         | $V_{TxD} = V_{IO}$ ; no load normal mode   | 2.0  | 2.5  | 3.0  | V             |
| $I_{o(reces)}$ (CANH)                 | Recessive output current at pin CANH                                | $-30\text{ V} < V_{CANH} < +35\text{ V}$ ;<br>$0\text{ V} < V_{CC} < 5.5\text{ V}$                                     | -2.5 | -    | +2.5 | mA            |
| $I_{o(reces)}$ (CANL)                 | Recessive output current at pin CANL                                | $-30\text{ V} < V_{CANL} < +35\text{ V}$ ;<br>$0\text{ V} < V_{CC} < 5.5\text{ V}$                                     | -2.5 | -    | +2.5 | mA            |
| $I_{Ll}(CANH)$                        | Input leakage current to pin CANH                                   | $0\ \Omega < R(V_{CC}\text{ to GND}) < 1\text{ M}\Omega$<br>$V_{CANL} = V_{CANH} = 5\text{ V}$                         | -10  | 0    | 10   | $\mu\text{A}$ |
| $I_{Ll}(CANL)$                        | Input leakage current to pin CANL                                   |  | -10  | 0    | 10   | $\mu\text{A}$ |
| $V_{o(dom)}$ (CANH)                   | Dominant output voltage at pin CANH                                 | $V_{TxD} = 0\text{ V}$ ;<br>$V_{CC} = 4.75\text{ V to } 5.25\text{ V}$   | 3.0  | 3.6  | 4.25 | V             |
| $V_{o(dom)}$ (CANL)                   | Dominant output voltage at pin CANL                                 | $V_{TxD} = 0\text{ V}$ ;<br>$V_{CC} = 4.75\text{ V to } 5.25\text{ V}$   | 0.5  | 1.4  | 1.75 | V             |
| $V_{o(dif)}$ (bus_dom)                | Differential bus output voltage ( $V_{CANH} - V_{CANL}$ )           | $V_{TxD} = 0\text{ V}$ ; dominant;<br>$V_{CC} = 4.75\text{ V to } 5.25\text{ V}$<br>$45\ \Omega < R_{LT} < 65\ \Omega$ | 1.5  | 2.25 | 3.0  | V             |
| $V_{o(dif)}$ (bus_rec)                | Differential bus output voltage ( $V_{CANH} - V_{CANL}$ )           | $V_{TxD} = V_{IO}$ ; recessive;<br>no load   | -120 | 0    | +50  | mV            |
| $V_{o(sym)}$ (bus_dom)                | Bus output voltage symmetry<br>$V_{CANH} + V_{CANL}$                | $V_{TxD} = 0\text{ V}$<br>$V_{CC} = 4.75\text{ V to } 5.25\text{ V}$   | 0.9  | -    | 1.1  | $V_{CC}$      |
| $I_{o(sc)}$ (CANH)                    | Short circuit output current at pin CANH                            | $V_{CANH} = 0\text{ V}$ ; $V_{TxD} = 0\text{ V}$   | -90  | -70  | -40  | mA            |
| $I_{o(sc)}$ (CANL)                    | Short circuit output current at pin CANL                            | $V_{CANL} = 36\text{ V}$ ; $V_{TxD} = 0\text{ V}$  | 40   | 70   | 100  | mA            |
| $V_{i(dif)}$ (th)                     | Differential receiver threshold voltage                             | $-12\text{ V} < V_{CANL} < +12\text{ V}$ ;<br>$-12\text{ V} < V_{CANH} < +12\text{ V}$ ;                               | 0.5  | 0.7  | 0.9  | V             |
| $V_{ihcm(dif)}$ (th)                  | Differential receiver threshold voltage for high common-mode        | $-30\text{ V} < V_{CANL} < +35\text{ V}$ ;<br>$-30\text{ V} < V_{CANH} < +35\text{ V}$ ;                               | 0.40 | 0.7  | 1.0  | V             |
| $R_{i(cm)}$ (CANH)                    | Common-mode input resistance at pin CANH                            |  | 15   | 26   | 37   | k $\Omega$    |
| $R_{i(cm)}$ (CANL)                    | Common-mode input resistance at pin CANL                            |  | 15   | 26   | 37   | k $\Omega$    |
| $R_{i(cm)}$ (m)                       | Matching between pin CANH and pin CANL common mode input resistance | $V_{CANH} = V_{CANL}$  | -0.8 | 0    | +0.8 | %             |
| $R_{i(dif)}$                          | Differential input resistance                                       |  | 25   | 50   | 75   | k $\Omega$    |
| $C_{i(CANH)}$                         | Input capacitance at pin CANH                                       | $V_{TxD} = V_{IO}$ ; not tested  | -    | 7.5  | 20   | pF            |
| $C_{i(CANL)}$                         | Input capacitance at pin CANL                                       | $V_{TxD} = V_{IO}$ ; not tested  | -    | 7.5  | 20   | pF            |
| $C_{i(dif)}$                          | Differential input capacitance                                      | $V_{TxD} = V_{IO}$ ; not tested  | -    | 3.75 | 10   | pF            |

**THERMAL SHUTDOWN**

| $T_{J(sd)}$ | Shutdown junction temperature | Junction temperature rising | 160 | 180 | 200 | $^{\circ}\text{C}$ |
|-------------|-------------------------------|-----------------------------|-----|-----|-----|--------------------|
|             |                               |                             |     |     |     |                    |

**TIMING CHARACTERISTICS (see Figures 5 and 6)**

|                     |   |  |     |     |     |    |
|---------------------|---|--|-----|-----|-----|----|
| $t_{d(TxD-BUSon)}$  | Delay TxD to bus active                   | $C_i = 100\text{ pF}$ between CANH to CANL | -   | 75  | -   | ns |
| $t_{d(TxD-BUSoff)}$ | Delay TxD to bus inactive                 | $C_i = 100\text{ pF}$ between CANH to CANL | -   | 65  | -   | ns |
| $t_{d(BUSon-RxD)}$  | Delay bus active to RxD                   | $C_{rxd} = 15\text{ pF}$                   | -   | 70  | -   | ns |
| $t_{d(BUSoff-RxD)}$ | Delay bus inactive to RxD                 | $C_{rxd} = 15\text{ pF}$                   | -   | 70  | -   | ns |
| $t_{pd}$            | Propagation delay TxD to RxD (both edges) | $C_i = 100\text{ pF}$ between CANH to CANL | 90  | 140 | 245 | ns |
| $t_{dom(TxD)}$      | TxD dominant time for time-out            | $V_{TxD} = 0\text{ V}$                     | 1.5 | 2.5 | 5   | ms |

12. EN pin Only available on NCV7351-E version

13. Not tested in production. Guaranteed by design and prototype evaluation.



# NCV7351

## MEASUREMENT SETUPS AND DEFINITIONS

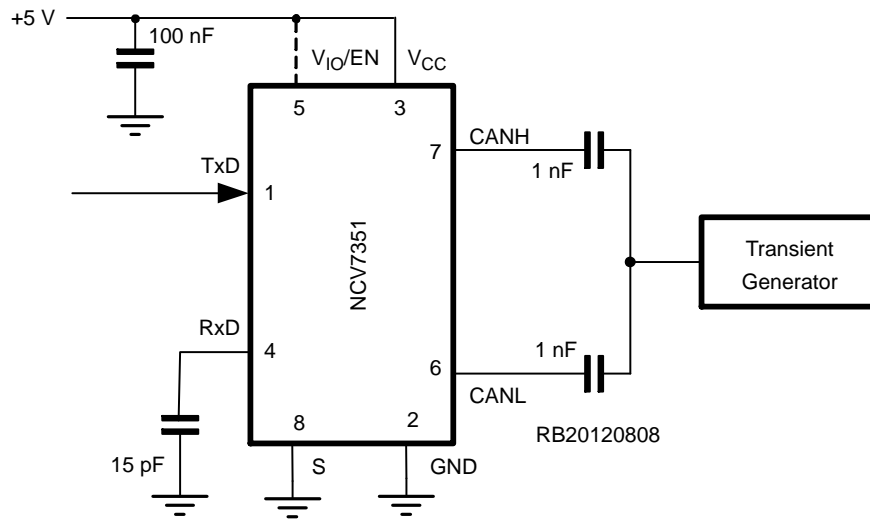

Figure 4. Test Circuit for Automotive Transients

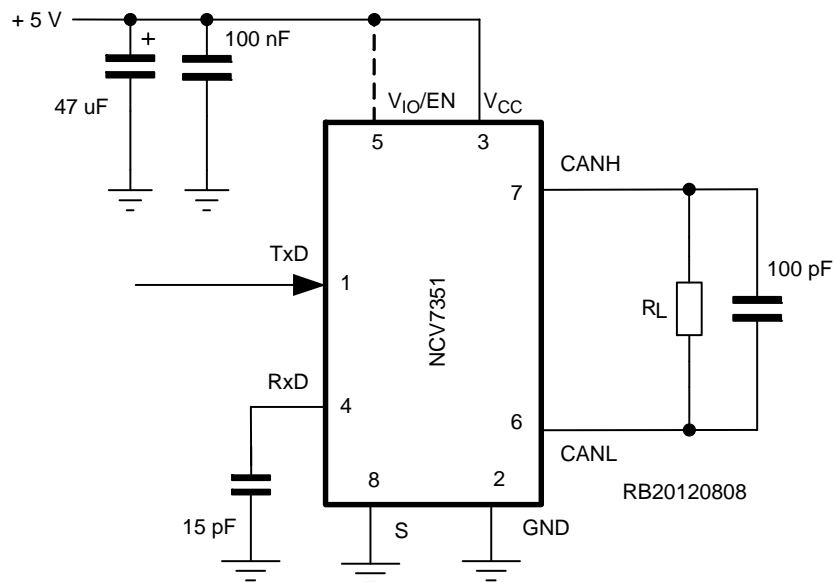
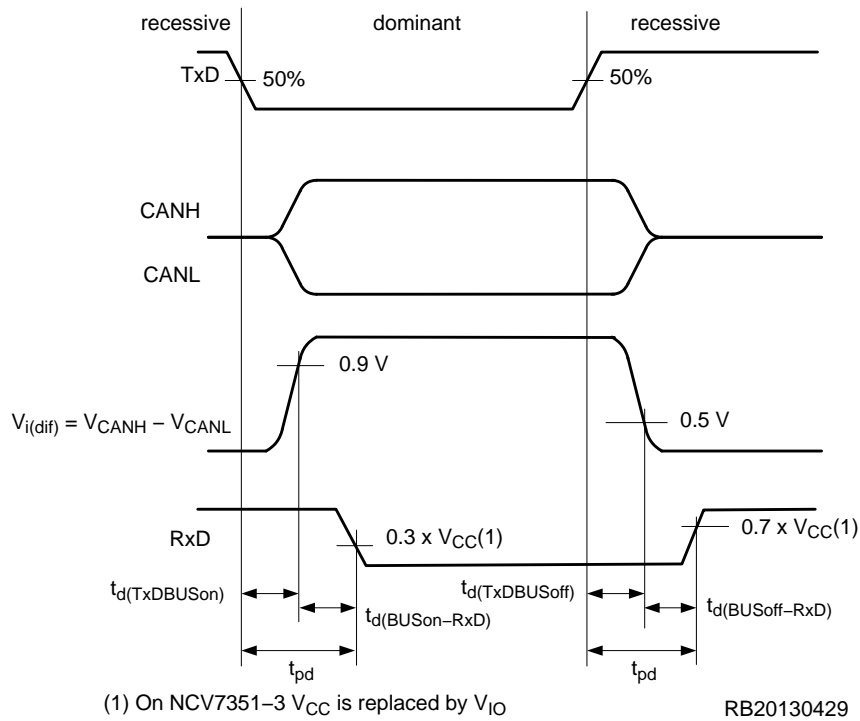

Figure 5. Test Circuit for Timing Characteristics

# NCV7351



**Figure 6. Transceiver Timing Diagram**

## DEVICE ORDERING INFORMATION

| Part Number   | Description                                  | Temperature Range | Package   | Shipping <sup>†</sup> |
|---------------|--|-------------------|---|-----------------------|
| NCV7351D13R2G | High Speed CAN Transceiver with $V_{IO}$ pin | -40°C to +125°C   | SOIC 150 8 GREEN (Matte Sn, JEDEC MS-012) (Pb-Free) | 3000 / Tape & Reel    |
| NCV7351D10R2G | High Speed CAN Transceiver with pin 5 NC     |                   |   |                       |
| NCV7351D1ER2G | High Speed CAN Transceiver with EN pin       |                   |   |                       |

<sup>†</sup>For information on tape and reel specifications, including part orientation and tape sizes, please refer to our Tape and Reel Packaging Specifications Brochure, BRD8011/D.

# NCV7351

## PACKAGE DIMENSIONS

SOIC 8  
CASE 751AZ  
ISSUE O

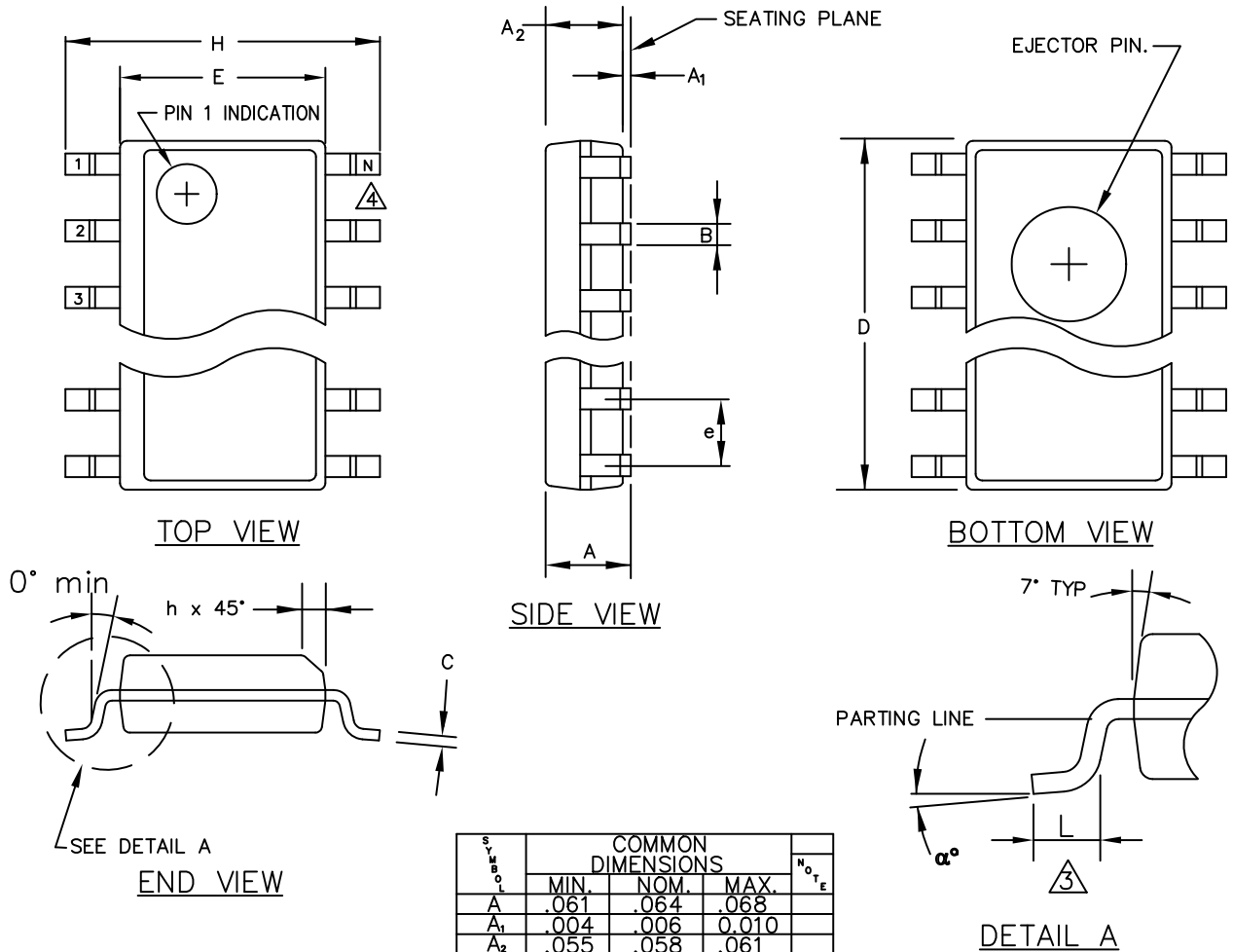

| SYMBOL         | COMMON DIMENSIONS |      |       | NOTE |
|----------------|-------------------|------|-------|------|
|                | MIN.              | NOM. | MAX.  |      |
| A              | .061              | .064 | .068  |      |
| A <sub>1</sub> | .004              | .006 | 0.010 |      |
| A <sub>2</sub> | .055              | .058 | .061  |      |
| B              | .0138             | .016 | .020  |      |
| C              | .0075             | .008 | .0098 |      |
| D              | SEE VARIATIONS    |      |       | 1    |
| E              | .150              | .155 | .157  |      |
| e              | .050 BSC          |      |       |      |
| H              | .230              | .236 | .244  |      |
| h              | .010              | .013 | .016  |      |
| L              | .016              | .025 | .035  |      |
| N              | SEE VARIATIONS    |      |       | 2    |
| α°             | 0°                | 5°   | 8°    |      |

| VARIATIONS |      |      |      |    |
|------------|------|------|------|----|
|            | 1    |      |      | 2  |
|            | D    |      |      | N  |
| NOTE       | MIN. | NOM. | MAX. |    |
| AA         | .189 | .194 | .196 | 8  |
| AB         | .337 | .342 | .344 | 14 |
| AC         | .386 | .391 | .393 | 16 |

1. ALL DIMENSIONS ARE IN MILLIMETERS.

**ON Semiconductor** and  are registered trademarks of Semiconductor Components Industries, LLC (SCILLC). SCILLC owns the rights to a number of patents, trademarks, copyrights, trade secrets, and other intellectual property. A listing of SCILLC's product/patent coverage may be accessed at [www.onsemi.com/site/pdf/Patent-Marking.pdf](http://www.onsemi.com/site/pdf/Patent-Marking.pdf). SCILLC reserves the right to make changes without further notice to any products herein. SCILLC makes no warranty, representation or guarantee regarding the suitability of its products for any particular purpose, nor does SCILLC assume any liability arising out of the application or use of any product or circuit, and specifically disclaims any and all liability, including without limitation special, consequential or incidental damages. "Typical" parameters which may be provided in SCILLC data sheets and/or specifications can and do vary in different applications and actual performance may vary over time. All operating parameters, including "Typicals" must be validated for each customer application by customer's technical experts. SCILLC does not convey any license under its patent rights nor the rights of others. SCILLC products are not designed, intended, or authorized for use as components in systems intended for surgical implant into the body, or other applications intended to support or sustain life, or for any other application in which the failure of the SCILLC product could create a situation where personal injury or death may occur. Should Buyer purchase or use SCILLC products for any such unintended or unauthorized application, Buyer shall indemnify and hold SCILLC and its officers, employees, subsidiaries, affiliates, and distributors harmless against all claims, costs, damages, and expenses, and reasonable attorney fees arising out of, directly or indirectly, any claim of personal injury or death associated with such unintended or unauthorized use, even if such claim alleges that SCILLC was negligent regarding the design or manufacture of the part. SCILLC is an Equal Opportunity/Affirmative Action Employer. This literature is subject to all applicable copyright laws and is not for resale in any manner.

## PUBLICATION ORDERING INFORMATION

### LITERATURE FULFILLMENT:

Literature Distribution Center for ON Semiconductor  
P.O. Box 5163, Denver, Colorado 80217 USA  
**Phone:** 303-675-2175 or 800-344-3860 Toll Free USA/Canada  
**Fax:** 303-675-2176 or 800-344-3867 Toll Free USA/Canada  
**Email:** [orderlit@onsemi.com](mailto:orderlit@onsemi.com)

**N. American Technical Support:** 800-282-9855 Toll Free  
USA/Canada  
**Europe, Middle East and Africa Technical Support:**  
Phone: 421 33 790 2910  
**Japan Customer Focus Center**  
Phone: 81-3-5817-1050

**ON Semiconductor Website:** [www.onsemi.com](http://www.onsemi.com)  
**Order Literature:** <http://www.onsemi.com/orderlit>  
For additional information, please contact your local  
Sales Representative

Компания «Океан Электроники» предлагает заключение долгосрочных отношений при поставках импортных электронных компонентов на взаимовыгодных условиях!

Наши преимущества:

- Поставка оригинальных импортных электронных компонентов напрямую с производств Америки, Европы и Азии, а так же с крупнейших складов мира;
- Широкая линейка поставок активных и пассивных импортных электронных компонентов (более 30 млн. наименований);
- Поставка сложных, дефицитных, либо снятых с производства позиций;
- Оперативные сроки поставки под заказ (от 5 рабочих дней);
- Экспресс доставка в любую точку России;
- Помощь Конструкторского Отдела и консультации квалифицированных инженеров;
- Техническая поддержка проекта, помощь в подборе аналогов, поставка прототипов;
- Поставка электронных компонентов под контролем ВП;
- Система менеджмента качества сертифицирована по Международному стандарту ISO 9001;
- При необходимости вся продукция военного и аэрокосмического назначения проходит испытания и сертификацию в лаборатории (по согласованию с заказчиком);
- Поставка специализированных компонентов военного и аэрокосмического уровня качества (Xilinx, Altera, Analog Devices, Intersil, Interpoint, Microsemi, Actel, Aeroflex, Peregrine, VPT, Syfer, Eurofarad, Texas Instruments, MS Kennedy, Miteq, Cobham, E2V, MA-COM, Hittite, Mini-Circuits, General Dynamics и др.);

Компания «Океан Электроники» является официальным дистрибьютором и эксклюзивным представителем в России одного из крупнейших производителей разъемов военного и аэрокосмического назначения «JONHON», а так же официальным дистрибьютором и эксклюзивным представителем в России производителя высокотехнологичных и надежных решений для передачи СВЧ сигналов «FORSTAR».



## JONHON

«JONHON» (основан в 1970 г.)

Разъемы специального, военного и аэрокосмического назначения:

(Применяются в военной, авиационной, аэрокосмической, морской, железнодорожной, горно- и нефтедобывающей отраслях промышленности)

«FORSTAR» (основан в 1998 г.)

ВЧ соединители, коаксиальные кабели, кабельные сборки и микроволновые компоненты:

(Применяются в телекоммуникациях гражданского и специального назначения, в средствах связи, РЛС, а так же военной, авиационной и аэрокосмической отраслях промышленности).



Телефон: 8 (812) 309-75-97 (многоканальный)

Факс: 8 (812) 320-03-32

Электронная почта: [ocean@oceanchips.ru](mailto:ocean@oceanchips.ru)

Web: <http://oceanchips.ru/>

Адрес: 198099, г. Санкт-Петербург, ул. Калинина, д. 2, корп. 4, лит. А