

System Lens Driver for Digital Still Cameras / Single-lens Reflex Cameras



# 5ch System Lens Drivers for Digital Still Cameras

**BD6370GUL, BD6758MWV, BD6758KN**

No.09014EAT01

## ●Description

The BD6370GUL motor driver provides 3 Constant-Voltage Drive / Full-ON Drive H-bridge channels, 1 Constant-Voltage Drive / Linear Constant-Current Drive / Full-ON Drive H-bridge channel, and 1 Constant-Current Drive H-bridge channel, while the BD6758MWV and the BD6758KN provides 4 Full-ON Drive H-bridge channels and 1 Linear Constant-Current Drive H-bridge channel.

A Stepping motor can be used for auto focus and a DC motor for zoom and iris. ROHM offers both an advance type equipped with a D/A converter in all channels and a standard type, allowing selection of the ideal unit depending on the application.

## ●Features

- 1) Subminiature 24PIN Wafer-level CSP (Chip Size Package): 2.6 x 2.6 x 0.55mm<sup>3</sup> (BD6370GUL)
- 2) Resemblance 6ch drive function (BD6370GUL)
- 3) Drive type selection (BD6370GUL)
- 4) Low ON-Resistance Power CMOS output:  
All blocks (Const.-V/Full-ON Drive, Const.-V/Const.-C/Full-ON Drive, and Const.-Current Drive) with 1.4Ω Typ. (BD6370GUL)  
Full-ON Drive block with 1.2Ω Typ. and Linear Constant-Current Drive block with 1.0Ω Typ. (BD6758MWV / KN)
- 5) Serial interface 3-line bus control input (BD6370GUL)
- 6) Built-in Constant-Voltage control 6-bit D/A converter and Constant-Current control 6-bit D/A converter resolution (BD6370GUL)
- 7) Built-in ±5% high-precision Constant-Voltage Driver (BD6370GUL)
- 8) Built-in ±3% high-precision Linear Constant-Current Driver
- 9) Constant-Voltage Drive block and Constant-Current Drive block features phase compensation capacitor-free design
- 10) 1.2V±3% high-precision reference voltage output (BD6758MWV / KN)
- 11) Drive mode switching function (BD6758MWV / KN)
- 12) UVLO (Under Voltage Lockout Protection) function
- 13) Built-in TSD (Thermal Shut Down) circuit
- 14) Standby current consumption: 0μA Typ.

## ●Absolute Maximum Ratings

Parameter	Symbol	Limit			Unit
		BD6370GUL	BD6758MWV	BD6758KN	
Power supply voltage	VCC	-0.3 to +6.5	0 to +7.0	0 to +7.0	V
Motor power supply voltage	VM	-0.3 to +6.5	0 to +7.0	0 to +7.0	V
Control input voltage	VIN	-0.3 to VCC+0.3	0 to VCC	0 to VCC	V
Power dissipation	Pd	830 <sup>※1</sup>	880 <sup>※2</sup>	875 <sup>※3</sup>	mW
Operating temperature range	Topr	-25 to +85	-25 to +85	-25 to +85	°C
Junction temperature	Tjmax	+150	+150	+150	°C
Storage temperature range	Tstg	-55 to +150	-55 to +150	-55 to +150	°C
H-bridge output current	Iout	-500 to +500 <sup>※4</sup>	-800 to +800 <sup>※4</sup>	-800 to +800 <sup>※4</sup>	mA/ch

※1 Reduced by 6.64mW/°C over 25°C, when mounted on a glass epoxy board (50mm × 58mm × 1.75mm; 8layers).

※2 Reduced by 7.0mW/°C over 25°C, when mounted on a glass epoxy board (74.2mm × 74.2mm × 1.6mm).

※3 Reduced by 7.0mW/°C over 25°C, when mounted on a glass epoxy board (70mm × 70mm × 1.6mm).

※4 Must not exceed Pd, ASO, or Tjmax of 150°C.

### ● Operating Conditions (Ta=-25 to +85°C)

Parameter	Symbol	Limit			Unit
		BD6370GUL	BD6758MWV	BD6758KN	
Power supply voltage	VCC	2.7 to 5.5	2.5 to 5.5	2.5 to 5.5	V
Motor power supply voltage	VM	2.7 to 5.5	2.5 to 5.5	2.5 to 5.5	V
Control input voltage	VIN	0 to VCC	0 to VCC	0 to VCC	V
Control input frequency	FIN	100 <sup>※5</sup>	100 <sup>※5</sup>	100 <sup>※5</sup>	kHz
Serial clock input frequency	FSCLK	10 <sup>※5</sup>	-	-	MHz
H-bridge output current	Iout	-400 to +400 <sup>※6</sup>	-500 to +500 <sup>※6</sup>	-500 to +500 <sup>※6</sup>	mA/ch

※5 ON duty=50%

※6 Must not exceed Pd or ASO.

### ● Electrical Characteristics and Diagrams

1) BD6370GUL Electrical DC Characteristics (Unless otherwise specified, Ta=25°C, VCC=3.0V, VM=5.0V)

Parameter	Symbol	Limit			Unit	Conditions
		Min.	Typ.	Max.		
Overall						
Circuit current (Standby mode)	ICCST	-	0	3.0	μA	PS=0V
Circuit current (Active mode)	ICC	-	1.3	2.0	mA	PS=3V with no control signal, and no load
Control input (IN=PS, INPUT1, 2, 34, 45, STROBE, SCLK, and SDATA)						
High level input voltage	VINH	2.0	-	VCC	V	
Low level input voltage	VINL	0	-	0.7	V	
High level input current 1	IINH1	15	30	60	μA	VINH1 (PS, INPUT1, 2, 34, 45) =3V
High level input current 2	IINH2	7.5	15	30	μA	VINH2 (STROBE, SCLK, SDATA) =3V
Low level input current	IINL	-1	0	-	μA	VINL=0V
UVLO						
UVLO voltage	VUVLO	1.6	-	2.4	V	
Constant-Voltage Drive / Full-ON Drive block (ch1 to ch3)						
Output ON-Resistance	RON	-	1.40	1.75	Ω	I <sub>o</sub> =±400mA on high and low sides in total
Output high voltage 1	VVOH1	1.35	1.50	1.65	V	DACx=6'b01_0100, RL=20Ω
Output high voltage 2	VVOH2	2.85	3.00	3.15	V	DACx=6'b10_1000, RL=20Ω
Output high voltage 3	VVOH3	4.49	4.725	4.96	V	DACx=6'b11_1111, RL=20Ω
DAC resolution	DVRES	-	6	-	BITS	75mV/LSB
Differential non-linear tolerance	DVDNL	-1	-	1	LSB	
Integral non-linear tolerance	DVINL	-2	-	2	LSB	
Min. voltage of DAC setting	DVRNG	1.5	-	-	V	DACx=6'b01_0100
Constant-Voltage Drive / Constant-Current Drive / Full-ON Drive block (ch4)						
Output ON-Resistance	RON	-	1.40	1.75	Ω	I <sub>o</sub> =±400mA on high and low sides in total
Constant-Voltage Drive block in ch4						
Output high voltage 1	VVOH1	1.35	1.50	1.65	V	DACV4=6'b01_0100, RL=20Ω
Output high voltage 2	VVOH2	2.85	3.00	3.15	V	DACV4=6'b10_1000, RL=20Ω
Output high voltage 3	VVOH3	4.49	4.725	4.96	V	DACV4=6'b11_1111, RL=20Ω
DAC resolution	DVRES	-	6	-	BITS	75mV/LSB
Differential non-linear tolerance	DVDNL	-1	-	1	LSB	
Integral non-linear tolerance	DVINL	-2	-	2	LSB	
Min. voltage of DAC setting	DVRNG	1.5	-	-	V	DACV4=6'b01_0100
Constant-Current Drive block in ch4						
RNF voltage 1	VIRNF1	40	50	60	mV	DACI4=6'b00_1010, R <sub>RNF4</sub> =0.5Ω, RL=10Ω
RNF voltage 2	VIRNF2	94	99	104	mV	DACI4=6'b01_0100, R <sub>RNF4</sub> =0.5Ω, RL=10Ω
RNF voltage 3	VIRNF3	178	198	218	mV	DACI4=6'b10_1000, R <sub>RNF4</sub> =0.5Ω, RL=10Ω
DAC resolution	DIRES	-	6	-	BITS	5mV/LSB
Differential non-linear tolerance	DIDNL	-1	-	1	LSB	
Integral non-linear tolerance	DIINL	-2	-	2	LSB	
Min. voltage of DAC setting	DIRNG	50	-	-	mV	DACI4=6'b00_1010
Constant-Current Drive block (ch5)						
Output ON-Resistance	RON	-	1.4	1.75	Ω	I <sub>o</sub> =±400mA on high and low sides in total
RNF voltage 1	VIRNF1	38	48	58	mV	DAC5=6'b00_1010, R <sub>RNF5</sub> =0.5Ω, RL=10Ω
RNF voltage 2	VIRNF2	91	96	101	mV	DAC5=6'b01_0100, R <sub>RNF5</sub> =0.5Ω, RL=10Ω
RNF voltage 3	VIRNF3	172	192	212	mV	DAC5=6'b10_1000, R <sub>RNF5</sub> =0.5Ω, RL=10Ω
DAC resolution	DIRES	-	6	-	BITS	5mV/LSB
Differential non-linear tolerance	DIDNL	-1	-	1	LSB	
Integral non-linear tolerance	DIINL	-2	-	2	LSB	
Min. voltage of DAC setting	DIRNG	50	-	-	mV	DAC5=6'b00_1010

2) BD6370GUL Electrical DC Characteristic Diagrams

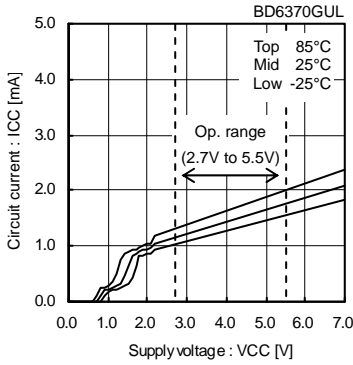

Fig.1 Circuit Current (Active mode)

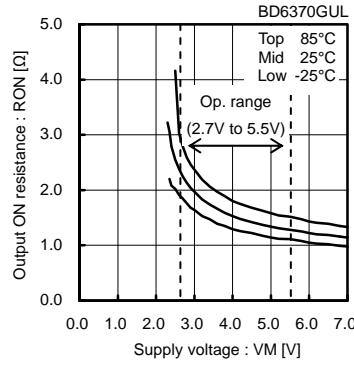

Fig.2 Output ON-Resistance (ch1 to ch3)

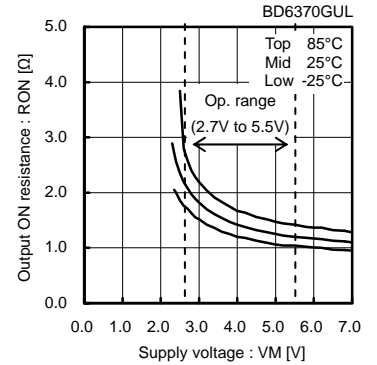

Fig.3 Output ON-Resistance (ch4 to ch5)

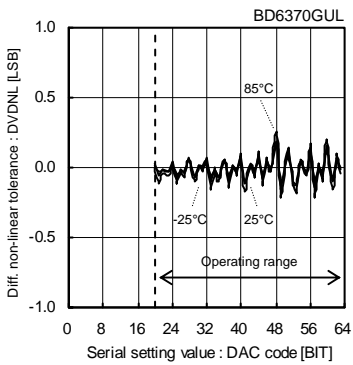

Fig.4 Differential Non-Linear Tolerance

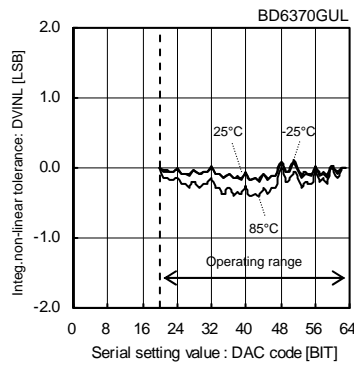

Fig.5 Integral Non-Linear Tolerance (Const.-Voltage drive block,  $R_L=20\Omega$ )

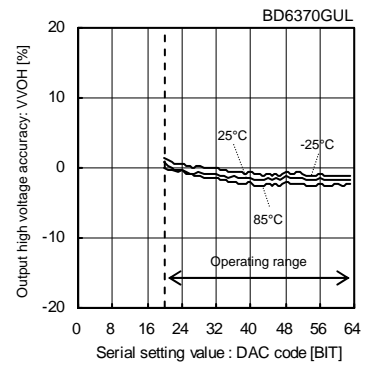

Fig.6 Output High Voltage Accuracy (Const.-Voltage drive block,  $R_L=20\Omega$ )

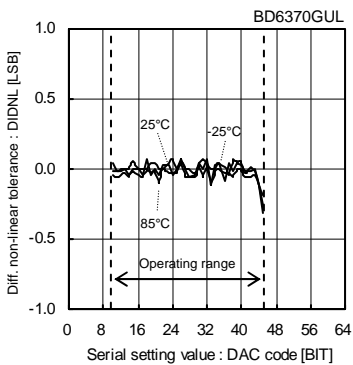

Fig.7 Differential Non-Linear Tolerance

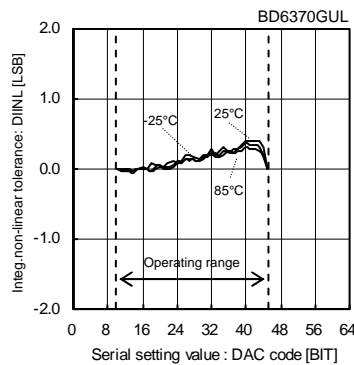

Fig.8 Integral Non-Linear Tolerance (Const.-Current drive block,  $R_{RNFx}=0.5\Omega$ ,  $R_L=10\Omega$ )

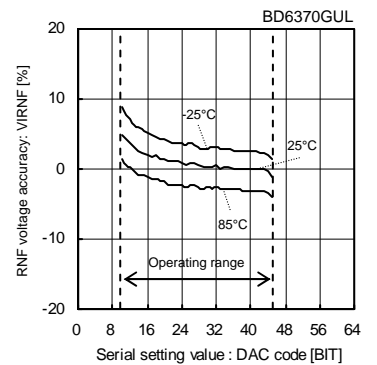

Fig.9 RNF Voltage Accuracy (Const.-Current drive block,  $R_{RNFx}=0.5\Omega$ ,  $R_L=10\Omega$ )

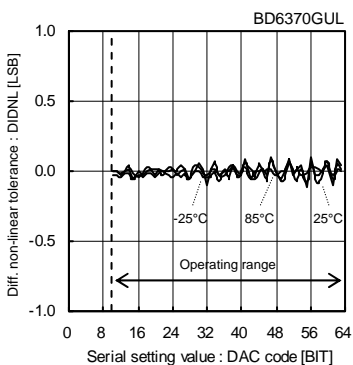

Fig.10 Differential Non-Linear Tolerance

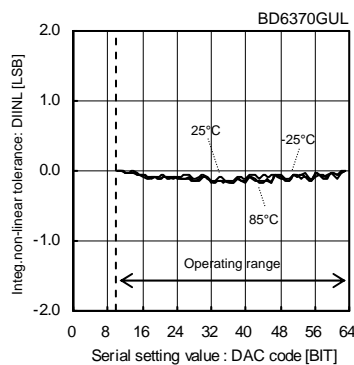

Fig.11 Integral Non-Linear Tolerance

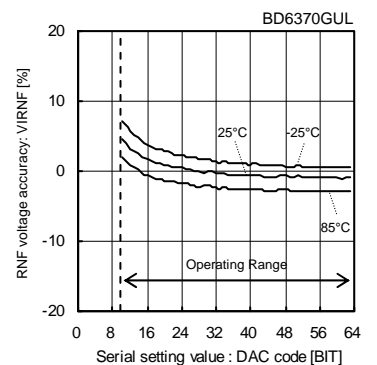

Fig.12 RNF Voltage Accuracy (Const.-Current drive block,  $R_{RNFx}=1.0\Omega$ ,  $R_L=10\Omega$ )

3) BD6370GUL Electrical AC Characteristics (Unless otherwise specified, Ta=25°C, VCC=3.0V, VM=5.0V)

Constant-Voltage / Full-ON Type Drive blocks (ch1 to ch3)

Parameter	Symbol	Information※7			Unit	Conditions
		ch1	ch2	ch3		
Full-ON Drive Mode						
Turn on time	ton	1.11	1.04	1.10	μs	DACx=6'b11_1111, RL=20Ω
Turn off time	toff	0.06	0.06	0.06	μs	
Rise time	tr	1.64	1.42	1.50	μs	
Fall time	tf	0.01	0.01	0.01	μs	
Constant-Voltage Drive Mode						
Turn on time	ton	1.26	1.23	1.22	μs	DACx=6'b10_1000, RL=20Ω
Turn off time	toff	0.04	0.04	0.04	μs	
Rise time	tr	1.31	1.35	1.30	μs	
Fall time	tf	0.02	0.02	0.02	μs	

Constant-Voltage / Constant-Current / Full-ON Type Drive block (ch4)

Parameter	Symbol	Information※7			Unit	Conditions
		-	ch4	-		
Full-ON Drive Mode						
Turn on time	ton	-	0.76	-	μs	DACV4=6'b11_1111, DACI4=6'b11_1111, RL=20Ω
Turn off time	toff	-	0.05	-	μs	
Rise time	tr	-	0.68	-	μs	
Fall time	tf	-	0.02	-	μs	
Constant-Voltage Drive Mode						
Turn on time	ton	-	1.19	-	μs	DACV4=6'b10_1000, DACI4=6'b11_1111, RL=20Ω
Turn off time	toff	-	0.04	-	μs	
Rise time	tr	-	1.31	-	μs	
Fall time	tf	-	0.01	-	μs	
Constant-Current Drive Mode						
Turn on time	ton	-	0.83	-	μs	DACV4=6'b11_1111, DACI4=6'b10_1100 (I <sub>O</sub> =400mA), R <sub>RNF4</sub> =0.5Ω, RL=10Ω, R <sub>METAL4</sub> =4mΩ, R <sub>W</sub> =40mΩ
Turn off time	toff	-	0.05	-	μs	
Rise time	tr	-	0.89	-	μs	
Fall time	tf	-	0.03	-	μs	
Turn on time	ton	-	0.69	-	μs	DACV4=6'b11_1111, DACI4=6'b10_1010 (I <sub>O</sub> =200mA), R <sub>RNF4</sub> =1.0Ω, RL=10Ω, R <sub>METAL4</sub> =4mΩ, R <sub>W</sub> =40mΩ
Turn off time	toff	-	0.04	-	μs	
Rise time	tr	-	0.29	-	μs	
Fall time	tf	-	0.03	-	μs	

Constant-Current Type Drive block (ch5)

Parameter	Symbol	Information※7			Unit	Conditions
		-	ch5	-		
Constant-Current Drive Mode						
Turn on time	ton	-	0.77	-	μs	DAC5=6'b10_1101 (I <sub>O</sub> =400mA), R <sub>RNF5</sub> =0.5Ω, RL=10Ω, R <sub>METAL5</sub> =22mΩ, R <sub>W</sub> =40mΩ
Turn off time	toff	-	0.04	-	μs	
Rise time	tr	-	0.47	-	μs	
Fall time	tf	-	0.04	-	μs	
Turn on time	ton	-	0.69	-	μs	DAC5=6'b10_1010 (I <sub>O</sub> =200mA), R <sub>RNF5</sub> =1.0Ω, RL=10Ω, R <sub>METAL5</sub> =22mΩ, R <sub>W</sub> =40mΩ
Turn off time	toff	-	0.04	-	μs	
Rise time	tr	-	0.24	-	μs	
Fall time	tf	-	0.02	-	μs	

※7 AC characteristics are reference values, then the performance of IC's characteristics is not guaranteed.

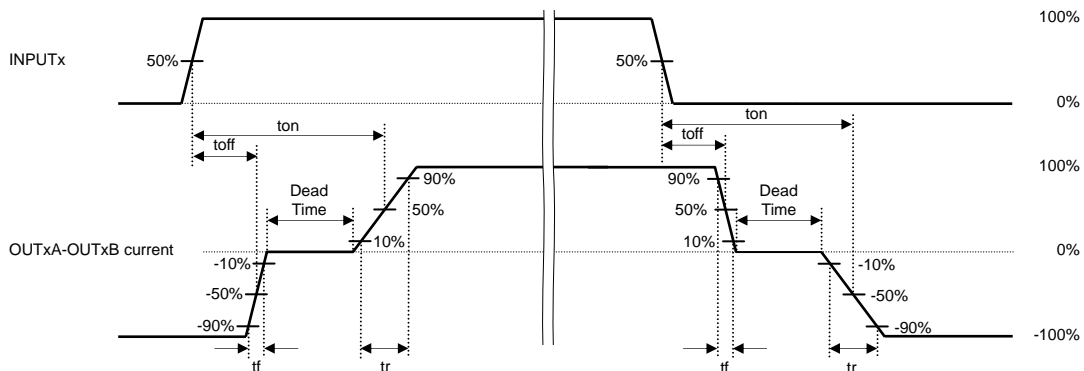

Fig.13 The Definition of I/O Switching Waveforms

4) BD6370GUL Electrical AC Characteristic Diagrams

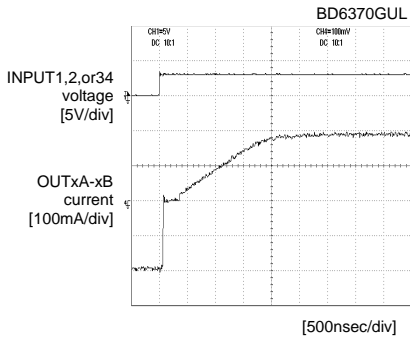

Fig.14 I/O AC Responses (ton, tr)  
 ch1 to ch3 Full-ON Drive Mode  
 DACx=6'b11\_1111, RL=20Ω

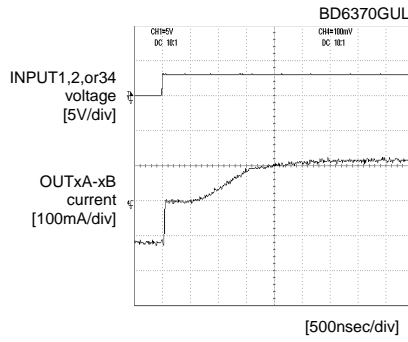

Fig.15 I/O AC Responses (ton, tr)  
 ch1 to ch3 Constant-Voltage Drive Mode  
 DACx=6'b10\_1000, RL=20Ω

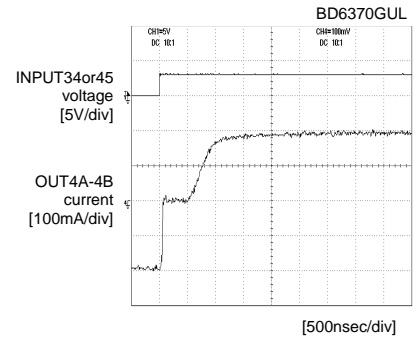

Fig.16 I/O AC Responses (ton, tr)  
 ch4 Full-ON Drive Mode  
 DACV4=DACI4=6'b11\_1111, RL=20Ω

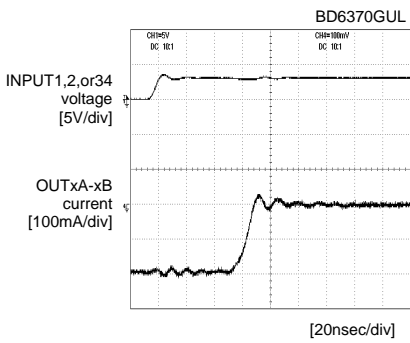

Fig.17 I/O AC Responses (toff, tf)  
 ch1 to ch3 Full-ON Drive Mode  
 DACx=6'b11\_1111, RL=20Ω

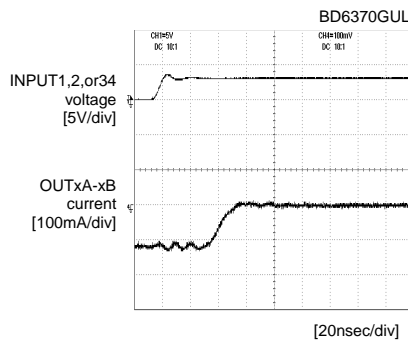

Fig.18 I/O AC Responses (toff, tf)  
 ch1 to ch3 Constant-Voltage Drive Mode  
 DACx=6'b10\_1000, RL=20Ω

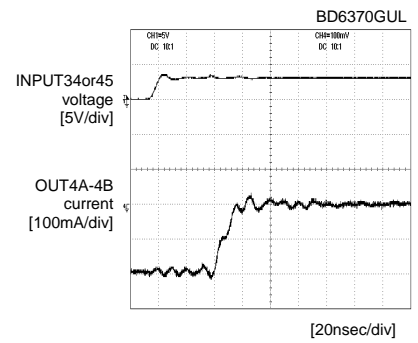

Fig.19 I/O AC Responses (toff, tf)  
 ch4 Full-ON Drive Mode  
 DACV4=DACI4=6'b11\_1111, RL=20Ω

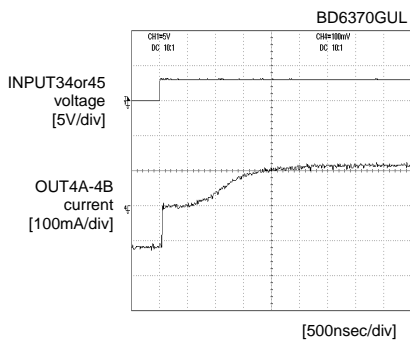

Fig.20 I/O AC Responses (ton, tr)  
 ch4 Constant-Voltage Drive Mode  
 DACV4=6'b10\_1000, DACI4=6'b11\_1111, RL=20Ω

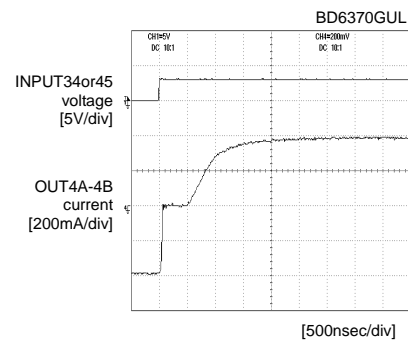

Fig.21 I/O AC Responses (ton, tr)  
 ch4 Constant-Current Drive Mode  
 DACV4=6'b11\_1111, DACI4=6'b10\_1100, RRNF4=0.5Ω, RL=10Ω

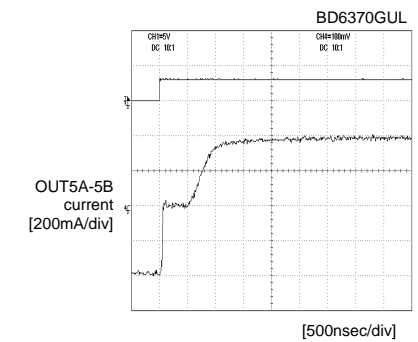

Fig.22 I/O AC Responses (ton, tr)  
 ch5 Constant-Current Drive Mode  
 DAC5=6'b10\_1101, RRNF5=0.5Ω, RL=10Ω

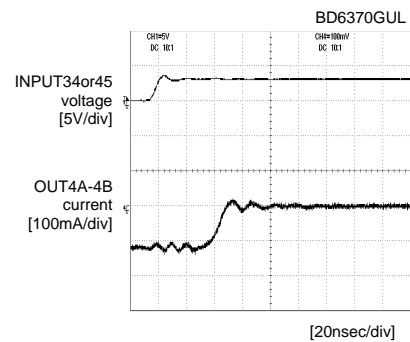

Fig.23 I/O AC Responses (toff, tf)  
 ch4 Constant-Voltage Drive Mode  
 DACV4=6'b10\_1000, DACI4=6'b11\_1111, RL=20Ω

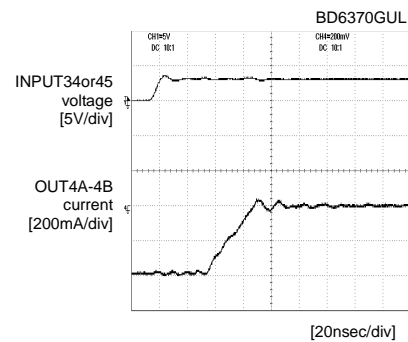

Fig.24 I/O AC Responses (toff, tf)  
 ch4 Constant-Current Drive Mode  
 DACV4=6'b11\_1111, DACI4=6'b10\_1100, RRNF4=0.5Ω, RL=10Ω

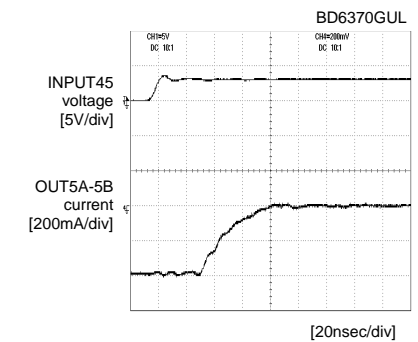

Fig.25 I/O AC Responses (toff, tf)  
 ch5 Constant-Current Drive Mode  
 DAC5=6'b10\_1101, RRNF5=0.5Ω, RL=10Ω

AC characteristics are reference values, then the performance of IC's characteristics is not guaranteed.

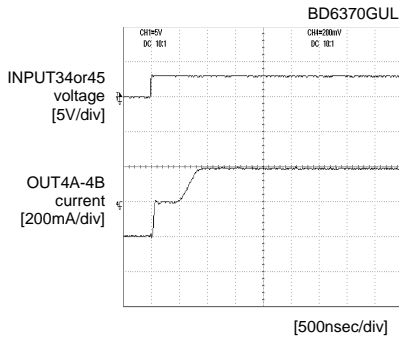

Fig.26 I/O AC Responses (ton, tr)  
ch4 Constant-Current Drive Mode

DACV4=6'b11\_1111, DACI4=6'b10\_1010,  $R_{RNF4}=1.0\Omega$ ,  $R_L=10\Omega$

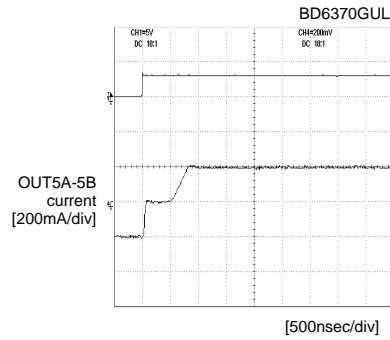

Fig.27 I/O AC Responses (ton, tr)  
ch5 Constant-Current Drive Mode

DAC5=6'b10\_1010,  $R_{RNF5}=1.0\Omega$ ,  $R_L=10\Omega$

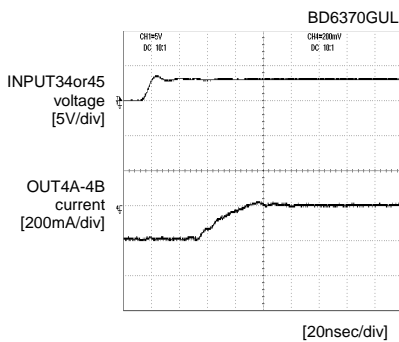

Fig.28 I/O AC Responses (toff, tf)  
ch4 Constant-Current Drive Mode

DACV4=6'b11\_1111, DACI4=6'b10\_1010,  $R_{RNF4}=1.0\Omega$ ,  $R_L=10\Omega$

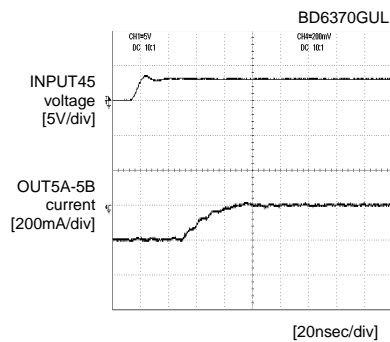

Fig.29 I/O AC Responses (toff, tf)  
ch5 Constant-Current Drive Mode

DAC5=6'b10\_1010,  $R_{RNF5}=1.0\Omega$ ,  $R_L=10\Omega$

**AC characteristics are reference values, then the performance of IC's characteristics is not guaranteed.**

5) BD6758MWV and BD6758KN Electrical Characteristics (Unless otherwise specified,  $T_a=25^\circ\text{C}$ ,  $V_{CC}=3.0\text{V}$ ,  $V_M=5.0\text{V}$ )

Parameter	Symbol	Limit			Unit	Conditions
		Min.	Typ.	Max.		
<b>Overall</b>						
Circuit current during standby operation	ICCST	-	0	10	$\mu\text{A}$	PS=0V
Circuit current	ICC	-	1.4	2.5	mA	PS=VCC with no signal
<b>Control input (IN=PS, IN1A to 5B, SEL1 to 2, BRK1 to 2, EN1, and IN5)</b>						
High level input voltage	VINH	2.0	-	-	V	
Low level input voltage	VINL	-	-	0.7	V	
High level input current	IINH	15	30	60	$\mu\text{A}$	VINH=3V
Low level input current	IINL	-1	0	-	$\mu\text{A}$	IVINL=0V
Pull-down resistor	RIN	50	100	200	k $\Omega$	
<b>UVLO</b>						
UVLO voltage	VUVLO	1.6	-	2.4	V	
<b>Full-ON Drive block (ch1 to ch4)</b>						
Output ON-Resistance	RON	-	1.2	1.5	$\Omega$	$I_o=\pm 400\text{mA}$ on high and low sides in total
<b>Linear Constant-Current Drive block (ch5)</b>						
Output ON-Resistance	RON	-	1.0	1.25	$\Omega$	$I_o=\pm 400\text{mA}$ on high and low sides in total
VREF output voltage	VREF	1.16	1.20	1.24	V	$I_{out}=0\sim 1\text{mA}$
Output limit voltage	VOL	194	200	206	mV	$R_{NF}=0.5\Omega$ , $V_{LIM}=0.2\text{V}$

6) BD6758MWV and BD6758KN Electrical AC Characteristic Diagrams

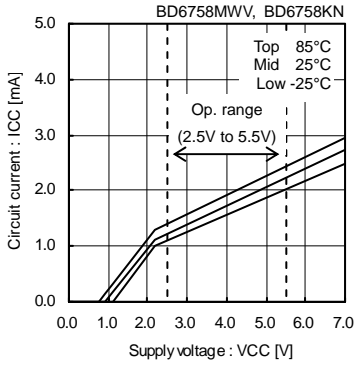

Fig.30 Circuit current

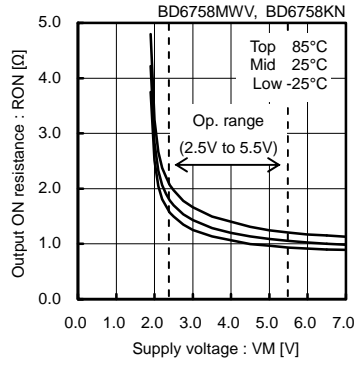

Fig.31 Output ON-Resistance (Full-ON Drive block)

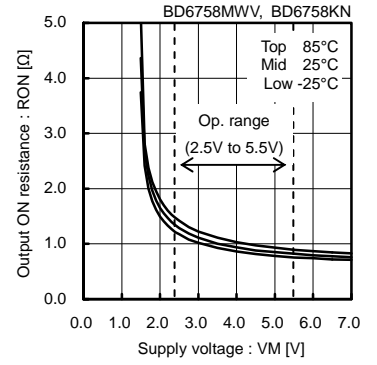

Fig.32 Output ON-Resistance (Linear Constant-Current Drive block)

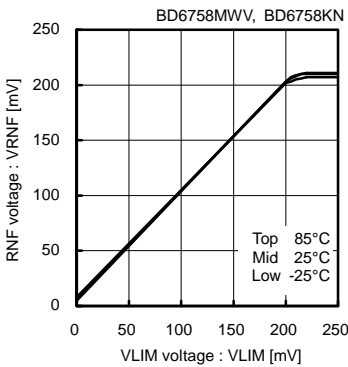

Fig.33 Output limit voltage (RNF=0.5Ω)

● Power Dissipation Reduction

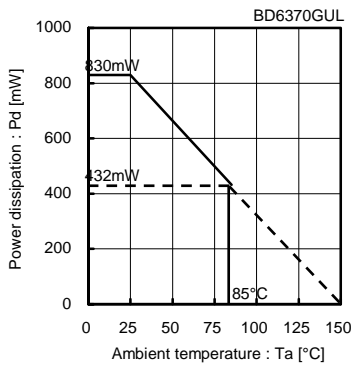

Fig.34 Power Dissipation Reduction

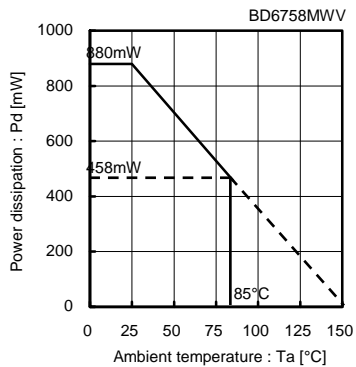

Fig.35 Power Dissipation Reduction

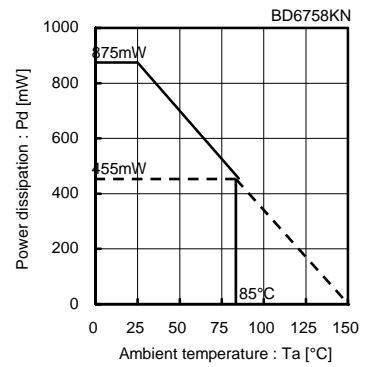

Fig.36 Power Dissipation Reduction

●Block Diagram, Pin Arrangement, and Pin Function

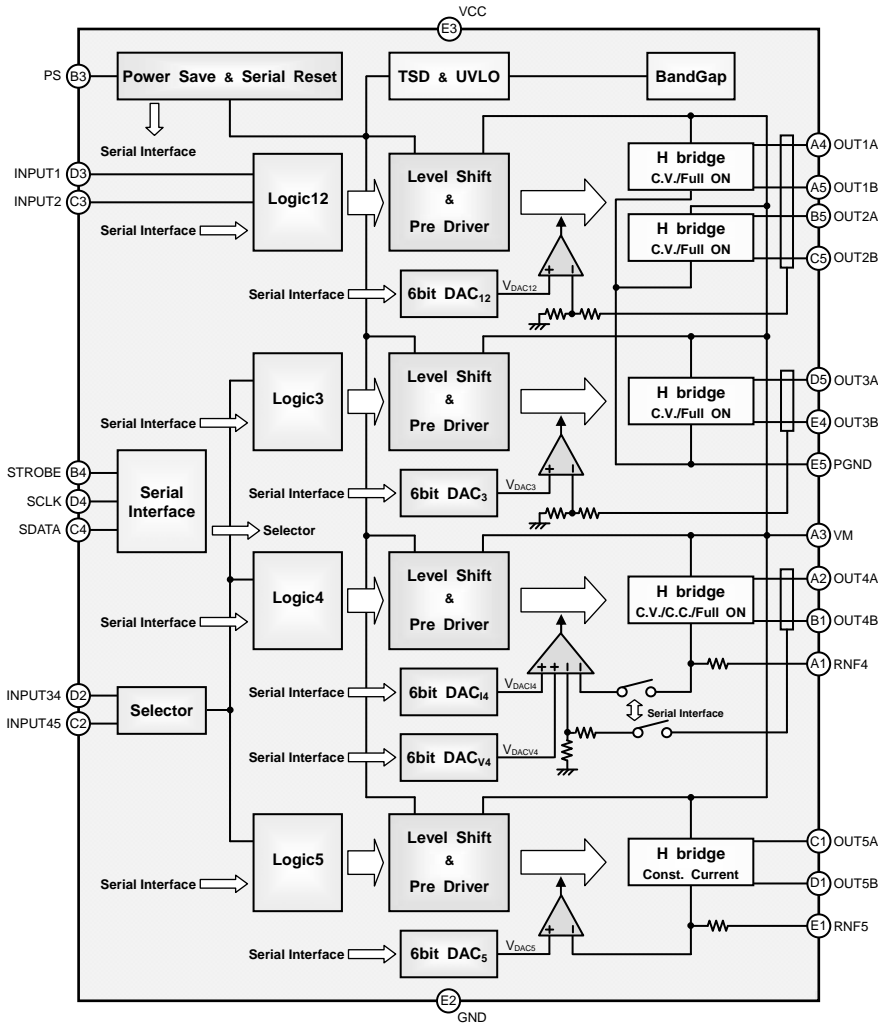

Fig.37 BD6370GUL Block Diagram

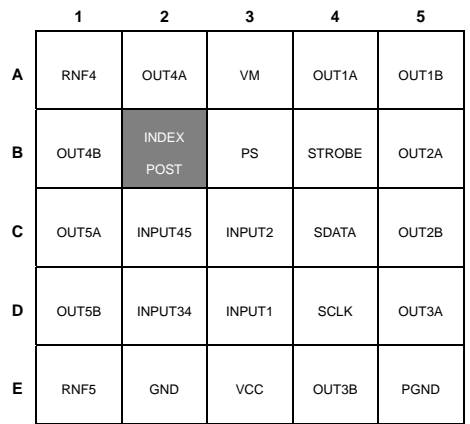

Fig.38 BD6370GUL Pin Arrangement (Top View) VCSP50L2 Package

BD6370GUL Pin Function Table

No.	Pin Name	Function	No.	Pin Name	Function
A1	RNF4	Resistance connection pin for output current detection ch4	D1	OUT5B	H-bridge output pin ch5 B
A2	OUT4A	H-bridge output pin ch4 A	D2	INPUT34	Control input pin ch3 or ch4
A3	VM	Motor power supply pin	D3	INPUT1	Control input pin ch1
A4	OUT1A	H-bridge output pin ch1 A	D4	SCLK	Serial clock input pin
A5	OUT1B	H-bridge output pin ch1 B	D5	OUT3A	H-bridge output pin ch3 A
B1	OUT4B	H-bridge output pin ch4 B	E1	RNF5	Resistance connection pin for output current detection ch5
B2	INDEX POST	-	E2	GND	Ground pin
B3	PS	Power-saving pin	E3	VCC	Power supply pin
B4	STROBE	Serial enable input pin	E4	OUT3B	H-bridge output pin ch3 B
B5	OUT2A	H-bridge output pin ch2 A	E5	PGND	Motor ground pin ch1 to ch3
C1	OUT5A	H-bridge output pin ch5 A			
C2	INPUT45	Control input pin ch4 or ch5			
C3	INPUT2	Control input pin ch2			
C4	SDATA	Serial data input pin			
C5	OUT2B	H-bridge output pin ch2 B			



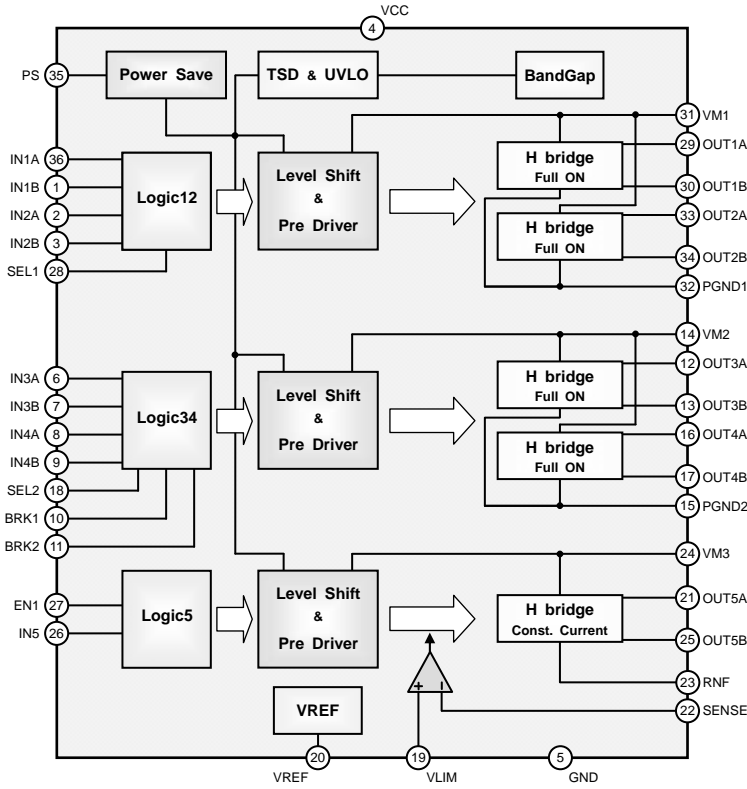

Fig.39 BD6758KN Block Diagram

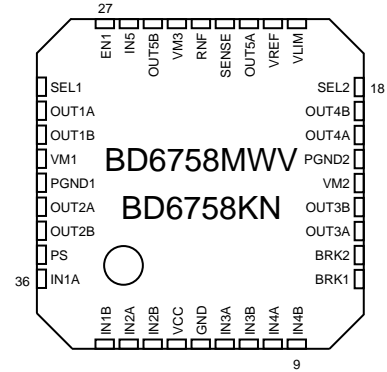

Fig.40 BD6758MWV / KN Pin Arrangement (Top View)  
 MWV=UQFN036V5050 Package  
 KN=VQFN36 Package

BD6758KN Pin Function Table

No.	Pin Name	Function	No.	Pin Name	Function
1	IN1B	Control input pin ch1 B	19	VLIM	Output current setting pin ch5
2	IN2A	Control input pin ch2 A	20	VREF	Reference voltage output pin
3	IN2B	Control input pin ch2 B	21	OUT5A	H-bridge output pin ch5 A
4	VCC	Power supply pin	22	SENSE	Output current detection ch5
5	GND	Ground pin	23	RNF	Resistance connection pin for output current detection ch5
6	IN3A	Control input pin ch3 A	24	VM3	Motor power supply pin ch5
7	IN3B	Control input pin ch3 B	25	OUT5B	H-bridge output pin ch5 B
8	IN4A	Control input pin ch4 A	26	IN5	Control input pin ch5 INPUT
9	IN4B	Control input pin ch4 B	27	EN1	Control input pin ch5 ENABLE
10	BRK1	Control input pin ch3 BRAKE	28	SEL1	Drive mode selection pin ch1 and ch2
11	BRK2	Control input pin ch4 BRAKE	29	OUT1A	H-bridge output pin ch1 A
12	OUT3A	H-bridge output pin ch3 A	30	OUT1B	H-bridge output pin ch1 B
13	OUT3B	H-bridge output pin ch3 B	31	VM1	Motor power supply pin ch1 and ch2
14	VM2	Motor power supply pin ch3 and ch4	32	PGND1	Motor ground pin ch1 and ch2
15	PGND2	Motor ground pin ch3 and ch4	33	OUT2A	H-bridge output pin ch2 A
16	OUT4A	H-bridge output pin ch4 A	34	OUT2B	H-bridge output pin ch2 B
17	OUT4B	H-bridge output pin ch4 B	35	PS	Power saving pin
18	SEL2	Drive mode selection pin ch3 and ch4	36	IN1A	Control input pin ch1 A

●BD6370GUL Function Explanation

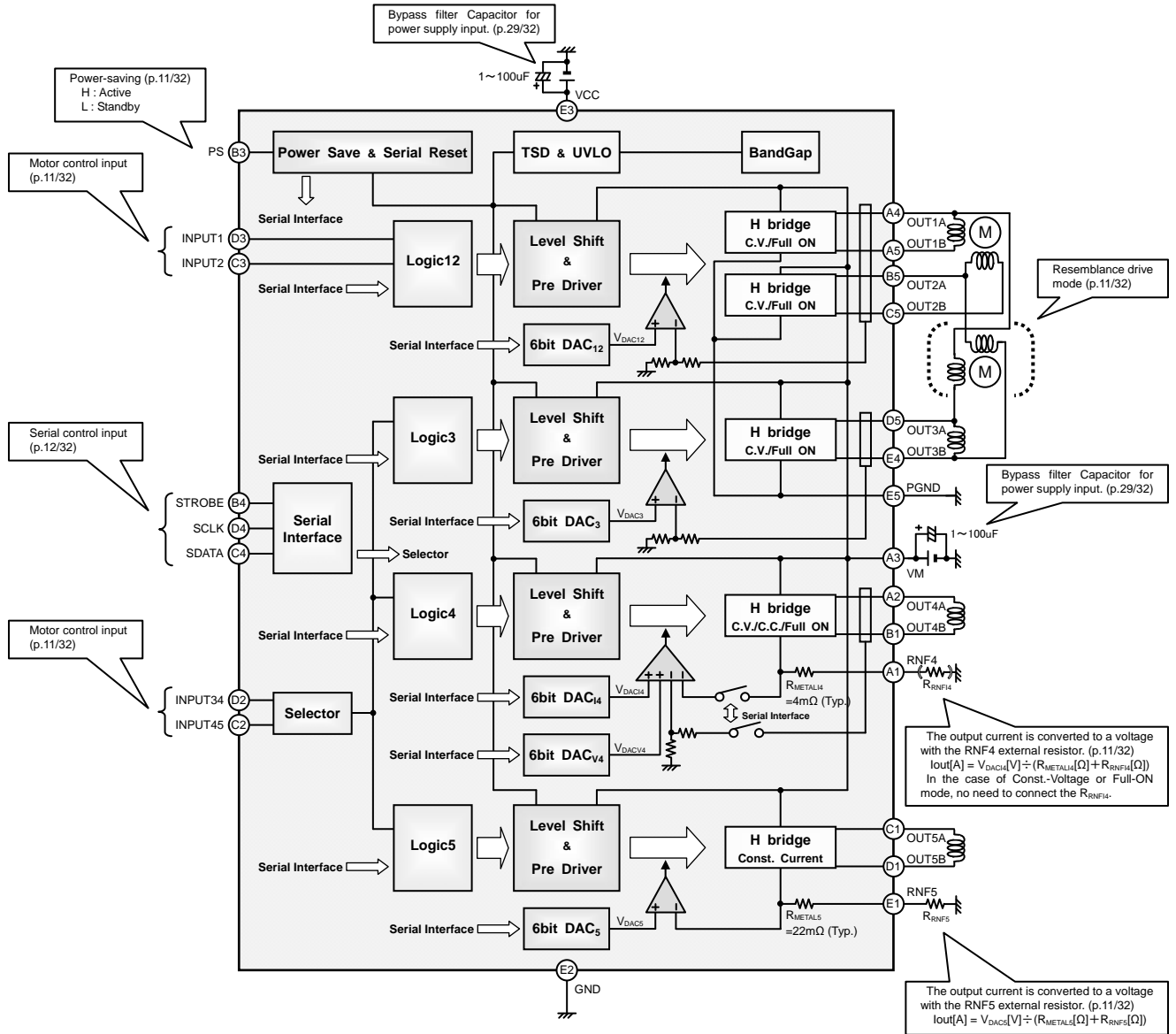

Fig.41 BD6370GUL Application Circuit Diagram

- 1) Power saving and Serial Reset (BD6370GUL; PS)
  - (1) Function Explanation ..... p.11/32
- 2) Control Input (BD6370GUL; INPUTx)
  - (1) Function Explanation ..... p.11/32
- 3) H-bridge (BD6370GUL; VM, OUTxA, OUTxB, and RNFx)
  - (1) Function Explanation ..... p.11/32
  - (2) The D/A Converter Settings of Constant-Voltage, Constant-Current, and Full-ON Mode ..... p.11/32
- 4) Serial Input (BD6370GUL; STROBE, SCLK, and SDATA)
  - (1) Function Explanation ..... p.12/32
  - (2) Serial Register Bit Map ..... p.12/32
- 5) Serial Register Data Bit Function (BD6370GUL)
  - (1) Address Bit [000] Function Explanation ..... p.13/32 to p.14/32
  - (2) Address Bit [001] Function Explanation ..... p.15/32
  - (3) Address Bit [010] Function Explanation ..... p.16/32 to p.17/32
  - (4) Address Bit [011] Function Explanation ..... p.18/32 to p.19/32
  - (5) Address Bit [100] Function Explanation ..... p.20/32
- 6) I/O Truth Table (BD6370GUL) ..... p.21/32 to p.23/32
- 7) The More Precise Constant-Current Settings (BD6370GUL) ..... p.24/32 to p.23/32
- 8) Application Control Sequence (BD6370GUL)
  - (1) Stepping Motor drive controlled by 2 phases mode ..... p.25/32 to p.26/32

## 1) Power-saving and Serial Reset (BD6370GUL; PS)

## (1) Function Explanation

When Low-level voltage is applied to PS pin, the IC will be turned off internally and the circuit current will be 0 $\mu$ A (Typ.). During operating mode, PS pin should be High-level. (See the Electrical Characteristics; p.2/32)

Be cancelled power saving mode after turned on power supply VCC and VM, because of PS terminal combines power saving with serial reset function. If the case of power saving terminal always shorted power supply terminal, reset function may not be well, and it may cause the IC to malfunction. (See the Sequence of Serial Control Input; p.12/32)

## 2) Motor Control Input (BD6370GUL; INPUTx)

## (1) Function Explanation

These pins are used to program and control the motor drive modes. So INPUTx switches CW or CCW, CW or Brake, and CCW or Brake, using serial function. (See the Electrical Characteristics; p.2/32 and I/O Truth Table; p.21/32 to p.23/32)

INPUT34 and INPUT45 pins drive ch3 or ch4, and ch4 or ch5, respectively. The driven channel is selected using serial function. (See the Driven Outputs for INPUT Terminal Table; p.14/32)

## 3) H-bridge (BD6370GUL; VM, OUTxA, OUTxB, and RNFx)

## (1) Function Explanation

The H-bridge output transistors of BD6370GUL are Power CMOS Drivers. The total H-bridge ON-Resistance on the high and low sides varies with the VM voltage. The system must be designed so that the maximum H-bridge current for each channel is 500mA or below.

The 3 H-bridges of ch1 to ch3 can be driven as the resemblance 4-channels. For this reason, it is possible to drive the 2 Stepping Motors by ch1 to ch3 as long as the 2 motors don't move simultaneously. The selection of resemblance drive mode for ch1 to ch3 is set using serial function. (See the Driven Outputs for INPUT Terminal Table; p.14/32)

The 2 control input terminals of INPUT34 and INPUT45 drive the 3 H-bridges of ch3 to ch5. Use caution because it is impossible to drive all 3 H-bridges simultaneously.

## (2) The D/A Converter Settings of Constant-Voltage, Constant-Current, and Full-ON Mode

The ch1 to ch3 enable Constant-Voltage or Full-ON Driving, and the ch4 enables Constant-Voltage, Constant-Current, or Full-ON Driving, while the ch5 is Constant-Current Driving.

In the case of Full-ON mode for ch1 to ch3, input serial data of each Constant-Voltage setting D/A Converter (DAC12 and DAC3) to be full bits high.

In the ch4, as it set Constant-Voltage mode, input serial data of Constant-Current setting D/A Converter (DACI4) to be full bits high. As it set Constant-Current mode, input serial data of Constant-Voltage setting D/A Converter (DACV4) to be full bits high, while as it set Full-ON mode, input serial data of both D/A Converters to be full bits high. In the settings of Constant-Voltage or Full-ON mode, no need to connect the external resistance for output current detection in RNF4 pin.

The selection of drive mode for ch1 to ch4 is set using serial function. (See the serial settings of the drive mode in each channel; p.13/32 and p.15/32)

## (a) Constant-Voltage mode (ch1 to ch4)

Output high voltage;  $V_{VOHx}[V] = 8 \times V_{DACx}[V]$  ( $8 \times V_{DACx} \leq VM[V]$ ,  $x = 1, 2, 3, \text{ and } 4$ )  $\dots\dots(1)$

$V_{VOHx}[V] = VM[V]$  ( $8 \times V_{DACx} > VM[V]$ ,  $x = 1, 2, 3, \text{ and } 4$ )  $\dots\dots(2)$

D/A Converter setting value;  $8 \times V_{DACx}[V] = 1.5 \text{ to } 4.725$  ( $DACx = 6'b01\_0100 \text{ to } 6'b11\_1111$ ,  $x = 1, 2, 3, \text{ and } 4$ )

In the ch4, set DACI4 = 6'b11\_1111.

## (b) Constant-Current mode (ch4 and ch5)

Output current;  $I_{outx}[A] = V_{DACx}[V] \div (R_{METALx}[\Omega] + R_{RNFx}[\Omega])$  ( $x = 4 \text{ and } 5$ )  $\dots\dots(3)$

D/A Converter setting value;  $V_{DACx}[V] = 0.05 \text{ to } 0.315$  ( $DACx = 6'b00\_1010 \text{ to } 6'b11\_1111$ ,  $x = 4 \text{ and } 5$ )

$R_{METALx}$ ; metal impedance of BD6370GUL's inside (ch4;  $R_{METAL4}[\Omega] = 0.004$ (Typ.), ch5;  $R_{METAL5}[\Omega] = 0.022$ (Typ.))

$R_{RNFx}$ ; Resistance to connect RNFx pin for output current detection

In the ch4, set DACV4 = 6'b11\_1111.

## (c) Full-ON mode (ch1 to ch4)

D/A Converter setting value;  $DACx = 6'b11\_1111$  ( $x = 1, 2, 3, 4, \text{ and } 5$ )

4) Serial Input (BD6370GUL; STROBE, SCLK, and SDATA)

(1) Function Explanation

The BD6370GUL provides a 3-line serial interface for setting output modes and D/A converters.

SDATA is sent to the internal shift register during the STROBE low interval at the SCLK rising edge. Shift register data (Bit[B] to Bit[0]) is written to the IC's internal 12-bit memory at the STROBE rising edge, according to the addresses stored in Bit[E], Bit[D], and Bit[C]. The serial data input order is Bit[E] to Bit[0].

In the case of the resemblance drive mode (MODE13=1 and/or MODE23=1), input the serial data to be the same condition of DAC12 and DAC3.

Be cancelled power saving mode after turned on power supply VCC and VM. Serial settings are reset when the PS pin changes to Low-level control voltage, because of PS terminal combines power saving with serial reset function. Serial settings are also reset when the UVLO or TSD circuit operates.

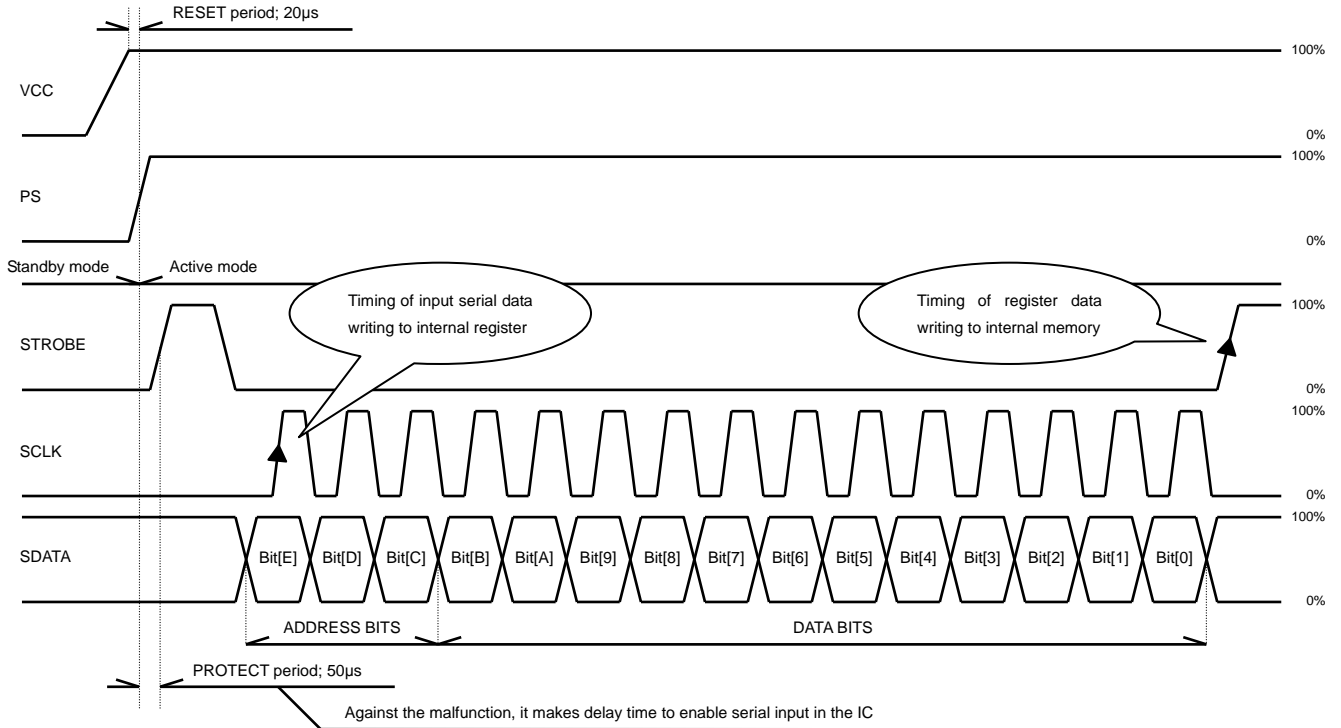

Fig.42 Sequence of Serial Control Input

(2) Serial Register Bit Map

Bit Map is consisted of 5 addresses and 60 data. It is the prohibited bit of MODExx input. Don't input the prohibited bit at all times. A low level should be input to the TEST bit at all times. A high signal may cause the IC to malfunction.

(a) The Prohibited Input of MODE Bit

(MODE45, MODE34, MODE23, MODE13) = (0, 0, 0, 1), (0, 0, 1, 0), (0, 0, 1, 1), (1, 0, 0, 1), (1, 0, 1, 0), (1, 0, 1, 1), (1, 1, 0, 0), (1, 1, 0, 1), (1, 1, 1, 0), (1, 1, 1, 1)

BD6370GUL Serial Register Bit Map

No.	ADDRESS BIT			DATA BIT											
	Bit[E]	Bit[D]	Bit[C]	Bit[B]	Bit[A]	Bit[9]	Bit[8]	Bit[7]	Bit[6]	Bit[5]	Bit[4]	Bit[3]	Bit[2]	Bit[1]	Bit[0]
00H	0	0	0	TEST	TEST	MODE45	MODE34	MODE23	MODE13	MODE3C	MODE3B	MODE3A	MODE12C	MODE12B	MODE12A
01H	0	0	1	DAC12[5]	DAC12[4]	DAC12[3]	DAC12[2]	DAC12[1]	DAC12[0]	MODE5B	MODE5A	MODE4D	MODE4C	MODE4B	MODE4A
02H	0	1	0	DAC5[5]	DAC5[4]	DAC5[3]	DAC5[2]	DAC5[1]	DAC5[0]	DAC3[5]	DAC3[4]	DAC3[3]	DAC3[2]	DAC3[1]	DAC3[0]
03H	0	1	1	DACV4[5]	DACV4[4]	DACV4[3]	DACV4[2]	DACV4[1]	DACV4[0]	DACI4[5]	DACI4[4]	DACI4[3]	DACI4[2]	DACI4[1]	DACI4[0]
04H	1	0	0	TEST	TEST	IN5B	IN5A	IN4B	IN4A	IN3B	IN3A	IN2B	IN2A	IN1B	IN1A

BD6370GUL Serial Register Bit Function

Bit Name	Function	Bit Name	Function
MODE13	OUT1A-OUT3A resemblance drive select	MODExA	Control input mode select ch1 to ch5 (x=1 to 5)
MODE23	OUT2A-OUT3B resemblance drive select	MODExB	Control input mode select ch1 to ch5 (x=1 to 5)
MODE34	INPUT34 terminal select ch3 or ch4	MODExC	Output drive select Constant-Voltage / Full-ON mode ch1 to ch3 (x=1 to 3)
MODE45	INPUT45 terminal select ch4 or ch5		
INxA	Control input mode select ch1 to ch5 (x=1 to 5)	MODExC	Output drive select Constant-Voltage /
INxB	Control input mode select ch1 to ch5 (x=1 to 5)	MODExD	Constant-Current / Full-ON mode ch4 (x=4)
TEST	TEST BIT (Low level input fixed)	DACx[y]	6Bit D/A Converter output select ch1 to ch5 (x=12 to 5, y=0 to 5)

5) Serial Register Data Bit Function (BD6370GUL)

(1) ADDRESS BIT [000] Function Explanation

No.	ADDRESS BIT			DATA BIT											
	Bit[E]	Bit[D]	Bit[C]	Bit[B]	Bit[A]	Bit[9]	Bit[8]	Bit[7]	Bit[6]	Bit[5]	Bit[4]	Bit[3]	Bit[2]	Bit[1]	Bit[0]
00H	0	0	0	TEST	TEST	MODE45	MODE34	MODE23	MODE13	MODE3C	MODE3B	MODE3A	MODE12C	MODE12B	MODE12A

(a) TEST; test bit for shipment inspection

A low signal should be input to the TEST bit at all times. A high signal may cause the IC to malfunction.

(b) MODE3C and MODE12C; output drive mode select for ch1, ch2, and ch3

Bit[5]	Bit[2]	drive mode for OUTPUT terminal			Note
MODE3C	MODE12C	ch3	ch2	ch1	
0	-	Full-ON	-	-	set DAC3=6'b11_1111
1	-	Constant-Voltage	-	-	
-	0	-	Full-ON	Full-ON	set DAC12=6'b11_1111
-	1	-	Constant-Voltage	Constant-Voltage	

(c) MODE3B, MODE3A, MODE12B, and MODE12A; control input mode select for ch3, ch2, and ch1, respectively

Refer to I/O Truth Table (p.21/32 to p.22/32) for the detail logic of MODE3B, MODE3A, MODE12B, and MODE12A.

(d) MODE45, MODE34; input terminal select for ch3, ch4, and ch5, and MODE23, MODE13; resemblance drive select for ch1, ch2, and ch3

Bit[9]	Bit[8]	Bit[7]	Bit[6]	driven outputs for INPUTx terminal				Note	
MODE45	MODE34	MODE23	MODE13	INPUT45	INPUT34	INPUT2	INPUT1	output terminal of OPEN mode	Ref No.
0	0	0	0	OUT4A-OUT4B	OUT3A-OUT3B	OUT2A-OUT2B	OUT1A-OUT1B	OUT5A, OUT5B	1
0	0	0	1	OUT4A-OUT4B	OUT3B	OUT2A-OUT2B	OUT1A-OUT3A	OUT1B, OUT5A, OUT5B	-
0	0	1	0	OUT4A-OUT4B	OUT3A	OUT2A-OUT3B	OUT1A-OUT1B	OUT2B, OUT5A, OUT5B	-
0	0	1	1	OUT4A-OUT4B	don't care	OUT2A-OUT3B	OUT1A-OUT3A	OUT1B, OUT2B, OUT5A, OUT5B	-
0	1	0	0	OUT5A-OUT5B	OUT4A-OUT4B	OUT2A-OUT2B	OUT1A-OUT1B	OUT3A, OUT3B	2
0	1	0	1	OUT5A-OUT5B	OUT4A-OUT4B	OUT2A-OUT2B	OUT1A-OUT3A	OUT1B, OUT3B	3
0	1	1	0	OUT5A-OUT5B	OUT4A-OUT4B	OUT2A-OUT3B	OUT1A-OUT1B	OUT2B, OUT3A	4
0	1	1	1	OUT5A-OUT5B	OUT4A-OUT4B	OUT2A-OUT3B	OUT1A-OUT3A	OUT1B, OUT2B	5
1	0	0	0	OUT5A-OUT5B	OUT3A-OUT3B	OUT2A-OUT2B	OUT1A-OUT1B	OUT4A, OUT4B	6
1	0	0	1	OUT5A-OUT5B	OUT3B	OUT2A-OUT2B	OUT1A-OUT3A	OUT1B, OUT4A, OUT4B	-
1	0	1	0	OUT5A-OUT5B	OUT3A	OUT2A-OUT3B	OUT1A-OUT1B	OUT2B, OUT4A, OUT4B	-
1	0	1	1	OUT5A-OUT5B	don't care	OUT2A-OUT3B	OUT1A-OUT3A	OUT1B, OUT2B, OUT4A, OUT4B	-
1	1	0	0	don't care	don't care	OUT2A-OUT2B	OUT1A-OUT1B	OUT3A, OUT3B, OUT4A, OUT4B, OUT5A, OUT5B	-
1	1	0	1	don't care	don't care	OUT2A-OUT2B	OUT1A-OUT3A	OUT1B, OUT3B, OUT4A, OUT4B, OUT5A, OUT5B	-
1	1	1	0	don't care	don't care	OUT2A-OUT3B	OUT1A-OUT1B	OUT2B, OUT3A, OUT4A, OUT4B, OUT5A, OUT5B	-
1	1	1	1	don't care	don't care	OUT2A-OUT3B	OUT1A-OUT3A	OUT1B, OUT2B, OUT4A, OUT4B, OUT5A, OUT5B	-

Gray lines are prohibition serial bit; don't input their bits at all times

**ATTENTION in the case of resemblance drive mode (MODE23=1 and/or MODE13=1)**

MODE3B, MODE3A, IN3B, and IN3A bits are "don't care". Because OUT1A-OUT3A is driven by MODE12B, MODE12A, IN1B, and IN1A bits, and INPUT1 terminal control. In the same condition, MODE12B, MODE12A, IN2B, and IN2A bits, and INPUT2 terminal drive OUT2A-OUT3B. And set the serial data as DAC12 = DAC3, if not, Output high voltage is different value between OUT1A and OUT3A, and/or OUT2A and OUT3B.

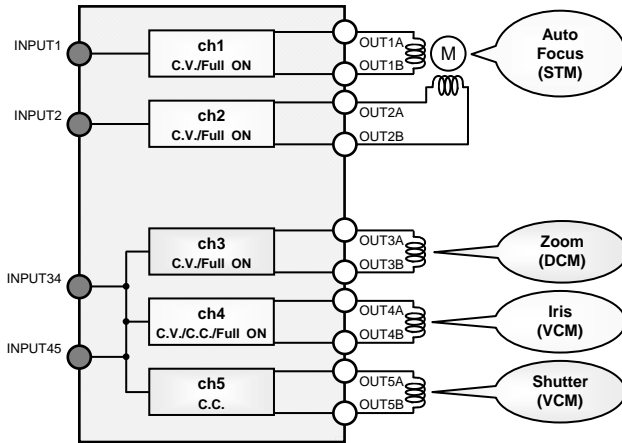

Fig.43 Example of Standard Model (ref No. 1, 2, and 6)

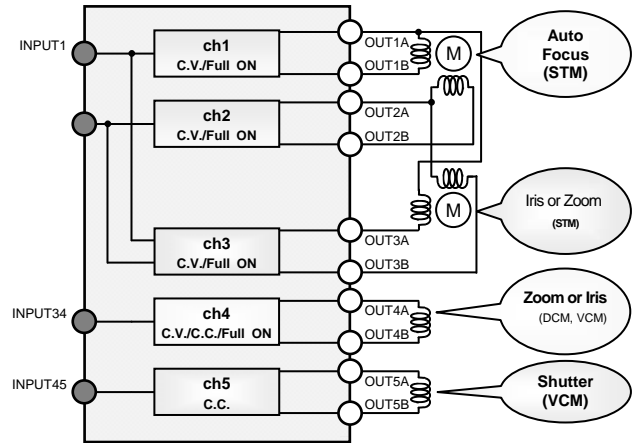

Fig.44 Example of High Performance Model (ref No.2 and 5)

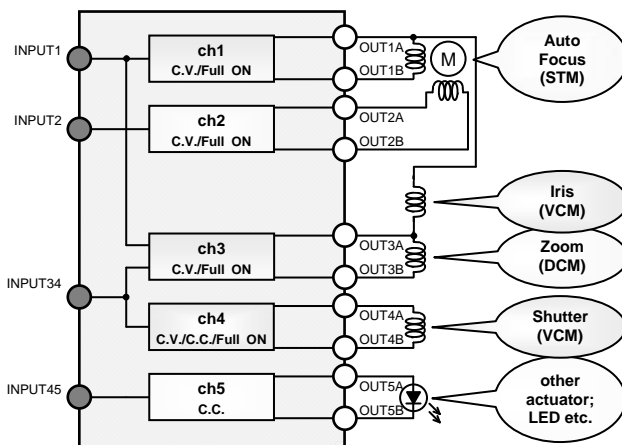

Fig.45 Example of Standard Model and 1 Actuator (ref No.3 and 6)

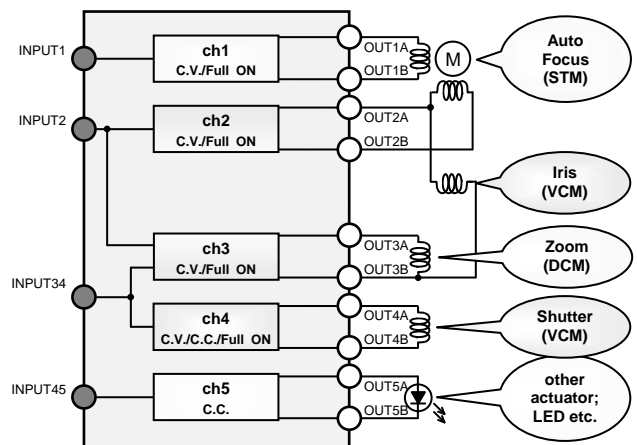

Fig.46 Example of Standard Model and 1 Actuator (ref No.4 and 6)

C.V.=Constant-Voltage drive mode, Full ON=Full-ON drive mode, and C.C.=Constant-Current drive mode  
 STM=Stepping Motor, DCM=DC Motor, and VCM=Voice Coil Motor

Examples of Applications above are typical. BD6370GUL is not limited to these applications.

(2) ADDRESS BIT [001] Function Explanation

No.	ADDRESS BIT			DATA BIT											
	Bit[E]	Bit[D]	Bit[C]	Bit[B]	Bit[A]	Bit[9]	Bit[8]	Bit[7]	Bit[6]	Bit[5]	Bit[4]	Bit[3]	Bit[2]	Bit[1]	Bit[0]
01H	0	0	1	DAC12[5]	DAC12[4]	DAC12[3]	DAC12[2]	DAC12[1]	DAC12[0]	MODE5B	MODE5A	MODE4D	MODE4C	MODE4B	MODE4A

(a) DAC12[5] to DAC12[0]; D/A Converter setting for output high voltage of Constant-Voltage mode in ch1 and ch2

Bit[B]	Bit[A]	Bit[9]	Bit[8]	Bit[7]	Bit[6]	DAC12 setting voltage; V <sub>DAC12</sub> [V]	Output high voltage; VVOH [V]
DAC12[5]	DAC12[4]	DAC12[3]	DAC12[2]	DAC12[1]	DAC12[0]		
0	1	0	1	0	0	0.188	1.500
0	1	0	1	0	1	0.197	1.575
0	1	0	1	1	0	0.206	1.650
0	1	0	1	1	1	0.216	1.725
0	1	1	0	0	0	0.225	1.800
0	1	1	0	0	1	0.234	1.875
0	1	1	0	1	0	0.244	1.950
0	1	1	0	1	1	0.253	2.025
0	1	1	1	0	0	0.263	2.100
0	1	1	1	0	1	0.272	2.175
0	1	1	1	1	0	0.281	2.250
0	1	1	1	1	1	0.291	2.325
1	0	0	0	0	0	0.300	2.400
1	0	0	0	0	1	0.309	2.475
1	0	0	0	1	0	0.319	2.550
1	0	0	0	1	1	0.328	2.625
1	0	0	1	0	0	0.338	2.700
1	0	0	1	0	1	0.347	2.775
1	0	0	1	1	0	0.356	2.850
1	0	0	1	1	1	0.366	2.925
1	0	1	0	0	0	0.375	3.000
1	0	1	0	0	1	0.384	3.075
1	0	1	0	1	0	0.394	3.150
1	0	1	0	1	1	0.403	3.225
1	0	1	1	0	0	0.413	3.300
1	0	1	1	0	1	0.422	3.375
1	0	1	1	1	0	0.431	3.450
1	0	1	1	1	1	0.441	3.525
1	1	0	0	0	0	0.450	3.600
1	1	0	0	0	1	0.459	3.675
1	1	0	0	1	0	0.469	3.750
1	1	0	0	1	1	0.478	3.825
1	1	0	1	0	0	0.488	3.900
1	1	0	1	0	1	0.497	3.975
1	1	0	1	1	0	0.506	4.050
1	1	0	1	1	1	0.516	4.125
1	1	1	0	0	0	0.525	4.200
1	1	1	0	0	1	0.534	4.275
1	1	1	0	1	0	0.544	4.350
1	1	1	0	1	1	0.553	4.425
1	1	1	1	0	0	0.563	4.500
1	1	1	1	0	1	0.572	4.575
1	1	1	1	1	0	0.581	4.650
1	1	1	1	1	1	0.591	4.725

(b) MODE4D and MODE4C; output drive mode select for ch4

Bit[3] MODE4D	Bit[2] MODE4C	drive mode for ch4	Note
0	0	Full-ON	set DACV4=DACI4=6'b11_1111, and RNF4 terminal to ground
0	1	Full-ON	set DACV4=DACI4=6'b11_1111, and RNF4 terminal to ground
1	0	Constant Voltage	set DACI4=6'b11_1111, and RNF4 terminal to ground
1	1	Constant Current	set DACV4=6'b11_1111, and RNF4 terminal with resistance to ground

(c) MODE5B, MODE5A, MODE4B, and MODE4A; control input mode select for ch5 and ch4, respectively  
Refer to I/O Truth Table (p.23/32) for the detail logic of MODE5B, MODE5A, MODE4B, and MODE4A.

(3) ADDRESS BIT [010] Function Explanation

No.	ADDRESS BIT			DATA BIT											
	Bit[E]	Bit[D]	Bit[C]	Bit[B]	Bit[A]	Bit[9]	Bit[8]	Bit[7]	Bit[6]	Bit[5]	Bit[4]	Bit[3]	Bit[2]	Bit[1]	Bit[0]
02H	0	1	0	DAC5[5]	DAC5[4]	DAC5[3]	DAC5[2]	DAC5[1]	DAC5[0]	DAC3[5]	DAC3[4]	DAC3[3]	DAC3[2]	DAC3[1]	DAC3[0]

(a) DAC5[5] to DAC5[0]; D/A Converter setting for output current (DAC5 setting voltage) of Constant-Current mode in ch5  
 As regards how to calculate the output current setting, refer to p.11/32 and p.24/32

Bit[B]	Bit[A]	Bit[9]	Bit[8]	Bit[7]	Bit[6]	DAC5 setting voltage; V <sub>DAC5</sub> [mV]	R <sub>RNF5</sub> =0.5Ω Output current [mA]	R <sub>RNF5</sub> =1.0Ω Output current [mA]
DAC5[5]	DAC5[4]	DAC5[3]	DAC5[2]	DAC5[1]	DAC5[0]			
0	0	1	0	1	0	50	96	49
0	0	1	0	1	1	55	105	54
0	0	1	1	0	0	60	115	59
0	0	1	1	0	1	65	125	64
0	0	1	1	1	0	70	134	68
0	0	1	1	1	1	75	144	73
0	1	0	0	0	0	80	153	78
0	1	0	0	0	1	85	163	83
0	1	0	0	1	0	90	172	88
0	1	0	0	1	1	95	182	93
0	1	0	1	0	0	100	192	98
0	1	0	1	0	1	105	201	103
0	1	0	1	1	0	110	211	108
0	1	0	1	1	1	115	220	113
0	1	1	0	0	0	120	230	117
0	1	1	0	0	1	125	239	122
0	1	1	0	1	0	130	249	127
0	1	1	0	1	1	135	259	132
0	1	1	1	0	0	140	268	137
0	1	1	1	0	1	145	278	142
0	1	1	1	1	0	150	287	147
0	1	1	1	1	1	155	297	152
1	0	0	0	0	0	160	307	157
1	0	0	0	0	1	165	316	161
1	0	0	0	1	0	170	326	166
1	0	0	0	1	1	175	336	171
1	0	0	1	0	0	180	345	176
1	0	0	1	0	1	185	355	181
1	0	0	1	1	0	190	364	186
1	0	0	1	1	1	195	374	191
1	0	1	0	0	0	200	383	196
1	0	1	0	0	1	205	393	201
1	0	1	0	1	0	210	Over Operating Condition	205
1	0	1	0	1	1	215		210
1	0	1	1	0	0	220		216
1	0	1	1	0	1	225		220
1	0	1	1	1	0	230		225
1	0	1	1	1	1	235		230
1	1	0	0	0	0	240		235
1	1	0	0	0	1	245		240
1	1	0	0	1	0	250		245
1	1	0	0	1	1	255		250
1	1	0	1	0	0	260		254
1	1	0	1	0	1	265		259
1	1	0	1	1	0	270		264
1	1	0	1	1	1	275		269
1	1	1	0	0	0	280		274
1	1	1	0	0	1	285		279
1	1	1	0	1	0	290		284
1	1	1	0	1	1	295		289
1	1	1	1	0	0	300		294
1	1	1	1	0	1	305		298
1	1	1	1	1	0	310	303	
1	1	1	1	1	1	315	308	



(b) DAC3[5] to DAC3[0]; D/A Converter setting for output high voltage of Constant-Voltage mode in ch3

Bit[5]	Bit[4]	Bit[3]	Bit[2]	Bit[1]	Bit[0]	DAC3 setting voltage; $V_{DAC3}$ [V]	Output high voltage; $V_{VOH}$ [V]
DAC3[5]	DAC3[4]	DAC3[3]	DAC3[2]	DAC3[1]	DAC3[0]		
0	1	0	1	0	0	0.188	1.500
0	1	0	1	0	1	0.197	1.575
0	1	0	1	1	0	0.206	1.650
0	1	0	1	1	1	0.216	1.725
0	1	1	0	0	0	0.225	1.800
0	1	1	0	0	1	0.234	1.875
0	1	1	0	1	0	0.244	1.950
0	1	1	0	1	1	0.253	2.025
0	1	1	1	0	0	0.263	2.100
0	1	1	1	0	1	0.272	2.175
0	1	1	1	1	0	0.281	2.250
0	1	1	1	1	1	0.291	2.325
1	0	0	0	0	0	0.300	2.400
1	0	0	0	0	1	0.309	2.475
1	0	0	0	1	0	0.319	2.550
1	0	0	0	1	1	0.328	2.625
1	0	0	1	0	0	0.338	2.700
1	0	0	1	0	1	0.347	2.775
1	0	0	1	1	0	0.356	2.850
1	0	0	1	1	1	0.366	2.925
1	0	1	0	0	0	0.375	3.000
1	0	1	0	0	1	0.384	3.075
1	0	1	0	1	0	0.394	3.150
1	0	1	0	1	1	0.403	3.225
1	0	1	1	0	0	0.413	3.300
1	0	1	1	0	1	0.422	3.375
1	0	1	1	1	0	0.431	3.450
1	0	1	1	1	1	0.441	3.525
1	1	0	0	0	0	0.450	3.600
1	1	0	0	0	1	0.459	3.675
1	1	0	0	1	0	0.469	3.750
1	1	0	0	1	1	0.478	3.825
1	1	0	1	0	0	0.488	3.900
1	1	0	1	0	1	0.497	3.975
1	1	0	1	1	0	0.506	4.050
1	1	0	1	1	1	0.516	4.125
1	1	1	0	0	0	0.525	4.200
1	1	1	0	0	1	0.534	4.275
1	1	1	0	1	0	0.544	4.350
1	1	1	0	1	1	0.553	4.425
1	1	1	1	0	0	0.563	4.500
1	1	1	1	0	1	0.572	4.575
1	1	1	1	1	0	0.581	4.650
1	1	1	1	1	1	0.591	4.725

## (4) ADDRESS BIT [011] Function Explanation

No.	ADDRESS BIT			DATA BIT											
	Bit[E]	Bit[D]	Bit[C]	Bit[B]	Bit[A]	Bit[9]	Bit[8]	Bit[7]	Bit[6]	Bit[5]	Bit[4]	Bit[3]	Bit[2]	Bit[1]	Bit[0]
03H	0	1	1	DACV4[5]	DACV4[4]	DACV4[3]	DACV4[2]	DACV4[1]	DACV4[0]	DACI4[5]	DACI4[4]	DACI4[3]	DACI4[2]	DACI4[1]	DACI4[0]

## (a) DACV4[5] to DACV4[0]; D/A Converter setting for output high voltage of Constant-Voltage mode in ch4

Bit[B]	Bit[A]	Bit[9]	Bit[8]	Bit[7]	Bit[6]	DACV4 setting voltage; $V_{DACV4}$ [V]	Output high voltage; $V_{VOH}$ [V]
DACV4[5]	DACV4[4]	DACV4[3]	DACV4[2]	DACV4[1]	DACV4[0]		
0	1	0	1	0	0	0.188	1.500
0	1	0	1	0	1	0.197	1.575
0	1	0	1	1	0	0.206	1.650
0	1	0	1	1	1	0.216	1.725
0	1	1	0	0	0	0.225	1.800
0	1	1	0	0	1	0.234	1.875
0	1	1	0	1	0	0.244	1.950
0	1	1	0	1	1	0.253	2.025
0	1	1	1	0	0	0.263	2.100
0	1	1	1	0	1	0.272	2.175
0	1	1	1	1	0	0.281	2.250
0	1	1	1	1	1	0.291	2.325
1	0	0	0	0	0	0.300	2.400
1	0	0	0	0	1	0.309	2.475
1	0	0	0	1	0	0.319	2.550
1	0	0	0	1	1	0.328	2.625
1	0	0	1	0	0	0.338	2.700
1	0	0	1	0	1	0.347	2.775
1	0	0	1	1	0	0.356	2.850
1	0	0	1	1	1	0.366	2.925
1	0	1	0	0	0	0.375	3.000
1	0	1	0	0	1	0.384	3.075
1	0	1	0	1	0	0.394	3.150
1	0	1	0	1	1	0.403	3.225
1	0	1	1	0	0	0.413	3.300
1	0	1	1	0	1	0.422	3.375
1	0	1	1	1	0	0.431	3.450
1	0	1	1	1	1	0.441	3.525
1	1	0	0	0	0	0.450	3.600
1	1	0	0	0	1	0.459	3.675
1	1	0	0	1	0	0.469	3.750
1	1	0	0	1	1	0.478	3.825
1	1	0	1	0	0	0.488	3.900
1	1	0	1	0	1	0.497	3.975
1	1	0	1	1	0	0.506	4.050
1	1	0	1	1	1	0.516	4.125
1	1	1	0	0	0	0.525	4.200
1	1	1	0	0	1	0.534	4.275
1	1	1	0	1	0	0.544	4.350
1	1	1	0	1	1	0.553	4.425
1	1	1	1	0	0	0.563	4.500
1	1	1	1	0	1	0.572	4.575
1	1	1	1	1	0	0.581	4.650
1	1	1	1	1	1	0.591	4.725

(b) DACI4[5] to DACI4[0]; D/A Converter setting for output current (DACI4 setting voltage) of Constant-Current mode in ch4  
As regards how to calculate the output current setting, refer to p.11/32 and p.24/32

Bit[5]	Bit[4]	Bit[3]	Bit[2]	Bit[1]	Bit[0]	DACI4 setting voltage; $V_{DACI4}$ [mV]	$R_{RNFI4}=0.5\Omega$ Output current [mA]	$R_{RNFI4}=1.0\Omega$ Output current [mA]
DACI4[5]	DACI4[4]	DACI4[3]	DACI4[2]	DACI4[1]	DACI4[0]			
0	0	1	0	1	0	50	99	50
0	0	1	0	1	1	55	109	55
0	0	1	1	0	0	60	119	60
0	0	1	1	0	1	65	129	65
0	0	1	1	1	0	70	139	70
0	0	1	1	1	1	75	149	75
0	1	0	0	0	0	80	159	80
0	1	0	0	0	1	85	169	85
0	1	0	0	1	0	90	179	90
0	1	0	0	1	1	95	188	95
0	1	0	1	0	0	100	198	100
0	1	0	1	0	1	105	208	105
0	1	0	1	1	0	110	218	110
0	1	0	1	1	1	115	228	115
0	1	1	0	0	0	120	238	120
0	1	1	0	0	1	125	248	125
0	1	1	0	1	0	130	258	129
0	1	1	0	1	1	135	268	134
0	1	1	1	0	0	140	278	139
0	1	1	1	0	1	145	288	144
0	1	1	1	1	0	150	298	149
0	1	1	1	1	1	155	308	154
1	0	0	0	0	0	160	317	159
1	0	0	0	0	1	165	327	164
1	0	0	0	1	0	170	337	169
1	0	0	0	1	1	175	347	174
1	0	0	1	0	0	180	357	179
1	0	0	1	0	1	185	367	184
1	0	0	1	1	0	190	377	189
1	0	0	1	1	1	195	387	194
1	0	1	0	0	0	200	397	199
1	0	1	0	0	1	205		204
1	0	1	0	1	0	210		209
1	0	1	0	1	1	215		214
1	0	1	1	0	0	220		219
1	0	1	1	0	1	225		224
1	0	1	1	1	0	230		229
1	0	1	1	1	1	235		234
1	1	0	0	0	0	240		239
1	1	0	0	0	1	245		244
1	1	0	0	1	0	250		249
1	1	0	0	1	1	255		254
1	1	0	1	0	0	260	Over Operating Condition	259
1	1	0	1	0	1	265		264
1	1	0	1	1	0	270		269
1	1	0	1	1	1	275		274
1	1	1	0	0	0	280		279
1	1	1	0	0	1	285		284
1	1	1	0	1	0	290		289
1	1	1	0	1	1	295		294
1	1	1	1	0	0	300		299
1	1	1	1	0	1	305		304
1	1	1	1	1	0	310		309
1	1	1	1	1	1	315		314

(5) ADDRESS BIT [100] Function Explanation

No.	ADDRESS BIT			DATA BIT											
	Bit[E]	Bit[D]	Bit[C]	Bit[B]	Bit[A]	Bit[9]	Bit[8]	Bit[7]	Bit[6]	Bit[5]	Bit[4]	Bit[3]	Bit[2]	Bit[1]	Bit[0]
04H	1	0	0	TEST	TEST	IN5B	IN5A	IN4B	IN4A	IN3B	IN3A	IN2B	IN2A	IN1B	IN1A

- (a) TEST; test bit for shipment inspection  
A low signal should be input to the TEST bit at all times. A high signal may cause the IC to malfunction.
- (b) IN5B to IN1A; control input mode select for ch1 to ch5, respectively  
Refer to I/O Truth Table (p.21/32 to p.23/32) for the detail logic of IN1A to IN5B.

## 6) I/O Truth Table (BD6370GUL)

## (1) I/O truth table for ch1 and ch2, in the case of MODE13=0, MODE23=0 (x=1 or 2)

Serial interface input bit				Terminal	Output terminal		MODE
MODE12B	MODE12A	INxB	INxA	INPUTx	OUTxA	OUTxB	
PWM Drive Mode by INPUTx terminal							
0	0	0	0	X	Z	Z	OFF
0	0	0	1	L	L	L	Brake
0	0	0	1	H	H	L	CW
0	0	1	0	L	L	L	Brake
0	0	1	0	H	L	H	CCW
0	0	1	1	X	L	L	Brake
PWM Drive Mode by INPUTx terminal							
0	1	0	0	X	Z	Z	OFF
0	1	0	1	L	H	L	CW
0	1	0	1	H	L	L	Brake
0	1	1	0	L	L	H	CCW
0	1	1	0	H	L	L	Brake
0	1	1	1	X	L	L	Brake
CW / CCW Drive Mode by INPUTx terminal							
1	0	X	0	X	Z	Z	OFF
1	0	0	1	L	L	H	CCW
1	0	0	1	H	H	L	CW
1	0	1	1	X	L	L	Brake
CW / CCW Drive Mode by INPUTx terminal							
1	1	X	0	X	Z	Z	OFF
1	1	0	1	L	H	L	CW
1	1	0	1	H	L	H	CCW
1	1	1	1	X	L	L	Brake

H; High level, L; Low level, Z; Hi impedance, X; Don't care

At CW, current flows from OUTxA to OUTxB. At CCW, current flows from OUTxB to OUTxA.

## (2) I/O truth table for ch3, in the case of MODE34=0, MODE13=0, and MODE23=0

Serial interface input bit				Terminal	Output terminal		MODE
MODE3B	MODE3A	IN3B	IN3A	INPUT34	OUT3A	OUT3B	
PWM Drive Mode by INPUT34 terminal							
0	0	0	0	X	Z	Z	OFF
0	0	0	1	L	L	L	Brake
0	0	0	1	H	H	L	CW
0	0	1	0	L	L	L	Brake
0	0	1	0	H	L	H	CCW
0	0	1	1	X	L	L	Brake
PWM Drive Mode by INPUT34 terminal							
0	1	0	0	X	Z	Z	OFF
0	1	0	1	L	H	L	CW
0	1	0	1	H	L	L	Brake
0	1	1	0	L	L	H	CCW
0	1	1	0	H	L	L	Brake
0	1	1	1	X	L	L	Brake
CW / CCW Drive Mode by INPUT34 terminal							
1	0	X	0	X	Z	Z	OFF
1	0	0	1	L	L	H	CCW
1	0	0	1	H	H	L	CW
1	0	1	1	X	L	L	Brake
CW / CCW Drive Mode by INPUT34 terminal							
1	1	X	0	X	Z	Z	OFF
1	1	0	1	L	H	L	CW
1	1	0	1	H	L	H	CCW
1	1	1	1	X	L	L	Brake

H; High level, L; Low level, Z; Hi impedance, X; Don't care

At CW, current flows from OUT3A to OUT3B. At CCW, current flows from OUT3B to OUT3A.

## (3) I/O truth table for ch1, ch3, in the case of MODE13=1 (OUT1A-OUT3A resemblance drive mode)

Serial interface input bit				Terminal INPUT1	Output terminal		MODE
MODE12B	MODE12A	IN1B	IN1A		OUT1A	OUT3A	
PWM Drive Mode by INPUT1 terminal							
0	0	0	0	X	Z	Z	OFF
0	0	0	1	L	L	L	Brake
0	0	0	1	H	H	L	CW
0	0	1	0	L	L	L	Brake
0	0	1	0	H	L	H	CCW
0	0	1	1	X	L	L	Brake
PWM Drive Mode by INPUT1 terminal							
0	1	0	0	X	Z	Z	OFF
0	1	0	1	L	H	L	CW
0	1	0	1	H	L	L	Brake
0	1	1	0	L	L	H	CCW
0	1	1	0	H	L	L	Brake
0	1	1	1	X	L	L	Brake
CW / CCW Drive Mode by INPUT1 terminal							
1	0	X	0	X	Z	Z	OFF
1	0	0	1	L	L	H	CCW
1	0	0	1	H	H	L	CW
1	0	1	1	X	L	L	Brake
CW / CCW Drive Mode by INPUT1 terminal							
1	1	X	0	X	Z	Z	OFF
1	1	0	1	L	H	L	CW
1	1	0	1	H	L	H	CCW
1	1	1	1	X	L	L	Brake

H; High level, L; Low level, Z; Hi impedance, X; Don't care, OUT1B; Hi impedance  
At CW, current flows from OUT1A to OUT3A. At CCW, current flows from OUT3A to OUT1A.

## (4) I/O truth table for ch2, ch3, in the case of MODE23=1 (OUT2A-OUT3B resemblance drive mode)

Serial interface input bit				Terminal INPUT2	Output terminal		MODE
MODE12B	MODE12A	IN2B	IN2A		OUT2A	OUT3B	
PWM Drive Mode by INPUT2 terminal							
0	0	0	0	X	Z	Z	OFF
0	0	0	1	L	L	L	Brake
0	0	0	1	H	H	L	CW
0	0	1	0	L	L	L	Brake
0	0	1	0	H	L	H	CCW
0	0	1	1	X	L	L	Brake
PWM Drive Mode by INPUT2 terminal							
0	1	0	0	X	Z	Z	OFF
0	1	0	1	L	H	L	CW
0	1	0	1	H	L	L	Brake
0	1	1	0	L	L	H	CCW
0	1	1	0	H	L	L	Brake
0	1	1	1	X	L	L	Brake
CW / CCW Drive Mode by INPUT2 terminal							
1	0	X	0	X	Z	Z	OFF
1	0	0	1	L	L	H	CCW
1	0	0	1	H	H	L	CW
1	0	1	1	X	L	L	Brake
CW / CCW Drive Mode by INPUT2 terminal							
1	1	X	0	X	Z	Z	OFF
1	1	0	1	L	H	L	CW
1	1	0	1	H	L	H	CCW
1	1	1	1	X	L	L	Brake

H; High level, L; Low level, Z; Hi impedance, X; Don't care, OUT2B; Hi impedance  
At CW, current flows from OUT2A to OUT3B. At CCW, current flows from OUT3B to OUT2A.

**ATTENTION in the case of resemblance drive mode (MODE23=1 and/or MODE13=1)**

MODE3B, MODE3A, IN3B, and IN3A bits are "don't care". Because OUT1A-OUT3A is driven by MODE12B, MODE12A, IN1B, and IN1A bits, and INPUT1 terminal control. In the same condition, MODE12B, MODE12A, IN2B, and IN2A bits, and INPUT2 terminal drive OUT2A-OUT3B. And set the serial data as DAC12 = DAC3, if not, Output high voltage is different value between OUT1A and OUT3A, and/or OUT2A and OUT3B.

(5) I/O truth table for ch4, in the case of MODE45=0 (if MODE34=0, then x=45, else then x=34)

Serial interface input bit				Terminal	Output terminal		MODE
MODE4B	MODE4A	IN4B	IN4A	INPUTx	OUT4A	OUT4B	
PWM Drive Mode by INPUTx terminal							
0	0	0	0	X	Z	Z	OFF
0	0	0	1	L	L	L	Brake
0	0	0	1	H	H	L	CW
0	0	1	0	L	L	L	Brake
0	0	1	0	H	L	H	CCW
0	0	1	1	X	L	L	Brake
PWM Drive Mode by INPUTx terminal							
0	1	0	0	X	Z	Z	OFF
0	1	0	1	L	H	L	CW
0	1	0	1	H	L	L	Brake
0	1	1	0	L	L	H	CCW
0	1	1	0	H	L	L	Brake
0	1	1	1	X	L	L	Brake
CW / CCW Drive Mode by INPUTx terminal							
1	0	X	0	X	Z	Z	OFF
1	0	0	1	L	L	H	CCW
1	0	0	1	H	H	L	CW
1	0	1	1	X	L	L	Brake
CW / CCW Drive Mode by INPUTx terminal							
1	1	X	0	X	Z	Z	OFF
1	1	0	1	L	H	L	CW
1	1	0	1	H	L	H	CCW
1	1	1	1	X	L	L	Brake

H; High level, L; Low level, Z; Hi impedance, X; Don't care

At CW, current flows from OUT4A to OUT4B. At CCW, current flows from OUT4B to OUT4A.

(6) I/O truth table for ch5, in the case of MODE45=1, MODE34=0 (or MODE45=0, MODE34=1)

Serial interface input bit				Terminal	Output terminal		MODE
MODE5B	MODE5A	IN5B	IN5A	INPUT45	OUT5A	OUT5B	
PWM Drive Mode by INPUT45 terminal							
0	0	0	0	X	Z	Z	OFF
0	0	0	1	L	L	L	Brake
0	0	0	1	H	H	L	CW
0	0	1	0	L	L	L	Brake
0	0	1	0	H	L	H	CCW
0	0	1	1	X	L	L	Brake
PWM Drive Mode by INPUT45 terminal							
0	1	0	0	X	Z	Z	OFF
0	1	0	1	L	H	L	CW
0	1	0	1	H	L	L	Brake
0	1	1	0	L	L	H	CCW
0	1	1	0	H	L	L	Brake
0	1	1	1	X	L	L	Brake
CW / CCW Drive Mode by INPUT45 terminal							
1	0	X	0	X	Z	Z	OFF
1	0	0	1	L	L	H	CCW
1	0	0	1	H	H	L	CW
1	0	1	1	X	L	L	Brake
CW / CCW Drive Mode by INPUT45 terminal							
1	1	X	0	X	Z	Z	OFF
1	1	0	1	L	H	L	CW
1	1	0	1	H	L	H	CCW
1	1	1	1	X	L	L	Brake

H; High level, L; Low level, Z; Hi impedance, X; Don't care

At CW, current flows from OUT5A to OUT5B. At CCW, current flows from OUT5B to OUT5A.

7) The More Precise Constant-Current Settings (BD6370GUL)

Regarding Constant-Current Drive blocks (ch4 and ch5), there is the metal impedance of each RNF in BD6370GUL inside: 4mΩ (Typ.) and 22mΩ (Typ.), respectively. Then the metal impedances and the board patterning impedances of RNF4 and RNF5 lines considered, set each D/A Converter to drive the actuator in the more precise constant current.

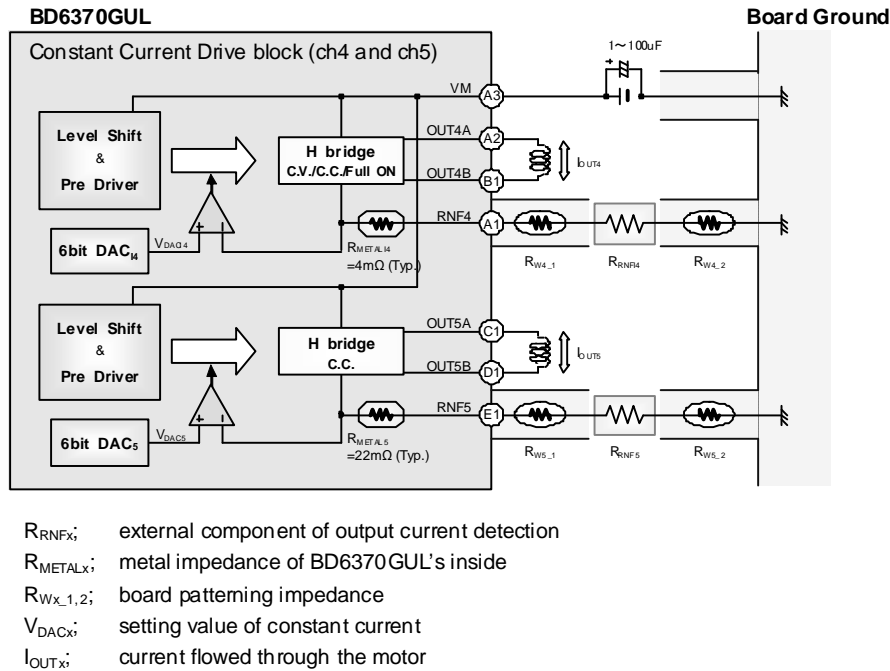

Fig.47 Metal Impedance and Board Patterning Impedance of Constant-Current block

The more correct D/A Converter settings of Constant-Current H-bridge (ch4 and ch5)

Output current value;  $I_{OUTx}[A] = V_{DACx}[V] \div (R_{RNFx}[\Omega] + R_{METALx}[\Omega] + R_{WX_{1}}[\Omega] + R_{WX_{2}}[\Omega])$

(ex.) If there are  $V_{DACx}=0.1[V]$ ,  $R_{RNFx}=0.5[\Omega]$ , and  $R_{WX_{1}} + R_{WX_{2}}=0[\Omega]$  (the ideal patterning condition), then

Output current value (ch4);  $I_{OUT4}[A] = 0.1[V] \div (0.5[\Omega] + 0.004[\Omega] + 0[\Omega]) = \mathbf{0.198}$

Output current value (ch5);  $I_{OUT5}[A] = 0.1[V] \div (0.5[\Omega] + 0.022[\Omega] + 0[\Omega]) = \mathbf{0.191}$

Else if there are  $V_{DACx}=0.1[V]$ ,  $R_{RNFx}= 0.5[\Omega]$ , and  $R_{WX_{1}} + R_{WX_{2}}=\mathbf{0.05}[\Omega]$  (the more closely real patterning condition; the value is different to the patterning), then

Output current value (ch4);  $I_{OUT4}[A] = 0.1[V] \div (0.5[\Omega] + 0.004[\Omega] + 0.05[\Omega]) = \mathbf{0.181}$

Output current value (ch5);  $I_{OUT5}[A] = 0.1[V] \div (0.5[\Omega] + 0.022[\Omega] + 0.05[\Omega]) = \mathbf{0.175}$



8) Application control sequences (BD6370GUL)  
 (1) Stepping Motor drive controlled by 2 phases mode

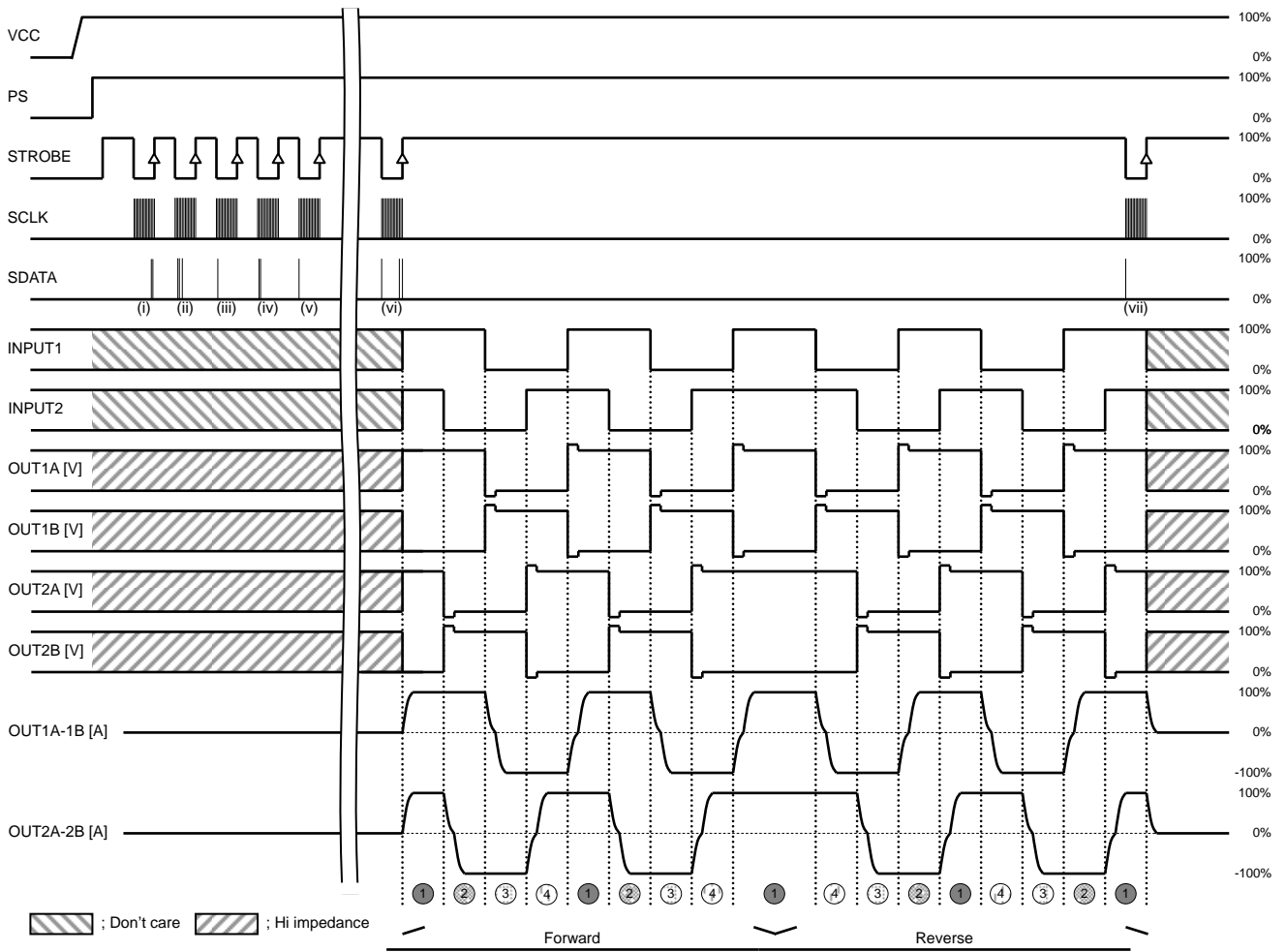

Fig.48 Timing Chart of Stepping Motor Drive

Sequence of Stepping Motor Drive

Serial interface input bit						Terminal		Output terminal				MODE		
MODE 12B	MODE 12A	IN2B	IN2A	IN1B	IN1A	INPUT1	INPUT2	OUT1A	OUT1B	OUT2A	OUT2B	ch1	ch2	Position
<b>Control standby</b>														
1	0	0	0	0	0	X	X	Z	Z	Z	Z			
<b>Start 2 phase mode driving</b>														
1	0	0	1	0	1	H	H	H	L	H	L	CW	CW	1
1	0	0	1	0	1	H	L	H	L	L	H	CW	CCW	2
1	0	0	1	0	1	L	L	L	H	L	H	CCW	CCW	3
1	0	0	1	0	1	L	H	L	H	H	L	CCW	CW	4
1	0	0	1	0	1	H	H	H	L	H	L	CW	CW	1
1	0	0	1	0	1	H	H	H	L	H	L	CW	CW	1
1	0	0	1	0	1	L	H	L	H	H	L	CCW	CW	4
1	0	0	1	0	1	L	L	L	H	L	H	CCW	CCW	3
1	0	0	1	0	1	H	L	H	L	L	H	CW	CCW	2
1	0	0	1	0	1	H	H	H	L	H	L	CW	CW	1
<b>End timing (control standby)</b>														
1	0	0	0	0	0	X	X	Z	Z	Z	Z			

H; High level, L; Low level, Z; Hi impedance, X; Don't care  
 At CW, current flows from OUTxA to OUTxB. At CCW, current flows from OUTxB to OUTxA.  
 At Forward; position up from "1" to "4". At Reverse; position down from "4" to "1".

In Fig.49, it shows minimum step angle, and the relation between size and direction of the current to motor.

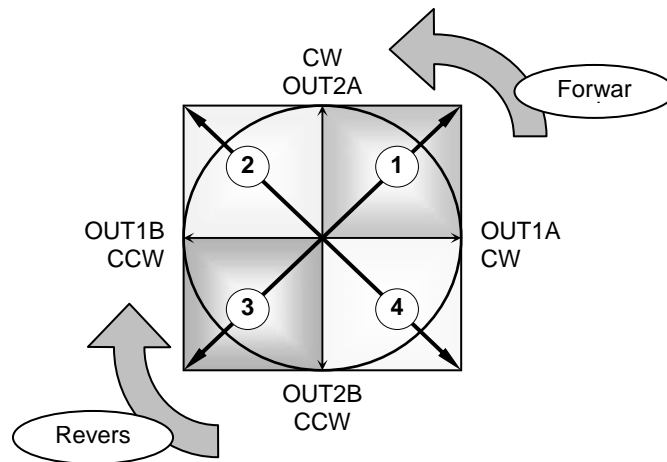

Fig.49 Torque Vector of 2 Phases Mode

Serial Control Input from Initial Set Up (i) to End Timing (vii)

No.	ADDRESS BIT			DATA BIT											
	Bit[E]	Bit[D]	Bit[C]	Bit[B]	Bit[A]	Bit[9]	Bit[8]	Bit[7]	Bit[6]	Bit[5]	Bit[4]	Bit[3]	Bit[2]	Bit[1]	Bit[0]
<b>Initial set up</b>															
<b>(i) ADDRESS BIT [000]; set ch1 and ch2; Constant-Voltage drive mode</b>															
00H	0	0	0	TEST	TEST	MODE45	MODE34	MODE23	MODE13	MODE3C	MODE3B	MODE3A	MODE12C	MODE12B	MODE12A
				0	0	0	0	0	0	0	0	0	1	1	0
<b>(ii) ADDRESS BIT [001]; set Output high voltage=3.0V for ch1 and ch2</b>															
01H	0	0	1	DAC12[5]	DAC12[4]	DAC12[3]	DAC12[2]	DAC12[1]	DAC12[0]	MODE5B	MODE5A	MODE4D	MODE4C	MODE4B	MODE4A
				1	0	1	0	0	0	0	0	0	0	0	0
<b>(iii) ADDRESS BIT [010]; in this case, don't care</b>															
02H	0	1	0	DAC5[5]	DAC5[4]	DAC5[3]	DAC5[2]	DAC5[1]	DAC5[0]	DAC3[5]	DAC3[4]	DAC3[3]	DAC3[2]	DAC3[1]	DAC3[0]
				0	0	0	0	0	0	0	0	0	0	0	0
<b>(iv) ADDRESS BIT [011]; in this case, don't care</b>															
03H	0	1	1	DACV4[5]	DACV4[4]	DACV4[3]	DACV4[2]	DACV4[1]	DACV4[0]	DACI4[5]	DACI4[4]	DACI4[3]	DACI4[2]	DACI4[1]	DACI4[0]
				0	0	0	0	0	0	0	0	0	0	0	0
<b>(v) ADDRESS BIT [100]; set control standby mode</b>															
04H	1	0	0	TEST	TEST	IN5B	IN5A	IN4B	IN4A	IN3B	IN3A	IN2B	IN2A	IN1B	IN1A
				0	0	0	0	0	0	0	0	0	0	0	0
<b>Start timing</b>															
<b>(vi) ADDRESS BIT [100]</b>															
04H	1	0	0	TEST	TEST	IN5B	IN5A	IN4B	IN4A	IN3B	IN3A	IN2B	IN2A	IN1B	IN1A
				0	0	0	0	0	0	0	0	0	1	0	1
<b>End timing</b>															
<b>(vii) ADDRESS BIT [100]</b>															
04H	1	0	0	TEST	TEST	IN5B	IN5A	IN4B	IN4A	IN3B	IN3A	IN2B	IN2A	IN1B	IN1A
				0	0	0	0	0	0	0	0	0	0	0	0

The above Sequence is one example. BD6370GUL is not limited to this sequence.

### ●BD6758MWV and BD6758KN Function Explanation

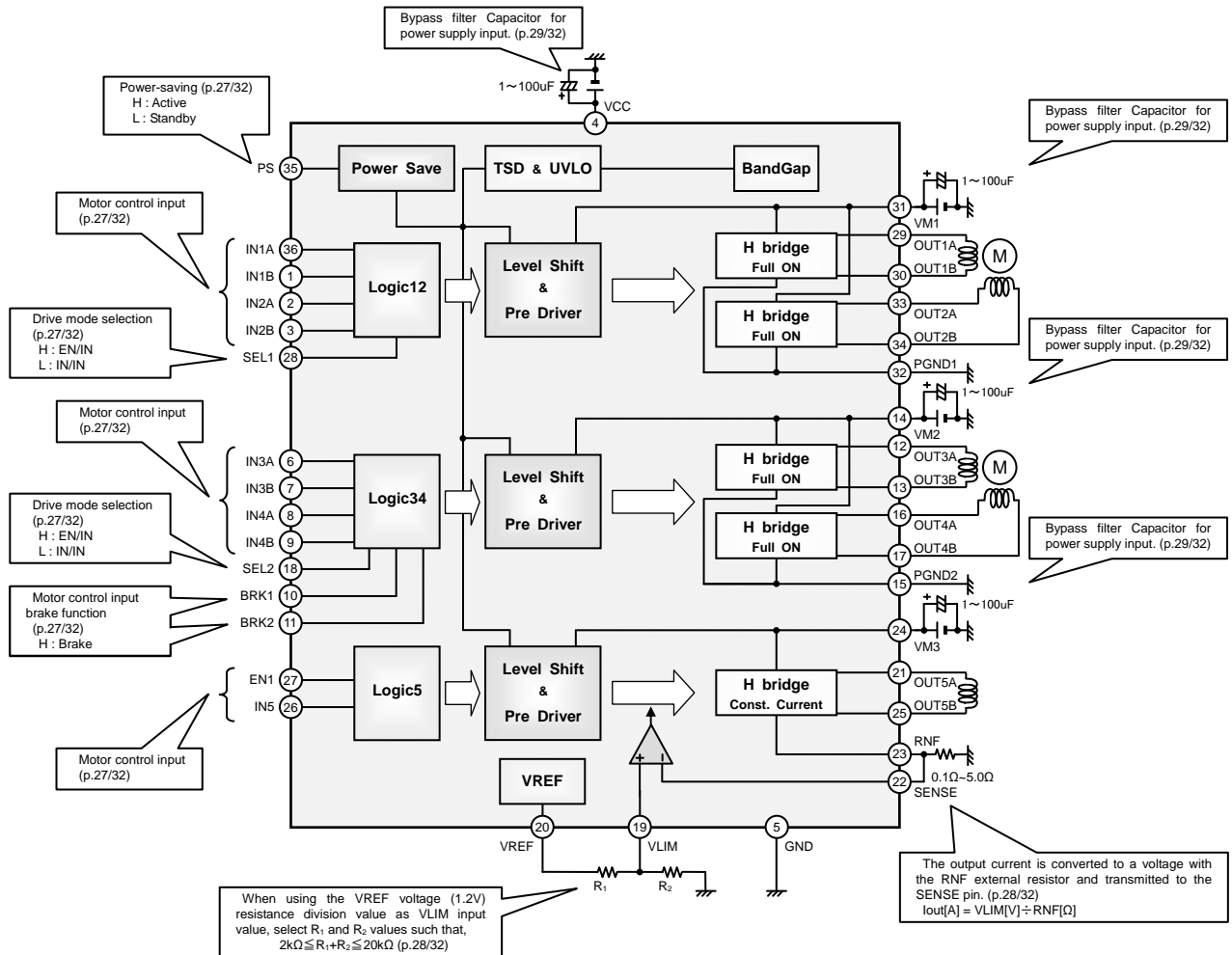

Fig.50 BD6758MWV / KN Application Circuit Diagram

#### 1) Power-saving function (BD6758MWV / KN)

When Low-level voltage is applied to PS pin, the IC will be turned off internally and the circuit current will be 0μA (Typ.). During operating mode, PS pin should be High-level. (See the Electrical Characteristics; p.6/32)

#### 2) Control input (BD6758MWV / KN)

##### (1) INxA, INxB, EN1 and IN5 pins

These pins are used to program and control the motor drive modes. (See the Electrical Characteristics; p.6/32 and I/O Truth Table; p.28/32)

##### (2) SELx pins

When the Low-level voltage is applied to the SEL pin, the I/O logic can be set to EN/IN mode. However, when the High-level voltage is applied, the I/O logic can be set to IN/IN mode. (See the Electrical Characteristics; p.6/32 and I/O Truth Table; p.28/32)

##### (3) BRKx pins

Applying the High-level voltage to the BRKx pin will set the brake mode. (See the Electrical Characteristics; p.6/32 and I/O Truth Table; p.28/32)

#### 3) H-bridge (BD6758MWV / KN)

The 5-channel H-bridges can be controlled independently. For this reason, it is possible to drive the H-bridges simultaneously, as long as the package thermal tolerances are not exceeded.

The H-bridge output transistors of BD6758MWV and BD6758KN are Power CMOS Drivers. The total H-bridge ON-Resistance on the high and low sides varies with the VM voltage. The system must be designed so that the maximum H-bridge current for each channel is 800mA or below. (See the Operating Conditions; p.2/32)

4) Drive system of Linear Constant-Current H-bridge (BD6758MWV / KN: ch5)

BD6758MWV / KN (ch5) enable Linear Constant-Current Driving.

(1) Reference voltage output (with a tolerance of ±3%)

The VREF pin outputs 1.2V, based on the internal reference voltage. The output current of the Constant-Current Drive block is controllable by connecting external resistance to the VREF pin of the IC and applying a voltage divided by the resistor to the output current setting pins (VLIM pin). It is recommended to set the external resistance to 2kΩ or above in consideration of the current capacity of the VREF pin, and 20kΩ or below in order to minimize the fluctuation of the set value caused by the base current of the internal transistor of the IC.

(2) Output current detection and current settings

By connecting external resistor (0.1Ω to 5.0Ω) to the RNF pin of the IC, the motor drive current will be converted into voltage in order to be detected. The output current is kept constant by shorting the RNF and SENSE pins and comparing the voltage with the VLIM voltage. To perform output current settings more precisely, trim the external RNF resistance if needed, and supply a precise voltage externally to the VLIM pin of the IC. In that case, open the VREF pin.

$$\text{Output current value} = \frac{\text{VLIM[V]}}{\text{RNF}[\Omega]}$$

The output current is 400mA±3% if 0.2V is applied to the VLIM pin and a 0.5Ω resistor is connected externally to the RNF pin.

If the VLIM pin is shorted to the VCC pin (or the same voltage level as the VCC is applied) and the SENSE and RNF pins are shorted to the ground, this channel can be used as a Full-ON Drive H-bridge like the other four channels of BD6758KN.

5) I/O truth table (BD6758MWV / KN)

BD6758MWV / KN Full-ON Driver ch1 and ch2 I/O Truth Table

Drive mode	INPUT			OUTPUT		Output mode
	SEL1	INxA	INxB	OUTxA	OUTxB	
EN/IN	L	H	X	Z	Z	Standby
		L	L	H	L	CW
		L	H	L	H	CCW
IN/IN	H	L	L	Z	Z	Standby
		H	L	H	L	CW
		L	H	L	H	CCW
		H	H	L	L	Brake

L: Low, H: High, X: Don't care, Z: High impedance

At CW, current flows from OUTA to OUTB. At CCW, current flows from OUTB to OUTA.

BD6758MWV / KN Full-ON Driver ch3 and ch4 I/O Truth Table

Drive mode	INPUT				OUTPUT		Output mode
	SEL2	INxA	INxB	BRKx	OUTxA	OUTxB	
EN/IN	L	H	X	X	Z	Z	Standby
		L	L	L	H	L	CW
		L	H	L	L	H	CCW
		L	X	H	L	L	Brake
IN/IN	H	L	L	X	Z	Z	Standby
		H	L	X	H	L	CW
		L	H	X	L	H	CCW
		H	H	X	L	L	Brake

L: Low, H: High, X: Don't care, Z: High impedance

At CW, current flows from OUTA to OUTB. At CCW, current flows from OUTB to OUTA.

BD6758MWV / KN Linear Constant-Current Driver ch5 I/O Truth Table

Drive mode	INPUT		OUTPUT		Output mode
	EN1	IN5	OUT5A	OUT5B	
EN/IN	H	X	Z	Z	Standby
	L	L	H	L	CW
	L	H	L	H	CCW

L: Low, H: High, X: Don't care, Z: High impedance

At CW, current flows from OUTA to OUTB. At CCW, current flows from OUTB to OUTA.

● I/O Circuit Diagram

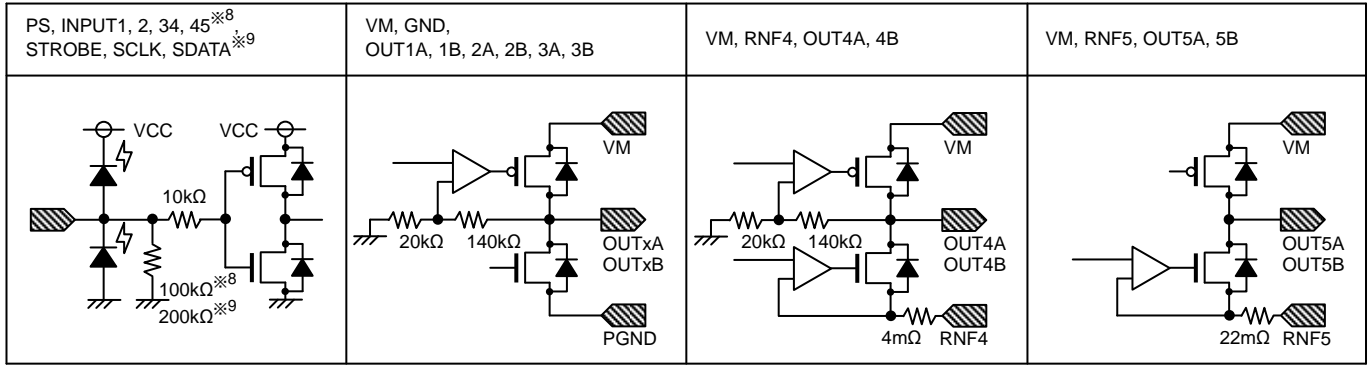

Fig.51 BD6370GUL I/O Circuit Diagram (Resistance values are typical ones)

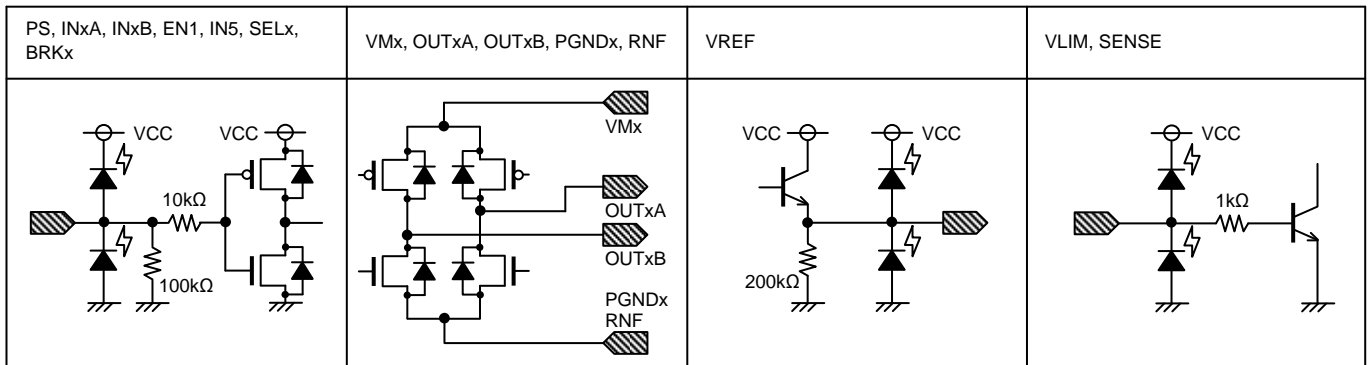

Fig.52 BD6758MWV / KN I/O Circuit Diagram (Resistance values are typical ones)

● Notes for use

- 1) Absolute maximum ratings  
Use of the IC in excess of absolute maximum ratings such as the applied voltage or operating temperature range may result in IC damage. Assumptions should not be made regarding the state of the IC (short mode or open mode) when such damage is suffered. The implementation of a physical safety measure such as a fuse should be considered when use of the IC in a special mode where the absolute maximum ratings may be exceeded is anticipated.
- 2) Storage temperature range  
As long as the IC is kept within this range, there should be no problems in the IC's performance. Conversely, extreme temperature changes may result in poor IC performance, even if the changes are within the above range.
- 3) Power supply pins and lines  
None of the VM line for the H-bridges is internally connected to the VCC power supply line, which is only for the control logic or analog circuit. Therefore, the VM and VCC lines can be driven at different voltages. Although these lines can be connected to a common power supply, do not open the power supply pin but connect it to the power supply externally.  
Regenerated current may flow as a result of the motor's back electromotive force. Insert capacitors between the power supply and ground pins to serve as a route for regenerated current. Determine the capacitance in full consideration of all the characteristics of the electrolytic capacitor, because the electrolytic capacitor may lose some capacitance at low temperatures. If the connected power supply does not have sufficient current absorption capacity, regenerative current will cause the voltage on the power supply line to rise, which combined with the product and its peripheral circuitry may exceed the absolute maximum ratings. It is recommended to implement a physical safety measure such as the insertion of a voltage clamp diode between the power supply and ground pins.  
For this IC with several power supplies and a part consists of the CMOS block, it is possible that rush current may flow instantaneously due to the internal powering sequence and delays, and to the unstable internal logic, respectively. Therefore, give special consideration to power coupling capacitance, width of power and ground wirings, and routing of wiring.
- 4) Ground pins and lines  
Ensure a minimum GND pin potential in all operating conditions. Make sure that no pins are at a voltage below the GND at any time, regardless of whether it is a transient signal or not.  
When using both small signal GND and large current MGND patterns, it is recommended to isolate the two ground patterns, placing a single ground point at the application's reference point so that the pattern wiring resistance and voltage variations caused by large currents do not cause variations in the small signal ground voltage. Be careful not to change the GND wiring pattern of any external components, either.  
The power supply and ground lines must be as short and thick as possible to reduce line impedance.
- 5) Thermal design  
Use a thermal design that allows for a sufficient margin in light of the power dissipation (Pd) in actual operating conditions.

- 6) Pin short and wrong direction assembly of the device  
Use caution when positioning the IC for mounting on printed circuit boards. The IC may be damaged if there is any connection error or if positive and ground power supply terminals are reversed. The IC may also be damaged if pins are shorted together or are shorted to other circuit's power lines.
- 7) Actions in strong magnetic field  
Use caution when using the IC in the presence of a strong magnetic field as doing so may cause the IC to malfunction.
- 8) ASO  
When using the IC, set the output transistor for the motor so that it does not exceed absolute maximum ratings or ASO.
- 9) Thermal shutdown circuit  
If the junction temperature ( $T_{jmax}$ ) reaches 175°C, the TSD circuit will operate, and the coil output circuit of the motor will open. There is a temperature hysteresis of approximately 25°C (BD6373GW and BD6873KN Typ.) and 25°C (BD6753KV Typ.). The TSD circuit is designed only to shut off the IC in order to prevent runaway thermal operation. It is not designed to protect the IC or guarantee its operation. The performance of the IC's characteristics is not guaranteed and it is recommended that the device is replaced after the TSD is activated.
- 10) Serial data input  
In the BD6370GUL, SDATA input string start with MSB first. A low level should be input to the TEST bit at all times. A high signal may cause the IC to malfunction. The serial settings are reset during standby mode operation and whenever the UVLO or TSD circuits are operating.  
It is the prohibited bit of MODExx input. Don't input the prohibited bit at all times. (See the Serial Register Bit Map; p.12/32)  
In the case of the resemblance drive mode (MODE13=1 and/or MODE23=1), MODE3B, MODE3A, IN3B, and IN3A bits are "don't care". Because OUT1A-OUT3A is driven by MODE12B, MODE12A, IN1B, and IN1A bits, and INPUT1 terminal control. In the same condition, MODE12B, MODE12A, IN2B, and IN2A bits, and INPUT2 terminal drive OUT2A-OUT3B. And set the serial data as DAC12 = DAC3, if not, Output high voltage is different value between OUT1A and OUT3A, and/or OUT2A and OUT3B. In the case of Full-ON mode for ch1 to ch3, input serial data of each Constant-Voltage setting D/A Converter (DAC12 and DAC3) to be full bits high.  
In the ch4, as it set Constant-Voltage mode, input serial data of Constant-Current setting D/A Converter (DACI4) to be full bits high. As it set Constant-Current mode, input serial data of Constant-Voltage setting D/A Converter (DACV4) to be full bits high, while as it set Full-ON mode, input serial data of both D/A Converters to be full bits high. In the settings of Constant-Voltage or Full-ON mode, no need to connect the external resistance for output current detection in RNF4 pin.
- 11) Power saving terminal  
Be cancelled power saving mode after turned on power supply VCC and VM, because of PS terminal combines power saving with serial reset function. If the case of power saving terminal always shorted power supply terminal, reset function may not be well, and it may cause the IC to malfunction.
- 12) Testing on application board  
When testing the IC on an application board, connecting a capacitor to a pin with low impedance subjects the IC to stress. Always discharge capacitors after each process or step. Always turn the IC's power supply off before connecting it to, or removing it from a jig or fixture, during the inspection process. Ground the IC during assembly steps as an antistatic measure. Use similar precaution when transporting and storing the IC.
- 13) Application example  
The application circuit is recommended for use. Make sure to confirm the adequacy of the characteristics. When using the circuit with changes to the external circuit constants, make sure to leave an adequate margin for external components including static and transitional characteristics as well as dispersion of the IC.
- 14) Regarding input pin of the IC  
This monolithic IC contains P<sup>+</sup> isolation and P substrate layers between adjacent elements to keep them isolated. P-N junctions are formed at the intersection of these P layers with the N layers of other elements, creating a parasitic diode or transistor. For example, the relation between each potential is as follows:  
When GND > Pin A, the P-N junction operates as a parasitic diode.  
When GND > Pin B, the P-N junction operates as a parasitic diode and transistor.  
Parasitic elements can occur inevitably in the structure of the IC. The operation of parasitic elements can result in mutual interference among circuits, operational faults, or physical damage. Accordingly, methods by which parasitic elements operate, such as applying a voltage that is lower than the GND (P substrate) voltage to an input pin, should not be used.

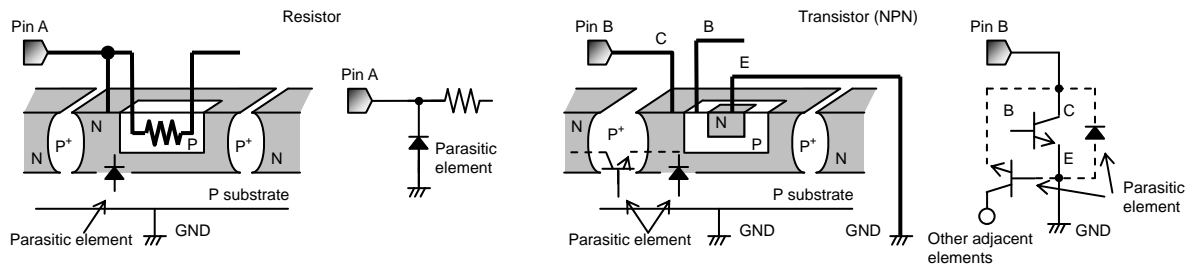

Fig.53 Example of Simple IC Architecture

● Ordering part number

B	D
---	---

6	3	7	0
---	---	---	---

G	U	L
---	---	---

-	E	2
---	---	---

Part No.

Part No.  
 6370 :C.V./F.ON 3ch  
 +C.V./C.C./F.ON 1ch  
 +C.C. 1ch  
 6758 :F.ON 4ch+C.C. 1ch

Package

GUL : VCSP50L2  
 MWV : UQFN036V5050  
 KN : VQFN36

Packaging and forming specification  
 E2: Embossed tape and reel

VCSP50L2 (BD6360GUL)

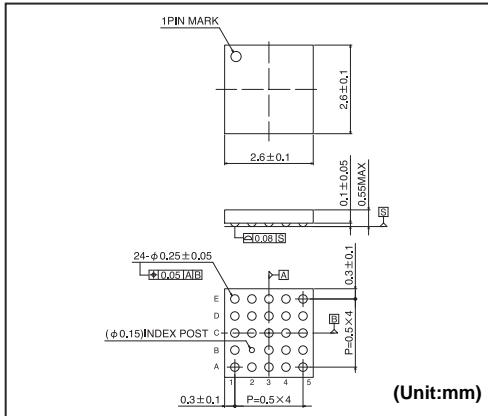

<Tape and Reel information>

Tape	Embossed carrier tape
Quantity	3000pcs
Direction of feed	E2 ( The direction is the 1pin of product is at the upper left when you hold reel on the left hand and you pull out the tape on the right hand )

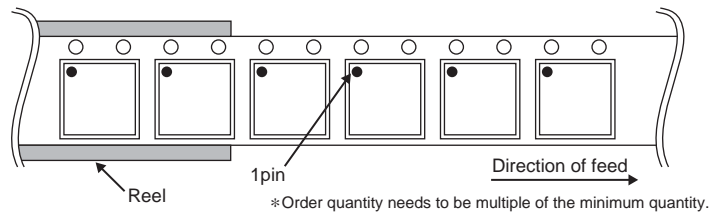

UQFN036V5050

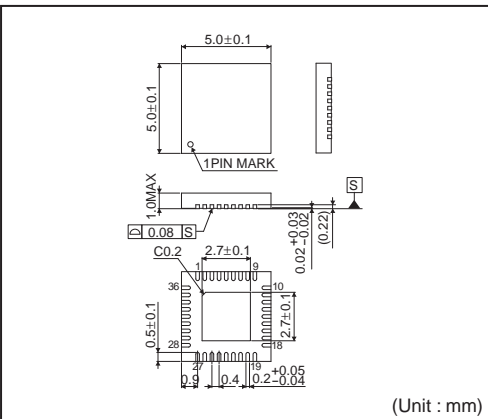

<Tape and Reel information>

Tape	Embossed carrier tape
Quantity	2500pcs
Direction of feed	E2 ( The direction is the 1pin of product is at the upper left when you hold reel on the left hand and you pull out the tape on the right hand )

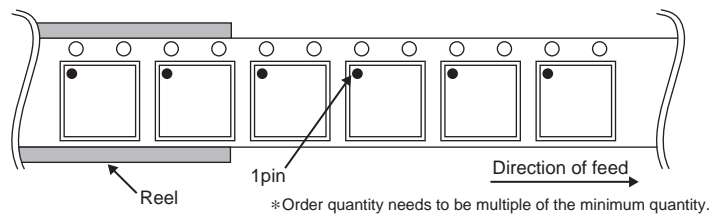

VQFN36

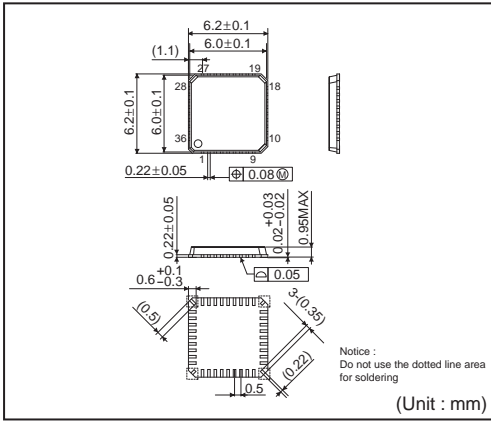

<Tape and Reel information>

Tape	Embossed carrier tape (with dry pack)
Quantity	2500pcs
Direction of feed	E2 ( The direction is the 1pin of product is at the upper left when you hold reel on the left hand and you pull out the tape on the right hand )

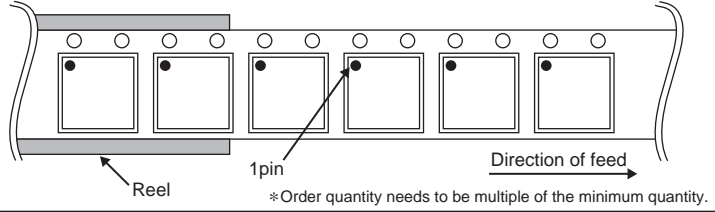



# Notice

## Precaution on using ROHM Products

- Our Products are designed and manufactured for application in ordinary electronic equipments (such as AV equipment, OA equipment, telecommunication equipment, home electronic appliances, amusement equipment, etc.). If you intend to use our Products in devices requiring extremely high reliability (such as medical equipment <sup>(Note 1)</sup>, transport equipment, traffic equipment, aircraft/spacecraft, nuclear power controllers, fuel controllers, car equipment including car accessories, safety devices, etc.) and whose malfunction or failure may cause loss of human life, bodily injury or serious damage to property ("Specific Applications"), please consult with the ROHM sales representative in advance. Unless otherwise agreed in writing by ROHM in advance, ROHM shall not be in any way responsible or liable for any damages, expenses or losses incurred by you or third parties arising from the use of any ROHM's Products for Specific Applications.

(Note1) Medical Equipment Classification of the Specific Applications

JAPAN	USA	EU	CHINA
CLASS III	CLASS III	CLASS II b	CLASS III
CLASS IV		CLASS III	

- ROHM designs and manufactures its Products subject to strict quality control system. However, semiconductor products can fail or malfunction at a certain rate. Please be sure to implement, at your own responsibilities, adequate safety measures including but not limited to fail-safe design against the physical injury, damage to any property, which a failure or malfunction of our Products may cause. The following are examples of safety measures:
  - Installation of protection circuits or other protective devices to improve system safety
  - Installation of redundant circuits to reduce the impact of single or multiple circuit failure
- Our Products are designed and manufactured for use under standard conditions and not under any special or extraordinary environments or conditions, as exemplified below. Accordingly, ROHM shall not be in any way responsible or liable for any damages, expenses or losses arising from the use of any ROHM's Products under any special or extraordinary environments or conditions. If you intend to use our Products under any special or extraordinary environments or conditions (as exemplified below), your independent verification and confirmation of product performance, reliability, etc. prior to use, must be necessary:
  - Use of our Products in any types of liquid, including water, oils, chemicals, and organic solvents
  - Use of our Products outdoors or in places where the Products are exposed to direct sunlight or dust
  - Use of our Products in places where the Products are exposed to sea wind or corrosive gases, including Cl<sub>2</sub>, H<sub>2</sub>S, NH<sub>3</sub>, SO<sub>2</sub>, and NO<sub>2</sub>
  - Use of our Products in places where the Products are exposed to static electricity or electromagnetic waves
  - Use of our Products in proximity to heat-producing components, plastic cords, or other flammable items
  - Sealing or coating our Products with resin or other coating materials
  - Use of our Products without cleaning residue of flux (even if you use no-clean type fluxes, cleaning residue of flux is recommended); or Washing our Products by using water or water-soluble cleaning agents for cleaning residue after soldering
  - Use of the Products in places subject to dew condensation
- The Products are not subject to radiation-proof design.
- Please verify and confirm characteristics of the final or mounted products in using the Products.
- In particular, if a transient load (a large amount of load applied in a short period of time, such as pulse. is applied, confirmation of performance characteristics after on-board mounting is strongly recommended. Avoid applying power exceeding normal rated power; exceeding the power rating under steady-state loading condition may negatively affect product performance and reliability.
- De-rate Power Dissipation (Pd) depending on Ambient temperature (Ta). When used in sealed area, confirm the actual ambient temperature.
- Confirm that operation temperature is within the specified range described in the product specification.
- ROHM shall not be in any way responsible or liable for failure induced under deviant condition from what is defined in this document.

## Precaution for Mounting / Circuit board design

- When a highly active halogenous (chlorine, bromine, etc.) flux is used, the residue of flux may negatively affect product performance and reliability.
- In principle, the reflow soldering method must be used; if flow soldering method is preferred, please consult with the ROHM representative in advance.

For details, please refer to ROHM Mounting specification

**Precautions Regarding Application Examples and External Circuits**

1. If change is made to the constant of an external circuit, please allow a sufficient margin considering variations of the characteristics of the Products and external components, including transient characteristics, as well as static characteristics.
2. You agree that application notes, reference designs, and associated data and information contained in this document are presented only as guidance for Products use. Therefore, in case you use such information, you are solely responsible for it and you must exercise your own independent verification and judgment in the use of such information contained in this document. ROHM shall not be in any way responsible or liable for any damages, expenses or losses incurred by you or third parties arising from the use of such information.

**Precaution for Electrostatic**

This Product is electrostatic sensitive product, which may be damaged due to electrostatic discharge. Please take proper caution in your manufacturing process and storage so that voltage exceeding the Products maximum rating will not be applied to Products. Please take special care under dry condition (e.g. Grounding of human body / equipment / solder iron, isolation from charged objects, setting of ionizer, friction prevention and temperature / humidity control).

**Precaution for Storage / Transportation**

1. Product performance and soldered connections may deteriorate if the Products are stored in the places where:
  - [a] the Products are exposed to sea winds or corrosive gases, including Cl<sub>2</sub>, H<sub>2</sub>S, NH<sub>3</sub>, SO<sub>2</sub>, and NO<sub>2</sub>
  - [b] the temperature or humidity exceeds those recommended by ROHM
  - [c] the Products are exposed to direct sunshine or condensation
  - [d] the Products are exposed to high Electrostatic
2. Even under ROHM recommended storage condition, solderability of products out of recommended storage time period may be degraded. It is strongly recommended to confirm solderability before using Products of which storage time is exceeding the recommended storage time period.
3. Store / transport cartons in the correct direction, which is indicated on a carton with a symbol. Otherwise bent leads may occur due to excessive stress applied when dropping of a carton.
4. Use Products within the specified time after opening a humidity barrier bag. Baking is required before using Products of which storage time is exceeding the recommended storage time period.

**Precaution for Product Label**

QR code printed on ROHM Products label is for ROHM's internal use only.

**Precaution for Disposition**

When disposing Products please dispose them properly using an authorized industry waste company.

**Precaution for Foreign Exchange and Foreign Trade act**

Since our Products might fall under controlled goods prescribed by the applicable foreign exchange and foreign trade act, please consult with ROHM representative in case of export.

**Precaution Regarding Intellectual Property Rights**

1. All information and data including but not limited to application example contained in this document is for reference only. ROHM does not warrant that foregoing information or data will not infringe any intellectual property rights or any other rights of any third party regarding such information or data. ROHM shall not be in any way responsible or liable for infringement of any intellectual property rights or other damages arising from use of such information or data.:
2. No license, expressly or implied, is granted hereby under any intellectual property rights or other rights of ROHM or any third parties with respect to the information contained in this document.

**Other Precaution**

1. This document may not be reprinted or reproduced, in whole or in part, without prior written consent of ROHM.
2. The Products may not be disassembled, converted, modified, reproduced or otherwise changed without prior written consent of ROHM.
3. In no event shall you use in any way whatsoever the Products and the related technical information contained in the Products or this document for any military purposes, including but not limited to, the development of mass-destruction weapons.
4. The proper names of companies or products described in this document are trademarks or registered trademarks of ROHM, its affiliated companies or third parties.

**General Precaution**

1. Before you use our Products, you are requested to carefully read this document and fully understand its contents. ROHM shall not be in any way responsible or liable for failure, malfunction or accident arising from the use of any ROHM's Products against warning, caution or note contained in this document.
2. All information contained in this document is current as of the issuing date and subject to change without any prior notice. Before purchasing or using ROHM's Products, please confirm the latest information with a ROHM sales representative.
3. The information contained in this document is provided on an "as is" basis and ROHM does not warrant that all information contained in this document is accurate and/or error-free. ROHM shall not be in any way responsible or liable for any damages, expenses or losses incurred by you or third parties resulting from inaccuracy or errors of or concerning such information.

Компания «Океан Электроники» предлагает заключение долгосрочных отношений при поставках импортных электронных компонентов на взаимовыгодных условиях!

Наши преимущества:

- Поставка оригинальных импортных электронных компонентов напрямую с производств Америки, Европы и Азии, а так же с крупнейших складов мира;
- Широкая линейка поставок активных и пассивных импортных электронных компонентов (более 30 млн. наименований);
- Поставка сложных, дефицитных, либо снятых с производства позиций;
- Оперативные сроки поставки под заказ (от 5 рабочих дней);
- Экспресс доставка в любую точку России;
- Помощь Конструкторского Отдела и консультации квалифицированных инженеров;
- Техническая поддержка проекта, помощь в подборе аналогов, поставка прототипов;
- Поставка электронных компонентов под контролем ВП;
- Система менеджмента качества сертифицирована по Международному стандарту ISO 9001;
- При необходимости вся продукция военного и аэрокосмического назначения проходит испытания и сертификацию в лаборатории (по согласованию с заказчиком);
- Поставка специализированных компонентов военного и аэрокосмического уровня качества (Xilinx, Altera, Analog Devices, Intersil, Interpoint, Microsemi, Actel, Aeroflex, Peregrine, VPT, Syfer, Eurofarad, Texas Instruments, MS Kennedy, Miteq, Cobham, E2V, MA-COM, Hittite, Mini-Circuits, General Dynamics и др.);

Компания «Океан Электроники» является официальным дистрибьютором и эксклюзивным представителем в России одного из крупнейших производителей разъемов военного и аэрокосмического назначения «JONHON», а так же официальным дистрибьютором и эксклюзивным представителем в России производителя высокотехнологичных и надежных решений для передачи СВЧ сигналов «FORSTAR».



## JONHON

«JONHON» (основан в 1970 г.)

Разъемы специального, военного и аэрокосмического назначения:

(Применяются в военной, авиационной, аэрокосмической, морской, железнодорожной, горно- и нефтедобывающей отраслях промышленности)

«FORSTAR» (основан в 1998 г.)

ВЧ соединители, коаксиальные кабели,  
кабельные сборки и микроволновые компоненты:

(Применяются в телекоммуникациях гражданского и специального назначения, в средствах связи, РЛС, а так же военной, авиационной и аэрокосмической отраслях промышленности).



Телефон: 8 (812) 309-75-97 (многоканальный)

Факс: 8 (812) 320-03-32

Электронная почта: [ocean@oceanchips.ru](mailto:ocean@oceanchips.ru)

Web: <http://oceanchips.ru/>

Адрес: 198099, г. Санкт-Петербург, ул. Калинина, д. 2, корп. 4, лит. А