

**1.8V/2.5V/3.3V, 100MHz, Low Skew 1:6 Crystal to LVC MOS Clock Buffer**
**Features**

- Six low skew outputs: < 80ps
- Crystal oscillator input: 10MHz to 50MHz
- Switching frequency up to 100 MHz
- Fast output rise/fall time: < 800ps
- Synchronous output enables
- Industrial Temperature range: -40°C to +85°C
- 1.8V, 2.5V and 3.3V operation
  - Mixed 3.3V core/2.5V output, 3.3V core/1.8V output, and 2.5V core/1.8V output operating voltages
- Packaging (Pb-free & Green available):
  - 16-pin 173-mil wide TSSOP (L)

**Description**

Pericom Semiconductor's PI6C10806B is a low skew six output crystal oscillator driver. Crystal oscillator input range is from 10MHz to 50MHz. If XTAL\_IN is driven with a signal source, then the input frequency can be as high as 100MHz. PI6C10806B, the outputs are configured into 2 groups: a five output and a single output; each with independent output enable.

PI6C10806B has a wide range of operating voltages: 1.8V, 2.5V, and 3.3V. This feature paired with the low output-to-output and part-to-part skew makes the device ideal for low voltage, low power, high frequency single ended applications; such as networking

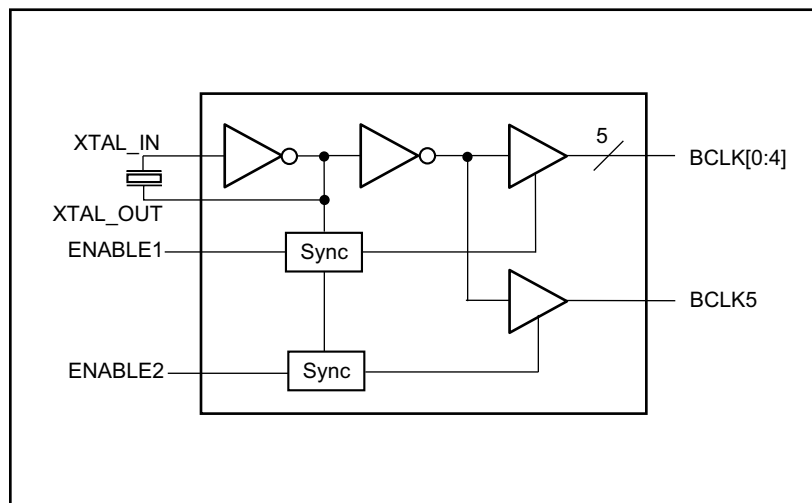
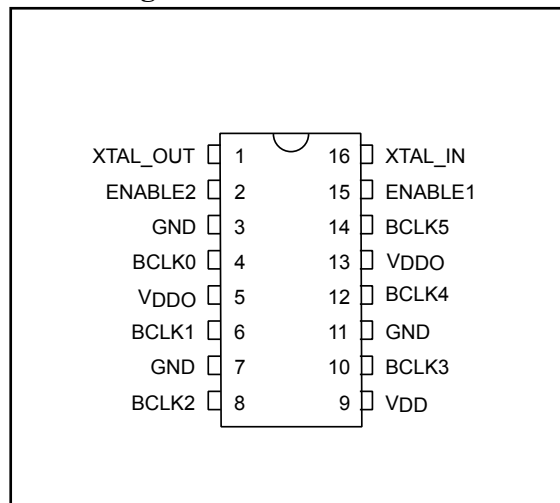
**Block Diagram**

**Pin Configuration**

**Pin Description**

Pin Name	Description
ENABLE1, ENABLE2	Active High Output Enable Inputs
XTAL_IN	Crystal interface
XTAL_OUT	Crystal interface
BCLK[0:5]	Clock Outputs
GND	Ground
V <sub>DD</sub>	Core Power
V <sub>DDO</sub>	Output Power

**Truth Table<sup>(1)</sup>**

Inputs		Outputs	
ENABLE1	ENABLE2	BCLK[0:4]	BCLK5
L	L	L	L
L	H	L	Switching
H	L	Switching	L
H	H	Switching	Switching

**Note:**

1. H = High Voltage Level, L = Low Voltage Level

**Power Supply DC Characteristics** ( $V_{DD}/V_{DDO} = 3.3V \pm 5\%$ ,  $T_A = -40^\circ C$  to  $85^\circ C$ )

Symbols	Parameters	Test Conditions	Min.	Typ	Max.	Units
$V_{DD}$	Core Supply Voltage		3.135	3.3	3.465	V
$V_{DDO}$	Output Supply Voltage		3.135	3.3	3.465	V
$I_{DD}$	Power Supply Current	ENABLE1:2 = '00'			10	mA
$I_{DDO}$	Output Supply Current	ENABLE1:2 = '00'			5	mA

**Power Supply DC Characteristics** ( $V_{DD}/V_{DDO} = 2.5V \pm 5\%$ ,  $T_A = -40^\circ C$  to  $85^\circ C$ )

Symbols	Parameters	Test Conditions	Min.	Typ	Max.	Units
$V_{DD}$	Core Supply Voltage		2.375	2.5	2.625	V
$V_{DDO}$	Output Supply Voltage		2.375	2.5	2.625	V
$I_{DD}$	Power Supply Current	ENABLE1:2 = '00'			8	mA
$I_{DDO}$	Output Supply Current	ENABLE1:2 = '00'			4	mA

**Power Supply DC Characteristics** ( $V_{DD}/V_{DDO} = 1.8V \pm 0.2V$ ,  $T_A = -40^\circ C$  to  $85^\circ C$ )

Symbols	Parameters	Test Conditions	Min.	Typ	Max.	Units
$V_{DD}$	Core Supply Voltage		1.6	1.8	2.0	V
$V_{DDO}$	Output Supply Voltage		1.6	1.8	2.0	V
$I_{DD}$	Power Supply Current	ENABLE1:2 = '00'			5	mA
$I_{DDO}$	Output Supply Current	ENABLE1:2 = '00'			3	mA

**Power Supply DC Characteristics** ( $V_{DD} = 3.3V \pm 5\%$ ,  $V_{DDO} = 2.5V \pm 5\%$ ,  $T_A = -40^\circ C$  to  $85^\circ C$ )

Symbols	Parameters	Test Conditions	Min.	Typ	Max.	Units
$V_{DD}$	Core Supply Voltage		3.135	3.3	3.465	V
$V_{DDO}$	Output Supply Voltage		2.375	2.5	2.625	V
$I_{DD}$	Power Supply Current	ENABLE1:2 = '00'			10	mA
$I_{DDO}$	Output Supply Current	ENABLE1:2 = '00'			4	mA

**Power Supply DC Characteristics** ( $V_{DD} = 3.3V \pm 5\%$ ,  $V_{DDO} = 1.8V \pm 0.2V$ ,  $T_A = -40^\circ C$  to  $85^\circ C$ )

Symbols	Parameters	Test Conditions	Min.	Typ	Max.	Units
$V_{DD}$	Core Supply Voltage		3.135	3.3	3.465	V
$V_{DDO}$	Output Supply Voltage		1.6	1.8	2.0	V
$I_{DD}$	Power Supply Current	ENABLE1:2 = '00'			10	mA
$I_{DDO}$	Output Supply Current	ENABLE1:2 = '00'			3	mA

**Power Supply DC Characteristics** ( $V_{DD} = 2.5V \pm 5\%$ ,  $V_{DDO} = 1.8V \pm 0.2V$ ,  $T_A = -40^\circ C$  to  $85^\circ C$ )

Symbols	Parameters	Test Conditions	Min.	Typ	Max.	Units
$V_{DD}$	Core Supply Voltage		2.375	2.5	2.625	V
$V_{DDO}$	Output Supply Voltage		1.6	1.8	2.0	V
$I_{DD}$	Power Supply Current	ENABLE1:2 = '00'			8	mA
$I_{DDO}$	Output Supply Current	ENABLE1:2 = '00'			3	mA

**I/O DC Characteristics** ( $T_A = -40^\circ C$  to  $85^\circ C$ )

Symbols	Parameters	Test Conditions	Min.	Typ	Max.	Units	
$V_{IH}$	Input High Voltage	ENABLE 1, ENABLE 2	$V_{DD} = 3.3V \pm 5\%$	2		$V_{DDO} + 0.3$	V
			$V_{DD} = 2.5V \pm 5\%$	1.7		$V_{DDO} + 0.3$	V
			$V_{DD} = 1.8V \pm 0.2V$	$1.65 * V_{DDO}$		$V_{DDO} + 0.3$	V
$V_{IL}$	Input Low Voltage	ENABLE 1, ENABLE 2	$V_{DD} = 3.3V \pm 5\%$	-0.3		0.8	V
			$V_{DD} = 2.5V \pm 5\%$	-0.3		0.7	V
			$V_{DD} = 1.8V \pm 0.2V$	-0.3		$0.35 * V_{DDO}$	V
$V_{OH}$	Output High Voltage		$V_{DDO} = 3.3V \pm 5\%$ <sup>(1)</sup>	2.6			V
			$V_{DDO} = 2.5V \pm 5\%$ ; $I_{OH} = -1mA$	2			V
			$V_{DDO} = 2.5V \pm 5\%$ <sup>(1)</sup>	1.8			V
			$V_{DDO} = 1.8V \pm 0.2V$ <sup>(1)</sup>	$V_{DDO} - 0.3$			V
$V_{OL}$	Output Low Voltage		$V_{DD} = 3.3V \pm 5\%$ <sup>(1)</sup>			0.5	V
			$V_{DDO} = 2.5V \pm 5\%$ ; $I_{OH} = -1mA$			0.4	V
			$V_{DDO} = 2.5V \pm 5\%$ <sup>(1)</sup>			0.45	V
			$V_{DDO} = 1.8V \pm 0.2V$ <sup>(1)</sup>			0.35	V

**Notes:**

1. For Max. or Min. conditions, use appropriate operating  $V_{DD}$  and  $T_A$  values.

**3.3V Absolute Maximum Ratings** (Above which the useful life may be impaired. For user guidelines only, not tested.)

Storage Temperature.....	-65°C to +150°C
V <sub>DD</sub> , V <sub>DDO</sub> Voltage.....	-0.5V to +3.6V
Output Voltage (max. 4.6V).....	-0.5V to V <sub>DD</sub> +0.5V
Input Voltage (max 4.6V).....	-0.5V to V <sub>DD</sub> +0.5V

**Note:**  
Stresses greater than those listed under MAXIMUM RATINGS may cause permanent damage to the device. This is a stress rating only and functional operation of the device at these or any other conditions above those indicated in the operational sections of this specification is not implied. Exposure to absolute maximum rating conditions for extended periods may affect reliability.

**3.3V I/O DC Characteristics** (Over Operating Range: V<sub>DD</sub> = 3.3V ± 5%, T<sub>A</sub> = -40° to 85°C)

Parameters	Description	Test Conditions <sup>(1)</sup>	Min.	Typ. <sup>(2)</sup>	Max.	Units
V <sub>DDO</sub>	I/O Supply Voltage		3.135	3.3	3.465	
V <sub>IH</sub>	Input HIGH Voltage	Logic HIGH level	2		V <sub>DD</sub> +0.3	V
V <sub>IL</sub>	Input LOW Voltage	Logic LOW level	-0.3		1.3	
V <sub>OH</sub>	Output High Voltage	V <sub>DDO</sub> = Min., V <sub>IN</sub> = V <sub>IH</sub> or V <sub>IL</sub>	I <sub>OH</sub> = -1mA	2		V
			I <sub>OH</sub> = -8mA	2		
V <sub>OL</sub>	Output LOW Voltage	V <sub>DDO</sub> = Min., V <sub>IN</sub> = V <sub>IH</sub> or V <sub>IL</sub>	I <sub>OL</sub> = 1mA		0.4	V
			I <sub>OL</sub> = 8mA		0.4	

**Notes:**

- For Max. or Min. conditions, use appropriate operating range values.
- Typical values are at V<sub>DD</sub> = 3.3V, +25°C ambient and maximum loading.

**3.3V I/O AC Characteristics** (Over Operating Range: V<sub>DD</sub>/V<sub>DDO</sub> = 3.3V ± 5%, T<sub>A</sub> = -40° to 85°C)

Parameters	Description	Test Conditions <sup>(1)</sup>	Min.	Typ	Max.	Units
f <sub>OUT</sub>	Output Frequency	Using Crystal	10		50	MHz
		External Clock <sup>(2)</sup>	0		100	
t <sub>DC</sub>	Output Duty Cycle	@ V <sub>DDO</sub> /2	47		53	%
t <sub>R</sub> /t <sub>F</sub>	CLKn Rise/Fall Time	20% to 80%	150		800	ps
RMS	Random RMS Phase Jitter	25MHz @ Integration Range 100Hz - 1MHz		0.098		ps
t <sub>SK(O)</sub> <sup>(3)</sup>	Output to Output Skew between any two outputs of the same device @ same transition	@V <sub>DDO</sub> /2			80	ps
t <sub>DIS</sub> , t <sub>EN</sub> <sup>(4)</sup>	Output Enable/Disable	@V <sub>DDO</sub> /2			4	cycles

**Notes:**

- Unless noted otherwise, all parameters are tested with xtal @ f <= Fxtal\_max,; outputs are terminated @ 50Ω to V<sub>DDO</sub>/2, see waveforms.
- External clock source is driving XTAL\_IN input
- Identical conditions: loading, transitions, supply voltage, temperature, package type and speed grade.
- These parameters are guaranteed, but not tested. Max delay is 4 cycles. Min. setup time = 3ns.

**2.5V Absolute Maximum Ratings** (Above which the useful life may be impaired. For user guidelines only, not tested.)

Storage Temperature.....	-65°C to +150°C
V <sub>DD</sub> , V <sub>DDO</sub> Voltage.....	-0.5V to +3.6V
Output Voltage (max. 3.6V).....	-0.5V to V <sub>DD</sub> +0.5V
Input Voltage (max 3.6V).....	-0.5V to V <sub>DD</sub> +0.5V

**Note:**

Stresses greater than those listed under MAXIMUM RATINGS may cause permanent damage to the device. This is a stress rating only and functional operation of the device at these or any other conditions above those indicated in the operational sections of this specification is not implied. Exposure to absolute maximum rating conditions for extended periods may affect reliability.

**2.5V I/O DC Characteristics** (Over Operating Range: V<sub>DD</sub> = 2.5V ± 5%, T<sub>A</sub> = -40° to 85°C)

Parameters	Description	Test Conditions <sup>(1)</sup>	Min.	Typ. <sup>(2)</sup>	Max.	Units
V <sub>DDO</sub>	I/O Supply Voltage		2.375	2.5	2.625	
V <sub>IH</sub>	Input HIGH Voltage	Logic HIGH level	1.7		V <sub>DD</sub> +0.3	V
V <sub>IL</sub>	Input LOW Voltage	Logic LOW level	-0.3		0.7	
V <sub>OH</sub>	Output High Voltage	V <sub>DDO</sub> = Min., V <sub>IN</sub> = V <sub>IH</sub> or V <sub>IL</sub>	I <sub>OH</sub> = -1mA	2		V
			I <sub>OH</sub> = -8mA	2		
V <sub>OL</sub>	Output LOW Voltage	V <sub>DDO</sub> = Min., V <sub>IN</sub> = V <sub>IH</sub> or V <sub>IL</sub>	I <sub>OL</sub> = 1mA		0.4	V
			I <sub>OL</sub> = 8mA		0.4	

**Notes:**

- For Max. or Min. conditions, use appropriate operating range values.
- Typical values are at V<sub>DD</sub> = 3.3V, +25°C ambient and maximum loading.

**2.5V I/O AC Characteristics** (Over Operating Range: V<sub>DD</sub>/V<sub>DDO</sub> = 2.5V ± 5%, T<sub>A</sub> = -40° to 85°C)

Parameters	Description	Test Conditions <sup>(1)</sup>	Min.	Typ	Max.	Units
f <sub>OUT</sub>	Output Frequency	Using Crystal	10		50	MHz
		External Clock <sup>(2)</sup>	0		100	
t <sub>DC</sub>	Output Duty Cycle	@ V <sub>DDO</sub> /2	47		55	%
t <sub>R</sub> /t <sub>F</sub>	CLKn Rise/Fall Time	20% to 80%	150		800	ps
RMS	Random RMS Phase Jitter	25MHz @ Integration Range 100Hz - 1MHz		0.112		ps
t <sub>SK(O)</sub> <sup>(3)</sup>	Output to Output Skew between any two outputs of the same device @ same transition	@V <sub>DDO</sub> /2			80	ps
t <sub>DIS</sub> , t <sub>EN</sub> <sup>(4)</sup>	Output Enable/Disable	@V <sub>DDO</sub> /2			4	cycles

**Notes:**

- Unless noted otherwise, all parameters are tested with xtal @ f <= Fxtal\_max,; outputs are terminated @ 50Ω to V<sub>DDO</sub>/2, see waveforms.
- External clock source is driving XTAL\_IN input
- Identical conditions: loading, transitions, supply voltage, temperature, package type and speed grade.
- These parameters are guaranteed, but not tested. Max delay is 4 cycles. Min. setup time = 3ns.

**1.8V Absolute Maximum Ratings** (Above which the useful life may be impaired. For user guidelines only, not tested.)

Storage Temperature.....	-65°C to +150°C
V <sub>DDO</sub> , V <sub>DD</sub> Voltage.....	-0.5V to +2.5V
Output Voltage (max 2.5V) .....	-0.5V to V <sub>DD</sub> +0.5V
Input Voltage (max 2.5V) .....	-0.5V to V <sub>DD</sub> +0.5V

**Note:**

Stresses greater than those listed under MAXIMUM RATINGS may cause permanent damage to the device. This is a stress rating only and functional operation of the device at these or any other conditions above those indicated in the operational sections of this specification is not implied. Exposure to absolute maximum rating conditions for extended periods may affect reliability.

**1.8V I/O DC Characteristics** (Over Operating Range: V<sub>DDO</sub> = 1.8V ± 0.2V, T<sub>A</sub> = -40° to 85°C)

Parameters	Description	Test Conditions <sup>(1)</sup>	Min.	Typ. <sup>(2)</sup>	Max.	Units
V <sub>DDO</sub>	I/O Supply Voltage		1.6	1.8	2.0	V
V <sub>IH</sub>	Input HIGH Voltage	Logic HIGH level	0.65*V <sub>DD</sub>		V <sub>DD</sub> +0.3	
V <sub>IL</sub>	Input LOW Voltage	Logic LOW level	-0.3		0.35*V <sub>DD</sub>	
I <sub>L</sub>	Input Current	V <sub>DD</sub> = Max, V <sub>IN</sub> = V <sub>DD</sub> or GND I pin			15	μA
V <sub>OH</sub>	Output High Voltage	V <sub>DD</sub> = Min., V <sub>IN</sub> = V <sub>IH</sub> or V <sub>IL</sub>	I <sub>OH</sub> = -2mA	1.2		V
			I <sub>OH</sub> = -8mA	1.2		
V <sub>OL</sub>	Output Low Voltage	V <sub>DD</sub> = Min., V <sub>IN</sub> = V <sub>IH</sub> or V <sub>IL</sub>	I <sub>OL</sub> = 2mA		0.35	
			I <sub>OL</sub> = 8mA		0.35	

**Notes:**

- For Max. or Min. conditions, use appropriate operating V<sub>DD</sub> and T<sub>a</sub> values.
- Typical values are at V<sub>DD</sub> = 1.8V, +25°C ambient and maximum loading.

**1.8V I/O AC Characteristics** (Over Operating Range: V<sub>DD</sub> / V<sub>DDO</sub> = 1.8V ± 0.2V, T<sub>A</sub> = -40° to 85°C)

Parameters	Description	Test Conditions <sup>(1)</sup>	Min.	Typ	Max.	Units
f <sub>OUT</sub>	Output Frequency	Using Crystal	10		50	MHz
		External Clock <sup>(2)</sup>	0		100	
t <sub>DC</sub>	Output Duty Cycle	@ V <sub>DDO</sub> /2	47		55	%
RMS	Random RMS Phase Jitter	25MHz @ Integration Range 100Hz - 1MHz		0.096 @1.8V		ps
t <sub>R</sub> /t <sub>F</sub>	CLK <sub>n</sub> Rise/Fall Time	20% to 80%	150		800	ps
t <sub>SK(O)</sub> <sup>(3)</sup>	Output to Output Skew between any two outputs of the same device @ same transition	@V <sub>DDO</sub> /2			80	ps
t <sub>DIS</sub> , t <sub>EN</sub> <sup>(4)</sup>	Output Enable/Disable	@V <sub>DDO</sub> /2			4	cycles

**Notes:**

- Unless noted otherwise, all parameters are tested with xtal @ f ≤ F<sub>xtal\_max</sub>; outputs are terminated @ 50Ω to V<sub>DDO</sub>/2, see waveforms.
- External clock source is driving XTAL\_IN input
- Identical conditions: loading, transitions, supply voltage, temperature, package type and speed grade.
- These parameters are guaranteed, but not tested. Max delay is 4 cycles. Min. setup time = 3ns.

**AC Characteristics** ( $V_{DD} = 3.3V \pm 5\%$ ,  $V_{DDO} = 2.5V \pm 5\%$ ,  $T_A = -40^\circ C$  to  $85^\circ C$ )

Symbols	Parameters	Test Conditions <sup>(1)</sup>	Min.	Typ	Max.	Units
f <sub>MAX</sub>	Output Frequency	Using External Crystal	10		50	MHz
		Using External Clock Source <sup>(2)</sup>	DC		100	MHz
odc	Output Duty Cycle		48		52	%
t <sub>SK(O)</sub> <sup>(3)</sup>	Output Skew <sup>(2)</sup> <sup>(4)</sup>				80	ps
t <sub>jit(Ø)</sub>	RMS Phase Jitter (Random)	25MHz @ Integration Range: 100Hz-1MHz		0.091		ps
t <sub>R</sub> /t <sub>F</sub>	Output Rise/Fall Time	20% to 80%	200		800	ps
t <sub>EN</sub> <sup>(4)</sup>	Output Enable Time <sup>(3)</sup>	ENABLE1			4	cycles
		ENABLE2			4	cycles
t <sub>DIS</sub>	Output Disable Time <sup>(3)</sup>	ENABLE1			4	cycles
		ENABLE2			4	cycles

**Notes:**

1. Unless noted otherwise, all parameters are tested with xtal @  $f \leq F_{xtal\_max}$ ; outputs are terminated @  $50\Omega$  to  $V_{DDO}/2$ , see waveforms.
2. External clock source is driving XTAL\_IN input
3. Identical conditions: loading, transitions, supply voltage, temperature, package type and speed grade.
4. These parameters are guaranteed, but not tested. Max delay is 4 cycles. Min. setup time = 3ns.

**AC Characteristics** ( $V_{DD} = 3.3V \pm 5\%$ ,  $V_{DDO} = 1.8V \pm 0.2V$ ,  $T_A = -40^\circ C$  to  $85^\circ C$ )

Symbols	Parameters	Test Conditions <sup>(1)</sup>	Min.	Typ	Max.	Units
f <sub>MAX</sub>	Output Frequency	Using External Crystal	10		50	MHz
		Using External Clock Source <sup>(2)</sup>	DC		100	MHz
odc	Output Duty Cycle		48		52	%
t <sub>SK(O)</sub> <sup>(3)</sup>	Output Skew <sup>(2)</sup> <sup>(4)</sup>				80	ps
t <sub>jit(Ø)</sub>	RMS Phase Jitter (Random)	25MHz @ Integration Range: 100Hz-1MHz		0.122		ps
t <sub>R</sub> /t <sub>F</sub>	Output Rise/Fall Time	20% to 80%	200		900	ps
t <sub>EN</sub> <sup>(4)</sup>	Output Enable Time <sup>(3)</sup>	ENABLE1			4	cycles
		ENABLE2			4	cycles
t <sub>DIS</sub>	Output Disable Time <sup>(3)</sup>	ENABLE1			4	cycles
		ENABLE2			4	cycles

**Notes:**

1. Unless noted otherwise, all parameters are tested with xtal @  $f \leq F_{xtal\_max}$ ; outputs are terminated @  $50\Omega$  to  $V_{DDO}/2$ , see waveforms.
2. External clock source is driving XTAL\_IN input
3. Identical conditions: loading, transitions, supply voltage, temperature, package type and speed grade.
4. These parameters are guaranteed, but not tested. Max delay is 4 cycles. Min. setup time = 3ns.



**AC Characteristics** ( $V_{DD} = 2.5V \pm 5\%$ ,  $V_{DDO} = 1.8V \pm 0.2V$ ,  $T_A = -40^\circ\text{C}$  to  $85^\circ\text{C}$ )

Symbols	Parameters	Test Conditions	Min.	Typ	Max.	Units
$f_{MAX}$	Output Frequency	Using External Crystal	10		50	MHz
		Using External Clock Source <sup>(1)</sup>	DC		100	MHz
odc	Output Duty Cycle		47		53	%
$t_{SK(O)}$	Output Skew <sup>(2) (4)</sup>				80	ps
$t_{jit(\emptyset)}$	RMS Phase Jitter (Random)	25MHz @ Integration Range: 100Hz-1MHz		0.131		ps
$t_R/t_F$	Output Rise/Fall Time	20% to 80%	200		900	ps
$t_{EN}$	Output Enable Time <sup>(3)</sup>	ENABLE1			4	cycles
		ENABLE2			4	cycles
$t_{DIS}$	Output Disable Time <sup>(3)</sup>	ENABLE1			4	cycles
		ENABLE2			4	cycles

**Notes:**

All parameters measured at  $f=f_{MAX}$  using a crystal input unless noted otherwise.

Outputs are terminated at  $50\Omega$  to  $V_{DDO}/2$ .

1. XTAL\_IN can be overdriven relatively to a signal a crystal provides.
2. Defined as skew between outputs at the same supply voltage and with equal load conditions. Measured at  $V_{DDO}/2$ .
3. These parameters are guaranteed, but not tested.
4. This parameter is defined in accordance with JEDEC Standard 65.

**Jitter (typical phase noise at 25MHz)**

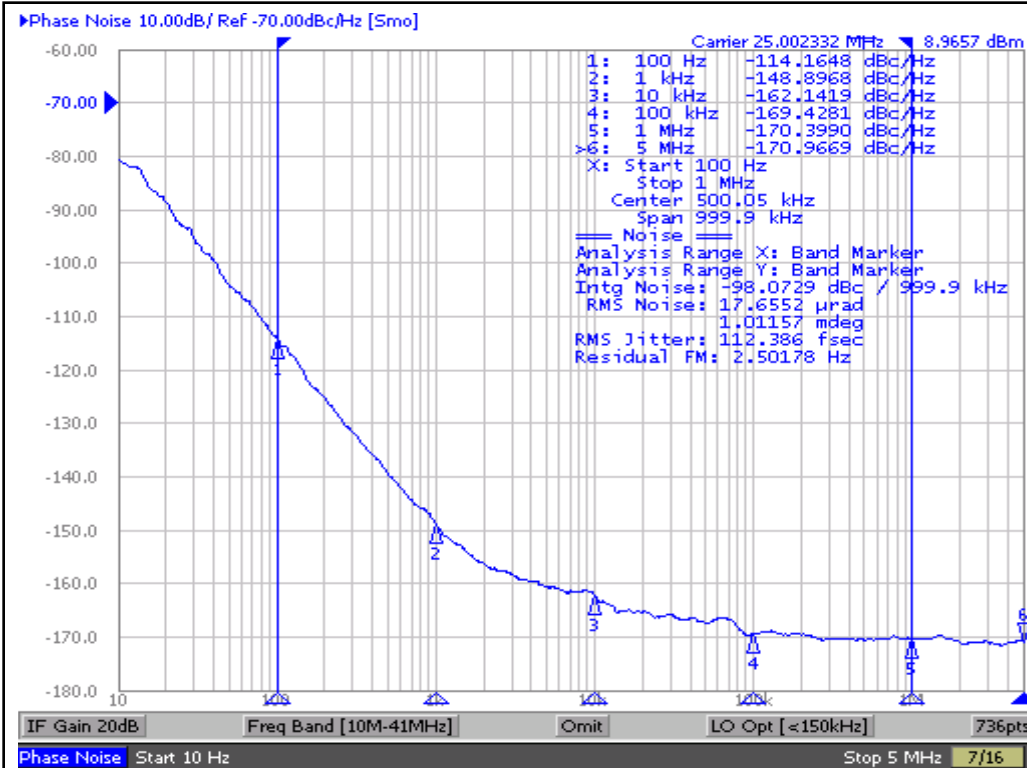

**2.5V Core/2.5V Output**  
**RMS phase jitter (Random)**  
**100Hz to 1MHz = 0.112ps (typical)**

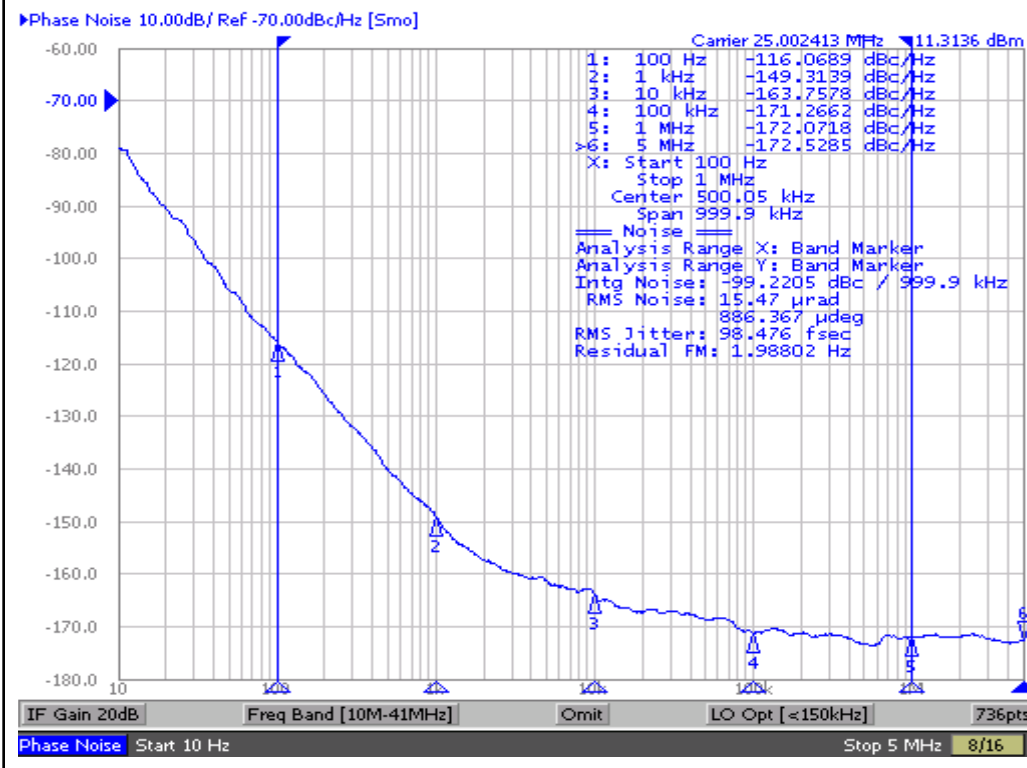

**3.3V Core/3.3V Output**  
**RMS phase jitter (Random)**  
**100Hz to 1MHz = 0.098ps (typical)**

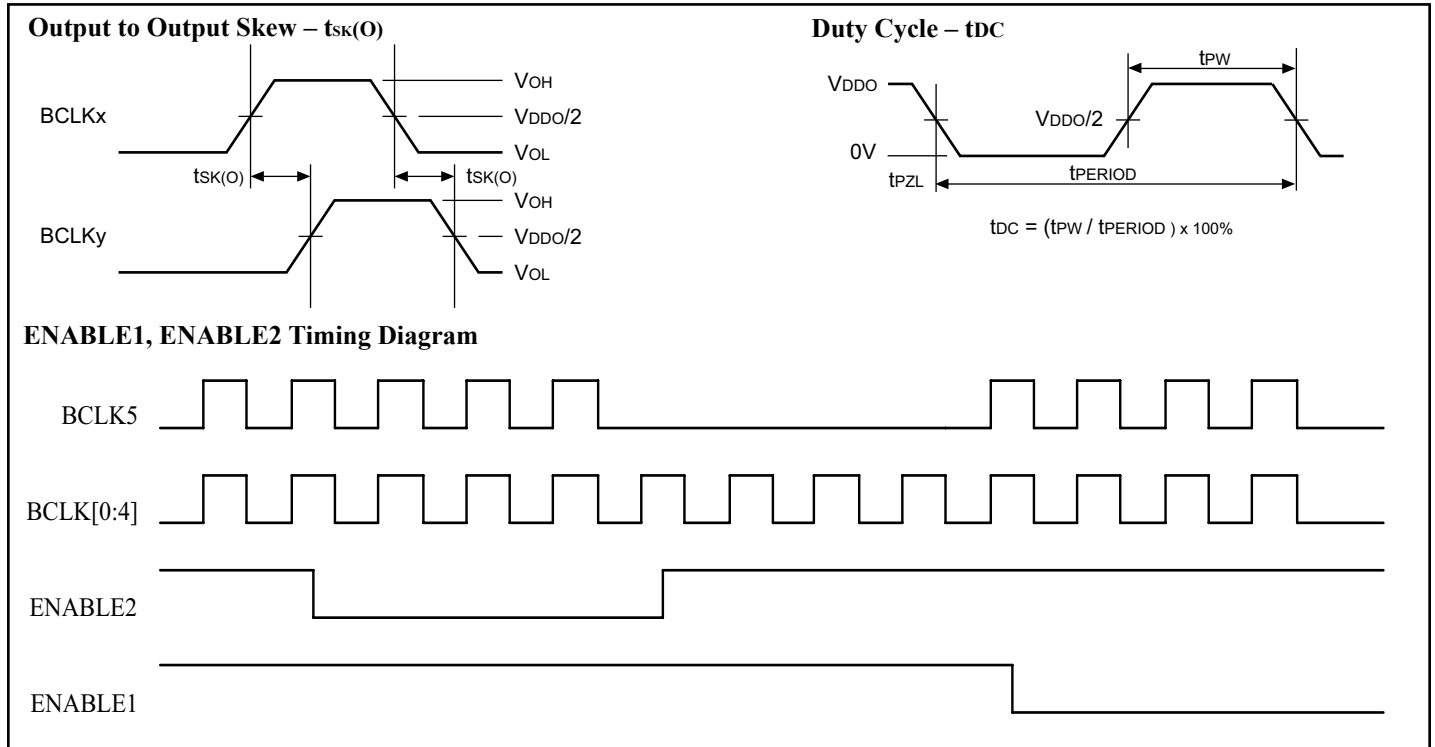
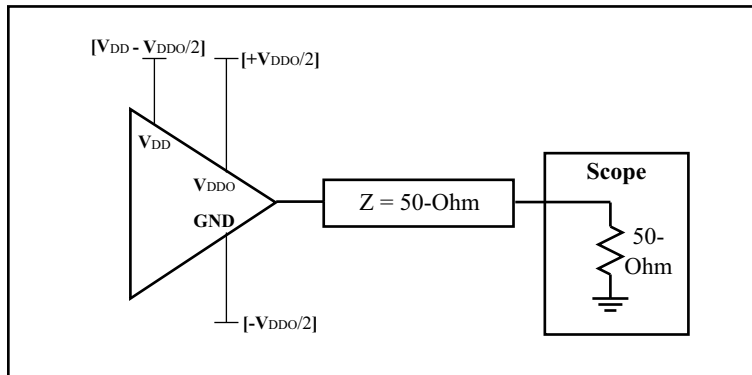
**Waveforms**

**AC Test Circuit Load**

**Note:**
 $V_{DD}/V_{DDO} = 1.8V \pm 0.2V,$   
 $2.5V \pm 5\%,$   
 $3.3V \pm 5\%$ 
**Crystal Characteristic** (link to "<http://www.pericom.com/saronix>" for more detailed crystal specifications)

Parameters	Description	Min	Typ	Max.	Units
OSCMODE	Mode of Oscillation	Fundamental			
FREQ	Frequency	10	25	50	MHz
ESR <sup>(1)</sup>	Equivalent Series Resistance	30		50	Ohm
CLOAD	Load Capacitance		18		pF
CSHUNT	Shunt Capacitance			7	pF
DRIVE level				1	mW

**Note:** 1. ESR value is dependent upon frequency of oscillation

## Application Notes

### Crystal circuit connection

The following diagram shows PI6C10806B crystal circuit connection with a parallel crystal. For the  $C_L=18\text{pF}$  crystal, it is suggested to use  $C1=15\text{pF}$ ,  $C2=15\text{pF}$ .  $C1$  and  $C2$  can be adjusted to fine tune to the target ppm of crystal oscillator according to different board layouts.  $R1$  is not recommended.

### Crystal Oscillator Circuit

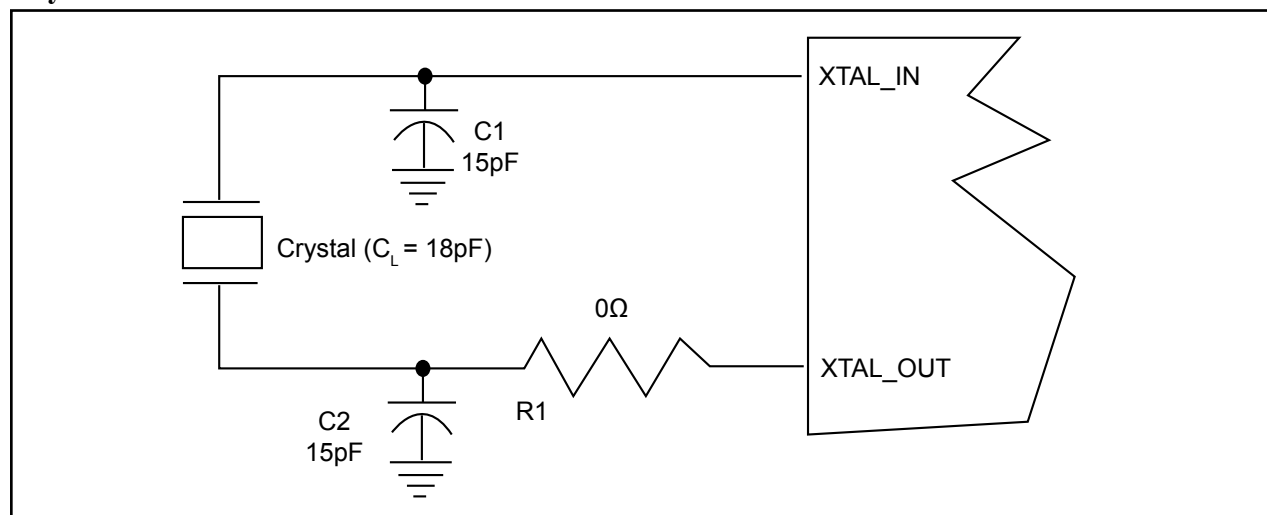

DOCUMENT CONTROL NO.  
 PD - 1310

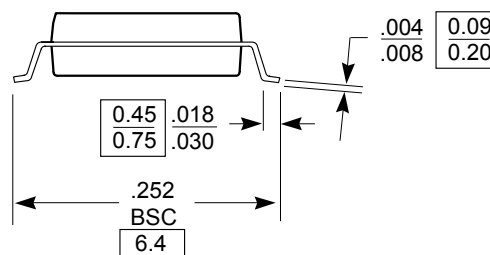
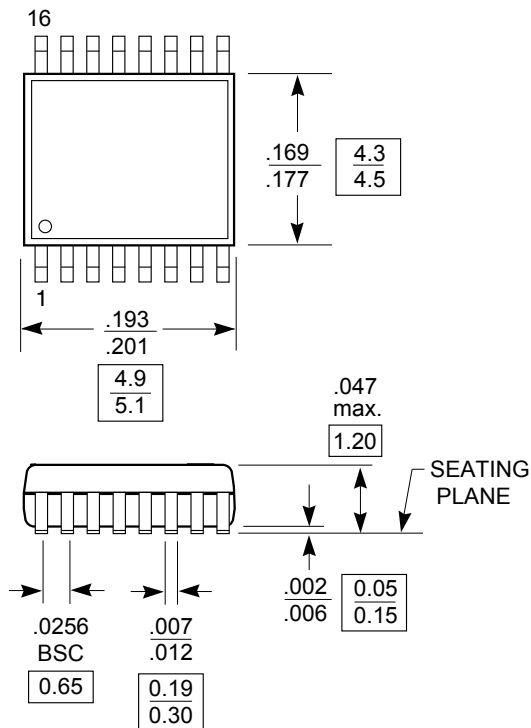
 REVISION: E  
 DATE: 03/09/05

**Note:**

1. Package Outline Exclusive of Mold Flash and Metal Burr
2. Controlling dimensions in millimeters
3. Ref: JEDEC MO-153F/AB

 Pericom Semiconductor Corporation  
 3545 N. 1st Street, San Jose, CA 95134  
 1-800-435-2335 • www.pericom.com

DESCRIPTION: 16-Pin, 173-Mil Wide, TSSOP

PACKAGE CODE: L

**Note:**

- For latest package info, please check: <http://www.pericom.com/products/packaging/mechanicals.php>

**PI6C10806B Ordering Information(1,2,3)**

Ordering Code	Package Code	Package Description
PI6C10806BLE	L	Pb-Free and Green 16-pin 173-mil TSSOP

**Notes:**

1. Thermal characteristics can be found on the company web site at [www.pericom.com/packaging/](http://www.pericom.com/packaging/)
2. E = Pb-free and Green
3. X suffix = Tape/Reel

# Mouser Electronics

Authorized Distributor

Click to View Pricing, Inventory, Delivery & Lifecycle Information:

[Diodes Incorporated:](#)

[PI6C10806BLE](#) [PI6C10806BLEX](#)

Компания «Океан Электроники» предлагает заключение долгосрочных отношений при поставках импортных электронных компонентов на взаимовыгодных условиях!

Наши преимущества:

- Поставка оригинальных импортных электронных компонентов напрямую с производств Америки, Европы и Азии, а так же с крупнейших складов мира;
- Широкая линейка поставок активных и пассивных импортных электронных компонентов (более 30 млн. наименований);
- Поставка сложных, дефицитных, либо снятых с производства позиций;
- Оперативные сроки поставки под заказ (от 5 рабочих дней);
- Экспресс доставка в любую точку России;
- Помощь Конструкторского Отдела и консультации квалифицированных инженеров;
- Техническая поддержка проекта, помощь в подборе аналогов, поставка прототипов;
- Поставка электронных компонентов под контролем ВП;
- Система менеджмента качества сертифицирована по Международному стандарту ISO 9001;
- При необходимости вся продукция военного и аэрокосмического назначения проходит испытания и сертификацию в лаборатории (по согласованию с заказчиком);
- Поставка специализированных компонентов военного и аэрокосмического уровня качества (Xilinx, Altera, Analog Devices, Intersil, Interpoint, Microsemi, Actel, Aeroflex, Peregrine, VPT, Syfer, Eurofarad, Texas Instruments, MS Kennedy, Miteq, Cobham, E2V, MA-COM, Hittite, Mini-Circuits, General Dynamics и др.);

Компания «Океан Электроники» является официальным дистрибьютором и эксклюзивным представителем в России одного из крупнейших производителей разъемов военного и аэрокосмического назначения «JONHON», а так же официальным дистрибьютором и эксклюзивным представителем в России производителя высокотехнологичных и надежных решений для передачи СВЧ сигналов «FORSTAR».



## JONHON

«JONHON» (основан в 1970 г.)

Разъемы специального, военного и аэрокосмического назначения:

(Применяются в военной, авиационной, аэрокосмической, морской, железнодорожной, горно- и нефтедобывающей отраслях промышленности)

«FORSTAR» (основан в 1998 г.)

ВЧ соединители, коаксиальные кабели, кабельные сборки и микроволновые компоненты:

(Применяются в телекоммуникациях гражданского и специального назначения, в средствах связи, РЛС, а так же военной, авиационной и аэрокосмической отраслях промышленности).



Телефон: 8 (812) 309-75-97 (многоканальный)

Факс: 8 (812) 320-03-32

Электронная почта: [ocean@oceanchips.ru](mailto:ocean@oceanchips.ru)

Web: <http://oceanchips.ru/>

Адрес: 198099, г. Санкт-Петербург, ул. Калинина, д. 2, корп. 4, лит. А