



**MCP355X**  
**Tiny Application Sensor**  
**Demo Board User's Guide**

---

**Note the following details of the code protection feature on Microchip devices:**

- Microchip products meet the specification contained in their particular Microchip Data Sheet.
- Microchip believes that its family of products is one of the most secure families of its kind on the market today, when used in the intended manner and under normal conditions.
- There are dishonest and possibly illegal methods used to breach the code protection feature. All of these methods, to our knowledge, require using the Microchip products in a manner outside the operating specifications contained in Microchip's Data Sheets. Most likely, the person doing so is engaged in theft of intellectual property.
- Microchip is willing to work with the customer who is concerned about the integrity of their code.
- Neither Microchip nor any other semiconductor manufacturer can guarantee the security of their code. Code protection does not mean that we are guaranteeing the product as "unbreakable."

Code protection is constantly evolving. We at Microchip are committed to continuously improving the code protection features of our products. Attempts to break Microchip's code protection feature may be a violation of the Digital Millennium Copyright Act. If such acts allow unauthorized access to your software or other copyrighted work, you may have a right to sue for relief under that Act.

---

Information contained in this publication regarding device applications and the like is provided only for your convenience and may be superseded by updates. It is your responsibility to ensure that your application meets with your specifications. MICROCHIP MAKES NO REPRESENTATIONS OR WARRANTIES OF ANY KIND WHETHER EXPRESS OR IMPLIED, WRITTEN OR ORAL, STATUTORY OR OTHERWISE, RELATED TO THE INFORMATION, INCLUDING BUT NOT LIMITED TO ITS CONDITION, QUALITY, PERFORMANCE, MERCHANTABILITY OR FITNESS FOR PURPOSE. Microchip disclaims all liability arising from this information and its use. Use of Microchip devices in life support and/or safety applications is entirely at the buyer's risk, and the buyer agrees to defend, indemnify and hold harmless Microchip from any and all damages, claims, suits, or expenses resulting from such use. No licenses are conveyed, implicitly or otherwise, under any Microchip intellectual property rights.

**Trademarks**

The Microchip name and logo, the Microchip logo, Accuron, dsPIC, KEELOQ, microID, MPLAB, PIC, PICmicro, PICSTART, PRO MATE, PowerSmart, rfPIC and SmartShunt are registered trademarks of Microchip Technology Incorporated in the U.S.A. and other countries.

AmpLab, FilterLab, Migratable Memory, MXDEV, MXLAB, SEEVAL, SmartSensor and The Embedded Control Solutions Company are registered trademarks of Microchip Technology Incorporated in the U.S.A.

Analog-for-the-Digital Age, Application Maestro, dsPICDEM, dsPICDEM.net, dsPICworks, ECAN, ECONOMONITOR, FanSense, FlexROM, fuzzyLAB, In-Circuit Serial Programming, ICSP, ICEPIC, Linear Active Thermistor, MPASM, MPLIB, MPLINK, MPSIM, PICkit, PICDEM, PICDEM.net, PICLAB, PICtail, PowerCal, PowerInfo, PowerMate, PowerTool, REAL ICE, rLAB, rfPICDEM, Select Mode, Smart Serial, SmartTel, Total Endurance, UNI/O, WiperLock and ZENA are trademarks of Microchip Technology Incorporated in the U.S.A. and other countries.

SQTP is a service mark of Microchip Technology Incorporated in the U.S.A.

All other trademarks mentioned herein are property of their respective companies.

© 2006, Microchip Technology Incorporated, Printed in the U.S.A., All Rights Reserved.

 Printed on recycled paper.

**QUALITY MANAGEMENT SYSTEM  
CERTIFIED BY DNV  
== ISO/TS 16949:2002 ==**

*Microchip received ISO/TS-16949:2002 certification for its worldwide headquarters, design and wafer fabrication facilities in Chandler and Tempe, Arizona, Gresham, Oregon and Mountain View, California. The Company's quality system processes and procedures are for its PICmicro® 8-bit MCUs, KEELOQ® code hopping devices, Serial EEPROMs, microperipherals, nonvolatile memory and analog products. In addition, Microchip's quality system for the design and manufacture of development systems is ISO 9001:2000 certified.*



# MCP355X TINY APPLICATION SENSOR DEMO BOARD USER'S GUIDE

---

---

## Table of Contents

---

---

<b>Preface</b> .....	<b>1</b>
Introduction.....	1
Document Layout .....	1
Conventions Used in this Guide .....	2
Recommended Reading.....	2
The Microchip Web Site .....	3
Customer Support .....	3
Document Revision History .....	3
<b>Chapter 1. Product Overview</b> .....	<b>5</b>
1.1 Introduction .....	5
1.2 What is the MCP355X Tiny Application Sensor Demo Board? .....	5
1.3 What the MCP355X Tiny Application Sensor Demo Board Kit Includes .....	5
<b>Chapter 2. Installation and Operation</b> .....	<b>7</b>
2.1 Introduction .....	7
2.2 Features .....	7
2.3 Functional Block Descriptions .....	8
<b>Appendix A. Schematic and Layouts</b> .....	<b>11</b>
A.1 Introduction .....	11
A.2 Schematics and PCB Layout .....	11
A.3 Board - Schematic .....	12
A.4 Board Layout - Top Layer .....	13
A.5 Board Layout - Bottom Layer .....	14
<b>Appendix B. Bill Of Materials (BOM)</b> .....	<b>15</b>
<b>Worldwide Sales and Service</b> .....	<b>16</b>

# **MCP355X Tiny Application Sensor Demo Board User's Guide**

---

---

NOTES:



# MCP355X TINY APPLICATION SENSOR DEMO BOARD USER'S GUIDE

---

---

## Preface

---

---

### NOTICE TO CUSTOMERS

All documentation becomes dated, and this manual is no exception. Microchip tools and documentation are constantly evolving to meet customer needs, so some actual dialogs and/or tool descriptions may differ from those in this document. Please refer to our web site ([www.microchip.com](http://www.microchip.com)) to obtain the latest documentation available.

Documents are identified with a “DS” number. This number is located on the bottom of each page, in front of the page number. The numbering convention for the DS number is “DSXXXXA”, where “XXXX” is the document number and “A” is the revision level of the document.

## INTRODUCTION

This chapter contains general information that will be useful to know before using the MCP355X Tiny Application Sensor Demo Board. Items discussed in this chapter include:

- Document Layout
- Conventions Used in this Guide
- Recommended Reading
- The Microchip Web Site
- Customer Support
- Document Revision History

## DOCUMENT LAYOUT

This document describes how to use the MCP355X Tiny Application Sensor Demo Board as a development tool to emulate and debug firmware on a target board. The manual layout is as follows:

- **Chapter 1. “Product Overview”** – This is an introduction to the MCP355X Tiny Application Sensor Demo Board. It covers the kit contents, associated tools and how they work together.
- **Chapter 2. “Installation and Operation”** – Covers the initial set-up of the MCP355X Tiny Application Sensor Demo Board. It lists the required tools, shows how to connect this board and demonstrates how to verify the set-up.
- **Appendix A. “Schematic and Layouts”** – Gives detailed information on the MCP355X Tiny Application Sensor Demo Board. Includes detailed circuit explanation, schematic, board layouts and Bill of Materials (BOM).
- **Appendix B. “Bill Of Materials (BOM)”** – Gives detailed information on the MCP355X Tiny Application Sensor Demo Board’s firmware.

# MCP355X Tiny Application Sensor Demo Board User's Guide

## CONVENTIONS USED IN THIS GUIDE

This manual uses the following documentation conventions:

### DOCUMENTATION CONVENTIONS

Description	Represents	Examples
<b>Arial font:</b>		
Italic characters	Referenced books	<i>MPLAB<sup>®</sup> IDE User's Guide</i>
	Emphasized text	...is the <i>only</i> compiler...
Initial caps	A window	the Output window
	A dialog	the Settings dialog
	A menu selection	select Enable Programmer
Quotes	A field name in a window or dialog	"Save project before build"
Underlined, italic text with right angle bracket	A menu path	<u><i>File&gt;Save</i></u>
Bold characters	A dialog button	Click <b>OK</b>
	A tab	Click the <b>Power</b> tab
N'Rnnnn	A number in verilog format, where N is the total number of digits, R is the radix and n is a digit.	4'b0010, 2'hF1
Text in angle brackets < >	A key on the keyboard	Press <Enter>, <F1>
<b>Courier New font:</b>		
Plain Courier New	Sample source code	#define START
	Filenames	autoexec.bat
	File paths	c:\mcc18\h
	Keywords	_asm, _endasm, static
	Command-line options	-Opa+, -Opa-
	Bit values	0, 1
	Constants	0xFF, 'A'
Italic Courier New	A variable argument	<i>file.o</i> , where <i>file</i> can be any valid filename
Square brackets [ ]	Optional arguments	mcc18 [options] <i>file</i> [options]
Curly brackets and pipe character: {   }	Choice of mutually exclusive arguments; an OR selection	errorlevel {0 1}
Ellipses...	Replaces repeated text	var_name [, var_name...]
	Represents code supplied by user	void main (void) { ... }

## RECOMMENDED READING

This user's guide describes how to use the MCP355X Tiny Application Sensor Demo Board. Other useful documents are listed below. The following Microchip documents are available and recommended as supplemental reference resources.

### **MCP3550/1/3 Data Sheet, "Low-Power Single Channel 22-Bit Delta-Sigma ADCs" (DS21950)**

This data sheet provides detailed information regarding the MCP355X product family.

## THE MICROCHIP WEB SITE

Microchip provides online support via our web site at [www.microchip.com](http://www.microchip.com). This web site is used as a means to make files and information easily available to customers. Accessible by using your favorite internet browser, the web site contains the following information:

- **Product Support** – Data sheets and errata, application notes and sample programs, design resources, user's guides and hardware support documents, latest software releases and archived software
- **General Technical Support** – Frequently Asked Questions (FAQs), technical support requests, online discussion groups, Microchip consultant program member listing
- **Business of Microchip** – Product selector and ordering guides, latest Microchip press releases, listing of seminars and events, listings of Microchip sales offices, distributors and factory representatives

## CUSTOMER SUPPORT

Users of Microchip products can receive assistance through several channels:

- Distributor or Representative
- Local Sales Office
- Field Application Engineer (FAE)
- Technical Support
- Development Systems Information Line

Customers should contact their distributor, representative or field application engineer for support. Local sales offices are also available to help customers. A listing of sales offices and locations is included in the back of this document.

Technical support is available through the web site at: <http://support.microchip.com>

## DOCUMENT REVISION HISTORY

### Revision A (April 2006)

- Initial Release of this Document.

# **MCP355X Tiny Application Sensor Demo Board User's Guide**

---

---

NOTES:





# MCP355X TINY APPLICATION SENSOR DEMO BOARD USER'S GUIDE

---

---

## Chapter 1. Product Overview

---

---

### 1.1 INTRODUCTION

This chapter provides an overview of the MCP355X Tiny Application Sensor Demo Board and covers the following topics:

- What is the MCP355X Tiny Application Sensor Demo Board?
- What the MCP355X Tiny Application Sensor Demo Board kit includes

### 1.2 WHAT IS THE MCP355X TINY APPLICATION SENSOR DEMO BOARD?

The MCP3550/1/3 devices are 2.7V to 5.5V low-power, 22-bit Delta-Sigma Analog-to-Digital Converters (ADCs). The MCP355X Tiny Application Sensor Demo Board is used to demonstrate the most basic application of the devices using a ratiometric connection with  $V_{DD}$  as  $V_{REF}$ . The MCP355X Tiny Application Sensor Demo Board includes all the necessary PCB circuits and PCB layout tips required to obtain the performance demonstrated on the PC.

### 1.3 WHAT THE MCP355X TINY APPLICATION SENSOR DEMO BOARD KIT INCLUDES

This MCP355X Tiny Application Sensor Demo Board Kit includes:

- The MCP355X Tiny Application Sensor Demo Board (with MCP3551 installed)
- MCP355X Tiny Application Sensor Demo Board User's Guide
- MCP3550/1/3 Data Sheet, "Low-Power Single Channel 22-Bit Delta-Sigma ADCs", (DS21950)
- AN1007 Application Note "Designing with the MCP3551 Delta-Sigma ADC", (DS01007)
- Mini-USB Cable

# **MCP355X Tiny Application Sensor Demo Board User's Guide**

---

---

NOTES:

## Chapter 2. Installation and Operation

### 2.1 INTRODUCTION

The MCP355X Tiny Application Sensor Demo Board is designed to demonstrate the performance of the MCP3550/1/3 devices in a simple low-cost application. The circuit uses a ratiometric sensor configuration and uses the system power supply as the voltage reference. The extreme common mode rejection capability of the MCP3551 device, along with its excellent normal mode power supply rejection at 50 and 60 Hz, allows for this system performance. The functional circuit block diagram is shown in Figure 2-1.

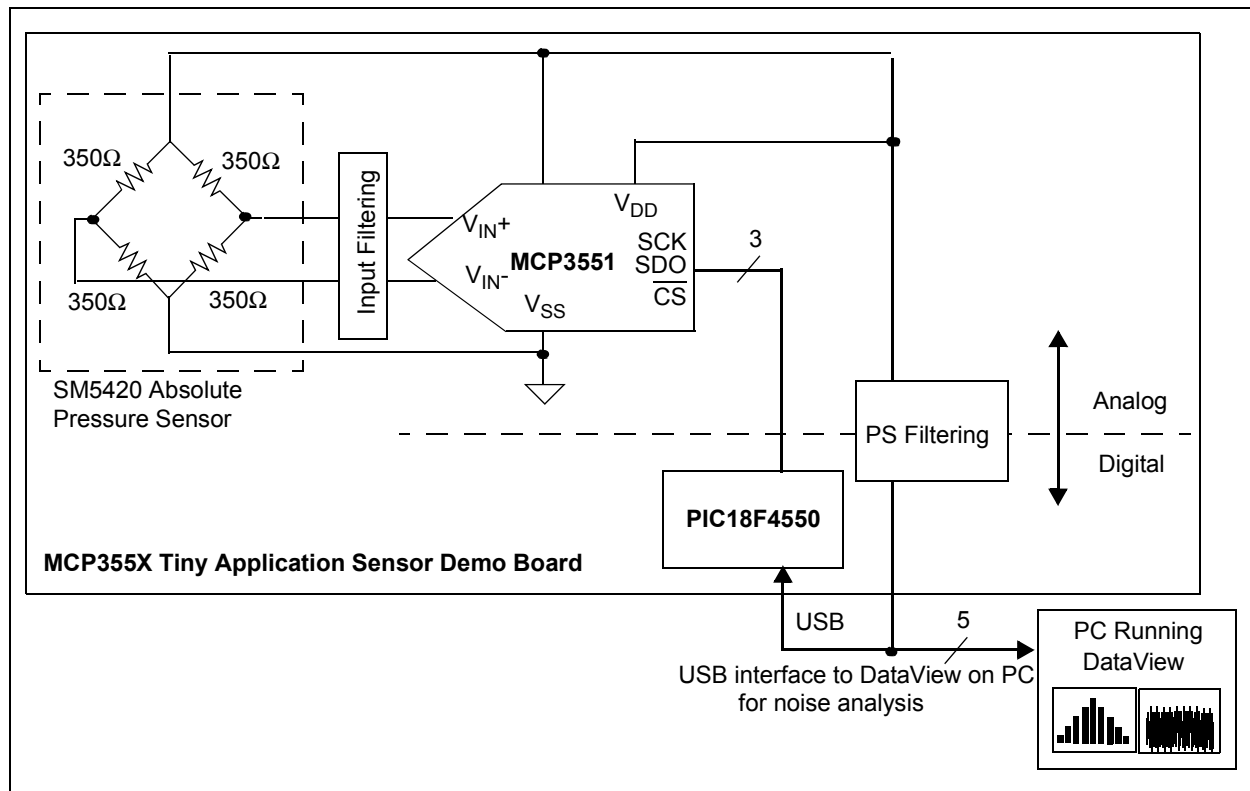

**FIGURE 2-1:** Ratiometric Sensor Configuration.

### 2.2 FEATURES

The MCP355X Tiny Application Sensor Demo Board has the following features:

- Better than 16-bit system performance from a direct connected PC USB connection using ratiometric
- Simple USB connection to DataView on the PC showing system performance
- Low-cost design for analog-to-digital conversion

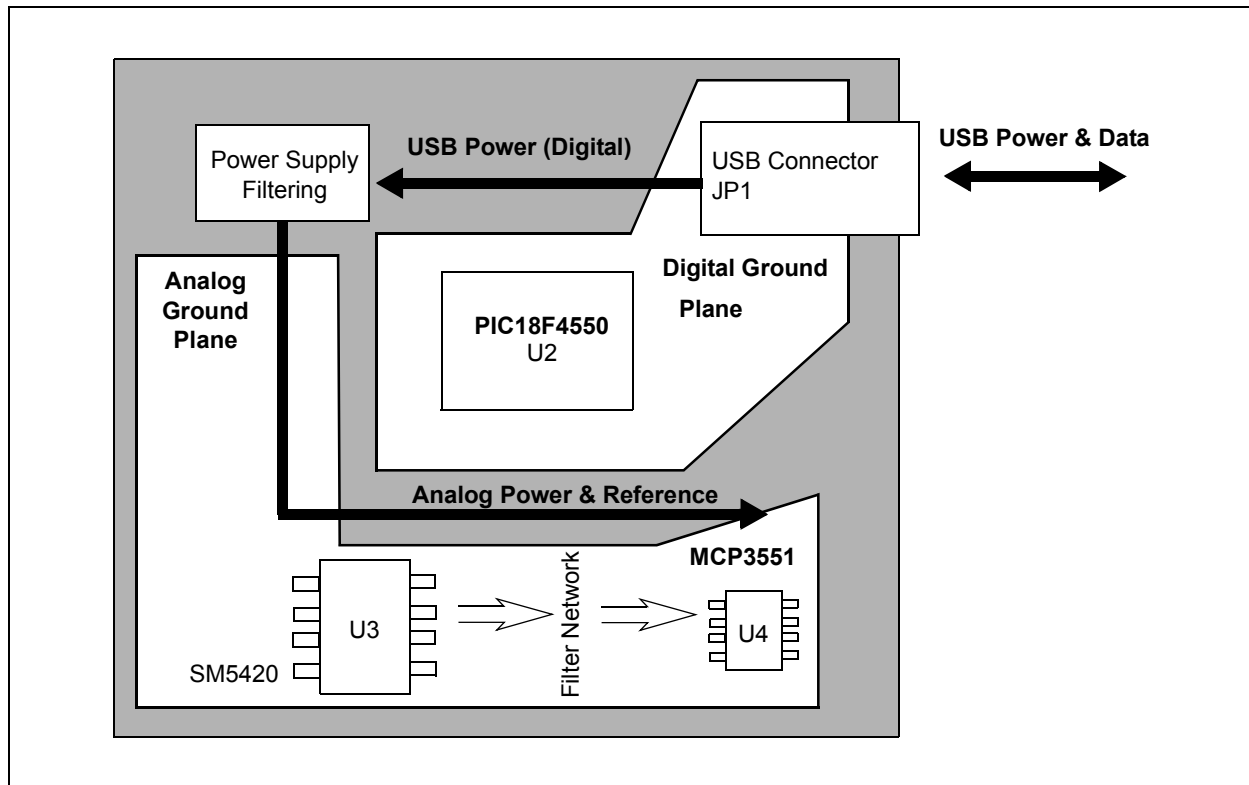

FIGURE 2-2: Block Diagram.

## 2.3 FUNCTIONAL BLOCK DESCRIPTIONS

### 2.3.1 SM5420

The SM5420 device is an absolute pressure sensor in a surface mount SOIC package. The device is a piezo resistive silicon device available from Silicon Microstructure. With a constant excitation voltage, the output changes linearly with pressure. The zero scale error of the device is rated at  $\pm 10$  mV/V and the full scale output is rated at  $60$  mV/V  $\pm 20$  mV. These large errors require an overall system calibration, as well as temperature compensation for a working absolute pressure sensor design. This board demonstrates the overall system resolution and noise performance of the ADC and sensor with no voltage reference.

### 2.3.2 MCP3551

The MCP3551 is a 22-bit Delta-Sigma A/D converter. The device includes a third-order modulator, fourth-order digital SINC filter, internal oscillator for oversampling clock and digital logic for a simple SPI interface.

#### Digital SINC Filter

The MCP3551 device includes a digital decimation filter, which is a fourth-order modified SINC filter. This filter averages the incoming bitstream from the modulator and outputs a 22-bit conversion word in binary two's complement. When all bits have been processed by the filter, the output code is ready for SPI communication, the  $\overline{RDY}$  flag is set on the SDO/ $\overline{RDY}$  pin and all the internal registers are reset in order to process the next conversion. This filter achieves greater than -80 dB of rejection at both 50 and 60 Hz. For improved performance, the MCP3550 device is available which gives greater than -120 dB of rejection at either 50 or 60 Hz.

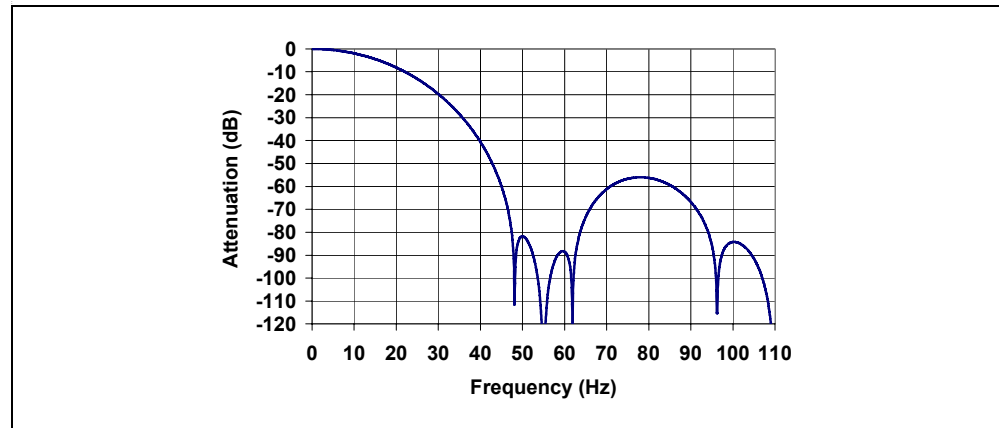

**FIGURE 2-3:** SINC filter response, MCP3551 device, simultaneous 50/60 Hz Normal Mode Rejection.

### 2.3.3 PIC18F4550

The high speed USB PICmicro<sup>®</sup> microcontroller is used to connect to the PC and quickly evaluate system performance. An In-Circuit Serial Programming<sup>™</sup> (ICSP<sup>™</sup>) connector is also included.

### 2.3.4 Filtering

Power supply filtering using passive components is included to improve the noise performance of the MCP3551 device. The following circuit comprises the filtering on the power supply, separating the analog and digital sections of the board:

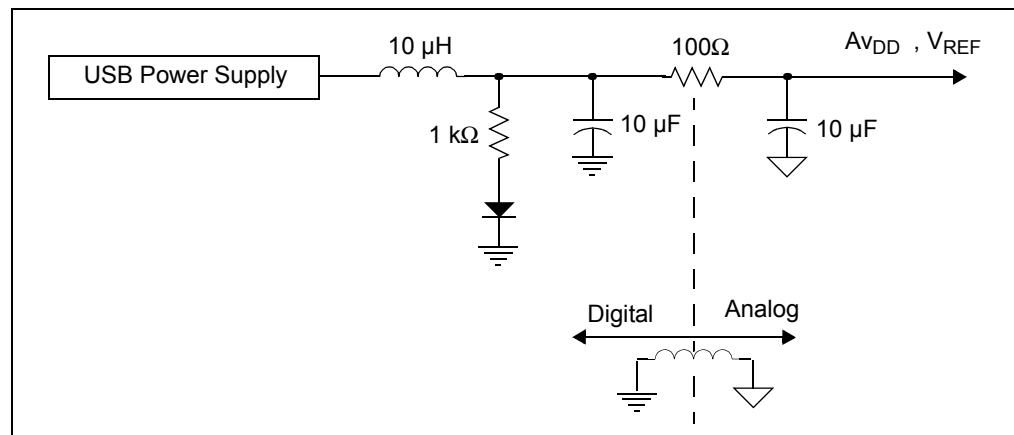

### 2.3.5 DataView Noise Analysis

The system noise from the MCP355X Tiny Application Sensor Demo Board will be an aperiodic signal not having any wave or shape. This randomness is best dealt with in statistical properties, hence the RMS measurement of the Gaussian or normal distribution. When designing a system and attempting to measure the performance, the RMS noise is much more repeatable than the peak-to-peak noise. Figure 2-4 shows two different distributions with different RMS and PEAK values, representing two different ADC output distributions.

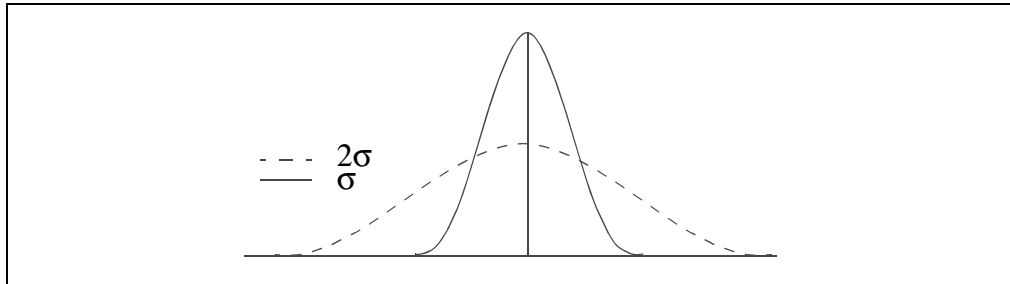

**FIGURE 2-4:** Two Normal or Gaussian Output Distributions.

The DataView software tool is a visualization tool, showing real-time histograms using the MCP3551. The software also calculates the RMS noise of the current distribution. The number of samples in the distribution is also scalable, allowing post averaging experiments.

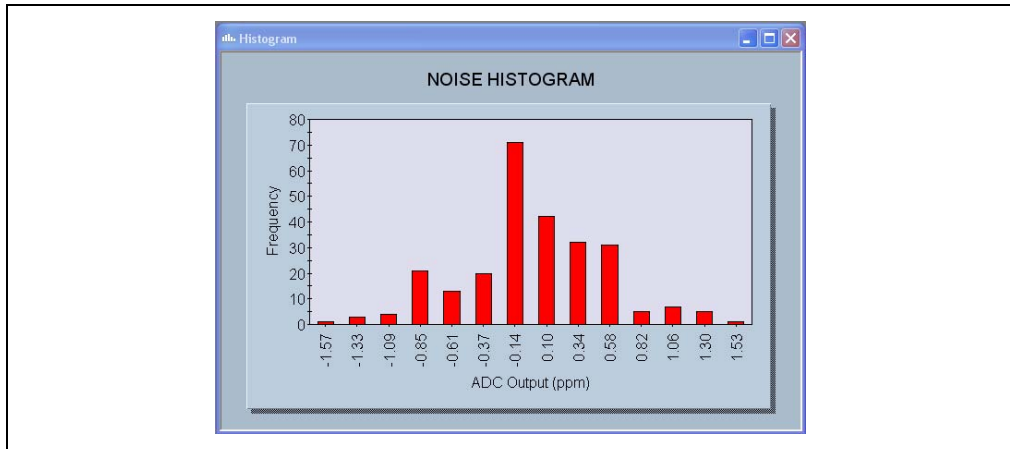

**FIGURE 2-5:** DataView showing system performance in a histogram format.

The software can also be used for time-based system analysis using the scope plot window. Any system drift or other time-based errors can be analyzed using this visual analysis tool.

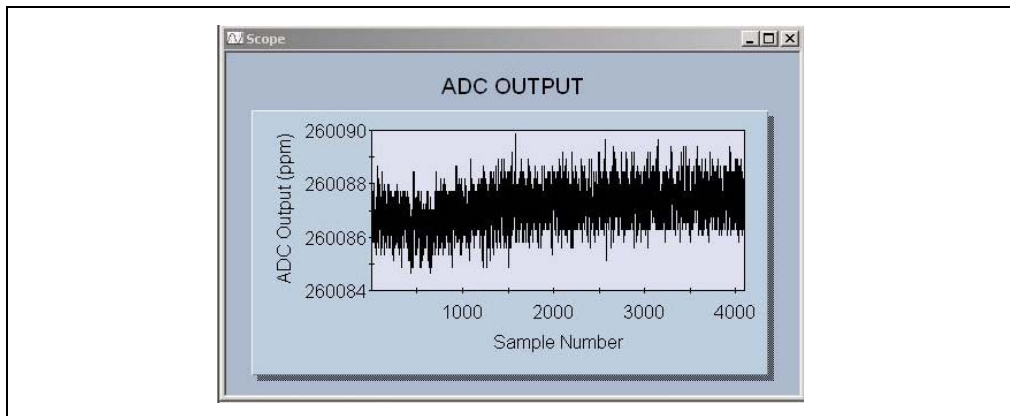

**FIGURE 2-6:** DataView Scope Plot View.

---

---

## **Appendix A. Schematic and Layouts**

---

---

### **A.1 INTRODUCTION**

This appendix contains the following schematics and layouts for the MCP355X Tiny Application Sensor Demo Board User's Guide:

- Board Schematic
- Board - Top Layer
- Board - Bottom Layer

### **A.2 SCHEMATICS AND PCB LAYOUT**

**Figure A.3 "Board - Schematic"** shows the MCP355X Tiny Application Sensor Demo Board schematic, while **Figure A.4 "Board Layout - Top Layer"** and **Figure A.5 "Board Layout - Bottom Layer"** show the layout for the two different layers. The layer order is shown in Figure A-1.

**FIGURE A-1: LAYER ORDER**

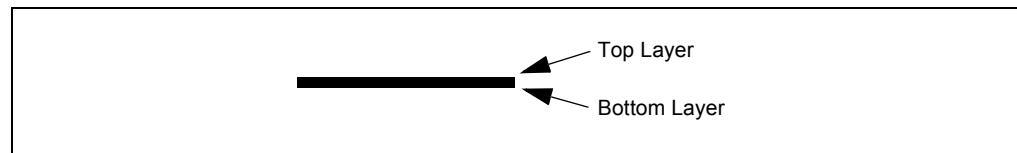

# MCP355X Tiny Application Sensor Demo Board User's Guide

## A.3 BOARD - SCHEMATIC

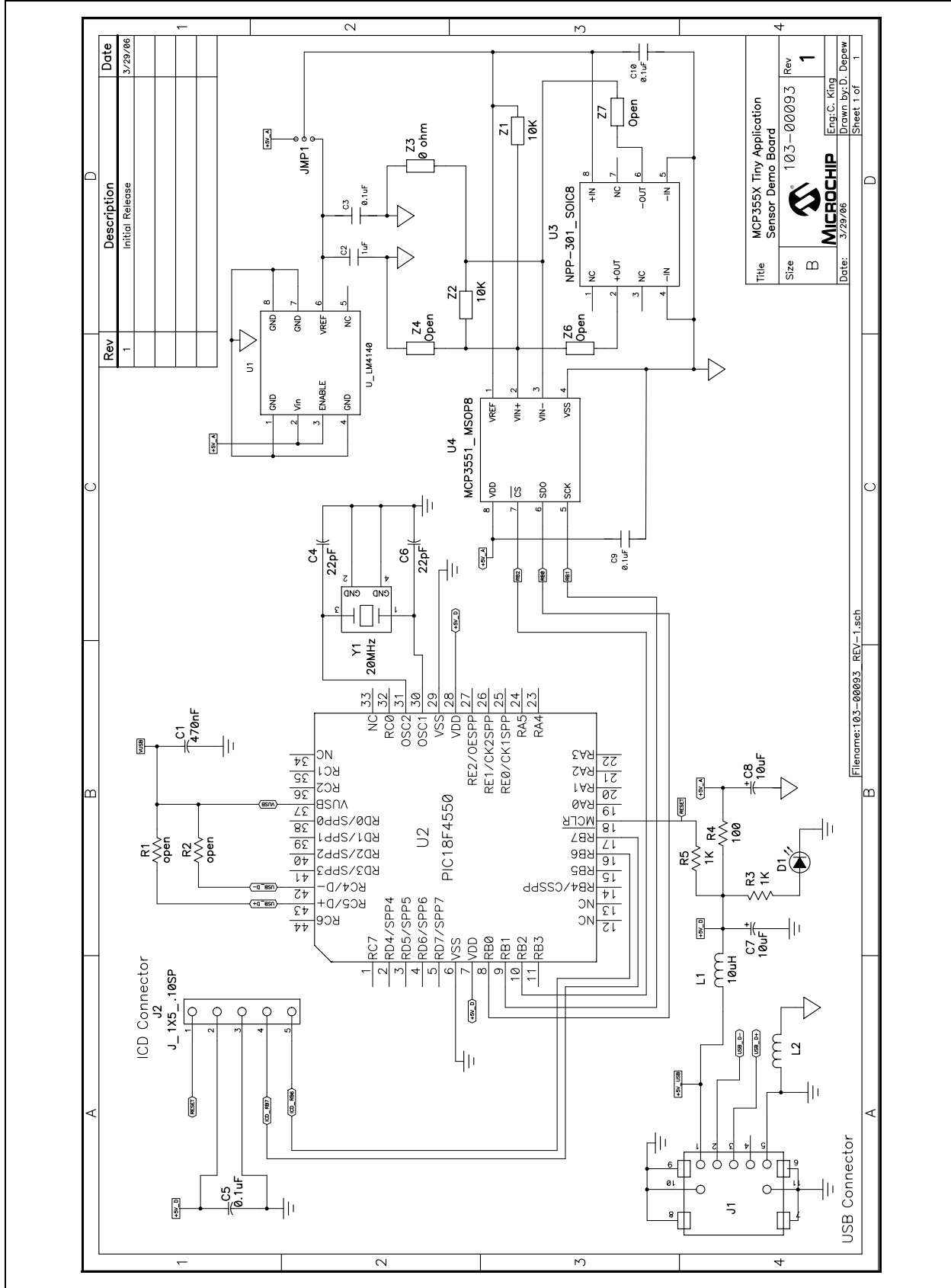



## A.4 BOARD LAYOUT - TOP LAYER

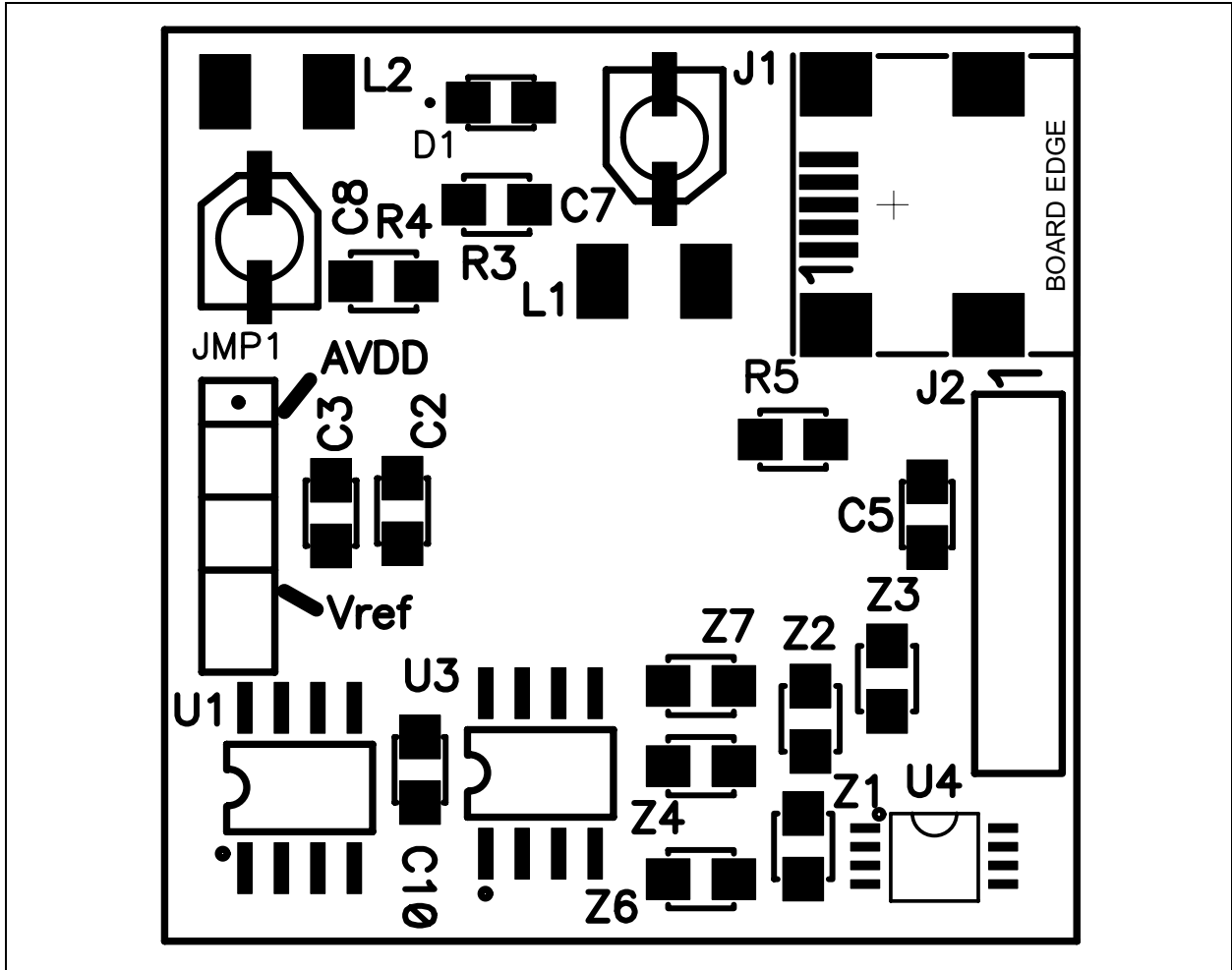

A.5 BOARD LAYOUT - BOTTOM LAYER

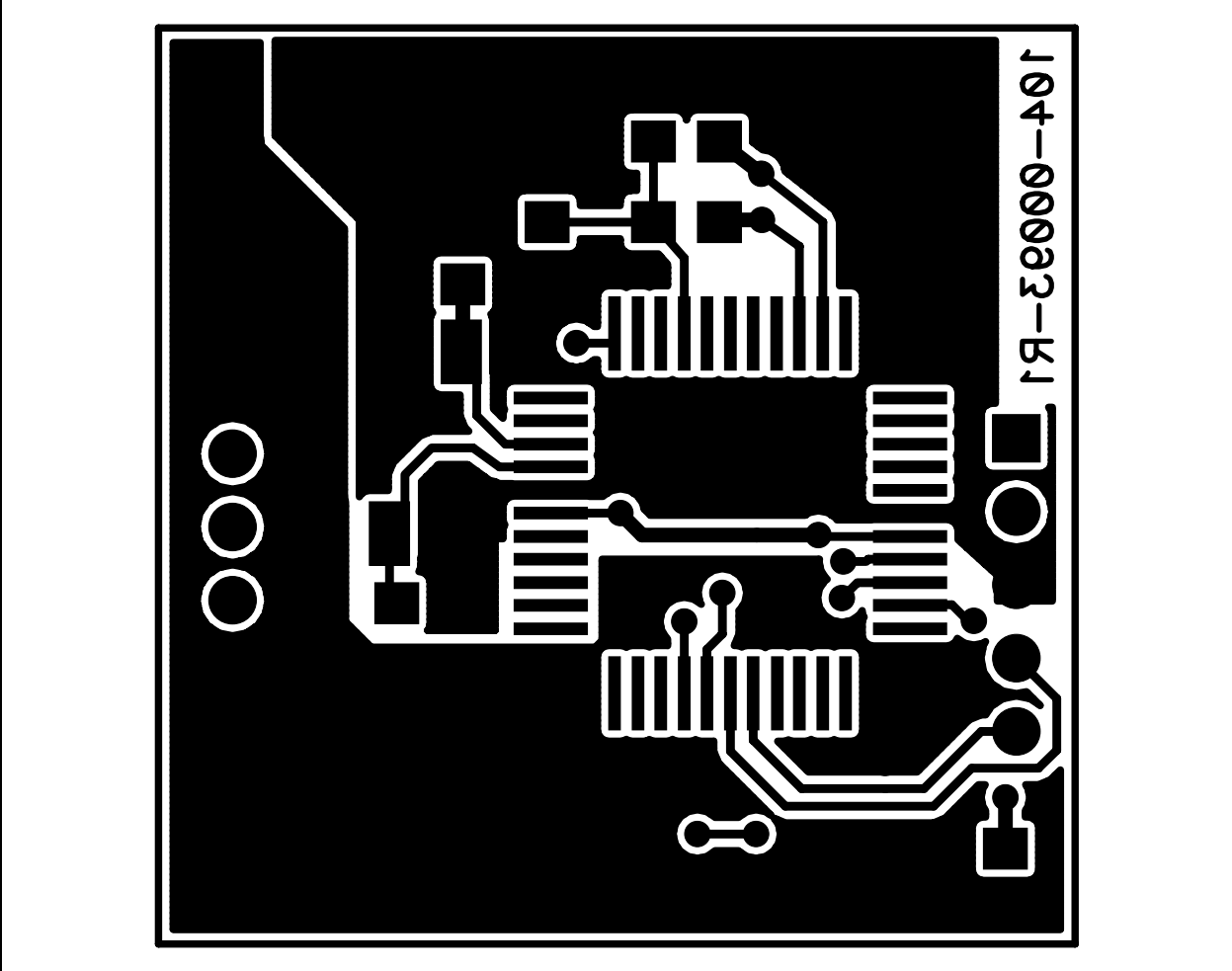



# MCP355X TINY APPLICATION SENSOR DEMO BOARD USER'S GUIDE

## Appendix B. Bill Of Materials (BOM)

**TABLE B-1: BILL OF MATERIALS (BOM)**

Qty	Reference	Description	Manufacturer	Part Number
1	C1	CAP .47UF 16V CERAMIC X7R 0805	Panasonic® - ECG	ECJ-2YB1C474K
1	C2	CAP 1.0UF 10V CERAMIC X7R 0805	Kemet® Electronics	C0805C105K8RACTU
3	C3, C9, C10	CAP .1UF 25V CERAMIC X7R 0805	Panasonic - ECG	ECJ-2VB1E104K
2	C4, C6	CAP 22PF 50V CERM CHIP 0805 SMD	Panasonic - ECG	ECJ-2VC1H220J
1	C5	CAP .1UF 25V CERAMIC X7R 0805	Panasonic - ECG	ECJ-2VB1E104K
2	C7, C8	10uF/16V CAP-SMT-ELCTRO	Panasonic - ECG	EEE-1CA100SR
1	D1	LED RED CLEAR 0805 SMD	Lite-On Trading USA Inc	LTST-C170CKT
1	J1	CONN RECEPT MINI USB2.0 5POS	Hirose Electronic Co. Ltd	UX60-MB-5ST
1	J2	HEADER,.1""ST MALE,1RW,6PIN,(10) .025""PST,.23GOLDTAIL	Value-Pro	JS1109-6-R
1	JMP1	3PIN, .100" Straight Male Headers (Gold)	Value-Pro	7000-1X3SG-R
1	JMP1 Shunt	SHUNT LP W/HANDLE 2 POS 30AU	AMP®/Tyco® Electronics	881545-2
2	JP1, JP2	NOT INSTALLED	-	-
2	L1, L2	FERRITE 500MA 600 OHM 0805 SMD	Steward® Inc.	HZ0805E601R-10
1	PCB	RoHS Compliant Bare PCB, MCP355X Tiny Application Sensor Demo Board.	-	104-00093
2	R1, R2	NOT INSTALLED	Open	RES0805
1	R3	RES 1.00K OHM 1/10W 1% 0805 SMD	Panasonic - ECG	ERJ-6ENF1001V
1	R4	RES 100 OHM 1/10W 1% 0805 SMD	Panasonic - ECG	ERJ-6ENF1000V
1	U1	LM4140 IC VOLT REF PREC MICROPWR 8-SOIC	National Semiconductor®	LM4140CCM-4.1/NOPB
1	U2	PIC18F4550	Microchip Technology	PIC18F4550-I/PT
1	U3	SM5420 is an SO-8 packaged 15 PSI pressure sensor.	Silicon Microstructures, Inc.	SM5420-015-A-H-T
1	U4	MCP3551_MSOP	Microchip Technology	MCP3551-E/MS
1	Y1	CRYSTAL 20MHZ METAL CASE SMD	Connor-Winfield	XM-1-20.0000
2	Z1, Z2	RES 10.0K OHM 1/10W 1% 0805 SMD	Panasonic - ECG	ERJ-6ENF1002V
1	Z3	RES 0.0 OHM 1/8W 5% 0805 SMD	Panasonic - ECG	ERJ-6GEY0R00V
3	Z4, Z6, Z7	NOT INSTALLED	Open	RES0805_MCHIP



---

## WORLDWIDE SALES AND SERVICE

---

### AMERICAS

#### Corporate Office

2355 West Chandler Blvd.  
Chandler, AZ 85224-6199  
Tel: 480-792-7200  
Fax: 480-792-7277  
Technical Support:  
<http://support.microchip.com>  
Web Address:  
[www.microchip.com](http://www.microchip.com)

#### Atlanta

Alpharetta, GA  
Tel: 770-640-0034  
Fax: 770-640-0307

#### Boston

Westborough, MA  
Tel: 774-760-0087  
Fax: 774-760-0088

#### Chicago

Itasca, IL  
Tel: 630-285-0071  
Fax: 630-285-0075

#### Dallas

Addison, TX  
Tel: 972-818-7423  
Fax: 972-818-2924

#### Detroit

Farmington Hills, MI  
Tel: 248-538-2250  
Fax: 248-538-2260

#### Kokomo

Kokomo, IN  
Tel: 765-864-8360  
Fax: 765-864-8387

#### Los Angeles

Mission Viejo, CA  
Tel: 949-462-9523  
Fax: 949-462-9608

#### San Jose

Mountain View, CA  
Tel: 650-215-1444  
Fax: 650-961-0286

#### Toronto

Mississauga, Ontario,  
Canada  
Tel: 905-673-0699  
Fax: 905-673-6509

### ASIA/PACIFIC

#### Australia - Sydney

Tel: 61-2-9868-6733  
Fax: 61-2-9868-6755

#### China - Beijing

Tel: 86-10-8528-2100  
Fax: 86-10-8528-2104

#### China - Chengdu

Tel: 86-28-8676-6200  
Fax: 86-28-8676-6599

#### China - Fuzhou

Tel: 86-591-8750-3506  
Fax: 86-591-8750-3521

#### China - Hong Kong SAR

Tel: 852-2401-1200  
Fax: 852-2401-3431

#### China - Qingdao

Tel: 86-532-8502-7355  
Fax: 86-532-8502-7205

#### China - Shanghai

Tel: 86-21-5407-5533  
Fax: 86-21-5407-5066

#### China - Shenyang

Tel: 86-24-2334-2829  
Fax: 86-24-2334-2393

#### China - Shenzhen

Tel: 86-755-8203-2660  
Fax: 86-755-8203-1760

#### China - Shunde

Tel: 86-757-2839-5507  
Fax: 86-757-2839-5571

#### China - Wuhan

Tel: 86-27-5980-5300  
Fax: 86-27-5980-5118

#### China - Xian

Tel: 86-29-8833-7250  
Fax: 86-29-8833-7256

### ASIA/PACIFIC

#### India - Bangalore

Tel: 91-80-4182-8400  
Fax: 91-80-4182-8422

#### India - New Delhi

Tel: 91-11-5160-8631  
Fax: 91-11-5160-8632

#### India - Pune

Tel: 91-20-2566-1512  
Fax: 91-20-2566-1513

#### Japan - Yokohama

Tel: 81-45-471-6166  
Fax: 81-45-471-6122

#### Korea - Gumi

Tel: 82-54-473-4301  
Fax: 82-54-473-4302

#### Korea - Seoul

Tel: 82-2-554-7200  
Fax: 82-2-558-5932 or  
82-2-558-5934

#### Malaysia - Penang

Tel: 60-4-646-8870  
Fax: 60-4-646-5086

#### Philippines - Manila

Tel: 63-2-634-9065  
Fax: 63-2-634-9069

#### Singapore

Tel: 65-6334-8870  
Fax: 65-6334-8850

#### Taiwan - Hsin Chu

Tel: 886-3-572-9526  
Fax: 886-3-572-6459

#### Taiwan - Kaohsiung

Tel: 886-7-536-4818  
Fax: 886-7-536-4803

#### Taiwan - Taipei

Tel: 886-2-2500-6610  
Fax: 886-2-2508-0102

#### Thailand - Bangkok

Tel: 66-2-694-1351  
Fax: 66-2-694-1350

### EUROPE

#### Austria - Wels

Tel: 43-7242-2244-399  
Fax: 43-7242-2244-393

#### Denmark - Copenhagen

Tel: 45-4450-2828  
Fax: 45-4485-2829

#### France - Paris

Tel: 33-1-69-53-63-20  
Fax: 33-1-69-30-90-79

#### Germany - Munich

Tel: 49-89-627-144-0  
Fax: 49-89-627-144-44

#### Italy - Milan

Tel: 39-0331-742611  
Fax: 39-0331-466781

#### Netherlands - Drunen

Tel: 31-416-690399  
Fax: 31-416-690340

#### Spain - Madrid

Tel: 34-91-708-08-90  
Fax: 34-91-708-08-91

#### UK - Wokingham

Tel: 44-118-921-5869  
Fax: 44-118-921-5820

Компания «Океан Электроники» предлагает заключение долгосрочных отношений при поставках импортных электронных компонентов на взаимовыгодных условиях!

Наши преимущества:

- Поставка оригинальных импортных электронных компонентов напрямую с производств Америки, Европы и Азии, а так же с крупнейших складов мира;
- Широкая линейка поставок активных и пассивных импортных электронных компонентов (более 30 млн. наименований);
- Поставка сложных, дефицитных, либо снятых с производства позиций;
- Оперативные сроки поставки под заказ (от 5 рабочих дней);
- Экспресс доставка в любую точку России;
- Помощь Конструкторского Отдела и консультации квалифицированных инженеров;
- Техническая поддержка проекта, помощь в подборе аналогов, поставка прототипов;
- Поставка электронных компонентов под контролем ВП;
- Система менеджмента качества сертифицирована по Международному стандарту ISO 9001;
- При необходимости вся продукция военного и аэрокосмического назначения проходит испытания и сертификацию в лаборатории (по согласованию с заказчиком);
- Поставка специализированных компонентов военного и аэрокосмического уровня качества (Xilinx, Altera, Analog Devices, Intersil, Interpoint, Microsemi, Actel, Aeroflex, Peregrine, VPT, Syfer, Eurofarad, Texas Instruments, MS Kennedy, Miteq, Cobham, E2V, MA-COM, Hittite, Mini-Circuits, General Dynamics и др.);

Компания «Океан Электроники» является официальным дистрибьютором и эксклюзивным представителем в России одного из крупнейших производителей разъемов военного и аэрокосмического назначения «JONHON», а так же официальным дистрибьютором и эксклюзивным представителем в России производителя высокотехнологичных и надежных решений для передачи СВЧ сигналов «FORSTAR».



## JONHON

«JONHON» (основан в 1970 г.)

Разъемы специального, военного и аэрокосмического назначения:

(Применяются в военной, авиационной, аэрокосмической, морской, железнодорожной, горно- и нефтедобывающей отраслях промышленности)

«FORSTAR» (основан в 1998 г.)

ВЧ соединители, коаксиальные кабели, кабельные сборки и микроволновые компоненты:

(Применяются в телекоммуникациях гражданского и специального назначения, в средствах связи, РЛС, а так же военной, авиационной и аэрокосмической отраслях промышленности).



Телефон: 8 (812) 309-75-97 (многоканальный)

Факс: 8 (812) 320-03-32

Электронная почта: [ocean@oceanchips.ru](mailto:ocean@oceanchips.ru)

Web: <http://oceanchips.ru/>

Адрес: 198099, г. Санкт-Петербург, ул. Калинина, д. 2, корп. 4, лит. А