

80 watt + 80 watt dual BTL class-D audio amplifier

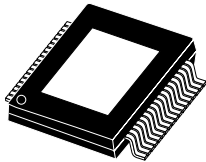

**PowerSSO-36
exposed pad up**

Features

- 80 W + 80 W output power at THD = 10% with $R_L = 6 \Omega$ and $V_{CC} = 32 V$
- 70 W + 70 W output power at THD = 10% with $R_L = 8 \Omega$ and $V_{CC} = 34 V$
- Wide-range single-supply operation (14 - 36 V)
- High efficiency ($\eta = 90\%$)
- Four selectable, fixed gain settings of nominally 25.6 dB, 31.6 dB, 35.1 dB and 37.6 dB
- Differential inputs minimize common-mode noise
- Standby and mute features
- Short-circuit protection
- Thermal overload protection
- Externally synchronizable

Description

The **TDA7498L** is a dual BTL class-D audio amplifier with single power supply designed for home systems and active speaker applications.

It comes in a 36-pin PowerSSO package with exposed pad up (EPU) to facilitate mounting a separate heatsink.

| Product status link | |
|--------------------------|------------------|
| TDA7498L | |
| Product summary | |
| Order code | TDA7498LTR |
| Temperature range | -40 to 85 °C |
| Package | PowerSSO36 (EPU) |
| Packing | Tape and reel |

1 Device block diagram

Figure 1. Internal block diagram (showing one channel only) shows the block diagram of one of the two identical channels of the TDA7498L.

Figure 1. Internal block diagram (showing one channel only)

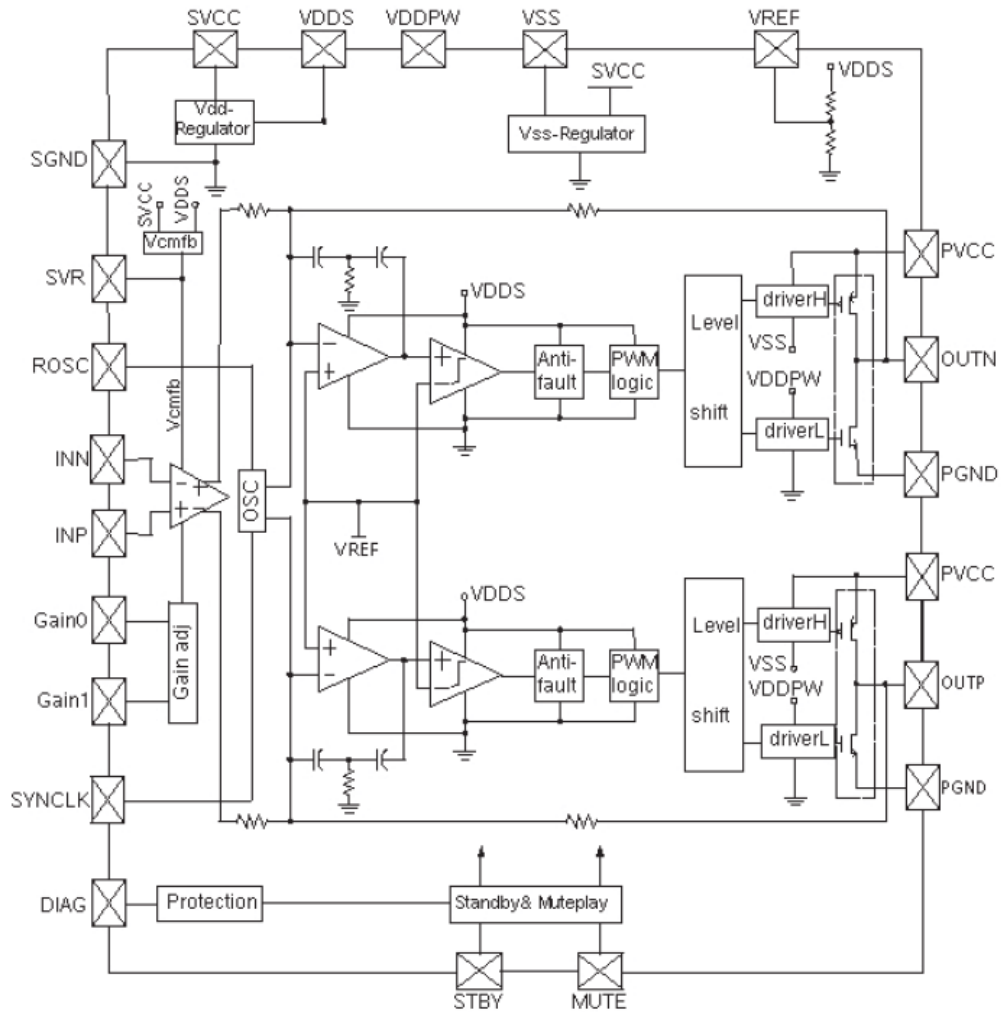

2 Pin description

2.1 Pinout

Figure 2. Pin connections (top view, PCB view)

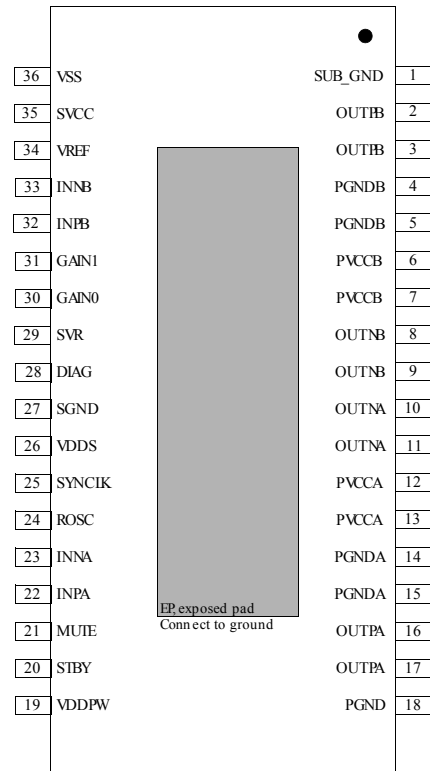

2.2 Pin list

Table 1. Pin description list

| Number | Name | Type | Description |
|--------|---------|------|---|
| 1 | SUB_GND | PWR | Connect to the frame |
| 2,3 | OUTPB | O | Positive PWM for right channel |
| 4,5 | PGNDB | PWR | Power stage ground for right channel |
| 6,7 | PVCCB | PWR | Power supply for right channel |
| 8,9 | OUTNB | O | Negative PWM output for right channel |
| 10,11 | OUTNA | O | Negative PWM output for left channel |
| 12,13 | PVCCA | PWR | Power supply for left channel |
| 14,15 | PGNDA | PWR | Power stage ground for left channel |
| 16,17 | OUTPA | O | Positive PWM output for left channel |
| 18 | PGND | PWR | Power stage ground |
| 19 | VDDPW | O | 3.3-V (nominal) regulator output referred to ground for power stage |
| 20 | STBY | I | Standby mode control |
| 21 | MUTE | I | Mute mode control |
| 22 | INPA | I | Positive differential input of left channel |
| 23 | INNA | I | Negative differential input of left channel |
| 24 | ROSC | O | Master oscillator frequency-setting pin |
| 25 | SYNCLK | I/O | Clock in/out for external oscillator |
| 26 | VDDS | O | 3.3-V (nominal) regulator output referred to ground for signal blocks |
| 27 | SGND | PWR | Signal ground |
| 28 | DIAG | O | Open-drain diagnostic output |
| 29 | SVR | O | Supply voltage rejection |
| 30 | GAIN0 | I | Gain setting input 1 |
| 31 | GAIN1 | I | Gain setting input 2 |
| 32 | INPB | I | Positive differential input of right channel |
| 33 | INNB | I | Negative differential input of right channel |
| 34 | VREF | O | Half VDDS (nominal) referred to ground |
| 35 | SVCC | PWR | Signal power supply decoupling |
| 36 | VSS | O | 3.3-V (nominal) regulator output referred to power supply |
| - | EP | - | Exposed pad for heatsink, to be connected to ground |

3 Electrical specifications

3.1 Absolute maximum ratings

Table 2. Absolute maximum ratings

| Symbol | Parameter | Value | Unit |
|---------------------|--|-------------|------|
| V _{CC_MAX} | DC supply voltage for pins PVCCA, PVCCB, SVCC | 45 | V |
| V _{L_MAX} | Voltage limits for input pins STBY, MUTE, INNA, INPA, INNB, INPB, GAIN0, GAIN1 | -0.3 to 3.6 | V |
| T _{j_MAX} | Operating junction temperature | 0 to 150 | °C |
| T _{stg} | Storage temperature | -40 to 150 | °C |

Note: *warning: stresses beyond those listed under “Absolute maximum ratings” make cause permanent damage to the device. These are stress ratings only, and functional operation of the device at these or any other conditions beyond those indicated under “Recommended operating condition” are not implied. Exposure to absolute maximum rated conditions for extended periods may affect device reliability. In the real application, the power supply with the nominal value rated in the recommended operating conditions may rise beyond the maximum operating condition for a short time when no or very low current is sunk (amplifier in mute state). In this case the reliability of the device is guaranteed, provided that the absolute maximum rating is not exceeded.*

3.2 Thermal data

Table 3. Thermal data

| Symbol | Parameter | Min. | Typ. | Max. | Unit |
|------------------------|--------------------------------------|------|------|------|------|
| R _{th j-case} | Thermal resistance, junction to case | - | 2 | 3 | °C/W |

3.3 Recommended operating conditions

Table 4. Recommended operating conditions

| Symbol | Parameter | Min. | Typ. | Max. | Unit |
|------------------|--------------------------------------|------|------|------|------|
| V _{CC} | Supply voltage for pins PVCCA, PVCCB | 14 | - | 36 | V |
| T _{amb} | Ambient operating temperature | -20 | - | 85 | °C |

3.4 Electrical characteristics

Unless otherwise stated, the values in the table below are specified for the conditions: $V_{CC} = 32\text{ V}$, $R_L = 6\ \Omega$, $R_{OSC} = R_3 = 39\text{ k}\Omega$, $C_8 = 100\text{ nF}$, $f = 1\text{ kHz}$, $G_V = 25.6\text{ dB}$, $T_{amb} = 25\text{ }^\circ\text{C}$.

Table 5. Electrical characteristics

| Symbol | Parameter | Test conditions | Min. | Typ. | Max. | Unit |
|--------------|--|---|------|------|------|------------------|
| I_q | Total quiescent current | No LC filter, no load | - | 40 | 60 | mA |
| I_{qSTBY} | Quiescent current in standby | - | - | 1 | 10 | μA |
| V_{OS} | Output offset voltage | Play mode | -100 | - | 100 | mV |
| | | Mute mode | -60 | - | 60 | |
| I_{OCP} | Overcurrent protection threshold | $R_L = 0\ \Omega$ | 5.0 | 6.0 | - | A |
| T_{JS} | Junction temperature at thermal shutdown | - | - | 150 | - | $^\circ\text{C}$ |
| R_i | Input resistance | Differential input | 48 | 60 | - | k Ω |
| V_{OVP} | Overvoltage protection threshold | - | 42 | 43 | - | V |
| V_{UVP} | Undervoltage protection threshold | - | - | - | 8 | V |
| R_{dsON} | Power transistor on-resistance | High side | - | 0.2 | - | Ω |
| | | Low side | - | 0.2 | - | |
| P_o | Output power | THD = 10% | - | 80 | - | W |
| | | THD = 1% | - | 65 | - | |
| P_o | Output power | $R_L = 8\ \Omega$, THD = 10%, $V_{CC} = 32\text{ V}$ | - | 65 | - | W |
| P_D | Dissipated power | $P_o = 80\text{ W} + 80\text{ W}$, THD = 10% | - | 16 | - | W |
| η | Efficiency | $P_o = 80\text{ W} + 80\text{ W}$ | - | 90 | - | % |
| THD | Total harmonic distortion | $P_o = 1\text{ W}$ | - | 0.1 | - | % |
| G_V | Closed-loop gain | GAIN0 = L, GAIN1 = L | 24.6 | 25.6 | 26.6 | dB |
| | | GAIN0 = L, GAIN1 = H | 30.6 | 31.6 | 32.6 | |
| | | GAIN0 = H, GAIN1 = L | 34.1 | 35.1 | 36.1 | |
| | | GAIN0 = H, GAIN1 = H | 36.6 | 37.6 | 38.6 | |
| ΔG_V | Gain matching | - | -1 | - | 1 | dB |
| C_T | Crosstalk | $f = 1\text{ kHz}$, $P_o = 1\text{ W}$ | 50 | 70 | - | dB |
| e_N | Total input noise | A Curve, $G_V = 20\text{ dB}$ | - | 15 | - | μV |
| | | $f = 22\text{ Hz to } 22\text{ kHz}$ | - | 25 | 50 | |
| SVRR | Supply voltage rejection ratio | $f_r = 100\text{ Hz}$, $V_r = 0.5\text{ Vpp}$, $C_{SVR} = 10\ \mu\text{F}$ | - | 70 | - | dB |
| T_r, T_f | Rise and fall times | - | - | 50 | - | ns |
| f_{SW} | Switching frequency | Internal oscillator | 290 | 310 | 330 | kHz |
| f_{SWR} | Output switching frequency range | With internal oscillator ⁽¹⁾ | 250 | - | 400 | kHz |
| | | With external oscillator ⁽²⁾ | 250 | - | 400 | |
| V_{inH} | Digital input high (H) | - | 2.3 | - | - | V |
| V_{inL} | Digital input low (L) | - | - | - | 0.8 | |

| Symbol | Parameter | Test conditions | Min. | Typ. | Max. | Unit |
|-------------------|---------------------------|---------------------------|------|------|------|------|
| V _{STBY} | Pin STBY voltage high (H) | - | 2.7 | - | - | V |
| | Pin STBY voltage low (L) | | - | - | 0.5 | |
| V _{MUTE} | Pin MUTE voltage high (H) | - | 2.5 | - | - | V |
| | Pin MUTE voltage low (L) | | - | - | 0.8 | |
| A _{MUTE} | Mute attenuation | V _{MUTE} < 0.8 V | - | 70 | - | dB |

1. $f_{SW} = 10^6 / ((16 * R_{OSC} + 182) * 4)$ kHz, $f_{SYNCLK} = 2 * f_{SW}$ with $R3 = 39$ k Ω (see [Figure 20. Application circuit](#)).

2. $f_{SW} = f_{SYNCLK} / 2$ with the external oscillator.

4 Characterization curves

Figure 20. Application circuit shows the test circuit with which the characterization curves, shown in the next sections, were measured. Figure 3. Test board below shows the PCB layout.

4.1 PCB layout

Figure 3. Test board

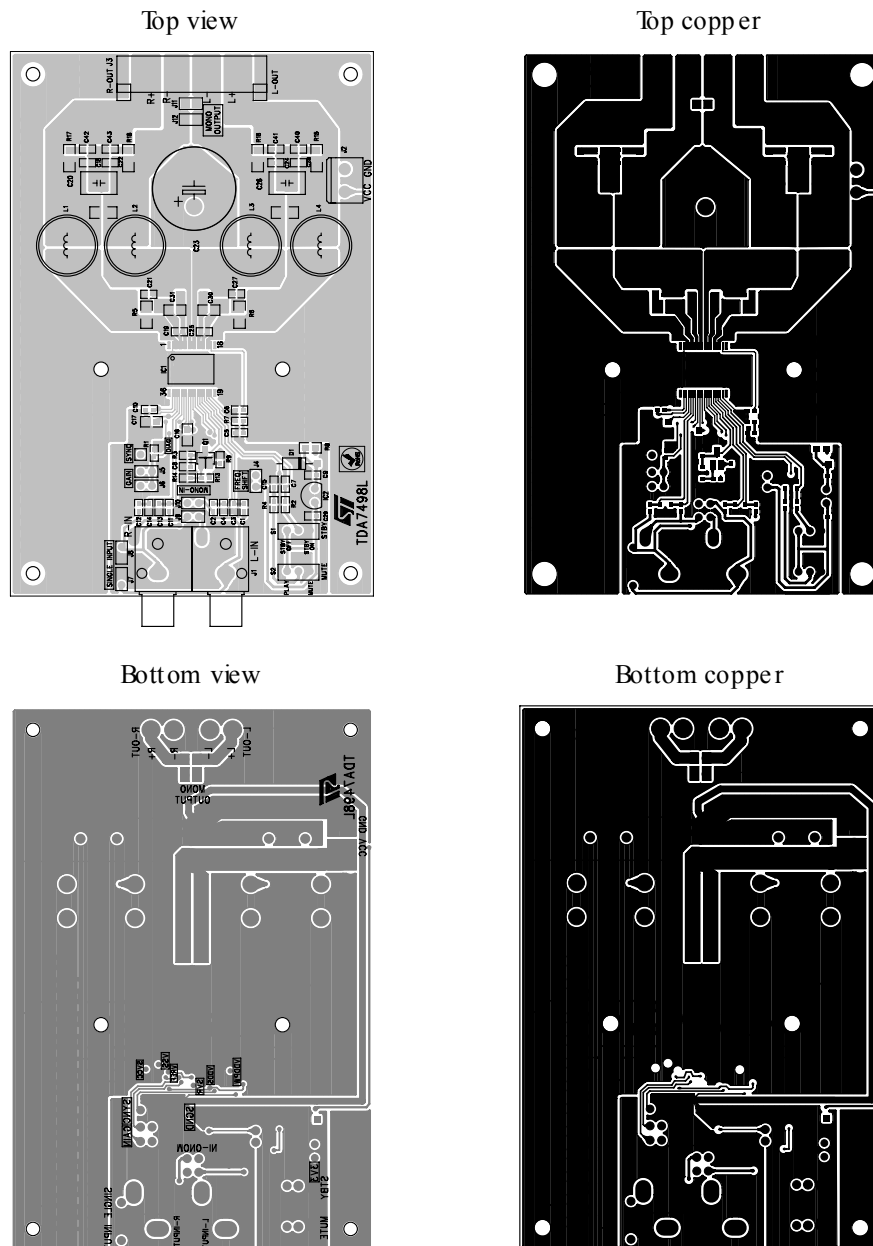

4.2 Characterization curves

Unless otherwise stated the measurements were made under the following conditions:

$V_{CC} = 32\text{ V}$, $f = 1\text{ kHz}$, $G_V = 25.6\text{ dB}$, $R_{OSC} = 39\text{ k}\Omega$, $C_{OSC} = 100\text{ nF}$, $T_{amb} = 25\text{ }^\circ\text{C}$

4.2.1 For $R_L = 6\text{ }\Omega$

Figure 4. Output power vs. supply voltage

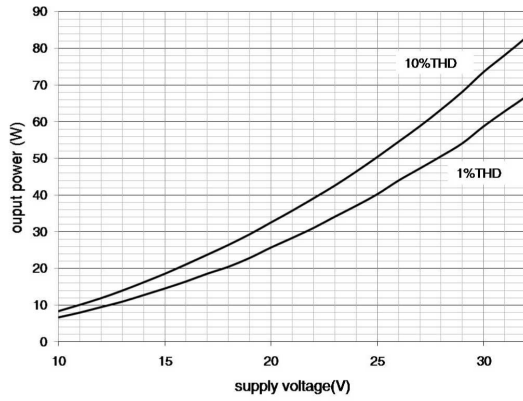

Figure 5. THD vs. output power (1 kHz)

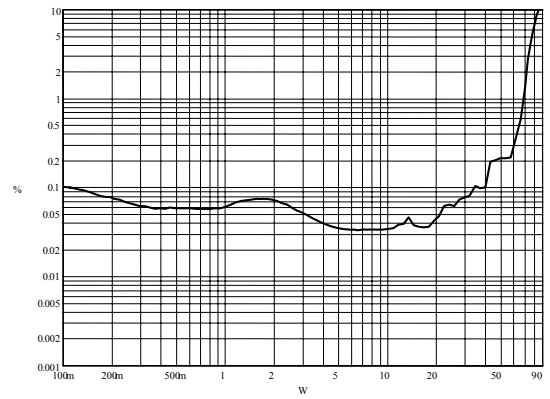

Figure 6. THD vs. output power (100 Hz)

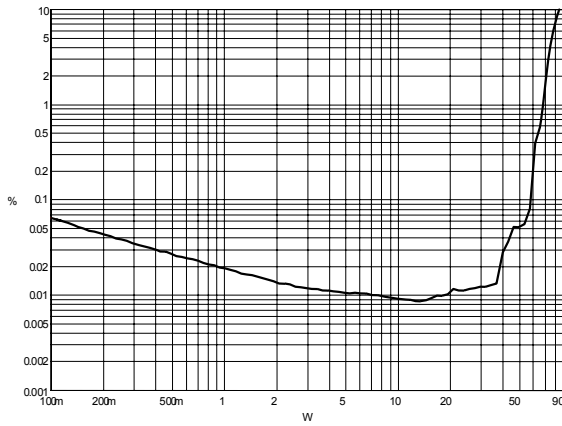

Figure 7. THD vs. frequency (1 W)

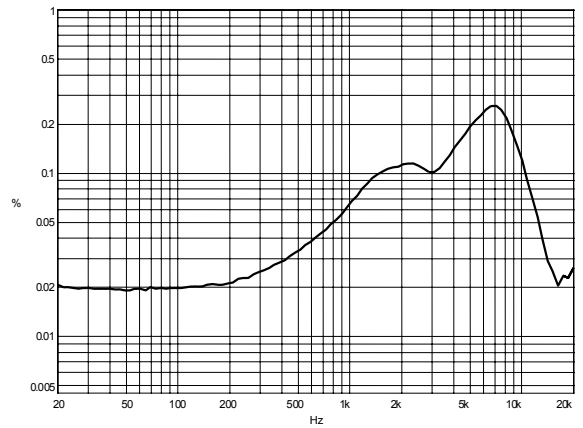

Figure 8. THD vs. frequency (100 mW)

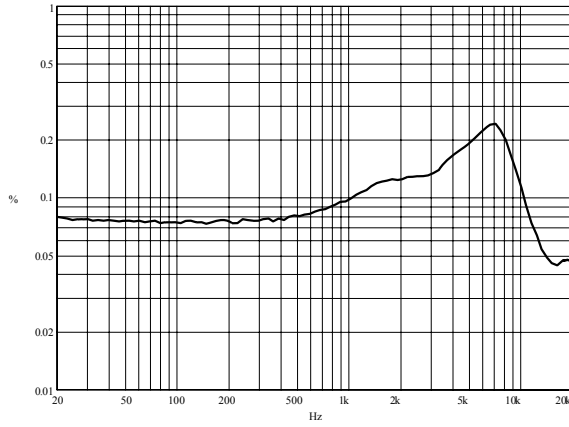

Figure 9. Frequency response

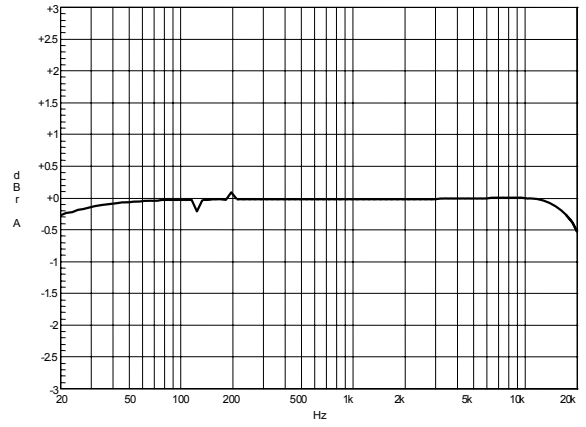

Figure 10. FFT performance (0 dBFS)

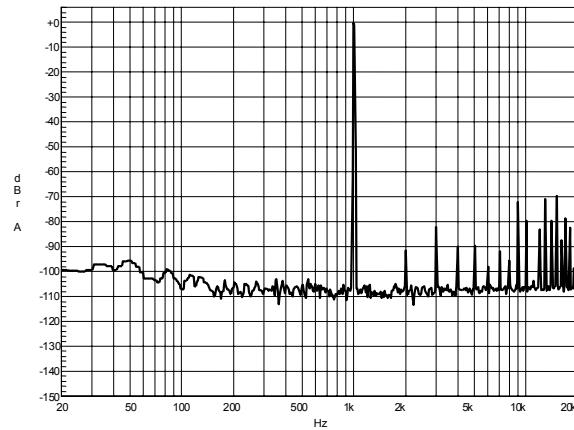
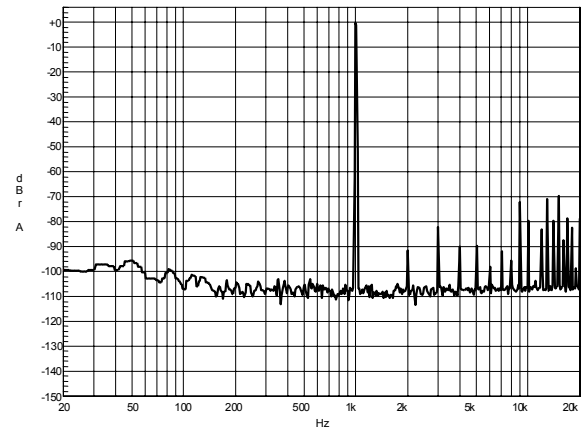

Figure 11. FFT performance (0 dBFS)



4.2.2 For $R_L = 8 \Omega$

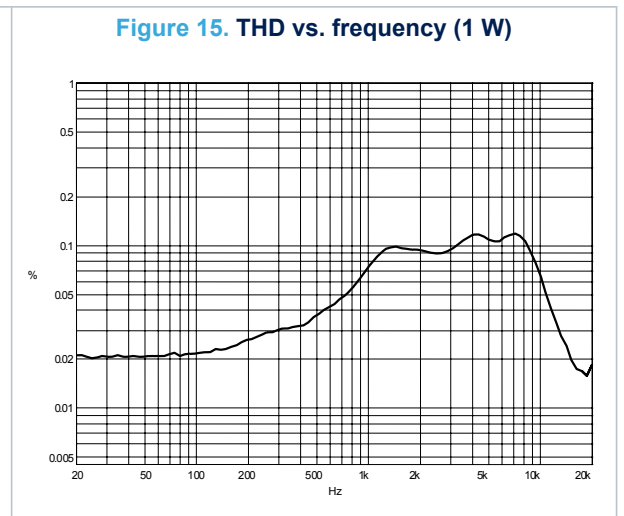
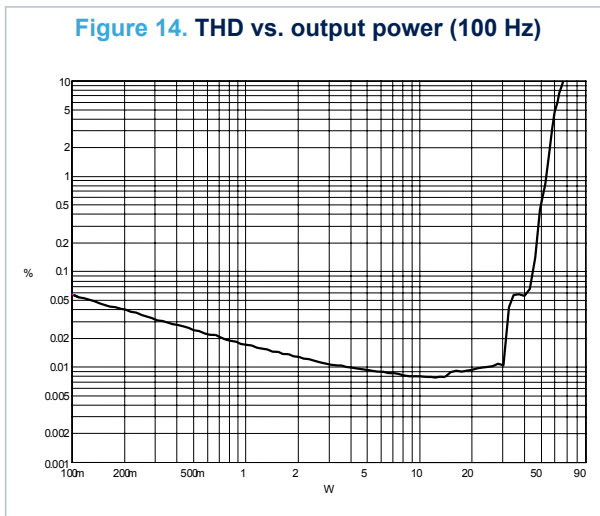
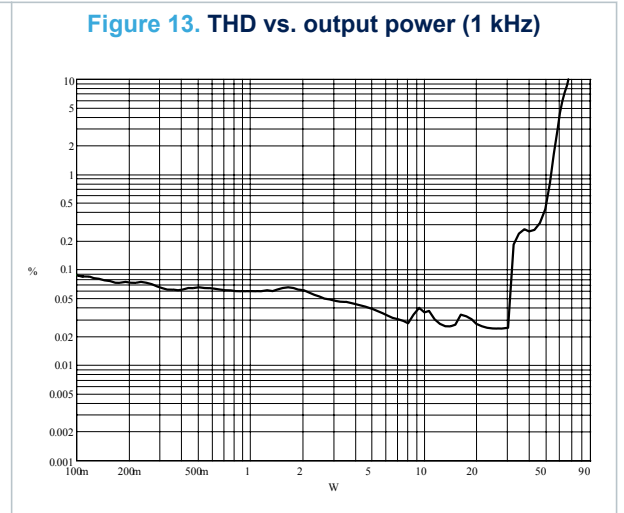
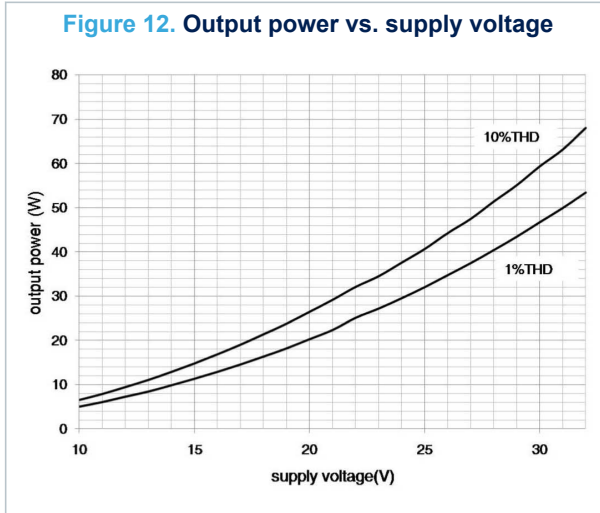

Figure 16. THD vs. frequency (100 mW)

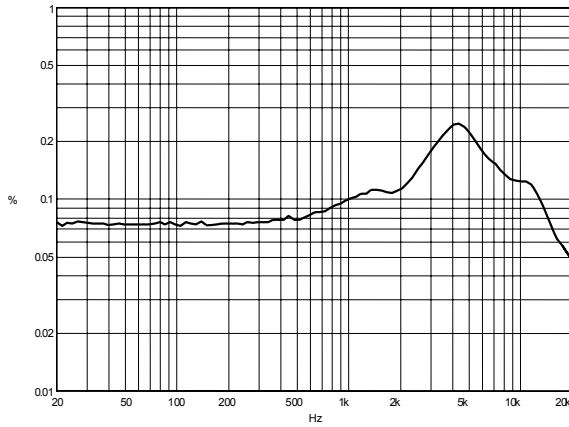

Figure 17. Frequency response

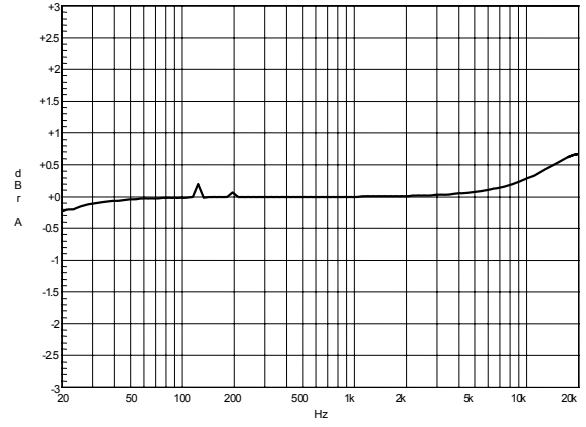

Figure 18. FFT performance (0 dB)

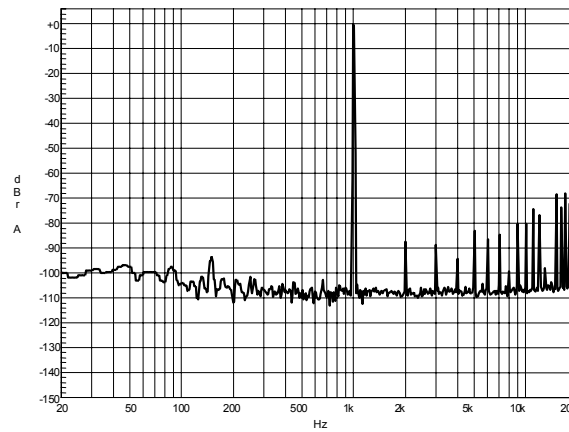
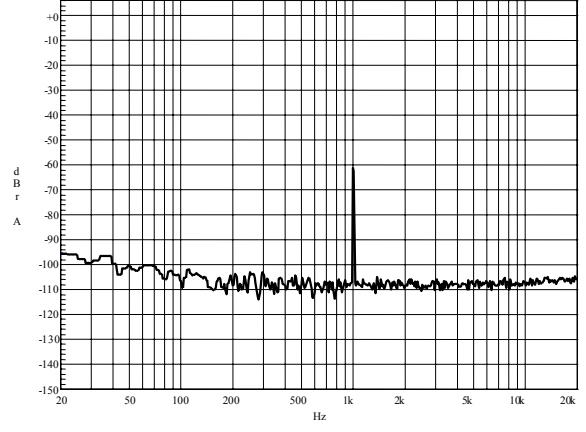

Figure 19. FFT performance (-60 dB)



5 Application information

5.1 Application circuit

Figure 20. Application circuit

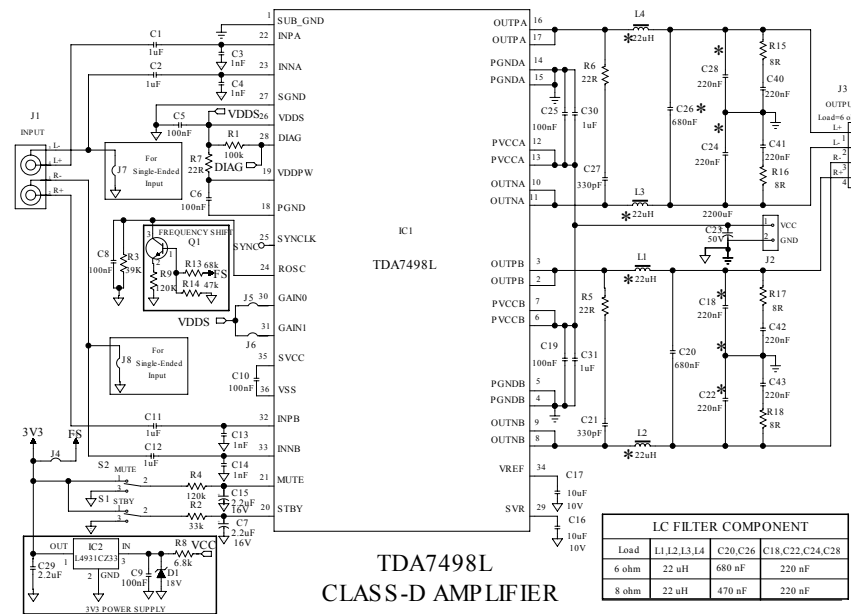

5.2 Mode selection

The three operating modes of the TDA7498L are set by the two inputs, STBY (pin 20) and MUTE (pin 21).

- Standby mode: all circuits are turned off, very low current consumption.
- Mute mode: inputs are connected to ground and the positive and negative PWM outputs are at 50% duty cycle.
- Play mode: the amplifiers are active.

The protection functions of the TDA7498L are enabled by pulling down the voltages of the STBY and MUTE inputs shown in Figure 21. Standby and mute circuits. The input current of the corresponding pins must be limited to 200 μ A.

Table 6. Mode settings

| Mode | STBY | MUTE |
|---------|------------------|----------------|
| Standby | L ⁽¹⁾ | X (don't care) |
| Mute | H ⁽¹⁾ | L |
| Play | H | H |

1. Drive levels defined in Table 5. Electrical characteristics

Figure 21. Standby and mute circuits

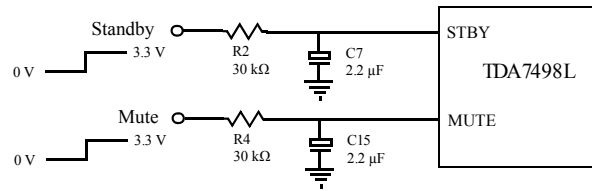
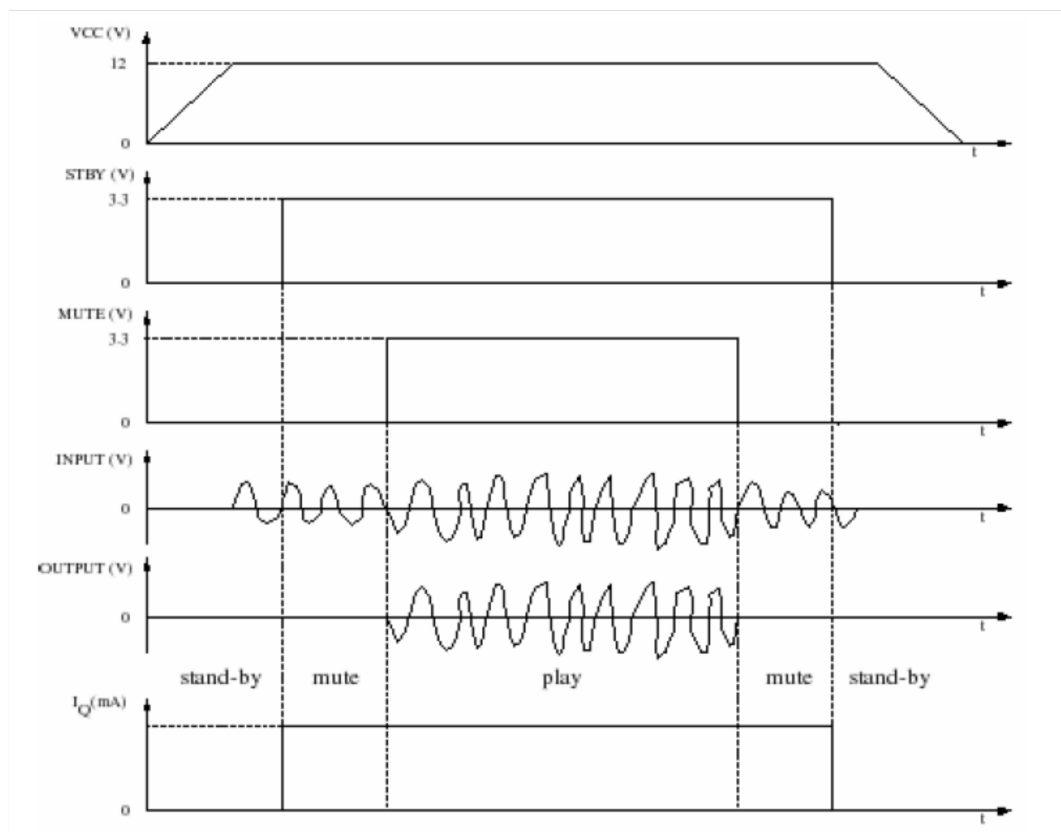

Figure 22. Turn on/off sequence for minimizing speaker “pop”



5.3 Gain settings

The gain of the TDA7498L is set by the two inputs, GAIN0 (pin 30) and GAIN1 (pin31). Internally, the gain is set by changing the feedback resistors of the amplifier.

Table 7. Gain settings

| GAIN0 | GAIN1 | Nominal gain, G_v (dB) |
|-------|-------|--------------------------|
| L | L | 25.6 |
| L | H | 31.6 |
| H | L | 35.6 |
| H | H | 37.6 |

5.4 Input resistance and capacitance

The input impedance is set by an internal resistor $R_i = 60 \text{ k}\Omega$ (typical). An input capacitor (C_i) is required to couple the AC input signal.

The equivalent circuit and frequency response of the input components are shown in Figure 23. Input circuit and frequency response. For $C_i = 470 \text{ nF}$ the high-pass filter cutoff frequency is below 20 Hz:

$$f_c = 1 / (2 * \pi * R_i * C_i)$$

Figure 23. Input circuit and frequency response

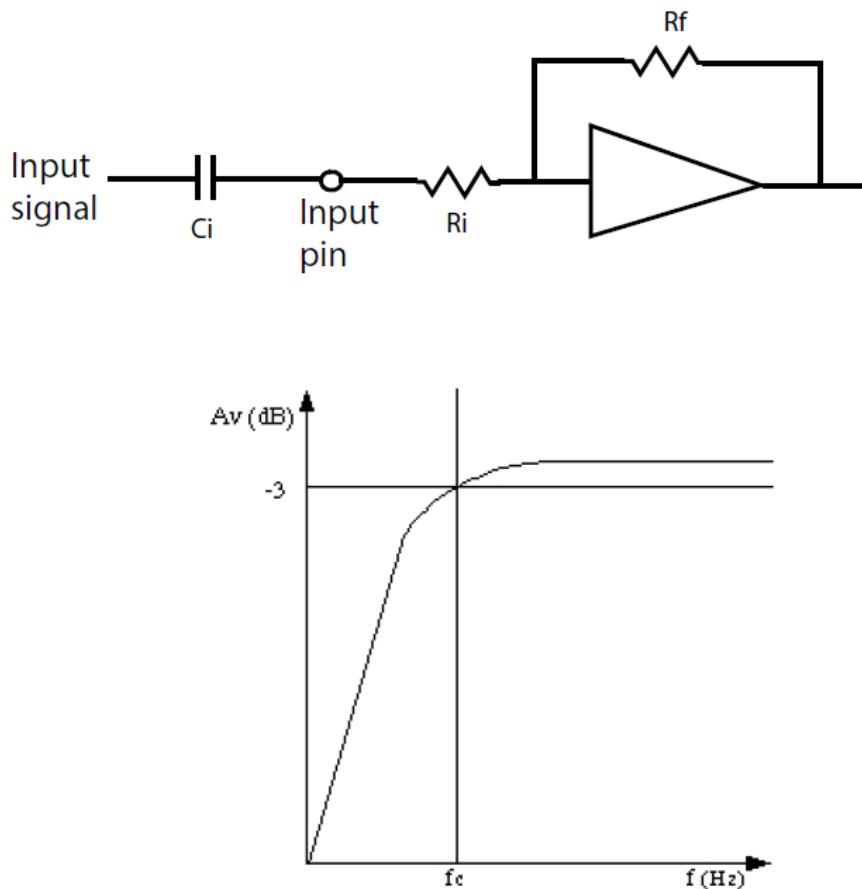

5.5 Internal and external clocks

The clock of the class-D amplifier can be generated internally or can be driven by an external source.

If two or more class-D amplifiers are used in the same system, it is recommended that all devices operate at the same clock frequency. This can be implemented by using one TDA7498L as master clock, while the other devices are in slave mode, that is, externally clocked. The clock interconnect is via pin SYNCLK of each device. As explained below, SYNCLK is an output in master mode and an input in slave mode.

5.5.1 Master mode (internal clock)

Using the internal oscillator, the output switching frequency, f_{SW} , is controlled by the resistor, R_{OSC} , connected to pin ROSC:

$$f_{SW} = 10^6 / [(R_{OSC} * 16 + 182) * 4] \text{ kHz}$$

where R_{OSC} is in $\text{k}\Omega$.

In master mode, pin SYNCLK is used as a clock output pin whose frequency is:

$$f_{SYNCLK} = 2 * f_{SW}$$

For master mode to operate correctly then resistor R_{OSC} must be less than 60 k Ω as given below in Table 8. How to set up SYNCLK.

5.5.2 Slave mode (external clock)

In order to accept an external clock input the pin ROSC must be left open, that is, floating. This forces pin SYNCLK to be internally configured as an input as given in Table 8. How to set up SYNCLK.

The output switching frequency of the slave devices is:

$$f_{SW} = f_{SYNCLK} / 2$$

Table 8. How to set up SYNCLK

| Mode | ROSC | SYNCLK |
|--------|--------------------------------|--------|
| Master | $R_{OSC} < 60 \text{ k}\Omega$ | Output |
| Slave | Floating (not connected) | Input |

Figure 24. Master and slave connection

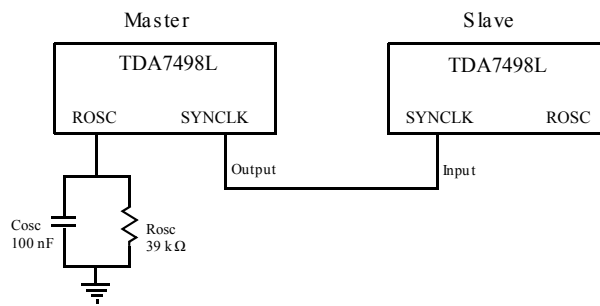

5.6 Output low-pass filter

To avoid EMI problems, it may be necessary to use a low-pass filter before the speaker. The cutoff frequency should be larger than 22 kHz and much lower than the output switching frequency. It is necessary to choose the L and C component values depending on the loudspeaker impedance. Some typical values, which give a cutoff frequency of 27 kHz, are shown in Figure 25. Typical LC filter for an 8 Ω speaker and Figure 26. Typical LC filter for a 6 Ω speaker below.

Figure 25. Typical LC filter for an 8 Ω speaker

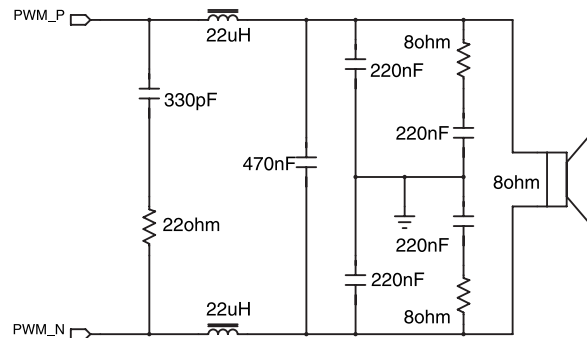
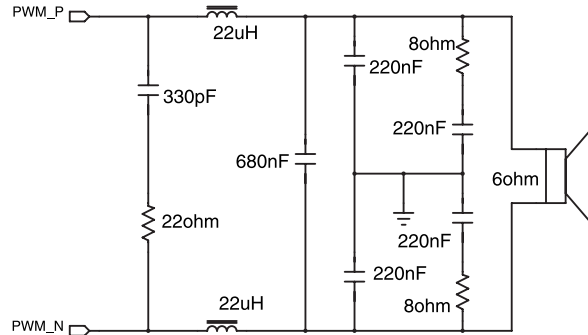

Figure 26. Typical LC filter for a 6 Ω speaker



5.7 Protection functions

The TDA7498L is fully protected against overvoltages, undervoltages, overcurrents and thermal overloads as explained here.

Overvoltage protection (OVP)

If the supply voltage exceeds the value for V_{OVP} given in [Table 5. Electrical characteristics](#), the overvoltage protection is activated which forces the outputs to the high-impedance state. When the supply voltage falls back to within the operating range, the device restarts.

Undervoltage protection (UVP)

If the supply voltage drops below the value for V_{UVP} given in [Table 5. Electrical characteristics](#), the undervoltage protection is activated which forces the outputs to the high-impedance state. When the supply voltage falls back to within the operating range, the device restarts.

Overcurrent protection (OCP)

If the output current exceeds the value for I_{OCP} given in [Table 5. Electrical characteristics](#), the overcurrent protection is activated which forces the outputs to the high-impedance state. Periodically, the device attempts to restart. If the overcurrent condition is still present then the OCP remains active. The restart time, T_{OC} , is determined by the RC components connected to pin STBY.

Thermal protection (OTP)

If the junction temperature, T_j , reaches 145 °C (nominally), the device goes to mute mode and the positive and negative PWM outputs are forced to 50% duty cycle. If the junction temperature reaches the value for T_j given in [Table 5. Electrical characteristics](#), the device shuts down and the output is forced to the high-impedance state. When the device cools sufficiently, the device restarts.

5.8 Diagnostic output

The output pin DIAG is an open drain transistor. When any protection is activated it switches to the high-impedance state. The pin can be connected to a power supply (< 36 V) by a pull-up resistor whose value is limited by the maximum sinking current (200 μA) of the pin.

Figure 27. Behavior of pin DIAG for various protection conditions

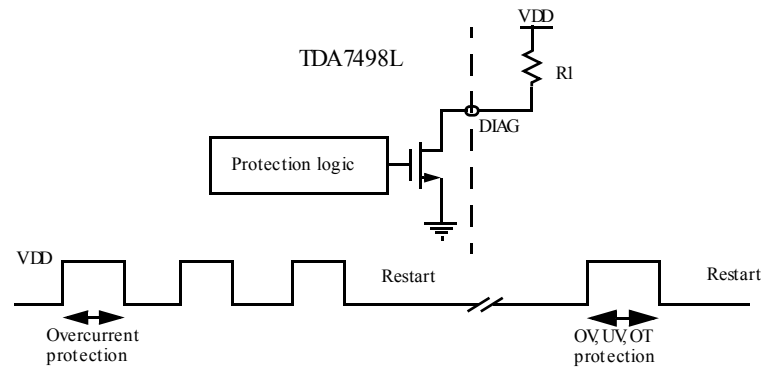

6 Package information

In order to meet environmental requirements, ST offers these devices in different grades of **ECOPACK** packages, depending on their level of environmental compliance. ECOPACK specifications, grade definitions and product status are available at: www.st.com. ECOPACK is an ST trademark.

6.1 PowerSSO-36 EPU package information

Figure 28. PowerSSO-36 EPU package outline

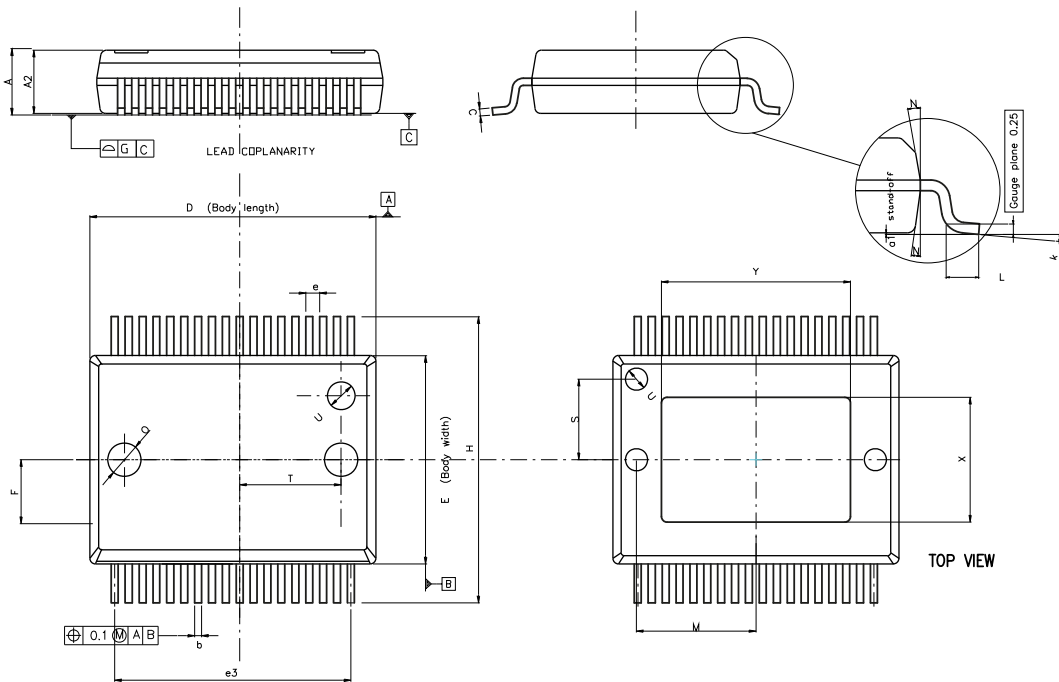

Table 9. PowerSSO-36 EPU package mechanical data

| Symbol | mm | | | inches | | |
|--------|-------|------|------------|--------|-------|------------|
| | Min. | Typ. | Max. | Min. | Typ. | Max. |
| A | 2.15 | - | 2.45 | 0.085 | - | 0.096 |
| A2 | 2.15 | - | 2.35 | 0.085 | - | 0.093 |
| a1 | 0 | - | 0.10 | 0 | - | 0.004 |
| b | 0.18 | - | 0.36 | 0.007 | - | 0.014 |
| c | 0.23 | - | 0.32 | 0.009 | - | 0.013 |
| D | 10.10 | - | 10.50 | 0.398 | - | 0.413 |
| E | 7.40 | - | 7.60 | 0.291 | - | 0.299 |
| e | - | 0.5 | - | - | 0.020 | - |
| e3 | - | 8.5 | - | - | 0.335 | - |
| F | - | 2.3 | - | - | 0.091 | - |
| G | - | - | 0.10 | - | - | 0.004 |
| H | 10.10 | - | 10.50 | 0.398 | - | 0.413 |
| h | - | - | 0.40 | - | - | 0.016 |
| k | 0 | - | 8 degrees | 0 | - | 8 degrees |
| L | 0.55 | - | 0.85 | 0.022 | - | 0.033 |
| M | - | 4.30 | - | - | 0.169 | - |
| N | - | - | 10 degrees | - | - | 10 degrees |
| O | - | 1.20 | - | - | 0.047 | - |
| Q | - | 0.80 | - | - | 0.031 | - |
| S | - | 2.90 | - | - | 0.114 | - |
| T | - | 3.65 | - | - | 0.144 | - |
| U | - | 1.00 | - | - | 0.039 | - |
| X | 4.10 | - | 4.70 | 0.161 | - | 0.185 |
| Y | 6.50 | - | 7.10 | 0.193 | - | 0.280 |

Revision history

Table 10. Document revision history

| Date | Revision | Changes |
|-------------|----------|---|
| 04-Dec-2009 | 1 | Initial release. |
| 02-Jul-2010 | 2 | Removed datasheet preliminary status, updated Section Features list and Table 1. Device summary Updated minimum supply voltage and temperature range in Table 5. Recommended operating conditions Updated typical power output for 8 Ω to 32 V in Table 6. Electrical specifications |
| 12-Sep-2011 | 3 | Updated OUTNA in Table 2. Pin description list; minor textual updates |
| 09-Sep-2015 | 4 | Updated VCC_MAX in Table 3. Absolute maximum ratings and dimension L in Table 10. PowerSSO-36 EPU package mechanical data |
| 24-Jan-2019 | 5 | Updated product summary table in cover page |
| 26-Jul-2020 | 6 | Updated Figure 28 and Y min. value in Table 9 |

Contents

| | | |
|----------|---|-----------|
| 1 | Device block diagram | 2 |
| 2 | Pin description | 3 |
| 2.1 | Pinout | 3 |
| 2.2 | Pin list | 4 |
| 3 | Electrical specifications | 5 |
| 3.1 | Absolute maximum ratings | 5 |
| 3.2 | Thermal data | 5 |
| 3.3 | Recommended operating conditions | 5 |
| 3.4 | Electrical specifications | 6 |
| 4 | Characterization curves | 8 |
| 4.1 | PCB layout | 8 |
| 4.2 | Characterization curves | 8 |
| 4.2.1 | For $R_L = 6 \Omega$ | 9 |
| 4.2.2 | For $R_L = 8 \Omega$ | 11 |
| 5 | Application information | 13 |
| 5.1 | Application circuit | 13 |
| 5.2 | Mode selection | 13 |
| 5.3 | Gain setting | 14 |
| 5.4 | Input resistance and capacitance | 15 |
| 5.5 | Internal and external clocks | 15 |
| 5.5.1 | Master mode (internal clock) | 15 |
| 5.5.2 | Slave mode (external clock) | 16 |
| 5.6 | Output low-pass filter | 16 |
| 5.7 | Protection functions | 17 |
| 5.8 | Diagnostic output | 17 |
| 6 | Package information | 19 |
| 6.1 | PowerSSO-36 EPU package information | 19 |
| | Revision history | 21 |

IMPORTANT NOTICE – PLEASE READ CAREFULLY

STMicroelectronics NV and its subsidiaries (“ST”) reserve the right to make changes, corrections, enhancements, modifications, and improvements to ST products and/or to this document at any time without notice. Purchasers should obtain the latest relevant information on ST products before placing orders. ST products are sold pursuant to ST’s terms and conditions of sale in place at the time of order acknowledgement.

Purchasers are solely responsible for the choice, selection, and use of ST products and ST assumes no liability for application assistance or the design of Purchasers’ products.

No license, express or implied, to any intellectual property right is granted by ST herein.

Resale of ST products with provisions different from the information set forth herein shall void any warranty granted by ST for such product.

ST and the ST logo are trademarks of ST. For additional information about ST trademarks, please refer to www.st.com/trademarks. All other product or service names are the property of their respective owners.

Information in this document supersedes and replaces information previously supplied in any prior versions of this document.

© 2020 STMicroelectronics – All rights reserved

Компания «Океан Электроники» предлагает заключение долгосрочных отношений при поставках импортных электронных компонентов на взаимовыгодных условиях!

Наши преимущества:

- Поставка оригинальных импортных электронных компонентов напрямую с производств Америки, Европы и Азии, а так же с крупнейших складов мира;
- Широкая линейка поставок активных и пассивных импортных электронных компонентов (более 30 млн. наименований);
- Поставка сложных, дефицитных, либо снятых с производства позиций;
- Оперативные сроки поставки под заказ (от 5 рабочих дней);
- Экспресс доставка в любую точку России;
- Помощь Конструкторского Отдела и консультации квалифицированных инженеров;
- Техническая поддержка проекта, помощь в подборе аналогов, поставка прототипов;
- Поставка электронных компонентов под контролем ВП;
- Система менеджмента качества сертифицирована по Международному стандарту ISO 9001;
- При необходимости вся продукция военного и аэрокосмического назначения проходит испытания и сертификацию в лаборатории (по согласованию с заказчиком);
- Поставка специализированных компонентов военного и аэрокосмического уровня качества (Xilinx, Altera, Analog Devices, Intersil, Interpoint, Microsemi, Actel, Aeroflex, Peregrine, VPT, Syfer, Eurofarad, Texas Instruments, MS Kennedy, Miteq, Cobham, E2V, MA-COM, Hittite, Mini-Circuits, General Dynamics и др.);

Компания «Океан Электроники» является официальным дистрибьютором и эксклюзивным представителем в России одного из крупнейших производителей разъемов военного и аэрокосмического назначения «JONHON», а так же официальным дистрибьютором и эксклюзивным представителем в России производителя высокотехнологичных и надежных решений для передачи СВЧ сигналов «FORSTAR».



JONHON

«JONHON» (основан в 1970 г.)

Разъемы специального, военного и аэрокосмического назначения:

(Применяются в военной, авиационной, аэрокосмической, морской, железнодорожной, горно- и нефтедобывающей отраслях промышленности)

«FORSTAR» (основан в 1998 г.)

ВЧ соединители, коаксиальные кабели, кабельные сборки и микроволновые компоненты:

(Применяются в телекоммуникациях гражданского и специального назначения, в средствах связи, РЛС, а так же военной, авиационной и аэрокосмической отраслях промышленности).



Телефон: 8 (812) 309-75-97 (многоканальный)

Факс: 8 (812) 320-03-32

Электронная почта: ocean@oceanchips.ru

Web: <http://oceanchips.ru/>

Адрес: 198099, г. Санкт-Петербург, ул. Калинина, д. 2, корп. 4, лит. А