

# QUICK START GUIDE FOR DEMONSTRATION CIRCUIT 992

## MONOLITHIC SYNCHRONOUS BUCK REGULATOR

### LTC3549EDCB

## DESCRIPTION

Demonstration circuit 992 is a Step-Down Converter, using the LTC3549 monolithic synchronous buck regulator. The DC992A has an input voltage range of 1.6V to 5.5V, and is capable of delivering up to 250 mA of output current at a minimum input voltage of 1.8V. The output voltage of the DC992A can be set as low as 0.611V, the reference voltage of the LTC3549. At low load currents, the DC992A can operate in either noise sensitive applications, due to the capability of the LTC3549 to operate in pulse-skipping mode, or in high efficiency applications, because the LTC3549 can also operate in Burst-Mode. Of course, in continuous mode, or large load current applications, the DC992A is a

high efficiency circuit - over 90%. The DC992A consumes only 50 uA during sleep mode operation, and during shutdown, it consumes at less than 1 uA typically. Because of the high switching frequency of the LTC3549 - 2.25 MHz - the DC992A uses low profile surface mount components. These features, plus the LTC3549 coming in a small 6-Lead DFN package, make the DC992A an ideal circuit for use in battery-powered, hand-held applications.

**Design files for this circuit board are available. Call the LTC factory.**

LTC is a trademark of Linear Technology Corporation

**Table 1.**

Performance Summary ( $T_A = 25^\circ\text{C}$ )

PARAMETER	CONDITIONS	VALUE
Minimum Input Voltage		1.6V
Maximum Input Voltage		5.5V
Output Voltage $V_{OUT}$ Regulation	$V_{IN} = 1.6\text{V to } 5.5\text{V}$ , $I_{OUT} = 0\text{A to } 250\text{ mA}$	1.2V $\pm 4\%$ (1.152V to 1.248V) 1.5V $\pm 4\%$ (1.44V to 1.56V) 1.8V $\pm 4\%$ (1.728V to 1.872V)
Typical Output Ripple $V_{OUT}$	$V_{IN} = 3.6\text{V}$ , $I_{OUT} = 250\text{ mA}$ (20 MHz BW)	<20mV <sub>p-p</sub>
Operation Modes	Burst Mode - $V_{IN} = 3.6\text{V}$ , $V_{OUT} = 1.8\text{V}$	$\sim 40\text{ mA} \pm 8\text{ mA}$
	Pulse-Skip - $V_{IN} = 3.6\text{V}$ , $V_{OUT} = 1.8\text{V}$	$\sim 40\text{ mA} \pm 8\text{ mA}$
Nominal Switching Frequency		2.25 MHz

## QUICK START PROCEDURE

Demonstration circuit 992 is created to evaluate the performance of the LTC3549. For proper measurement equipment configuration, set up the circuit according to the diagram in **Figure 1**. Before proceeding to test, insert jumper JP1 shunt into the off position, connecting the RUN pin to ground (GND), which shuts down the circuit. Also insert shunts into the Pulse-Skip position of jumper JP2, and into the 1.2V output voltage position.

**NOTE:** When measuring the input or output voltage ripple, care must be taken to avoid a long ground lead on the oscilloscope probe. Measure the input or output voltage ripple by touching the probe tip directly across the Vin or Vout and GND terminals. See **Figure 2** for proper scope probe technique.

1. Apply 3.6V at Vin and set the load to 50 mA. Measure Vout; it should read 0V. If desired, one can measure the shutdown supply current at this point. The supply current will be approximately 1 uA in shutdown.
2. Turn on the circuit by inserting the shunt in jumper JP1 into the ON position. The output voltage should be regulating. Measure Vout - it should measure 1.2V +/- 2% (1.176V to 1.224V).
3. Vary the input voltage from 1.6V to 5.5V and adjust the load current from 0 to 250 mA. Vout should read between 1.2V +/- 4% (1.152V to 1.248V). Measure the output ripple voltage at any output current level above 50 mA; it will measure less than 20 mVAC. The Burst-Mode™ and Pulse-Skip capability of the LTC3549 can also be observed now by setting the JP2 jumper shunt into either the Pulse-Skip position or the Burst-Mode™ position, and decreasing the load current below ~40 mA.
4. Observe the voltage waveform at the switch node. Verify the switching frequency is between 1.8 MHz and 2.7 MHz (T = 0.556 us and 0.37 us), and that the switch node waveform is rectangular in shape.

Insert jumper JP1 shunt into the OFF position and move the 1.2V Vout shunt into any of the remaining output voltage options: 1.5V or 1.8V. Just as in the 1.2Vout test, the output voltage should read Vout +/- 2% tolerance under static line and load conditions, and another +/- 2% tolerance under dynamic line and load conditions (+/- 4% total). When finished, turn off the circuit by inserting the jumper JP1 shunt into the OFF position.

# QUICK START GUIDE FOR DEMONSTRATION CIRCUIT 992

## MONOLITHIC SYNCHRONOUS BUCK REGULATOR

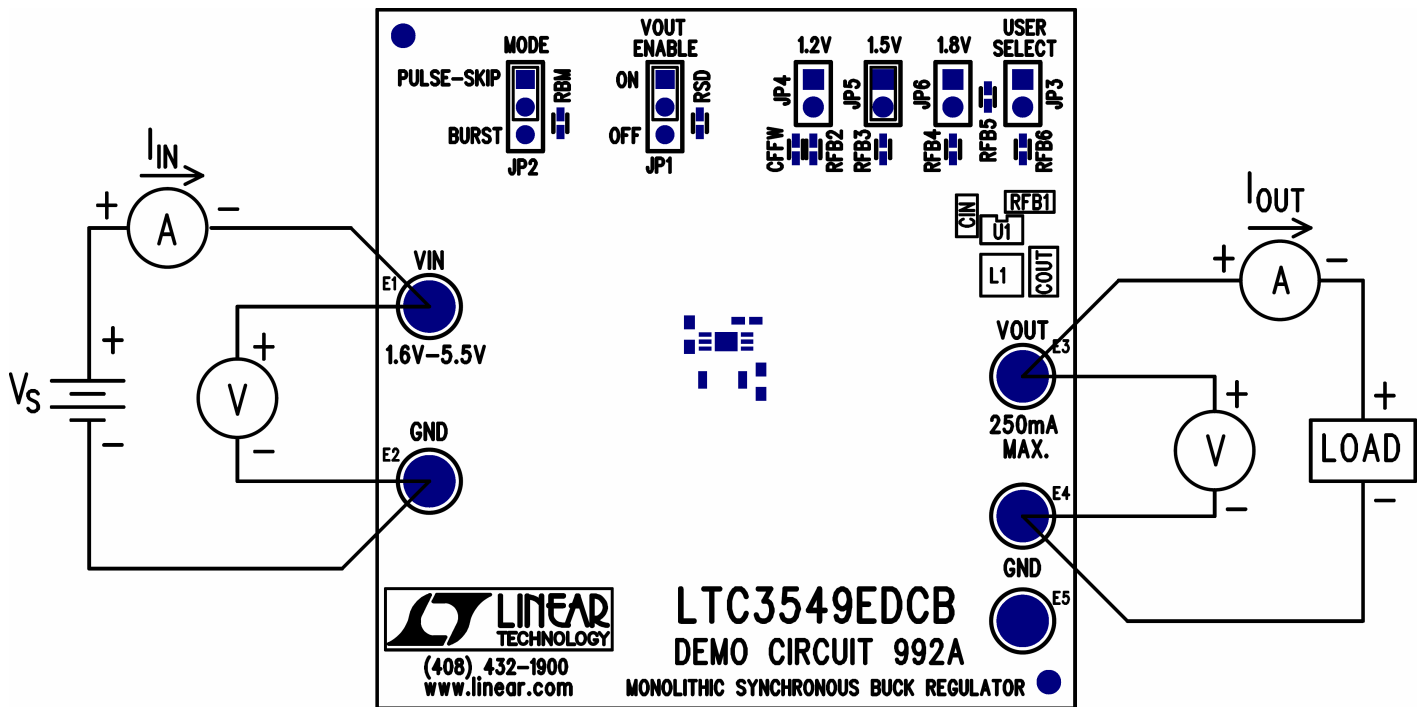

Figure 1. Proper Measurement Equipment Setup

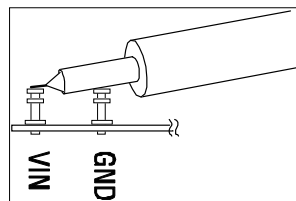
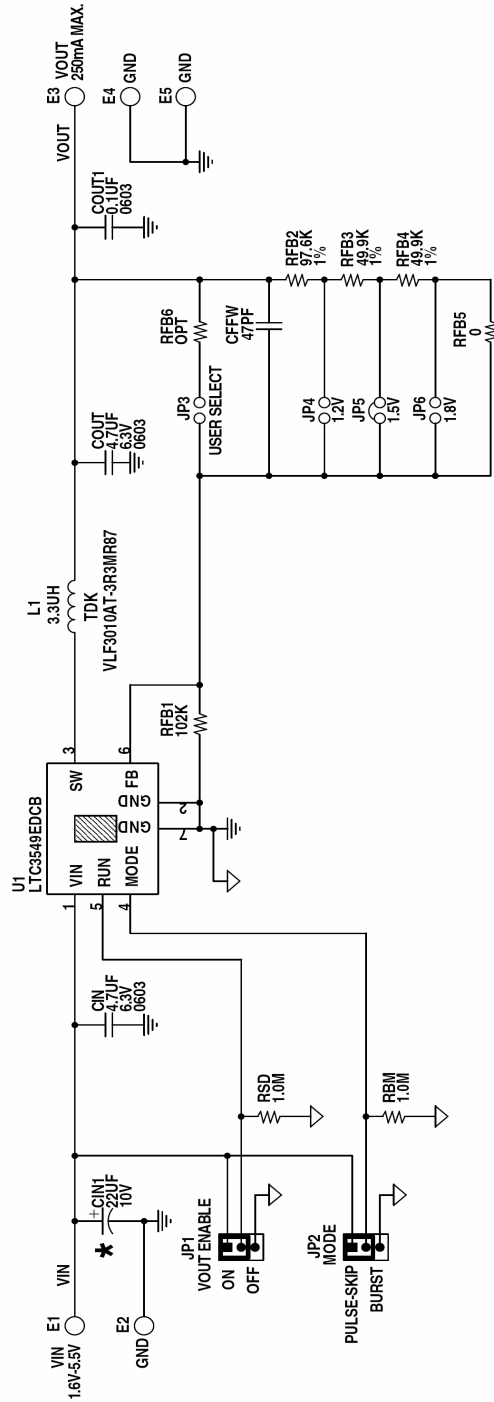

Figure 2. Measuring Input or Output Ripple

# QUICK START GUIDE FOR DEMONSTRATION CIRCUIT 992

## MONOLITHIC SYNCHRONOUS BUCK REGULATOR



### NOTES: UNLESS OTHERWISE SPECIFIED

- ALL RESISTORS ARE IN OHMS, 0402.  
ALL CAPACITORS ARE 0402.
  - INSTALL SHUNT ON JP1-JP2 & JP5 PIN 1 AND 2.
- ★ CIN1 IS AN OPTIONAL CAPACITOR. IT IS INSERTED ON THE DC992A TO DAMPEN THE (POSSIBLE) RINGING VOLTAGE DUE TO THE LONG INPUT LEADS. ON A NORMAL, TYPICAL PCB, WITH SHORT TRACES, THE CAPACITOR IS NOT NEEDED.

<b>CUSTOMER NOTICE</b>		<b>CONTRACT NO.</b>	
LINEAR TECHNOLOGY HAS MADE A BEST EFFORT TO DESIGN A CIRCUIT THAT MEETS CUSTOMER-SUPPLIED SPECIFICATIONS; HOWEVER, IT REMAINS THE CUSTOMER'S RESPONSIBILITY TO VERIFY PROPER AND RELIABLE OPERATION IN THE ACTUAL APPLICATION. COMPONENT SUBSTITUTION AND PRINTED CIRCUIT BOARD LAYOUT MAY SIGNIFICANTLY AFFECT CIRCUIT PERFORMANCE OR RELIABILITY. CONTACT LINEAR TECHNOLOGY APPLICATIONS ENGINEERING FOR ASSISTANCE.		APPROVALS	
THIS CIRCUIT IS PROPRIETARY TO LINEAR TECHNOLOGY AND SUPPLIED FOR USE WITH LINEAR TECHNOLOGY PARTS.		DRAWN: KIM T.	
		CHECKED:	
		APPROVED:	
		ENGINEER: TOM G.	
		DESIGNER:	
		TITLE: SCHEMATIC	
		MONOLITHIC SYNCHRONOUS BUCK REGULATOR	
		SIZE: A	
		DWG NO. DC992A-1 * LTC3549EDCB	
		REV: A-1	
		DATE: Wednesday, August 23, 2006	
		SHEET 1 OF 1	

1630 McCarthy Blvd.  
Milpitas, CA 95035  
Phone: (408)432-1900  
Fax: (408)434-0507  
LTC Confidential-For Customer Use Only



Компания «Океан Электроники» предлагает заключение долгосрочных отношений при поставках импортных электронных компонентов на взаимовыгодных условиях!

Наши преимущества:

- Поставка оригинальных импортных электронных компонентов напрямую с производств Америки, Европы и Азии, а так же с крупнейших складов мира;
- Широкая линейка поставок активных и пассивных импортных электронных компонентов (более 30 млн. наименований);
- Поставка сложных, дефицитных, либо снятых с производства позиций;
- Оперативные сроки поставки под заказ (от 5 рабочих дней);
- Экспресс доставка в любую точку России;
- Помощь Конструкторского Отдела и консультации квалифицированных инженеров;
- Техническая поддержка проекта, помощь в подборе аналогов, поставка прототипов;
- Поставка электронных компонентов под контролем ВП;
- Система менеджмента качества сертифицирована по Международному стандарту ISO 9001;
- При необходимости вся продукция военного и аэрокосмического назначения проходит испытания и сертификацию в лаборатории (по согласованию с заказчиком);
- Поставка специализированных компонентов военного и аэрокосмического уровня качества (Xilinx, Altera, Analog Devices, Intersil, Interpoint, Microsemi, Actel, Aeroflex, Peregrine, VPT, Syfer, Eurofarad, Texas Instruments, MS Kennedy, Miteq, Cobham, E2V, MA-COM, Hittite, Mini-Circuits, General Dynamics и др.);

Компания «Океан Электроники» является официальным дистрибьютором и эксклюзивным представителем в России одного из крупнейших производителей разъемов военного и аэрокосмического назначения «JONHON», а так же официальным дистрибьютором и эксклюзивным представителем в России производителя высокотехнологичных и надежных решений для передачи СВЧ сигналов «FORSTAR».



## JONHON

«JONHON» (основан в 1970 г.)

Разъемы специального, военного и аэрокосмического назначения:

(Применяются в военной, авиационной, аэрокосмической, морской, железнодорожной, горно- и нефтедобывающей отраслях промышленности)

«FORSTAR» (основан в 1998 г.)

ВЧ соединители, коаксиальные кабели,  
кабельные сборки и микроволновые компоненты:

(Применяются в телекоммуникациях гражданского и специального назначения, в средствах связи, РЛС, а так же военной, авиационной и аэрокосмической отраслях промышленности).



Телефон: 8 (812) 309-75-97 (многоканальный)

Факс: 8 (812) 320-03-32

Электронная почта: [ocean@oceanchips.ru](mailto:ocean@oceanchips.ru)

Web: <http://oceanchips.ru/>

Адрес: 198099, г. Санкт-Петербург, ул. Калинина, д. 2, корп. 4, лит. А