

NOTES:

- 1. PART NUMBER VARIABLES: (SEE SHEET 2 FOR ADDITIONAL INFORMATION)  
NOT ALL POSSIBLE CONFIGURATIONS SHOWN ON THIS DRAWING ARE AVAILABLE AS STANDARD PRODUCTS. PLEASE CHECK WITH TE CONNECTIVITY TO CONFIRM AVAILABILITY.
- MTC100-BXX-PXX-XXX MODIFICATION NUMBER. REFER TO APPLICABLE MOD DESCRIPTION SHEET. "BLANK WHEN NOT APPLICABLE"
- 1=LONG TAIL  
2=SHORT TAIL  
3=90° IN "B" DIRECTION
- 2=NICKEL PLATE  
3=CADMIUM OVER NICKEL PLATE
- 1=1 INCH  
2=2 INCH
- F=FLANGED WITH STANDARD PANEL GASKET  
S=FLANGED/SHIELDED WITH EME PANEL GASKET  
J=FLANGELESS  
Y=SPECIALS: REFER TO INDIVIDUAL SPECIFICATION CONTROL DRAWINGS FOR DESCRIPTIONS
- 2. A BOX MOUNT RECEPTACLE MATES WITH A MTC PLUG CONTAINING SOCKET INSERTS. REFER TO APPLICABLE TE CONNECTIVITY SPECIFICATION CONTROL DRAWING FOR DETAILS.
- 3. FOR KEYING INFORMATION, SEE TE CONNECTIVITY DRAWING D-659-0080.
- 4. THESE ITEMS ARE SUPPLIED UNASSEMBLED.
- 5. DIMENSION SHOWN IS WITH MATED PLUG CONNECTOR: a. WITH CABLE CLAMP  
b. WITHOUT CABLE CLAMP AND WITHOUT EARS
- 6. THIS BOX MOUNT RECEPTACLE IS REAR PANEL MOUNTED BY REMOVING AS MANY PANEL WASHERS AS REQUIRED TO ACCOMMODATE THE THICKNESS OF THE PANEL BEING USED. SEE SHEET 2, TABLE 2, AND SHEET 3, FIGURE 2.
- 7. FOR FRONT PANEL MOUNTING OF A FLANGELESS CONNECTOR, USE HARDWARE KIT CHA-0038-00 AND REFER TO THAT SPECIFICATION CONTROL DRAWING FOR APPLICATION DETAILS.
- 8. WIRE WRAPPABLE POST DESIGNED BY STANDARD WIRE WRAP SPECIFICATION.
- 9. WHEN MOUNTING FLANGELESS CONNECTORS ADJACENT TO ONE ANOTHER AND USING THE .400 MINIMUM CENTERLINE LOCATION, THERE WILL BE NO WEB BETWEEN PANEL CUT-OUTS. SEE SHEET 3, FIGURE 2 FOR DETAILS.
- 10. KIT NUMBER CHA-0046 IS AVAILABLE FOR MOUNTING A CONNECTOR TO A PRINTED CIRCUIT BOARD. SEE SHEET 3, FIGURE 3 FOR HOLE PATTERN RECOMMENDATION.
- 11. SEE SHEET 3, TABLE 3, FOR WEIGHTS. WEIGHTS SHOWN ARE WITHOUT DUST CAP AND WITHOUT POST PROTECTOR.
- 12. DUST CAP SUPPLIED WITH ASSEMBLY.
- 13. TORQUE MOUNTING HARDWARE TO: 14-16 IN-LBS.
- 14. THE FLANGE THICKNESS IS DIFFERENT ACCORDING TO SHELL STYLE AND SIZE.  
THE THICKNESS: 0.170 [4.32] FOR P/N MTC100-BF2-PXX AND MTC100-BS2-PXX.  
THE THICKNESS: 0.160 [4.06] FOR P/N MTC100-BX1-PXX AND MTC100-BJ2-PXX.

REVISIONS			
LTR	DESCRIPTION	DATE	APPROVED
J1	REVISED PER ECO-11-005139	29MAR11	RK/HMR

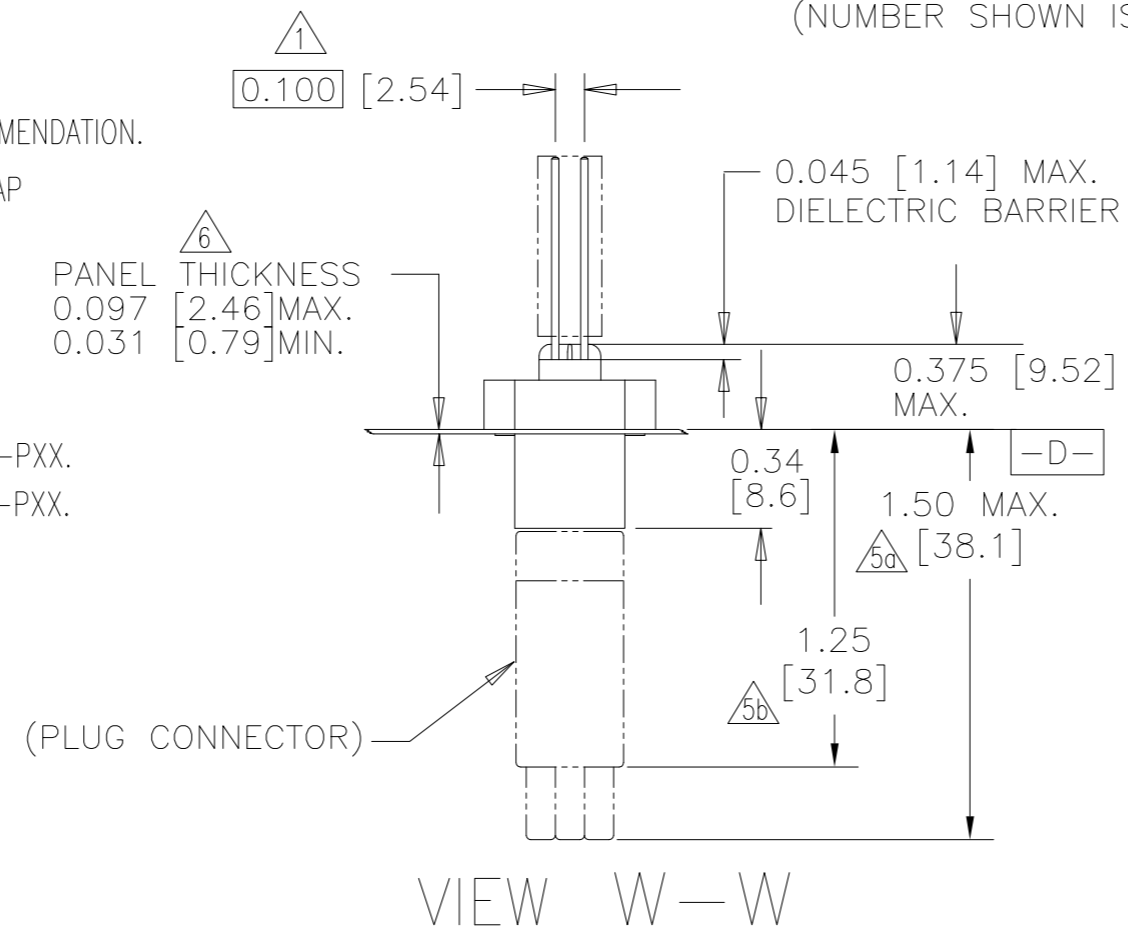
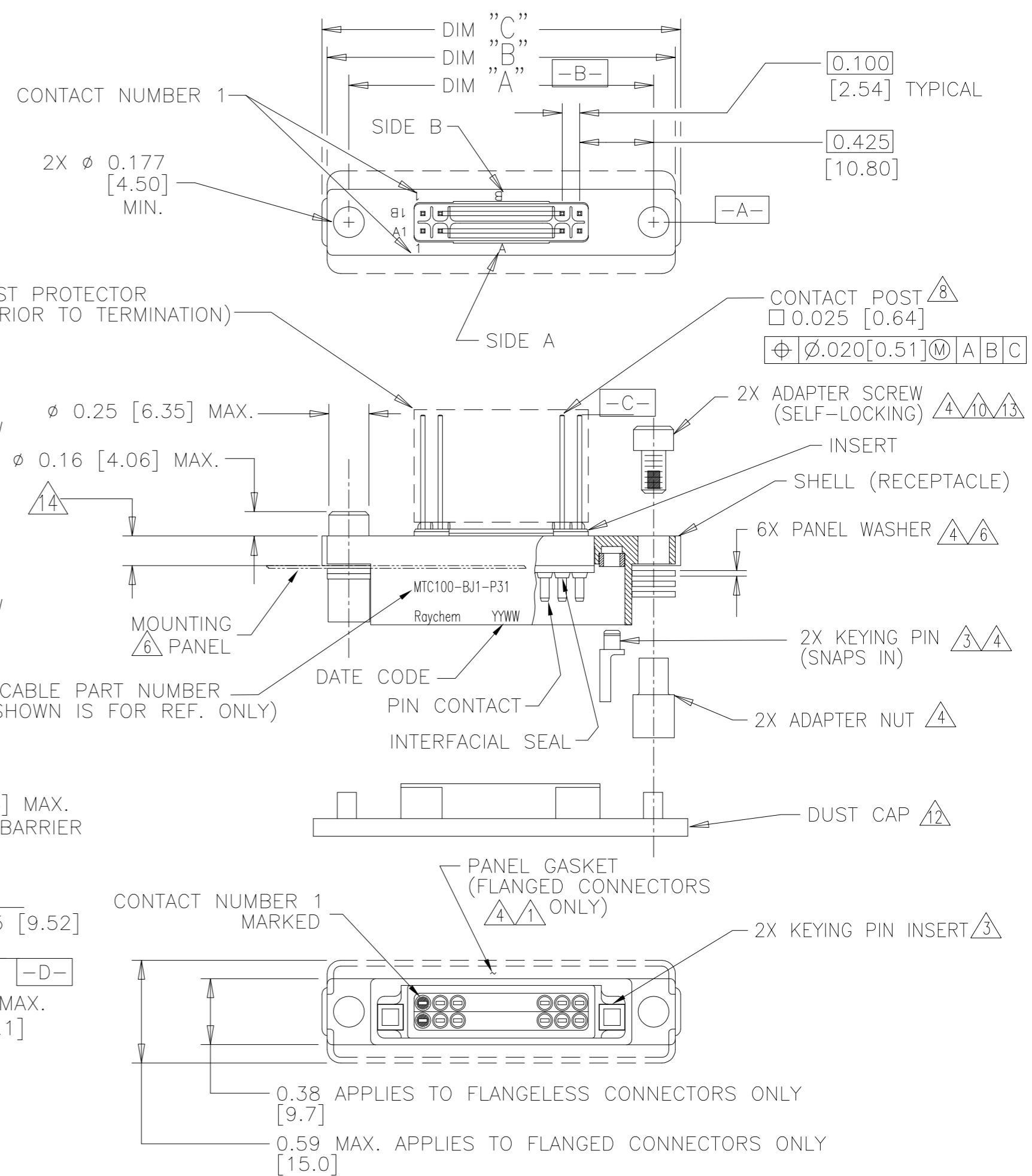

CUSTOMER DRAWING

IF THIS DOCUMENT IS PRINTED IT BECOMES UNCONTROLLED. CHECK FOR THE LATEST REVISION.

UNLESS OTHERWISE SPECIFIED DIMENSIONS ARE IN INCHES. METRIC DIMENSIONS ARE IN BRACKETS.  DECIMALS .XXX ± .005 {0.13mm} .XX ± .01 {0.25mm} ANGLES .X ± WEIGHT	RE-DRAWN	J.VALENTA	04/20/99	TE Connectivity	Raychem Interconnect 300 Constitution Drive Menlo Park, CA 94025 U.S.A
	CHECKED				
	APPROVED	M.HIGGY	04/23/99	TITLE	CONNECTOR, RECEPTACLE, BOX MOUNT, .025 SQ., TERMINATION POST, MTC100 SERIES
	CAD NAME	MTC100-BXX-PXX-XXX			SIZE
THIRD ANGLE PROJECTION				CAGE CODE:	06090
				DWG. NO.	MTC100-BXX-PXX-XXX
				REV	J1
				SCALE: NONE	SHEET 1 OF 3

SHEET 1  
DWG NO. MTC100-BXX-PXX-XXX

4

3

2

1

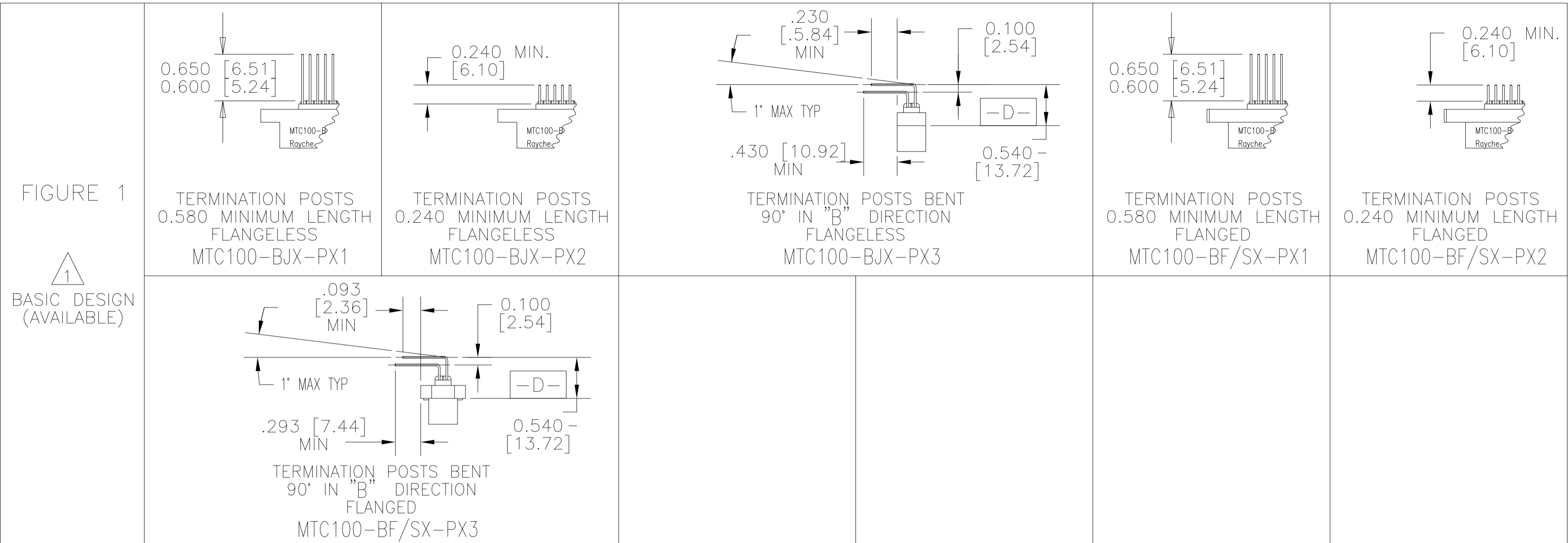

TABLE 1

CONNECTOR SIZE	"A"	"B"	"C"	"X"	"Y"	"Z" (MIN)
1 INCH	FLANGELESS 1.750 [44.45]	2.00 [50.8]	X	1.750 [44.45]	1.520 [38.61]	0.400 [10.16]
	FLANGED 1.750 [44.45]	X	2.06 [52.3]	1.750 [44.45]	1.520 [38.61]	0.600 [15.24]
2 INCH	FLANGELESS 2.750 [69.85]	3.00 [76.2]	X	2.750 [69.85]	2.520 [64.00]	0.400 [10.16]
	FLANGED 2.750 [69.85]	X	3.06 [77.7]	2.750 [69.85]	2.520 [64.00]	0.600 [15.24]

TABLE 2

PANEL THICKNESS	NUMBER OF PANEL WASHERS FOR EACH FASTENER
0.031/0.036 [0.8]/[0.9]	2
0.062/0.067 [1.5]/[1.7]	1
0.93/0.097 [2.3]/[2.4]	0

IF THIS DOCUMENT IS PRINTED IT BECOMES UNCONTROLLED.  
 CHECK FOR THE LATEST REVISION.

CUSTOMER DRAWING

SIZE C	CAGE CODE: 06090	DWG. NO. MTC100-BXX-PXX-XXX	REV. J1
CAD NAME: MTC100-BXX-PXX-XXX		SCALE: NONE	SHEET 2 OF 3

4

3

2

1

SHEET 2  
 DWG. NO. MTC100-BXX-PXX-XXX

SPECIFICATIONS:

MATERIALS:

- A. SHELL ALUMINUM ALLOY PER ASTM B85 / B85M
- B. ADAPTER SCREW STAINLESS STEEL PER SAE-AMS-QQ-S-763, 300 SERIES
- C. ADAPTER NUT STAINLESS STEEL PER SAE-AMS-QQ-S-763, 300 SERIES
- D. STANDARD PANEL GASKET SILICONE ELASTOMER PER MIL-STD-25988  
EMI PANEL GASKET CONDUCTIVE ELASTOMER PER MIL-DTL-83528 TYPE C, GRAY.
- E. INSERT HIGH GRADE POLARYLENE THERMOPLASTIC, MOLDED
- F. INTERFACIAL SEAL FLUOROSILICONE PER MIL-DTL-25988
- G. KEYING PIN HIGH GRADE POLARYLENE THERMOPLASTIC, MOLDED
- H. PIN CONTACT COPPER ALLOY PER ASTM B139 / B139M
- I. PANEL WASHER STAINLESS STEEL PER SAE-AMS-QQ-S-763 OR ASTM B240, 300 SERIES
- J. KEYING PIN INSERT HIGH GRADE POLARYLENE THERMOPLASTIC, MOLDED

FINISH:

	APPLIES TO NICKEL PLATED CONNECTORS (STANDARD PLATING)	APPLIES TO CADMIUM PLATED CONNECTORS
A. SHELL	NICKEL PLATED PER SAE-AMS-C-26074 CLASS 3, GRADE B	CADMIUM PLATED PER SAE-AMS-QQ-P-416 OVER NICKEL UNDERPLATE
B. ADAPTER SCREW	PASSIVATED PER SAE-AMS-QQ-P-35	CADMIUM PLATED PER SAE-AMS-QQ-P-416
C. ADAPTER NUT	PASSIVATED PER SAE-AMS-QQ-P-35	CADMIUM PLATED PER SAE-AMS-QQ-P-416
D. PANEL WASHER	PASSIVATED PER SAE-AMS-QQ-P-35	CADMIUM PLATED PER SAE-AMS-QQ-P-416
E. PIN CONTACT	GOLD PLATED PER ASTM B488 TYPE 2, GRADE C	

DESIGN AND CONSTRUCTION:

THE CONNECTORS SPECIFIED HEREIN ARE PANEL MOUNTED RECEPTACLES WITH FIXED (NON-REMOVABLE) PIN INSERTS AND CONTACTS. THE CONNECTOR IS WITHOUT PROVISIONS FOR CABLE CLAMPS OR TERMINATION SEALS.

PERFORMANCE:

THESE CONNECTORS MEET THE APPLICABLE REQUIREMENTS OF TE CONNECTIVITY SPECIFICATION C-6111.

PERFORMANCE; SHELL BE IN ACCORDANCE WITH C-6111, EXCEPT AS FOLLOWS

- HUMIDITY
- ALTITUDE IMMERSION
- ALTITUDE - LOW TEMPERATURE
- FLUID IMMERSION

THE CONNECTOR TERMINATION END MUST BE SUITABLY PROTECTED FOR TESTING OR APPLICATION IN ANY OF THESE ENVIRONMENTS.

TABLE 3

PART NUMBER	WEIGHT MAXIMUM GRAMS
MTC100-BF1-P32	23.0
MTC100-BF2-P32	33.2

THE FOLLOWING TABLE CONSISTS OF WEIGHTS FOR THESE SPECIFIC PART NUMBERS



IF THIS DOCUMENT IS PRINTED IT BECOMES UNCONTROLLED. CHECK FOR THE LATEST REVISION.

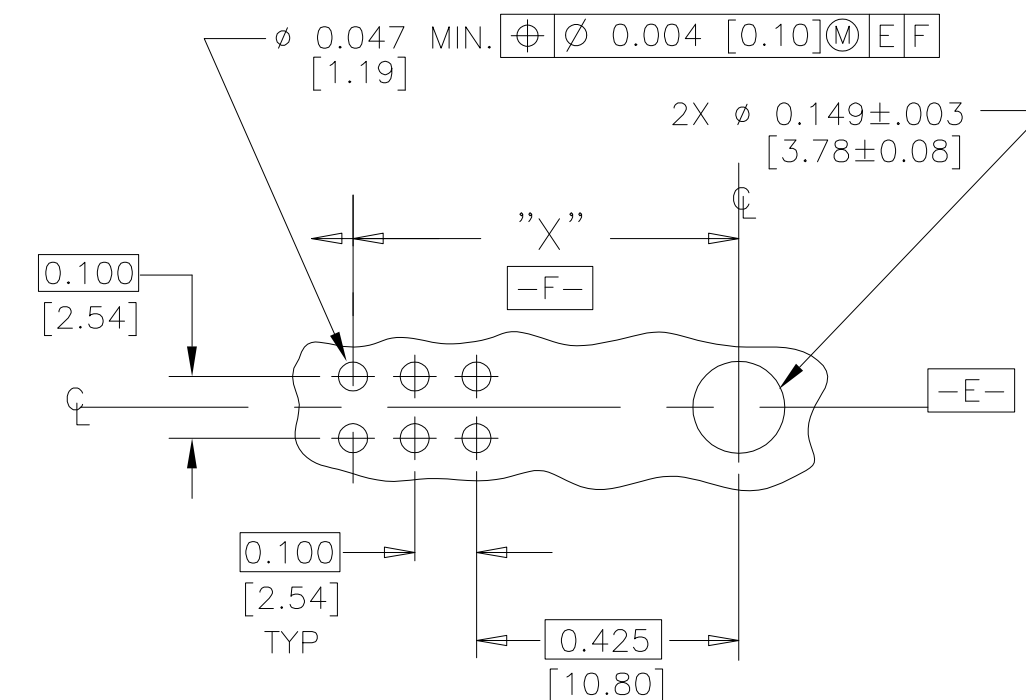

RECOMMENDED HOLE PATTERN AND SIZE FOR PRINTED CIRCUIT BOARDS

FIGURE 3

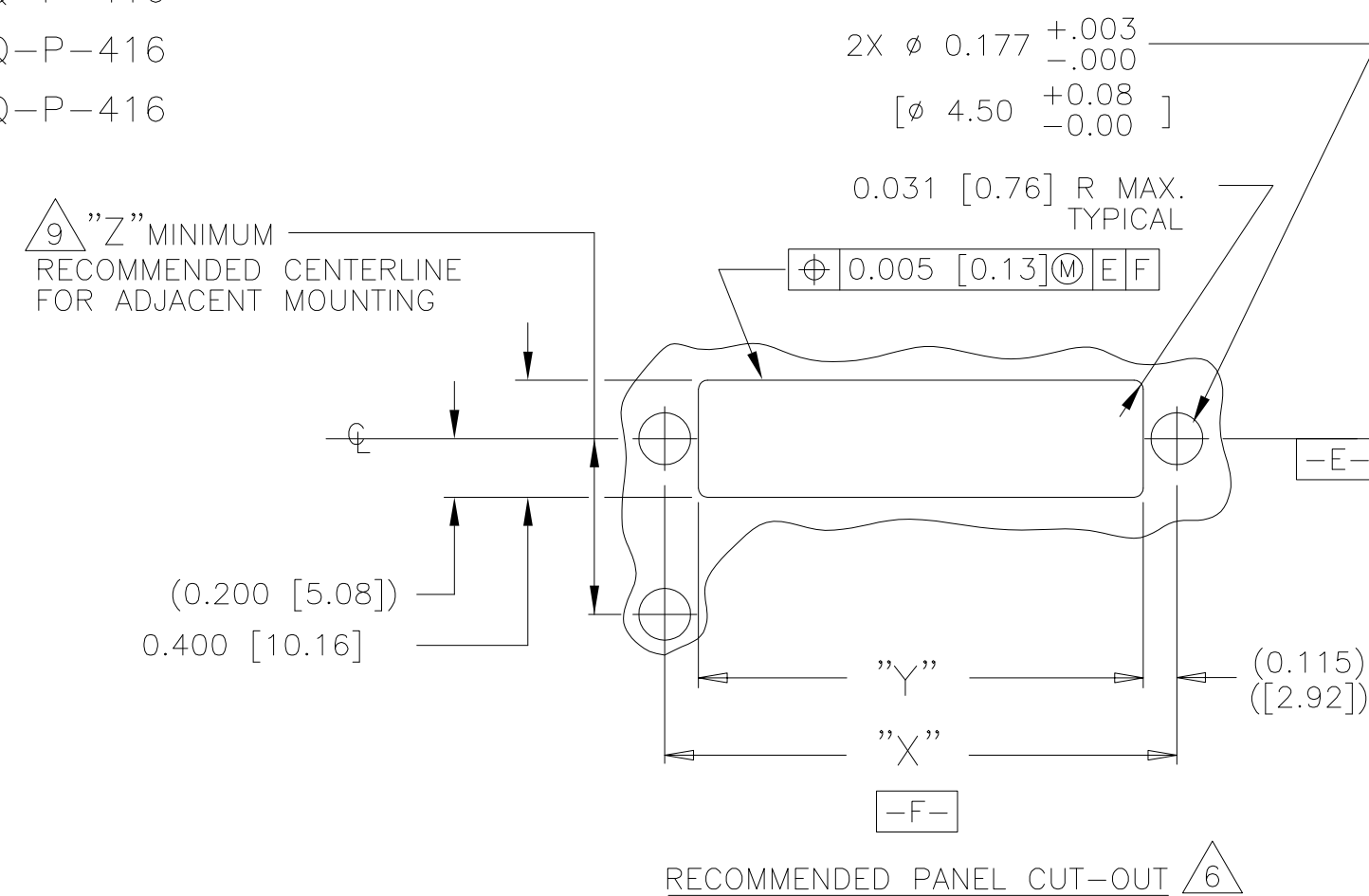

RECOMMENDED PANEL CUT-OUT

FIGURE 2

CUSTOMER DRAWING

SIZE C	CAGE CODE: 06090	DWG. NO. MTC100-BXX-PXX-XXX	REV J1
CAD NAME MTC100-BXX-PXX-XXX		SCALE: NONE	SHEET 3 OF 3

Компания «Океан Электроники» предлагает заключение долгосрочных отношений при поставках импортных электронных компонентов на взаимовыгодных условиях!

Наши преимущества:

- Поставка оригинальных импортных электронных компонентов напрямую с производств Америки, Европы и Азии, а так же с крупнейших складов мира;
- Широкая линейка поставок активных и пассивных импортных электронных компонентов (более 30 млн. наименований);
- Поставка сложных, дефицитных, либо снятых с производства позиций;
- Оперативные сроки поставки под заказ (от 5 рабочих дней);
- Экспресс доставка в любую точку России;
- Помощь Конструкторского Отдела и консультации квалифицированных инженеров;
- Техническая поддержка проекта, помощь в подборе аналогов, поставка прототипов;
- Поставка электронных компонентов под контролем ВП;
- Система менеджмента качества сертифицирована по Международному стандарту ISO 9001;
- При необходимости вся продукция военного и аэрокосмического назначения проходит испытания и сертификацию в лаборатории (по согласованию с заказчиком);
- Поставка специализированных компонентов военного и аэрокосмического уровня качества (Xilinx, Altera, Analog Devices, Intersil, Interpoint, Microsemi, Actel, Aeroflex, Peregrine, VPT, Syfer, Eurofarad, Texas Instruments, MS Kennedy, Miteq, Cobham, E2V, MA-COM, Hittite, Mini-Circuits, General Dynamics и др.);

Компания «Океан Электроники» является официальным дистрибьютором и эксклюзивным представителем в России одного из крупнейших производителей разъемов военного и аэрокосмического назначения «JONHON», а так же официальным дистрибьютором и эксклюзивным представителем в России производителя высокотехнологичных и надежных решений для передачи СВЧ сигналов «FORSTAR».



## JONHON

«JONHON» (основан в 1970 г.)

Разъемы специального, военного и аэрокосмического назначения:

(Применяются в военной, авиационной, аэрокосмической, морской, железнодорожной, горно- и нефтедобывающей отраслях промышленности)

«FORSTAR» (основан в 1998 г.)

ВЧ соединители, коаксиальные кабели, кабельные сборки и микроволновые компоненты:

(Применяются в телекоммуникациях гражданского и специального назначения, в средствах связи, РЛС, а так же военной, авиационной и аэрокосмической отраслях промышленности).



Телефон: 8 (812) 309-75-97 (многоканальный)

Факс: 8 (812) 320-03-32

Электронная почта: [ocean@oceanchips.ru](mailto:ocean@oceanchips.ru)

Web: <http://oceanchips.ru/>

Адрес: 198099, г. Санкт-Петербург, ул. Калинина, д. 2, корп. 4, лит. А