

Film Capacitor for AC Motor

Series : **DMF Series**



Features

- High safety (with built-in safety device)
- High reliability, Safety standard approval
- Small size, lightness, and low loss
- RoHS directive compliant

Recommended applications

- Motor and compressor (for running)

Construction

- Internal electrode : Metallized plastic film
- Exterior material : Metal case (oil sealing up type)
- Terminal : Faston terminal (tin plating)

Explanation of part number

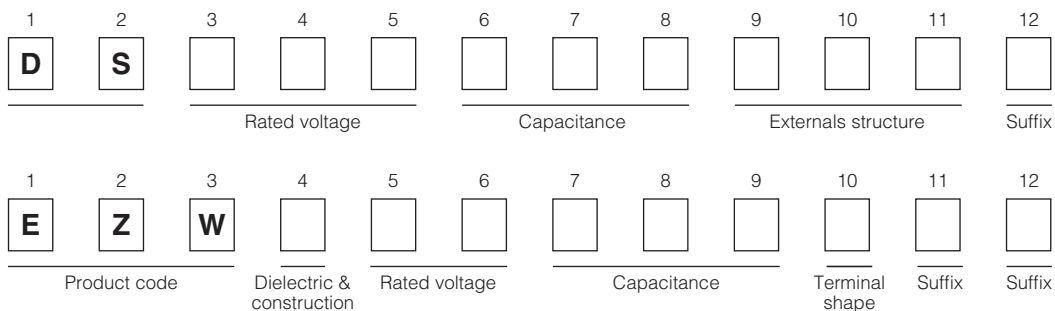

Applicable standard

Japan	JIS C 4908 Capacitors for electrical apparatus CMJ registration parts. Registration No.1475- C9902-026(JET)
UL/cUL	UL810/CSA C22.2 No. 190 FILE No. E76560
Europe	EN60252-1 AC motor Capacitors TUV
China	GB/T 3667.1 AC motor Capacitors CQC

Specifications

Applicable standard *1		JIS UL	EN GB
Safety class		With built-in safety device P1(CMJ approval) 10000 AFC (UL)	S2
Rated voltage (50/60 Hz) *2		180 V.AC to 450 V.AC	EN GB : 440 V.AC, 450 V.AC
Rated capacitance *2		10 μF to 60 μF	
Capacitance tolerance		-5 %/+10 %, ±5 % (Refer to the individual drawing)	
Withstand voltage	Between terminals	Rated voltage × 1.75, 60 s	Rated voltage × 2.0, 60 s
	Between terminals to enclosure	(min. 2000 V.AC) Rated voltage × 2.0+1000 (V.AC), 60 s	
Maximum permissible temperature (Case wall)		70 °C (Including self temperature rising)	

*1 The range of approval is different depending on each approval.

*2 These are typical values.

Dimension (Example)^{*3}

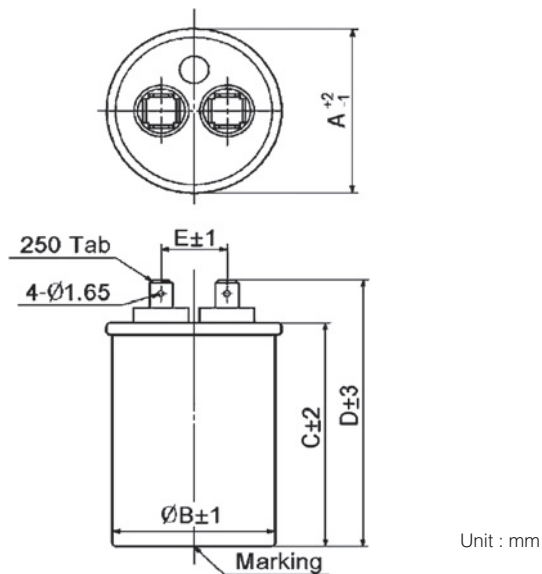

*3 Other shape and specific requirement can be designed. Please contact, if necessary.
Three tabs and as many as four tabs are also possible though standards of the number of terminal tabs are two tabs.

Rating · Dimensions^{*4}

Rated voltage (V.AC)	Capacitance (μF)	Dimensions (mm)				
		A	B	C	D	E
370 to 440	5.0 to 10.0	43.0	41.0	70.0	83.0	16.0
	11.0 to 15.0	43.0	41.0	80.0	93.0	16.0
	16.0 to 20.0	43.0	41.0	90.0	103.0	16.0
	21.0 to 25.0	43.0	41.0	100.0	113.0	16.0
	26.0 to 30.0	43.0	41.0	110.0	123.0	16.0
	31.0 to 35.0	43.0	41.0	130.0	143.0	16.0
	36.0 to 40.0	48.0	45.0	110.0	123.0	18.0
	41.0 to 50.0	48.0	45.0	130.0	143.0	18.0
	51.0 to 55.0	53.0	50.5	110.0	123.0	18.0
	56.0 to 60.0	63.0	60.5	90.0	103.0	20.0
	61.0 to 65.0	63.0	60.5	100.0	113.0	20.0

Rated voltage (V.AC)	Capacitance (μF)	Dimensions (mm)				
		A	B	C	D	E
450	5.0 to 10.0	43.0	41.0	70.0	83.0	16.0
	11.0 to 15.0	43.0	41.0	90.0	103.0	16.0
	16.0 to 20.0	43.0	41.0	110.0	123.0	16.0
	21.0 to 25.0	48.0	45.0	100.0	113.0	18.0
	26.0 to 30.0	48.0	45.0	110.0	123.0	18.0
	31.0 to 35.0	53.0	50.5	100.0	113.0	18.0
	36.0 to 40.0	53.0	50.5	110.0	123.0	18.0
	41.0 to 50.0	63.0	60.5	100.0	113.0	20.0
	51.0 to 55.0	63.0	60.5	110.0	123.0	20.0
	56.0 to 60.0	63.0	60.5	130.0	143.0	20.0

*4 Please contact if necessary other Voltage and Capacitance.

Guidelines and precautions regarding the technical information and use of our products described in this online catalog.

- If you want to use our products described in this online catalog for applications requiring special qualities or reliability, or for applications where the failure or malfunction of the products may directly jeopardize human life or potentially cause personal injury (e.g. aircraft and aerospace equipment, traffic and transportation equipment, combustion equipment, medical equipment, accident prevention, anti-crime equipment, and/or safety equipment), it is necessary to verify whether the specifications of our products fit to such applications. Please ensure that you will ask and check with our inquiry desk as to whether the specifications of our products fit to such applications use before you use our products.
- The quality and performance of our products as described in this online catalog only apply to our products when used in isolation. Therefore, please ensure you evaluate and verify our products under the specific circumstances in which our products are assembled in your own products and in which our products will actually be used.
- If you use our products in equipment that requires a high degree of reliability, regardless of the application, it is recommended that you set up protection circuits and redundancy circuits in order to ensure safety of your equipment.
- The products and product specifications described in this online catalog are subject to change for improvement without prior notice. Therefore, please be sure to request and confirm the latest product specifications which explain the specifications of our products in detail, before you finalize the design of your applications, purchase, or use our products.
- The technical information in this online catalog provides examples of our products' typical operations and application circuits. We do not guarantee the non-infringement of third party's intellectual property rights and we do not grant any license, right, or interest in our intellectual property.
- If any of our products, product specifications and/or technical information in this online catalog is to be exported or provided to non-residents, the laws and regulations of the exporting country, especially with regard to security and export control, shall be observed.

<Regarding the Certificate of Compliance with the EU RoHS Directive/REACH Regulations>

- The switchover date for compliance with the RoHS Directive/REACH Regulations varies depending on the part number or series of our products.
- When you use the inventory of our products for which it is unclear whether those products are compliant with the RoHS Directive/REACH Regulation, please select "Sales Inquiry" in the website inquiry form and contact us.

We do not take any responsibility for the use of our products outside the scope of the specifications, descriptions, guidelines and precautions described in this online catalog.

PRECAUTION AND WARNING

- Please consult us in case that demand the specification of our company without fail and do the confirmation of the use condition and that exceeds the entry value and be indistinct when you use it.
- The film capacitors contain a film based dielectric which may be flammable under certain operating conditions. When in use, they can either emit smoke and/or ignite should the product be defective. It is recommended covering the surrounding resin with flame-resistant materials or case as needed particularly.
- In the event of troubles of other parts on the circuit such as shortening and opening, provide with proper means for preventing excessive voltage, current or temperature exceeding the rating from being applied to the film capacitor.
- Prior to use, please make sure that failure of the film capacitors does not have any negative effects on other surrounding electronic circuit components and devices that would possibly cause damage. Proper safety measures should be taken using fail-safe protective circuit designs to help prevent other devices of becoming unsafe.

Example:

- a. State in which basic performance of automobiles (run, turn and stop)
 - b. False operations
 - c. Smoke emission/ignitions
- The Film Capacitor listed in this catalog(except for automotive series) are designed and manufactured specifically for general electronic devices, including audio-video equipment, home appliance, office equipment and data communication equipment etc.. Accordingly, it is strongly recommended that the user contact us in advance if the parts are to be used for the following devices(items 1 -12), which require having advanced security measures. The capacitor for automotive can be used for automobiles such as xEV.
 - (1) Transport Equipment (motor vehicles, airplanes, trains, ships, traffic signal controllers)
 - (2) Medical Equipment (life-support equipment, pacemakers for the heart, dialysis controllers)
 - (3) Aircraft Equipment, Aerospace Equipment (airplanes, artificial satellites, rockets, etc.)
 - (4) Submarine Equipment (submarine repeating equipment, etc.)
 - (5) Generation Control Equipment (equipment for atomic/hydraulic/heat power plants)
 - (6) Information Processing Equipment (large scale computer system)
 - (7) Electric Heating Appliance, Burning Apparatus
 - (8) Rotary Motion Equipment
 - (9) Security Systems
 - (10) Robots
 - (11) Lighting Equipment
 - (12) And any similar types of equipment
 - If used in a specific appliance that requires an extremely high reliability directly relating with any life-supporting equipment like electronic aviation controllers, automotive driving controllers and engine controllers, please consult us and use within the conditions designated in the specification. However the chip type capacitor should not be used in these appliances.

Note:

1. Technical information in this catalog is intended to convey examples of typical performances and/or applications, and is not intended to convey patents rights, if any.
2. For the products, which are controlled items subject to the Foreign Exchange and Foreign Trade Control Law, the export permission according to the Law is necessary.
3. Note of ozone depleting substances of class1 (ODS) under the Montreal Protocol is used in manufacturing process of Device Solutions Business Division, Panasonic Corporation.

Mouser Electronics

Authorized Distributor

Click to View Pricing, Inventory, Delivery & Lifecycle Information:

[Panasonic:](#)

[DS371156-CA](#)

Компания «Океан Электроники» предлагает заключение долгосрочных отношений при поставках импортных электронных компонентов на взаимовыгодных условиях!

Наши преимущества:

- Поставка оригинальных импортных электронных компонентов напрямую с производств Америки, Европы и Азии, а так же с крупнейших складов мира;
- Широкая линейка поставок активных и пассивных импортных электронных компонентов (более 30 млн. наименований);
- Поставка сложных, дефицитных, либо снятых с производства позиций;
- Оперативные сроки поставки под заказ (от 5 рабочих дней);
- Экспресс доставка в любую точку России;
- Помощь Конструкторского Отдела и консультации квалифицированных инженеров;
- Техническая поддержка проекта, помощь в подборе аналогов, поставка прототипов;
- Поставка электронных компонентов под контролем ВП;
- Система менеджмента качества сертифицирована по Международному стандарту ISO 9001;
- При необходимости вся продукция военного и аэрокосмического назначения проходит испытания и сертификацию в лаборатории (по согласованию с заказчиком);
- Поставка специализированных компонентов военного и аэрокосмического уровня качества (Xilinx, Altera, Analog Devices, Intersil, Interpoint, Microsemi, Actel, Aeroflex, Peregrine, VPT, Syfer, Eurofarad, Texas Instruments, MS Kennedy, Miteq, Cobham, E2V, MA-COM, Hittite, Mini-Circuits, General Dynamics и др.);

Компания «Океан Электроники» является официальным дистрибьютором и эксклюзивным представителем в России одного из крупнейших производителей разъемов военного и аэрокосмического назначения «JONHON», а так же официальным дистрибьютором и эксклюзивным представителем в России производителя высокотехнологичных и надежных решений для передачи СВЧ сигналов «FORSTAR».



JONHON

«JONHON» (основан в 1970 г.)

Разъемы специального, военного и аэрокосмического назначения:

(Применяются в военной, авиационной, аэрокосмической, морской, железнодорожной, горно- и нефтедобывающей отраслях промышленности)

«FORSTAR» (основан в 1998 г.)

ВЧ соединители, коаксиальные кабели, кабельные сборки и микроволновые компоненты:

(Применяются в телекоммуникациях гражданского и специального назначения, в средствах связи, РЛС, а так же военной, авиационной и аэрокосмической отраслях промышленности).



Телефон: 8 (812) 309-75-97 (многоканальный)

Факс: 8 (812) 320-03-32

Электронная почта: ocean@oceanchips.ru

Web: <http://oceanchips.ru/>

Адрес: 198099, г. Санкт-Петербург, ул. Калинина, д. 2, корп. 4, лит. А