

SINGLE PHASE FULL WAVE PWM MOTOR DRIVER

NEW PRODUCT

Description

The AM4961A is highly integrated feature rich single phase Brushless Direct Current (BLDC) full wave motor driver with PWM control function for fans, blowers and extractors.

For system flexibility the motor speed can be controlled by either an external PWM signal or by a DC voltage or from a Thermistor network. Based on the input signal, the AM4961A adjust the output duty cycle.

To help protect the motor coil, the AM4961A provides a rotor lock protection which shuts down the output if rotor lock is detected. The device automatically re-starts when the rotor lock is removed.

To help interface to external system for monitoring the motor status and speed, AM4961A provides open drain Rotor lock detect alarm output (RD) pin and a tachometer output Frequency Generator (FG). The FG output is the magnetic change frequency.

The AM4961A is available in SSOP-16 and HTSSOP-14 packages.

Features

- Operating voltage : 3.5V to 16V
- Internal H-Bridge with 1A Peak Current Capability
- Speed Control with external PWM, DC or Thermistor signals
- Minimal Speed Setting
- Built-in Hall Bias Circuit
- Reference Voltage Output
- Rotor Lock Protection with Output Shutdown and Auto Restart
- Rotation Speed Indication (FG)
- Rotation or Lock State Indication (RD)
- Built-in Thermal Shutdown Circuit
- Industry standard SSOP-16 and Thermally Enhanced HTSSOP-14 Packages
- **Totally Lead-Free & Fully RoHS Compliant (Notes 1 & 2)**
- **Halogen and Antimony Free. "Green" Device (Note 3)**

Notes: 1. No purposely added lead. Fully EU Directive 2002/95/EC (RoHS) & 2011/65/EU (RoHS 2) compliant.
 2. See http://www.diodes.com/quality/lead_free.html for more information about Diodes Incorporated's definitions of Halogen- and Antimony-free, "Green" and Lead-free.
 3. Halogen- and Antimony-free "Green" products are defined as those which contain <900ppm bromine, <900ppm chlorine (<1500ppm total Br + Cl) and <1000ppm antimony compounds.

Pin Assignments

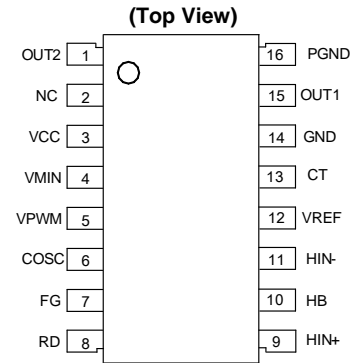

SSOP-16 (GS Package)

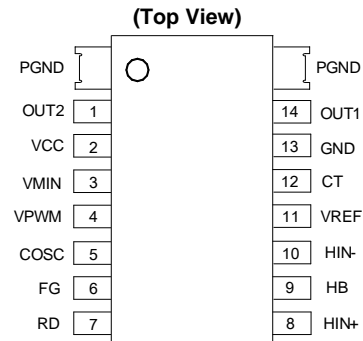

HTSSOP-14 (GH Package)

Applications

- 12V BLDC Cooling Fans, Motors, Extractors and Blowers
- CPU Cooler Fan in PC
- Instrumentation and Equipment Cooling fans
- Brushless DC Motor Driver

Typical Applications Circuit

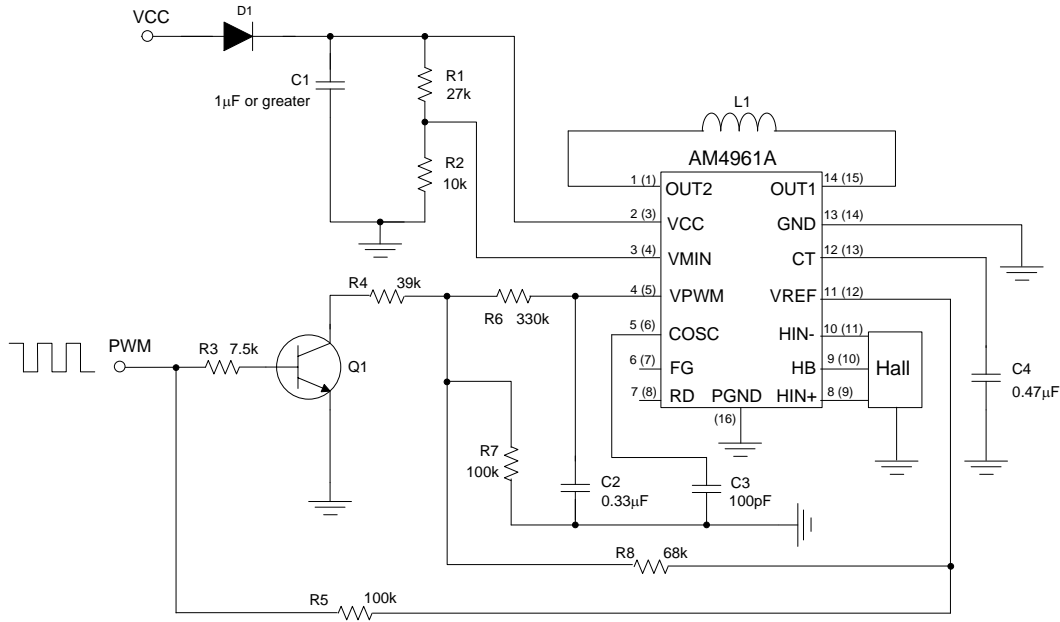

Typical Application Circuit with an External Input PWM Speed Control Signal

Note: 4. C1 is for power stabilization and should be 1µF or higher depending on the motor current and motor design.

Pin Descriptions

Package: HTSSOP-14 and SSOP16

Pin Number		Pin Name	Function
HTSSOP-14	SSOP-16		
1	1	OUT2	Drive output 2
-	2	NC	No connection
2	3	VCC	Power supply
3	4	VMIN	Minimum duty setting
4	5	VPWM	Adjustable input
5	6	COSC	Oscillator capacitor
6	7	FG	Rotation speed indicator
7	8	RD	Rotation/lock state indicator
8	9	HIN+	Hall sensor input+
9	10	HB	Hall sensor bias regulator
10	11	HIN-	Hall sensor input-
11	12	VREF	Reference voltage regulator
12	13	CT	Lock and rotation setting capacitor terminal
13	14	GND	Ground for control circuit
14	15	OUT1	Drive output 1
-	16	PGND	Power ground

Functional Block Diagram

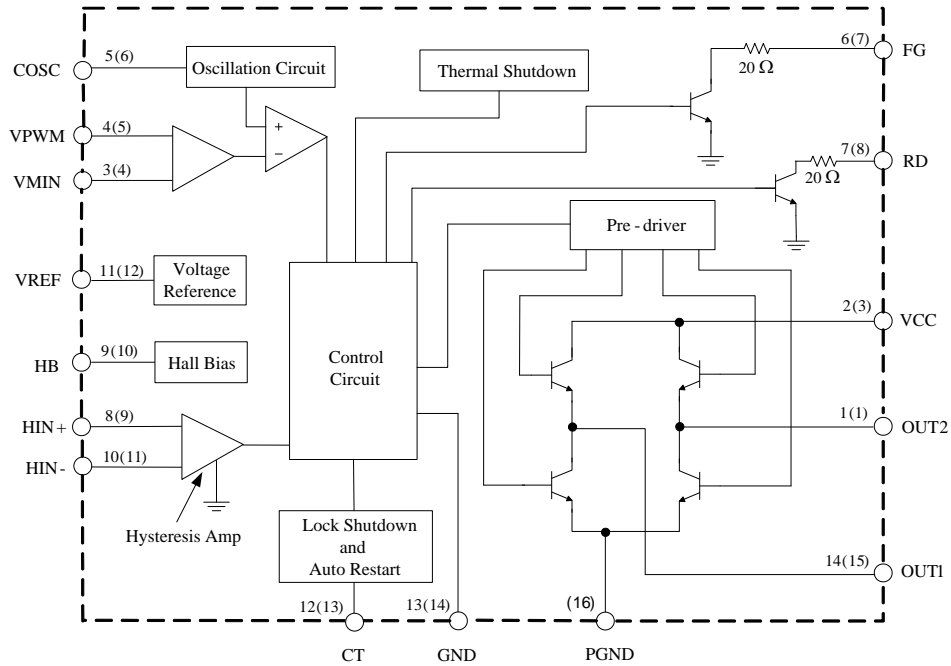

A (B): A for HTSSOP-14 pins B for SSOP-16 pins

Truth Table

HIN-	HIN+	COSC (Note 5)	CT	OUT1	OUT2	FG	RD	Mode			
H	L	H	L	H	L	L	L	Rotation (Drive)			
L	H			L	H	OFF					
H	L	L		H	OFF	L		L	OFF	Rotation (Recirculate)	
L	H				L	OFF		OFF			
H	L	H	H		H	OFF	L	OFF		Lock Protection	
L	H				OFF	H	OFF				
H	L	L		H	OFF	OFF	L		OFF		Lock Protection
L	H				OFF	OFF	OFF				

Note: 5. $V_{OSC(H)} > V_{PWM}$, $V_{OSC(L)} < V_{PWM}$.

Absolute Maximum Ratings (Note 6) (@T_A = +25°C, unless otherwise specified.)

Symbol	Parameter	Rating	Unit	
V _{CC}	Supply Voltage	18	V	
I _{OUT}	Output Current	1.0	A	
V _{OUT}	Output Voltage	18	V	
I _{HB}	HB Output Current	10	mA	
V _{PWM}	VPWM Input Voltage	6	V	
V _{RD}	RD Output Voltage	18	V	
V _{FG}	FG Output Voltage	18	V	
I _{RD}	RD Output Current	10	mA	
I _{FG}	FG Output Current	10	mA	
P _D	Power Dissipation (Note 7)	SSOP-16	0.8	W
		HTSSOP-14	1.1	
T _{STG}	Storage Temperature Range	-55 to +150	°C	
ESD	ESD (Human Body Model)	2000	V	
ESD	ESD (Machine Model)	250	V	

Notes: 6. Stresses greater than those listed under "Absolute Maximum Ratings" may cause permanent damage to the device. These are stress ratings only, and functional operation of the device at these or any other conditions beyond those indicated under "Recommended Operating Conditions" is not implied. Exposure to "Absolute Maximum Ratings" for extended periods may affect device reliability

7. T_A = +25°C, no external heatsink.

Recommended Operating Conditions

Symbol	Parameter	Conditions	Min	Typ	Max	Unit
V _{CC}	Supply Voltage	Operating	3.5	12	16	V
V _{IN+}	Hall Input Voltage + (Note 8)	—	0.2	—	3	V
V _{IN-}	Hall Input Voltage - (Note 8)	—	0.2	—	3	V
T _A	Ambient Temperature	—	-30	—	+90	°C

Note: 8. Hall input voltage range includes the amplitude of signal.

Electrical Characteristics (@V_{CC}=12V, T_A=25°C, unless otherwise specified.)

Symbol	Parameter	Conditions	Min	Typ	Max	Units
I _{Q1}	Quiescent Current	Lock Off	10.2	15	18.76	mA
I _{Q2}		Lock On	5.38	8	10.55	
V _{REF}	VREF Voltage	I _{REF} = 5mA	5.8	6	6.2	V
V _{SATH}	Output Saturation Voltage at High Side	I _{SOURCE} = 200mA	–	1.0	1.17	V
V _{SATL}	Output Saturation Voltage at Low Side	I _{SINK} = 200mA	–	0.2	0.3	V
f _{OSC}	COSC Frequency	C _{OSC} = 100pF	18	25	32	kHz
V _{OSCH}	COSC High Level Voltage	–	3.45	3.6	3.75	V
V _{OSCL}	COSC Low Level Voltage	–	1.83	1.95	2.07	V
V _{HYS}	Hall Input Hysteresis	–	–	±10	±20	mV
V _{HB}	Hall Bias Voltage	I _{HB} = 5mA	1.1	1.25	1.4	V
V _{CTH}	CT High Level Voltage	–	3.55	3.7	3.88	V
V _{CTL}	CT Low Level Voltage	–	1.55	1.7	1.85	V
I _{CHG}	CT Charge Current	–	1.5	2	2.85	μA
I _{DHG}	CT Discharge Current	–	0.14	0.2	0.285	μA
R _{CD}	CT Charge and Discharge Ratio	I _{CHG} /I _{DHG}	8.5	10	14.5	–
V _{FG} L	FG Output Low Level Voltage	I _{FG} = 5mA	–	0.3	0.4	V
I _{LF} G	FG Leakage Current	V _{FG} = 12V	–	–	30	μA
V _{RD} L	RD Output Low Level Voltage	I _{RD} = 5mA	–	0.3	0.4	V
I _{LR} D	RD Leakage Current	V _{RD} = 12V	–	–	30	μA

Functional Descriptions

H-Bias – Hall Bias Output

This is a 1.25V nominal voltage source to bias a differential un-buffered Hall element sensor. If a Hall element requires a lower voltage than the H-Bias output, connect an appropriate value resistor between the H-Bias pin and the Hall element supply pin.

H+ and H- – Hall Inputs

The rotor position is detected by a Hall sensor, with the output applied to the H+ and H- pins. This sensor can be either a 4 pin 'naked' Hall device or of the 3 pin buffered switching type. For a 4 pin device the differential Hall output signal is connected to the H+ and H- pins. For a buffered Hall sensor the Hall device output is attached to the H+ pin, with a pull-up attached if needed, whilst the H- pin has an external potential divider attached to hold the pin at half Vref. When H+ is high in relation to H-, out2 is the active drive.

VREF – Output Reference Voltage

This is a 6V nominal reference output voltage. It is designed to 'source' current and therefore it will not 'sink' any current from a higher voltage. The total current drawn from the VREF pin by any external circuitry, such as the minimum speed potential divider to VMIN pin, should not exceed 5mA.

COSC Pin

A capacitor at the COSC pin generates a triangular waveform which is compared with VPWM (or VMIN) to generate output Pulse Width Modulated (PWM) drive for speed control. A capacitor of 100pf capacitor connected between COSC and ground a 25 kHz triangle wave with high level voltage is 0.3VCC typical and low level voltage of 0.16VCC typical. For 12V supply, the high and low level thresholds are 3.6V and 1.95V.

VPWM - Speed control Input

The voltage applied to the VPWM pin provides control of the motor speed by varying the PWM drive ratio at the out1 and out2 outputs. The control signal should be a variable DC voltage input of range 3.6V to 1.95V for nominal 12V supply, representing 0% to 100% drive respectively. If variable speed control is not required this pin can be tied to an external potential divider to set a fixed speed or tied to ground to provide full speed i.e. 100% PWM drive. If external input PWM signal is used to control the speed, this input PWM signal needs to be converted to a DC voltage to meet the VPWM pin input range.

VMIN – Minimum Speed Setting

A voltage can be set on this pin via a potential divider between the VREF (or Supply) and GND pins. This voltage is monitored by the VPWM pin to clamp the VPWM control voltage so that it does not rise above VMIN voltage. As a higher voltage on the VPWM pin represents a lower speed, the VMIN setting prevents the motor speed going lower than the minimum speed set by the VMIN pin. When the VMIN voltage is higher than the lowest speed setting voltage allowed (The lowest speed voltage is about 0.28VCC), the fan speed is maintained at the at the lowest speed.

CT Pin – Locked Rotor Timing Capacitor

The CT pin will have a capacitor connected to ground. It is a multi-function pin providing timing for the lock detect and auto-restart. Different rates of charge and discharge of CT capacitor depending on the mode of operation (fan operation status) give the lock-detect time (T_{LCKDET}) and lock time (T_{OFF}) before next auto-start retry. When the motor is running, the capacitor is discharged at every Hall signal change.

CT pin provides the timing for the Locked Rotor monitor. In normal operation, Lock Detect is enabled. If the Hall signal does not change (i.e. a rotor lock condition) within the Lock Detect time (T_{LCKDET}), the outputs are disabled. In this condition the motor will not be driven for a set time T_{OFF} . This T_{OFF} time depends on the external CT capacitor value and its internal discharge current (I_{DHG}). After the T_{OFF} period device enter auto-restart phase to re-start the motor with a new Lock Detect time. If the motor has not turned to generate a transition on the Hall inputs by the end this T_{LCKDET} period, motor re-enters motor lock T_{OFF} period with outputs disabled. If the Hall signal change is detected, the motor is deemed as running and goes into lock-detection mode. The T_{LCKDET} and T_{OFF} are determined by the value of the external capacitor on the CT pin and the internal charge and discharge currents during these time periods. The currents during, T_{LCKDET} and T_{OFF} are I_{CHG} , and I_{DHG} respectively.

FG – Frequency Generator (Tachometer) Output

This is the Frequency Generator output and is a buffered signal from the Hall sensor. This is an open collector drive giving an active pull down with the high level being provided by an external pull up resistor.

Functional Descriptions

RD Pin

This is the fan locked status detector. This is an open collector drive giving an active pull down with the high level being provided by an external pull up resistor. When fan is locked, RD pin is in off state.

Out1 and Out2 pin

Out1 and out2 pins provide H-bridge driver output for fan and motor coil connection.

V_{CC} – I_C Supply Voltage

This provides the supply for the device.

GND – Supply Return

This is the device supply ground return pin for control signal.

PGND –Power Supply Return

This is the device supply ground return pin for power output pin out1 and out2 will generally be the most negative supply pin to the fan.

Performance Characteristics

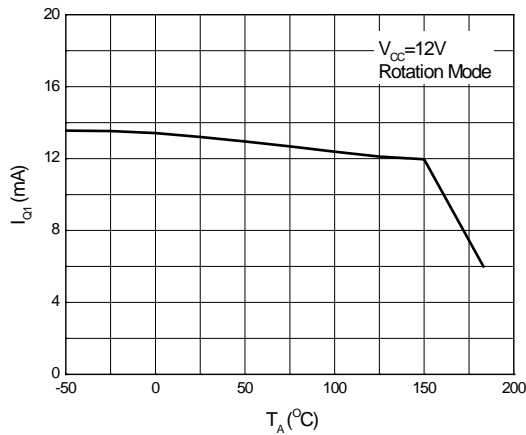

Quiescent Current vs. Ambient Temperature

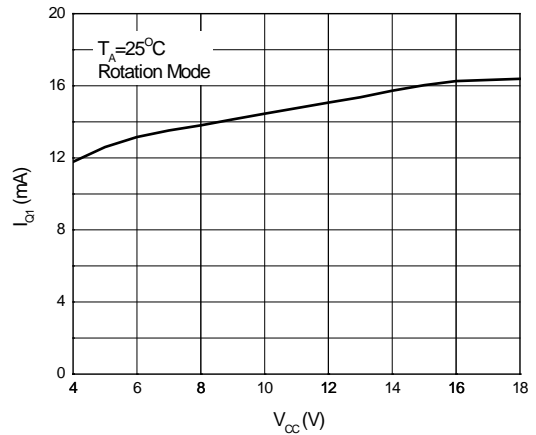

Quiescent Current vs. Supply Voltage

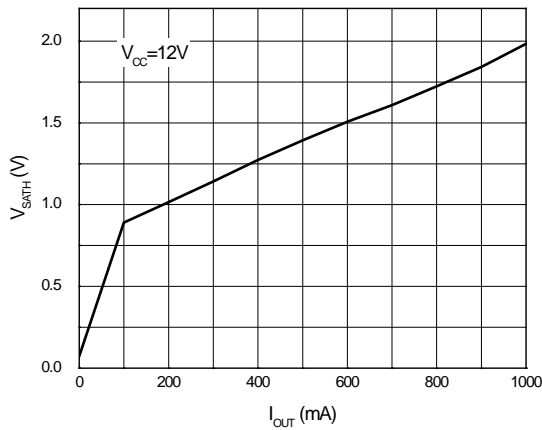

Output Saturation Voltage (High) vs. Output Current

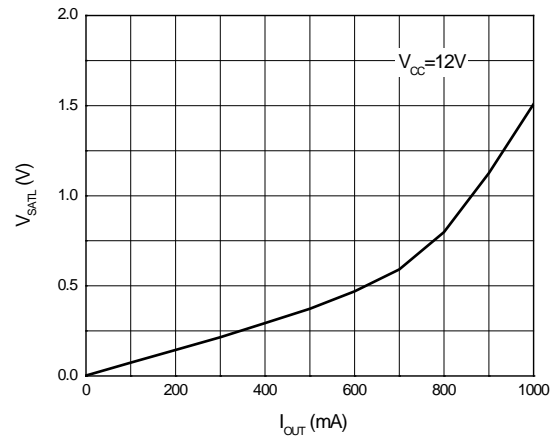

Output Saturation Voltage (Low) vs. Output Current

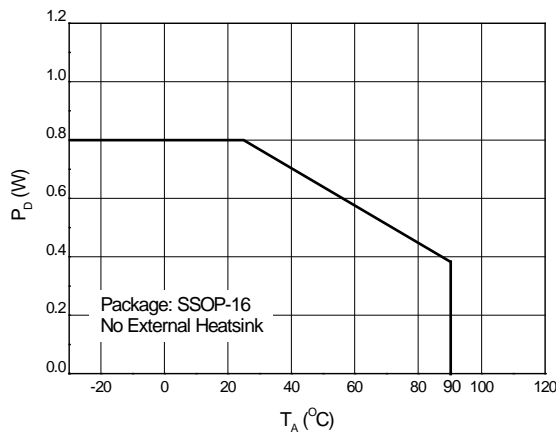

Power Dissipation vs. Ambient Temperature

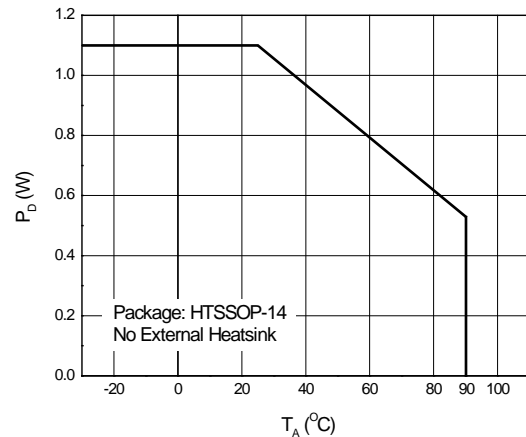

Power Dissipation vs. Ambient Temperature

Applications Note

Typical Application Circuit for PWM input signal for speed control with AM4961A is shown below. The speed is primarily controlled by a voltage on the VPWM pin (either from DC voltage signal or PWM inputs signal converted to DC voltage) or alternatively a PWM signal on COSC pin.

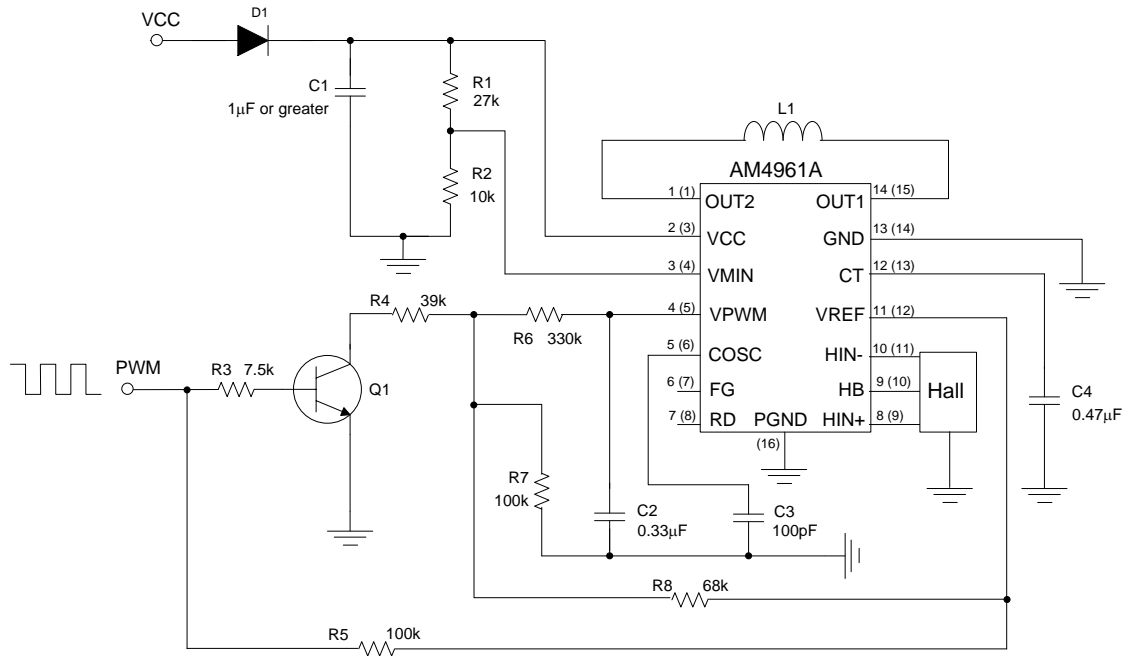

Typical Application Circuit – External PWM Input Speed Control

Note: 9. C1 is for power stabilization and should be 1 μ F or higher depending on the motor current and motor design.

Power Supply Stabilization

The recommended operating voltage range for AM4961A is 3.5V to 16V. A decoupling capacitor C1 (which also acts as re-circulating capacitor at commutation) should be connected close to the V_{CC} pin. C1 is for power stabilization and should be 1 μ F or higher depending on the motor current and motor design.

Hall Bias and Hall Input for Commutation Signal

The HB pin provides a 1.25V Hall bias voltage to drive Hall element. The output of the Hall elements or the Hall switches connect to Hall input H+ and H- pin as described previously in functional description section. To avoid noise, the connection to the Hall element or switch should be as short as possible. The Hall input stage (H+ and H- pin) has a hysteresis of 20mV typical. The differential Hall input signal should be 50mV peak or higher.

Output PWM Frequency Setting – CSOSC Capacitor

The output PWM frequency is generated by comparing VPWM or VMIN (whichever is lower) to the triangular wave on the COSC pin. See “Speed Control and Minimum Speed Setting” figure.

The triangular wave is generated at the COSC pin when a capacitor C3 is connected between it and the ground. The triangular wave has high level of 0.3V_{CC} typical and low level voltage of 0.16V_{CC} typical. For 12V nominal supply these two levels are 3.6V and 1.95V typical. The capacitor C3 of 100pF at COSC pin provides output PWM frequency of 25kHz typical. The C3 capacitor should be connected close to the COSC pin.

Applications Note (cont.)

Speed Control

The motor speed is governed by the output PWM duty of the H-Bridge.

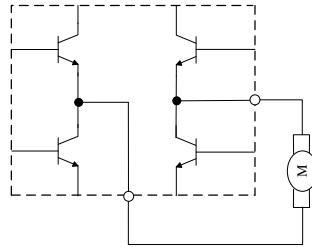

The voltage on the VPWM, VMIN pin and COSC pin controls the output PWM duty and therefore the speed of the motor. When the VPWM voltage is smaller than VMIN voltage, the output PWM duty is generated by comparing the triangular voltage at COSC pin with VPWM. If the VPWM pin voltage is higher than the VMIN pin, the speed is controlled by comparing COSC voltage with VMIN voltage. When the VPWM voltage is lower than the low side of the COSC voltage, the motor will run at full speed. See "Speed Control and Minimum Speed Setting" figure.

An input DC voltage from 3.6V to 1.9V (for 12V supply) on the VPWM pin controls the output PWM duty from 0% to 100% thus allowing speed control from 0% to 100% of the full speed. If variable speed control is not required the pin should be tied to an external voltage through a potential divider for a fixed speed or tied to ground for full speed (i.e. 100% output duty PWM drive). The potential divider for a fixed voltage can be supplied by the supply voltage (as shown in typical application circuit) or by the VREF provided the maximum current drawn out from the VREF pin is below 5mA.

For speed control based on ambient temperature, a thermistor can be used as one of the resistors in the potential divider.

If an external input PWM signal is used to control the motor speed, the input PWM signal can be converted to a DC level with transistor Q1, resistors R1 to R and an integrating capacitor C2. See typical application circuit.

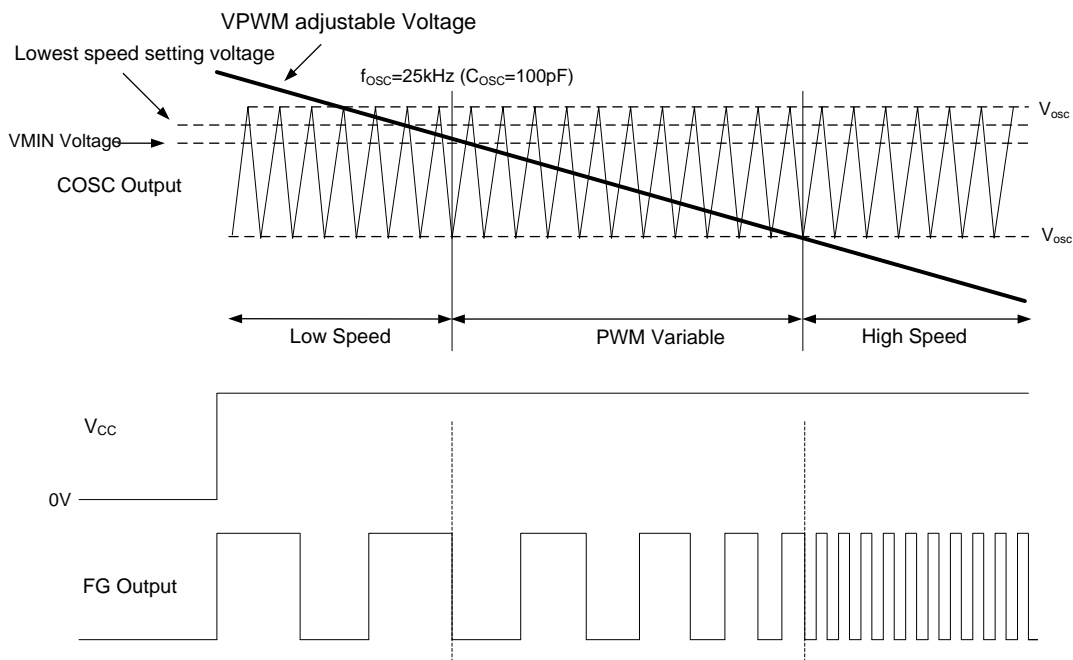

Speed Control and Minimum Speed Setting

Applications Note (cont.)

Minimum Speed Setting

The minimum speed setting prevents the motor speed dropping below a set speed when the speed demand is too low (i.e. VPWM voltage is closer to 3.6V)

When the VPWM pin voltage higher than the VMIN voltage, VMIN voltage is compared to the COSC pin to generate output PWM duty. Therefore, setting VMIN to certain fixed voltage forces the VMIN to control the speed even when the PWM voltage is higher.

The output PWM duty will be clamped to the PWM duty represented by the VMIN voltage when the speed demand is lower than the set minimum.

If VMIN is not used or application does not need to set the minimum speed, connect the VMIN to VPWM directly. When the VMIN is connected to the VPWM the minimum output PWM duty defaults to 10%.

Rotor Lock Detect and OFF time Setting

The capacitor C4 from CT pin to the ground provides the timing for the lock detect and auto-restart. The capacitor C4 is charges and discharged by the CT pin at a fixed rate depending on the mode of operation (fan operation status) and therefore the value of the C4 to gives lock-detect time (T_{LCKDET}) and lock time (T_{OFF}) before next auto-start retry.

The Am4961A returns the C4 voltage to the low threshold, V_{CTL} (1.77V), each time the Hall sensor provides the commutation signal. C4 is charged with I_{CHG} which is typically 2 μ A. If the voltage on the C4 reaches the high threshold, V_{CTH} (3.7V) before the next Hall signal change, the output will be shutdown and the device will enter lock condition.

$$T_{LCKDET} = \frac{C4 (V_{CTH} - V_{CTL})}{I_{CHG}}$$

The thresholds voltage and charge current are fixed, therefore the T_{LCKDET} time depends only on the value of C4.

$$T_{LCKDET} = C4 \times 1 \times 10^6$$

For C4 of 0.47 μ F, T_{LCKDET} is 0.47s

If lock detection causes device to enter output shutdown, the CT pin will discharge the C4 capacitor with I_{DHG} provide T_{OFF} period. The T_{OFF} is the time the device waits before next auto-restart. During T_{OFF} period, the C4 is discharged for the high threshold, V_{CTH} to low threshold V_{CTL} at the discharge current I_{DHG} which is typically 0.2 μ A.

$$T_{OFF} = \frac{C4 (V_{CTH} - V_{CTL})}{I_{DHG}}$$

The thresholds voltage and discharge current are fixed, therefore the T_{OFF} time depends only on the value of C4.

$$T_{OFF} = C4 \times 10 \times 10^6$$

For CT of 0.4 μ s, T_{OFF} is 4.7s before the next auto restart.

Thermal Shutdown

AM4961A includes a thermal shutdown function. When the device junction temperature is higher than 176 °C typical, the thermal shutdown function is triggered and the low side output transistors in H- bridge driver will be turned off. When the IC junction temperature drops below 148°C typical, the device will recover.

Applications Note (cont.)

Status Output - FG and RD Output

The FG output pin is an open collector output which switches ON (pulled low) and OFF (pulled high with an external resistor) depending on the magnetic phase of the motor. The external pull up resistor should be connected to the FG pin.

The RD output pin is also an open collector which switches ON (pulled low) while the motor rotates and switched off (pulled high with an external resistor) when the rotor is stopped.

The FG and RD pins have series resistors of 25Ω typical integrated in the FG/RD output structure to increased robustness against reverse supply connection of the FG an RD pins to ground. The typical value for external pull-up on FG and RD pins is 10kΩ.

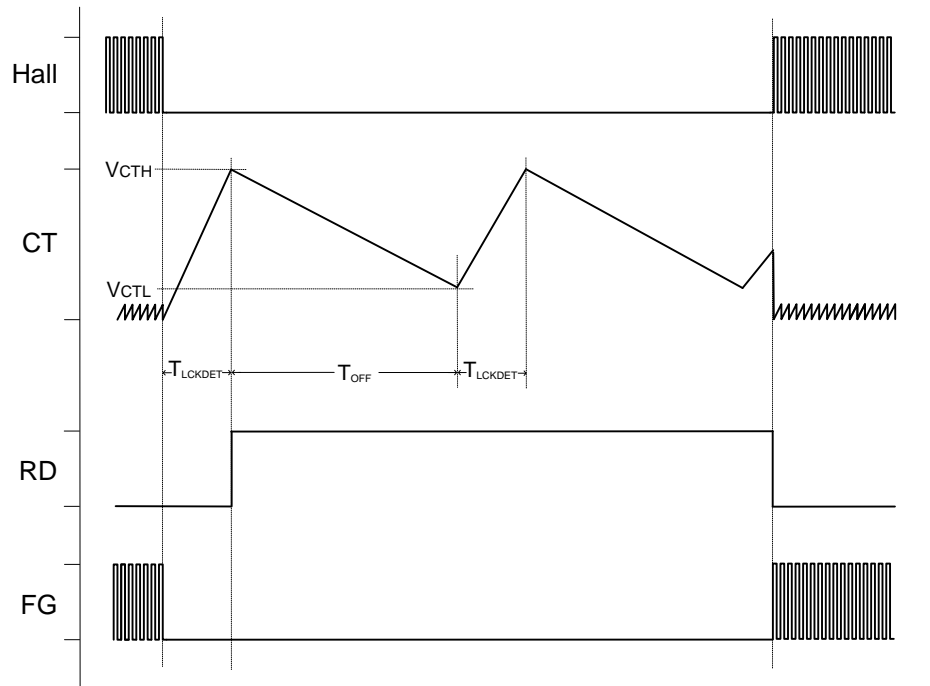

Ordering Information

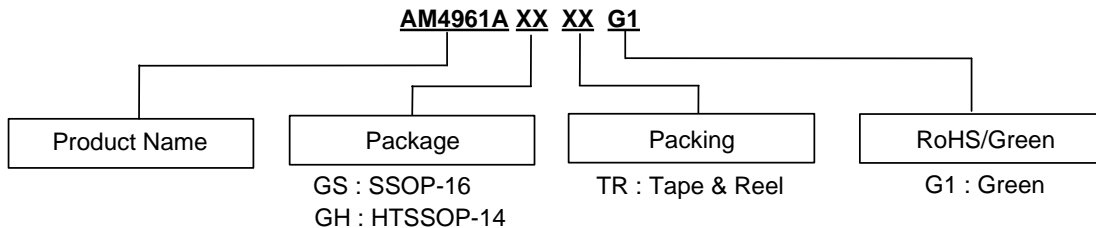

Diodes IC's Pb-free products with "G1" suffix in the part number, are RoHS compliant and green.

Part Number	Marking ID	Packaging	13" Tape and Reel
			Quantity
AM4961AGSTR-G1	AM4961GS-G1	SSOP-16	3000/Tape & Reel
AM4961AGHTR-G1	AM4961GH-G1	HTSSOP-14	3000/Tape & Reel

Package Outline Dimensions (All dimensions in mm(inch).)

(1) Package Type: SSOP-16

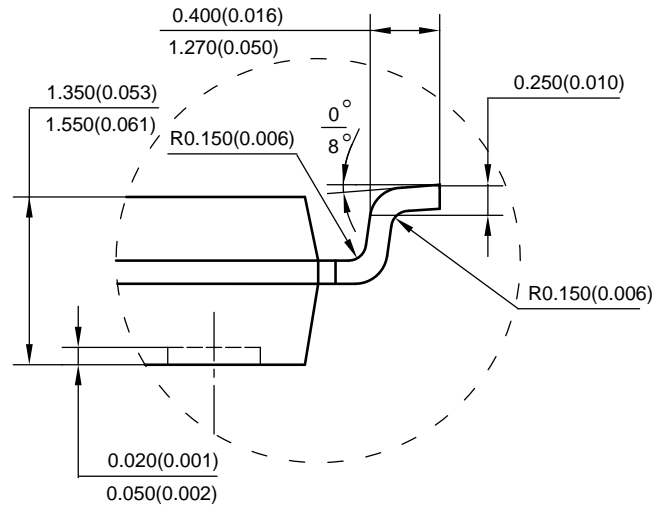
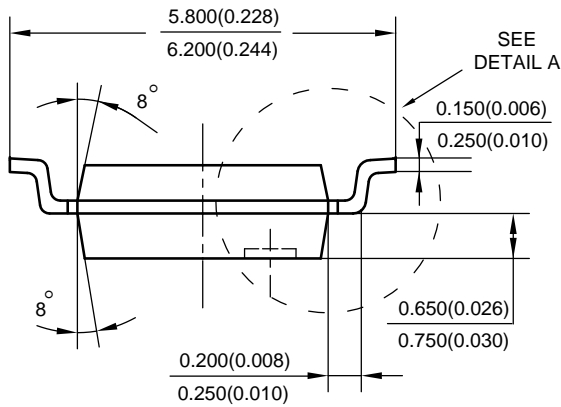
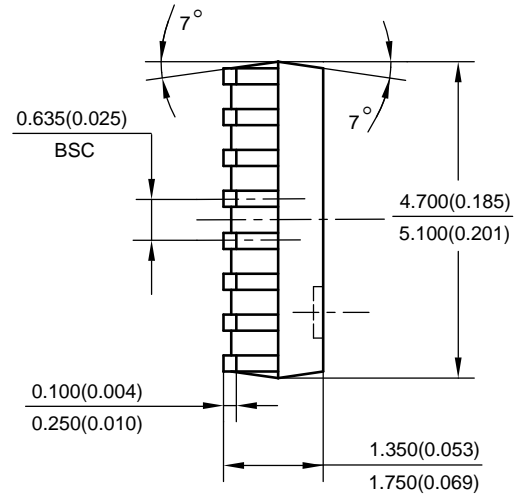
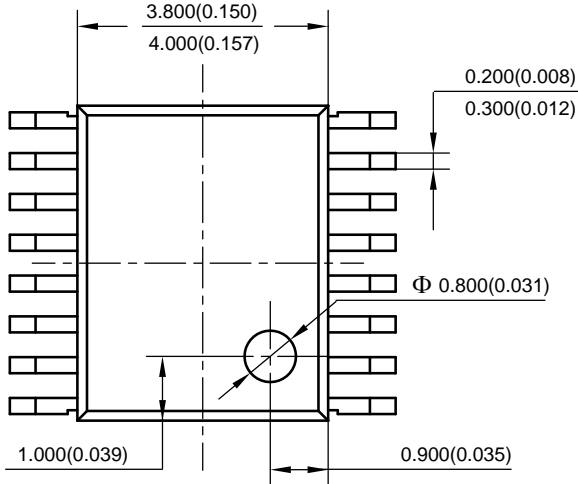

Note: Eject hole, oriented hole and mold mark is optional.

DETAIL A

Package Outline Dimensions (cont.) (All dimensions in mm(inch).)

(2) Package Type: HTSSO-14

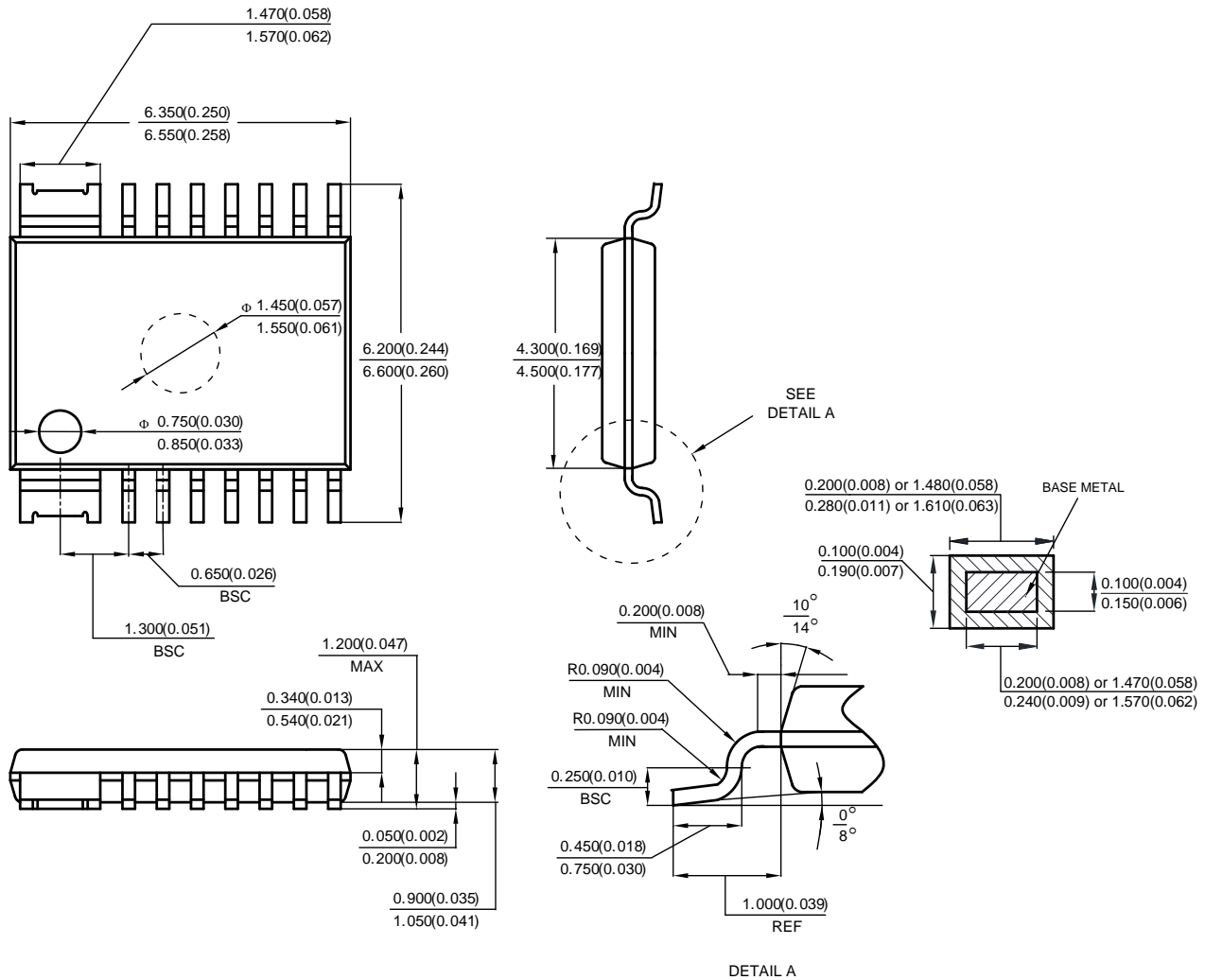

Note: Eject hole, oriented hole and mold mark is optional.

Suggested Pad Layout

(1) Package Type: SSOP-16

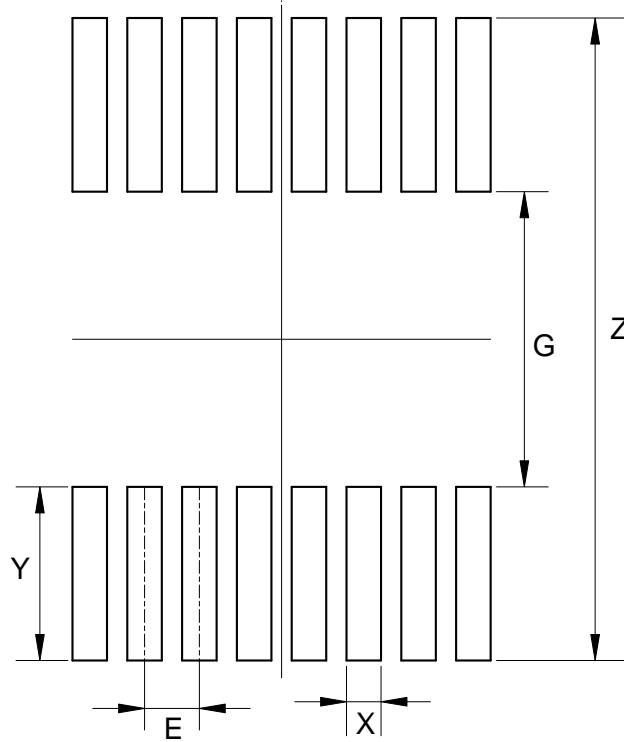

Dimensions	Z (mm)/(inch)	G (mm)/(inch)	X (mm)/(inch)	Y (mm)/(inch)	E (mm)/(inch)
Value	7.400/0.291	3.400/0.134	0.400/0.016	2.000/0.079	0.635/0.025

Suggested Pad Layout (cont.)

(2) Package Type: HTSSOP-14

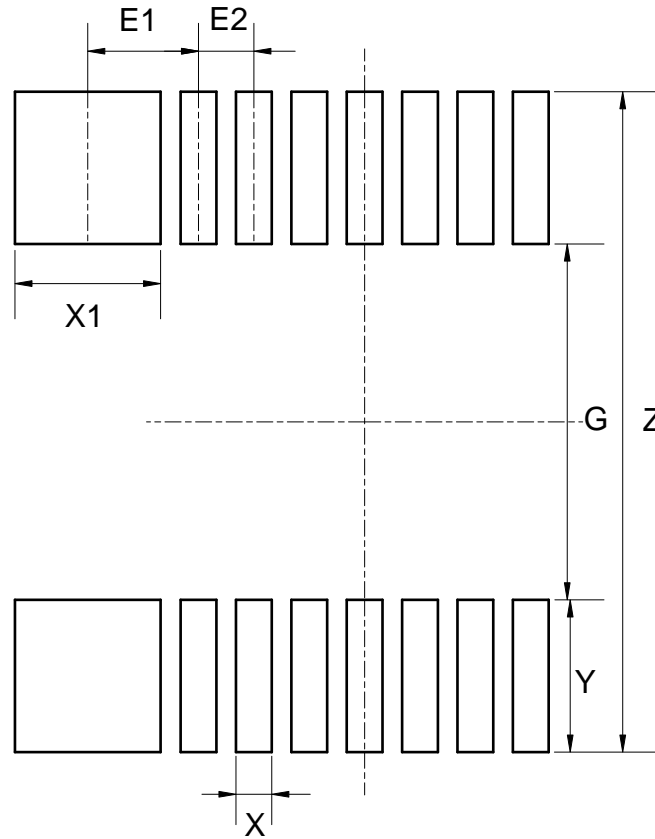

Dimensions	Z (mm)/(inch)	G (mm)/(inch)	X (mm)/(inch)	X1 (mm)/(inch)
Value	7.720/0.304	4.160/0.164	0.420/0.017	1.710/0.067
Dimensions	Y (mm)/(inch)	E1 (mm)/(inch)	E2 (mm)/(inch)	-
Value	1.780/0.070	1.300/0.051	0.650/0.026	-

IMPORTANT NOTICE

DIODES INCORPORATED MAKES NO WARRANTY OF ANY KIND, EXPRESS OR IMPLIED, WITH REGARDS TO THIS DOCUMENT, INCLUDING, BUT NOT LIMITED TO, THE IMPLIED WARRANTIES OF MERCHANTABILITY AND FITNESS FOR A PARTICULAR PURPOSE (AND THEIR EQUIVALENTS UNDER THE LAWS OF ANY JURISDICTION).

Diodes Incorporated and its subsidiaries reserve the right to make modifications, enhancements, improvements, corrections or other changes without further notice to this document and any product described herein. Diodes Incorporated does not assume any liability arising out of the application or use of this document or any product described herein; neither does Diodes Incorporated convey any license under its patent or trademark rights, nor the rights of others. Any Customer or user of this document or products described herein in such applications shall assume all risks of such use and will agree to hold Diodes Incorporated and all the companies whose products are represented on Diodes Incorporated website, harmless against all damages.

Diodes Incorporated does not warrant or accept any liability whatsoever in respect of any products purchased through unauthorized sales channel.

Should Customers purchase or use Diodes Incorporated products for any unintended or unauthorized application, Customers shall indemnify and hold Diodes Incorporated and its representatives harmless against all claims, damages, expenses, and attorney fees arising out of, directly or indirectly, any claim of personal injury or death associated with such unintended or unauthorized application.

Products described herein may be covered by one or more United States, international or foreign patents pending. Product names and markings noted herein may also be covered by one or more United States, international or foreign trademarks.

This document is written in English but may be translated into multiple languages for reference. Only the English version of this document is the final and determinative format released by Diodes Incorporated.

LIFE SUPPORT

Diodes Incorporated products are specifically not authorized for use as critical components in life support devices or systems without the express written approval of the Chief Executive Officer of Diodes Incorporated. As used herein:

A. Life support devices or systems are devices or systems which:

1. are intended to implant into the body, or
2. support or sustain life and whose failure to perform when properly used in accordance with instructions for use provided in the labeling can be reasonably expected to result in significant injury to the user.

B. A critical component is any component in a life support device or system whose failure to perform can be reasonably expected to cause the failure of the life support device or to affect its safety or effectiveness.

Customers represent that they have all necessary expertise in the safety and regulatory ramifications of their life support devices or systems, and acknowledge and agree that they are solely responsible for all legal, regulatory and safety-related requirements concerning their products and any use of Diodes Incorporated products in such safety-critical, life support devices or systems, notwithstanding any devices- or systems-related information or support that may be provided by Diodes Incorporated. Further, Customers must fully indemnify Diodes Incorporated and its representatives against any damages arising out of the use of Diodes Incorporated products in such safety-critical, life support devices or systems.

Copyright © 2013, Diodes Incorporated

www.diodes.com

Компания «Океан Электроники» предлагает заключение долгосрочных отношений при поставках импортных электронных компонентов на взаимовыгодных условиях!

Наши преимущества:

- Поставка оригинальных импортных электронных компонентов напрямую с производств Америки, Европы и Азии, а так же с крупнейших складов мира;
- Широкая линейка поставок активных и пассивных импортных электронных компонентов (более 30 млн. наименований);
- Поставка сложных, дефицитных, либо снятых с производства позиций;
- Оперативные сроки поставки под заказ (от 5 рабочих дней);
- Экспресс доставка в любую точку России;
- Помощь Конструкторского Отдела и консультации квалифицированных инженеров;
- Техническая поддержка проекта, помощь в подборе аналогов, поставка прототипов;
- Поставка электронных компонентов под контролем ВП;
- Система менеджмента качества сертифицирована по Международному стандарту ISO 9001;
- При необходимости вся продукция военного и аэрокосмического назначения проходит испытания и сертификацию в лаборатории (по согласованию с заказчиком);
- Поставка специализированных компонентов военного и аэрокосмического уровня качества (Xilinx, Altera, Analog Devices, Intersil, Interpoint, Microsemi, Actel, Aeroflex, Peregrine, VPT, Syfer, Eurofarad, Texas Instruments, MS Kennedy, Miteq, Cobham, E2V, MA-COM, Hittite, Mini-Circuits, General Dynamics и др.);

Компания «Океан Электроники» является официальным дистрибьютором и эксклюзивным представителем в России одного из крупнейших производителей разъемов военного и аэрокосмического назначения «JONHON», а так же официальным дистрибьютором и эксклюзивным представителем в России производителя высокотехнологичных и надежных решений для передачи СВЧ сигналов «FORSTAR».



JONHON

«JONHON» (основан в 1970 г.)

Разъемы специального, военного и аэрокосмического назначения:

(Применяются в военной, авиационной, аэрокосмической, морской, железнодорожной, горно- и нефтедобывающей отраслях промышленности)

«FORSTAR» (основан в 1998 г.)

ВЧ соединители, коаксиальные кабели, кабельные сборки и микроволновые компоненты:

(Применяются в телекоммуникациях гражданского и специального назначения, в средствах связи, РЛС, а так же военной, авиационной и аэрокосмической отраслях промышленности).



Телефон: 8 (812) 309-75-97 (многоканальный)

Факс: 8 (812) 320-03-32

Электронная почта: ocean@oceanchips.ru

Web: <http://oceanchips.ru/>

Адрес: 198099, г. Санкт-Петербург, ул. Калинина, д. 2, корп. 4, лит. А