

# CAP1114

## Multiple Channel Capacitive Touch Sensor and LED Driver



### PRODUCT FEATURES

Datasheet

#### General Description

The CAP1114, which incorporates SMSC's RightTouch™<sup>1</sup> technology, is a multiple channel Capacitive Touch sensor and LED Driver.

The CAP1114 contains up to fourteen (14) individual Capacitive Touch sensor inputs with programmable sensitivity for use in touch button and slider switch applications. Each sensor also contains automatic recalibration with programmable time delays.

The CAP1114 also includes internal circuitry to compensate for design and parasitic variance in untouched capacitance on sensors.

The CAP1114 also contains eleven (11) low side LED drivers that offer full-on / off, variable rate blinking, dimness controls, and breathing. Capacitive buttons can be linked to LED outputs.

#### Applications

- Consumer Electronics
- Desktop and Notebook PCs
- LCD Monitors

#### Features

- Fourteen (14) capacitive touch sensor inputs
  - Compensates for variable sensor capacitance
  - Programmable sensitivity
  - High SNR allows for easy tuning
  - Automatic recalibration
  - Slider acceleration detection
  - Slider positional detection
  - Proximity detection
- Lid closure detection
- Low power operation
  - 4.5µA quiescent current in Deep Sleep
  - 200µA quiescent current in Sleep while monitoring 1 button
- Alert to signal touch to host processor
- User controlled reset
- Low external component count
- SMBus 2.0 compliant interface to change operating parameters to work in a wide variety of systems
  - Block Read and Write function for quick tasking
- Eleven (11) LED driver outputs
  - Programmable blink, breathe, and dimness controls
  - 8 configurable as GPIOs
  - Buttons can be linked to LED responses
- Development boards and software available
- Available in 32-pin 5mm x 5mm QFN Lead-free RoHS Compliant package

1. SMSC and the SMSC logo are registered trademarks and SMSC RightTouch and the RightTouch logo are trademarks of Standard Microsystems Corporation ("SMSC").

#### Block Diagram

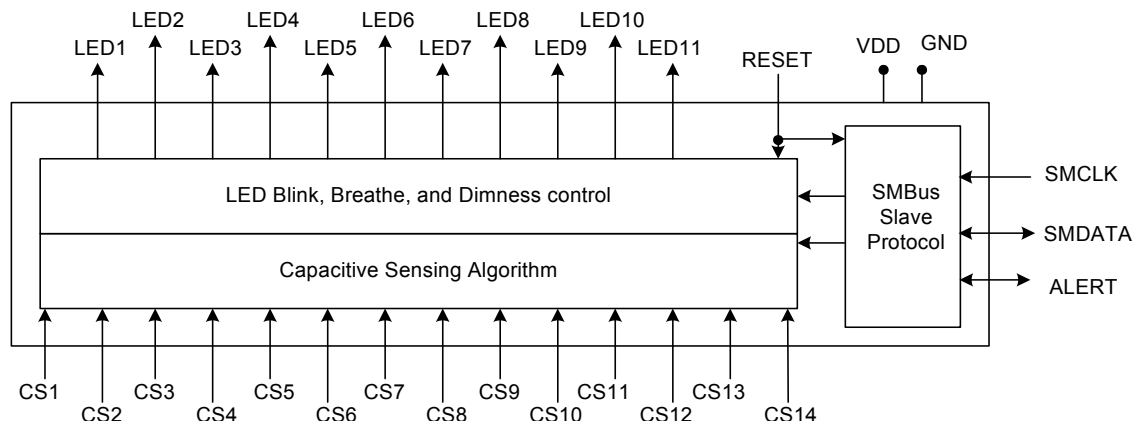

Datasheet

**ORDER NUMBER(S):**

| <b>ORDERING NUMBER</b> | <b>PACKAGE</b>                                     | <b>FEATURES</b>  |
|------------------------|--|--|
| CAP1114-1-EZK-TR       | 32-pin QFN 5mm x 5mm<br>(Lead Free RoHS compliant) | Fourteen Capacitive Touch Sensors.<br>Eleven LED drivers. SMBus<br>communications. |

**REEL SIZE IS 4,000 PIECES**

**This product meets the halogen maximum concentration values per IEC61249-2-21**

**For RoHS compliance and environmental information, please visit [www.smssc.com/rohs](http://www.smssc.com/rohs)**

*Please contact your SMSC sales representative for additional documentation related to this product such as application notes, anomaly sheets, and design guidelines.*

Copyright © 2010 SMSC or its subsidiaries. All rights reserved.

Circuit diagrams and other information relating to SMSC products are included as a means of illustrating typical applications. Consequently, complete information sufficient for construction purposes is not necessarily given. Although the information has been checked and is believed to be accurate, no responsibility is assumed for inaccuracies. SMSC reserves the right to make changes to specifications and product descriptions at any time without notice. Contact your local SMSC sales office to obtain the latest specifications before placing your product order. The provision of this information does not convey to the purchaser of the described semiconductor devices any licenses under any patent rights or other intellectual property rights of SMSC or others. All sales are expressly conditional on your agreement to the terms and conditions of the most recently dated version of SMSC's standard Terms of Sale Agreement dated before the date of your order (the "Terms of Sale Agreement"). The product may contain design defects or errors known as anomalies which may cause the product's functions to deviate from published specifications. Anomaly sheets are available upon request. SMSC products are not designed, intended, authorized or warranted for use in any life support or other application where product failure could cause or contribute to personal injury or severe property damage. Any and all such uses without prior written approval of an Officer of SMSC and further testing and/or modification will be fully at the risk of the customer. Copies of this document or other SMSC literature, as well as the Terms of Sale Agreement, may be obtained by visiting SMSC's website at <http://www.smssc.com>. SMSC is a registered trademark of Standard Microsystems Corporation ("SMSC"). Product names and company names are the trademarks of their respective holders.

The Microchip name and logo, and the Microchip logo are registered trademarks of Microchip Technology Incorporated in the U.S.A. and other countries.

**SMSC DISCLAIMS AND EXCLUDES ANY AND ALL WARRANTIES, INCLUDING WITHOUT LIMITATION ANY AND ALL IMPLIED WARRANTIES OF MERCHANTABILITY, FITNESS FOR A PARTICULAR PURPOSE, TITLE, AND AGAINST INFRINGEMENT AND THE LIKE, AND ANY AND ALL WARRANTIES ARISING FROM ANY COURSE OF DEALING OR USAGE OF TRADE. IN NO EVENT SHALL SMSC BE LIABLE FOR ANY DIRECT, INCIDENTAL, INDIRECT, SPECIAL, PUNITIVE, OR CONSEQUENTIAL DAMAGES; OR FOR LOST DATA, PROFITS, SAVINGS OR REVENUES OF ANY KIND; REGARDLESS OF THE FORM OF ACTION, WHETHER BASED ON CONTRACT; TORT; NEGLIGENCE OF SMSC OR OTHERS; STRICT LIABILITY; BREACH OF WARRANTY; OR OTHERWISE; WHETHER OR NOT ANY REMEDY OF BUYER IS HELD TO HAVE FAILED OF ITS ESSENTIAL PURPOSE, AND WHETHER OR NOT SMSC HAS BEEN ADVISED OF THE POSSIBILITY OF SUCH DAMAGES.**

## Table of Contents

|                  |   |           |
|------------------|---|-----------|
| <b>Chapter 1</b> | <b>Delta from CAP1014 to CAP1114</b>              | <b>9</b>  |
| 1.1              | Summary   | 9         |
| 1.2              | Register Delta                                    | 10        |
| <b>Chapter 2</b> | <b>Pin Description</b>                            | <b>12</b> |
| <b>Chapter 3</b> | <b>Electrical Specifications</b>                  | <b>15</b> |
| <b>Chapter 4</b> | <b>Communications</b>                             | <b>18</b> |
| 4.1              | System Management Bus Protocol                    | 18        |
| 4.1.1            | SMBus Start Bit                                   | 18        |
| 4.1.2            | SMBus Address and RD / $\overline{\text{WR}}$ Bit | 18        |
| 4.1.3            | SMBus Data Bytes                                  | 18        |
| 4.1.4            | SMBus ACK and NACK Bits                           | 18        |
| 4.1.5            | SMBus Stop Bit                                    | 19        |
| 4.1.6            | SMBus Time-out                                    | 19        |
| 4.1.7            | SMBus and I <sup>2</sup> C Compliance             | 19        |
| 4.2              | SMBus Protocols                                   | 19        |
| 4.2.1            | SMBus Write Byte                                  | 19        |
| 4.2.2            | Block Write                                       | 20        |
| 4.2.3            | SMBus Read Byte                                   | 20        |
| 4.2.4            | Block Read  | 20        |
| 4.2.5            | SMBus Send Byte                                   | 20        |
| 4.2.6            | SMBus Receive Byte                                | 21        |
| <b>Chapter 5</b> | <b>Product Description</b>                        | <b>22</b> |
| 5.1              | Power States                                      | 23        |
| 5.2              | RESET Pin   | 25        |
| 5.3              | LED Drivers                                       | 25        |
| 5.3.1            | Linking LEDs to Capacitive Touch Sensors          | 25        |
| 5.4              | Capacitive Touch Sensing                          | 25        |
| 5.4.1            | Multiple Button Presses                           | 26        |
| 5.4.2            | Lid Closure                                       | 26        |
| 5.4.3            | Grouped Sensors (CS8 - CS14)                      | 26        |
| 5.4.4            | Sensing Cycle                                     | 26        |
| 5.4.5            | Proximity Detection                               | 26        |
| 5.4.6            | Recalibrating Sensors                             | 26        |
| 5.4.7            | Low Frequency Noise Detection                     | 26        |
| 5.4.8            | RF Noise Detection                                | 27        |
| 5.5              | Grouped Sensor Behavior                           | 27        |
| 5.5.1            | Tap   | 27        |
| 5.5.2            | Press and Hold                                    | 27        |
| 5.5.3            | Slider  | 27        |
| 5.5.4            | Relative Position                                 | 28        |
| 5.5.5            | Slider Velocity                                   | 28        |
| 5.6              | Ungrouped Sensor Behavior                         | 28        |
| 5.6.1            | CS9 - CS13 Ungrouped Behavior                     | 28        |
| 5.6.2            | CS8 and CS14 Ungrouped Behavior                   | 28        |
| 5.7              | ALERT Pin   | 28        |
| 5.7.1            | Button Interrupt Behavior                         | 29        |
| 5.7.2            | Grouped Sensor Interrupt Behavior                 | 29        |

## Datasheet

|                  |  |           |
|------------------|--|-----------|
| 5.7.3            | Wake from Deep Sleep                       | 29        |
| <hr/>            |  |           |
| <b>Chapter 6</b> | <b>Register Description</b>                | <b>34</b> |
| 6.1              | Main Status Control Register               | 41        |
| 6.2              | Button Status Registers                    | 42        |
| 6.2.1            | Button Status 1                            | 42        |
| 6.2.2            | Button Status 2                            | 43        |
| 6.3              | Build Revision Register                    | 43        |
| 6.4              | Slider Position / Volumetric Data Register | 43        |
| 6.4.1            | Absolute Position                          | 44        |
| 6.4.2            | Volumetric Data                            | 44        |
| 6.5              | Vendor ID Register                         | 45        |
| 6.6              | Volumetric Step Register                   | 45        |
| 6.7              | Noise Status Registers                     | 45        |
| 6.8              | Lid Closure Status Registers               | 46        |
| 6.9              | GPIO Status Register                       | 46        |
| 6.10             | Group Status Register                      | 47        |
| 6.11             | Sensor Delta Count Registers               | 47        |
| 6.12             | Queue Control Register                     | 48        |
| 6.13             | Data Sensitivity Registers                 | 49        |
| 6.14             | Configuration Register                     | 51        |
| 6.15             | Sensor Enable Register                     | 52        |
| 6.16             | Button Configuration Register              | 53        |
| 6.17             | Group Configuration Register 1             | 54        |
| 6.18             | Group Configuration Register 2             | 55        |
| 6.19             | Calibration Enable Register                | 56        |
| 6.20             | Calibration Activate Registers             | 56        |
| 6.20.1           | Calibration Activate - 26h                 | 57        |
| 6.20.2           | Grouped Sensor Calibration Activate - 46h  | 57        |
| 6.21             | Interrupt Enable Registers                 | 58        |
| 6.21.1           | Interrupt Enable 1                         | 58        |
| 6.21.2           | Interrupt Enable 2                         | 58        |
| 6.22             | Sleep Channel Control Register             | 59        |
| 6.23             | Multiple Touch Configuration Register      | 60        |
| 6.24             | Lid Closure Configuration Register         | 61        |
| 6.25             | Lid Closure Queue Control Register         | 61        |
| 6.26             | Lid Closure Pattern Registers              | 62        |
| 6.27             | Recalibration Configuration Register       | 63        |
| 6.28             | Sensor Threshold Registers                 | 64        |
| 6.29             | Button Noise Threshold Registers           | 65        |
| 6.29.1           | Button Noise Threshold 1 Register          | 65        |
| 6.29.2           | Button Noise Threshold 2 Register          | 66        |
| 6.30             | Lid Closure Threshold Registers            | 66        |
| 6.30.1           | Lid Closure Threshold 1 Register           | 66        |
| 6.30.2           | Lid Closure Threshold 2 Register           | 67        |
| 6.30.3           | Lid Closure Threshold 3 Register           | 67        |
| 6.30.4           | Lid Closure Threshold 4 Register           | 67        |
| 6.31             | Slider Velocity Configuration Register     | 67        |
| 6.32             | Digital Recalibration Control Register     | 69        |
| 6.33             | Configuration 2 Register                   | 70        |
| 6.34             | Grouped Sensor Channel Enable Register     | 71        |
| 6.35             | Proximity Control Register                 | 72        |
| 6.36             | Sampling Channel Select Register           | 73        |
| 6.37             | Sampling Configuration Register            | 73        |
| 6.38             | Sensor Base Count Registers                | 74        |

|   |  |            |
|---|--|------------|
| 6.39  | LED Status Registers                       | 75         |
| 6.39.1                                      | LED Status 1                               | 75         |
| 6.39.2                                      | LED Status 2                               | 76         |
| 6.40  | LED / GPIO Direction Register              | 76         |
| 6.41  | LED / GPIO Output Type Register            | 77         |
| 6.42  | GPIO Input Register                        | 77         |
| 6.43  | LED Output Control Registers               | 78         |
| 6.43.1                                      | LED Output Control 1                       | 78         |
| 6.43.2                                      | LED Output Control 2                       | 78         |
| 6.44  | LED Polarity Registers                     | 79         |
| 6.44.1                                      | LED Polarity 1                             | 80         |
| 6.44.2                                      | LED Polarity 2                             | 80         |
| 6.45  | Linked LED Transition Control Registers    | 81         |
| 6.45.1                                      | Linked LED Transition Control 1 - 77h      | 81         |
| 6.45.2                                      | Linked LED Transition Control 2 - 78h      | 81         |
| 6.46  | LED Mirror Control                         | 82         |
| 6.46.1                                      | LED Mirror Control 1 - 79h                 | 82         |
| 6.46.2                                      | LED Mirror Control 2 - 7Ah                 | 83         |
| 6.47  | Sensor LED Linking Register                | 83         |
| 6.48  | LED Behavior Registers                     | 84         |
| 6.48.1                                      | LED Behavior 1 - 81h                       | 84         |
| 6.48.2                                      | LED Behavior 2 - 82h                       | 85         |
| 6.48.3                                      | LED Behavior 3 - 83h                       | 85         |
| 6.49  | LED Pulse 1 Period Register                | 86         |
| 6.50  | LED Pulse 2 Period Register                | 88         |
| 6.51  | LED Breathe Period Register                | 89         |
| 6.52  | LED Configuration Register                 | 89         |
| 6.53  | LED Pulse and Breathe Duty Cycle Registers | 90         |
| 6.54  | LED Direct Ramp Rates Register             | 91         |
| 6.55  | LED Off Delay Register                     | 92         |
| 6.56  | Sensor Calibration Registers               | 94         |
| 6.57  | Product ID Register                        | 95         |
| 6.58  | Revision Register                          | 95         |
| <hr/>                                       |  |            |
| <b>Chapter 7 Package Information</b>        |  | <b>96</b>  |
| 7.1   | Package Drawings                           | 96         |
| 7.2   | Package Marking                            | 100        |
| <hr/>                                       |  |            |
| <b>Chapter 8 Datasheet Revision History</b> |  | <b>101</b> |

## Datasheet

## List of Figures

|            |   |     |
|------------|---|-----|
| Figure 2.1 | CAP1114 Pin Diagram (32-Pin QFN)                              | 12  |
| Figure 4.1 | SMBus Timing Diagram  | 18  |
| Figure 5.1 | System Diagram for CAP1114                                    | 23  |
| Figure 5.2 | Button Interrupt Behavior - Repeat Rate Enabled (default)     | 29  |
| Figure 5.3 | Button Interrupt Behavior - No Repeat Rate Enabled            | 30  |
| Figure 5.4 | Tap Interrupt Behavior  | 30  |
| Figure 5.5 | Press and Hold Interrupt Behavior                             | 31  |
| Figure 5.6 | Slide Interrupt Behavior - No Acceleration                    | 32  |
| Figure 5.7 | Slide Interrupt Behavior - Acceleration Example               | 33  |
| Figure 6.1 | Pulse 1 Behavior with Touch Trigger and Non-inverted Polarity | 87  |
| Figure 6.2 | Pulse 1 Behavior with Touch Trigger and Inverted Polarity     | 87  |
| Figure 6.3 | Pulse 2 Behavior with Non-Inverted Polarity                   | 88  |
| Figure 6.4 | Pulse 2 Behavior with Inverted Polarity                       | 89  |
| Figure 6.5 | Direct Behavior for Non-Inverted Polarity                     | 93  |
| Figure 6.6 | Direct Behavior for Inverted Polarity                         | 93  |
| Figure 7.1 | Package Diagram - 32-Pin QFN                                  | 96  |
| Figure 7.2 | Package Dimensions - 32-Pin QFN                               | 97  |
| Figure 7.3 | Package PCB Land Pattern and Stencil                          | 98  |
| Figure 7.4 | Package Detail A - Stencil Opening and Perimeter Lands        | 98  |
| Figure 7.5 | Package Detail B - Thermal Vias and Stencil Opening           | 99  |
| Figure 7.6 | Package Land Pattern Dimensions                               | 99  |
| Figure 7.7 | Package Markings  | 100 |

## List of Tables

|            |  |    |
|------------|--|----|
| Table 1.1  | Register Delta                             | 10 |
| Table 2.1  | Pin Description for CAP1114                | 12 |
| Table 2.2  | Pin Types                                  | 14 |
| Table 3.1  | Absolute Maximum Ratings                   | 15 |
| Table 3.2  | Electrical Specifications                  | 15 |
| Table 4.1  | Protocol Format                            | 19 |
| Table 4.2  | Write Byte Protocol                        | 19 |
| Table 4.3  | Block Write Protocol                       | 20 |
| Table 4.4  | Read Byte Protocol                         | 20 |
| Table 4.5  | Block Read Protocol                        | 20 |
| Table 4.6  | Send Byte Protocol                         | 21 |
| Table 4.7  | Receive Byte Protocol                      | 21 |
| Table 5.1  | Power States                               | 24 |
| Table 6.1  | Register Set in Hexadecimal Order          | 34 |
| Table 6.2  | Main Status Control Register               | 41 |
| Table 6.3  | Button Status Registers                    | 42 |
| Table 6.4  | Build Revision Register                    | 43 |
| Table 6.5  | Slider Position / Volumetric Data Register | 43 |
| Table 6.6  | Example Slider Absolute Position Decode    | 44 |
| Table 6.7  | Vendor ID Register                         | 45 |
| Table 6.8  | Volumetric Step Register                   | 45 |
| Table 6.9  | Noise Status Registers                     | 45 |
| Table 6.10 | Lid Closure Status Registers               | 46 |
| Table 6.11 | GPIO Status Register                       | 46 |
| Table 6.12 | Group Status Register                      | 47 |
| Table 6.13 | Sensor Delta Count Registers               | 47 |
| Table 6.14 | Queue Control Register                     | 48 |
| Table 6.15 | QUEUE_B Bit Decode                         | 49 |
| Table 6.16 | Data Sensitivity Register                  | 49 |
| Table 6.17 | DELTA_SENSE Bit Decode                     | 50 |
| Table 6.18 | BASE_SHIFT Bit Decode                      | 50 |
| Table 6.19 | Configuration Register                     | 51 |
| Table 6.20 | Sensor Enable Register                     | 52 |
| Table 6.21 | Button Configuration Register              | 53 |
| Table 6.22 | MAX_DUR_B and MAX_DUR_G Bit Decode         | 53 |
| Table 6.23 | RPT_RATE_B / SL / PH Bit Decode            | 54 |
| Table 6.24 | Group Configuration Register 1             | 54 |
| Table 6.25 | M_PRESS Bit Decode                         | 55 |
| Table 6.26 | Group Configuration Register 2             | 55 |
| Table 6.27 | Calibration Enable Register                | 56 |
| Table 6.28 | Calibration Activate Registers             | 56 |
| Table 6.29 | Interrupt Enable Registers                 | 58 |
| Table 6.30 | Sleep Channel Control Register             | 59 |
| Table 6.31 | Multiple Touch Configuration Register      | 60 |
| Table 6.32 | B_MULT_T Bit Decode                        | 60 |
| Table 6.33 | G_MULT_T Bit Decode                        | 60 |
| Table 6.34 | Lid Closure Configuration Register         | 61 |
| Table 6.35 | Lid Closure Queue Control Register         | 61 |
| Table 6.36 | Lid Closure Pattern Registers              | 62 |
| Table 6.37 | Recalibration Configuration Register       | 63 |
| Table 6.38 | NEG_DELTA_CNT Bit Decode                   | 63 |
| Table 6.39 | CAL_CFG Bit Decode                         | 64 |
| Table 6.40 | Sensor Threshold Registers                 | 64 |

**Datasheet**

|  |     |
|--|-----|
| Table 6.41 Button Noise Threshold Registers . . . . .            | 65  |
| Table 6.42 CSx_BN_TH Bit Decode . . . . .                        | 65  |
| Table 6.43 Lid Closure Threshold Registers . . . . .             | 66  |
| Table 6.44 CSx_LD_TH Bit Decode . . . . .                        | 66  |
| Table 6.45 Slider Velocity Configuration Register . . . . .      | 67  |
| Table 6.46 MAX_INT Bit Decode. . . . .                           | 68  |
| Table 6.47 SLIDE_TIME Bit Decode . . . . .                       | 68  |
| Table 6.48 RPT_SCALE Bit Decode . . . . .                        | 69  |
| Table 6.49 Digital Recalibration Control Register . . . . .      | 69  |
| Table 6.50 Configuration 2 Register . . . . .                    | 70  |
| Table 6.51 Grouped Sensor Channel Enable Register . . . . .      | 71  |
| Table 6.52 Proximity Control Register . . . . .                  | 72  |
| Table 6.53 PROX_AVG Bit Decode . . . . .                         | 72  |
| Table 6.54 Sampling Channel Select Register . . . . .            | 73  |
| Table 6.55 Sampling Configuration Register . . . . .             | 73  |
| Table 6.56 OVERSAMP_RATE Bit Decode . . . . .                    | 74  |
| Table 6.57 Sensor Base Count Registers . . . . .                 | 74  |
| Table 6.58 LED Status Registers . . . . .                        | 75  |
| Table 6.59 LED / GPIO Direction Register . . . . .               | 76  |
| Table 6.60 LED / GPIO Output Type Register. . . . .              | 77  |
| Table 6.61 GPIO Input Register . . . . .                         | 77  |
| Table 6.62 LED Output Control Registers . . . . .                | 78  |
| Table 6.63 LED Polarity Registers. . . . .                       | 79  |
| Table 6.64 LED Polarity Behavior . . . . .                       | 80  |
| Table 6.65 Linked LED Transition Control Registers. . . . .      | 81  |
| Table 6.66 LED Mirror Control Registers. . . . .                 | 82  |
| Table 6.67 Sensor LED Linking Register. . . . .                  | 83  |
| Table 6.68 LED Behavior Registers . . . . .                      | 84  |
| Table 6.69 LEDx_CTL Bit Decode. . . . .                          | 85  |
| Table 6.70 LED Pulse 1 Period Register . . . . .                 | 86  |
| Table 6.71 LED Pulse / Breathe Period Example . . . . .          | 87  |
| Table 6.72 LED Pulse 2 Period Register . . . . .                 | 88  |
| Table 6.73 LED Breathe Period Register . . . . .                 | 89  |
| Table 6.74 LED Configuration Registers . . . . .                 | 89  |
| Table 6.75 PULSE_CNT Decode . . . . .                            | 90  |
| Table 6.76 LED Period and Breathe Duty Cycle Registers . . . . . | 90  |
| Table 6.77 LED Duty Cycle Decode . . . . .                       | 91  |
| Table 6.78 LED Direct Ramp Rates Register . . . . .              | 91  |
| Table 6.79 Rise / Fall Rate Cycle Decode. . . . .                | 92  |
| Table 6.80 LED Off Delay Register . . . . .                      | 92  |
| Table 6.81 Off Delay Settings . . . . .                          | 92  |
| Table 6.82 Sensor Calibration Registers . . . . .                | 94  |
| Table 6.83 Product ID Register . . . . .                         | 95  |
| Table 6.84 Revision Register. . . . .                            | 95  |
| Table 8.1 Customer Revision History . . . . .                    | 101 |



# Chapter 1 Delta from CAP1014 to CAP1114

## 1.1 Summary

1. Updated circuitry to reduce sensitivity to power supply stepping.
2. Updated LED Pulse 1 behavior. This function may be triggered on button press or on release. See [Section 6.49](#).
3. Updated Product ID to 3Ah.
4. Updated LED behavior for host control during direct mode when not linked. The LED Output register will now be able to be written to emulate a touch or release. Enables all behaviors while in host mode. See [Section 6.43](#) and [Section 6.44](#).
5. Updated recalibration controls to add negative delta count. See [Section 6.27](#).
6. Removed ACAL\_RT bits.
7. Added digital controls to disable the slider functionality but still detect basic touches essentially bypassing the slider algorithms entirely. See [Section 6.33](#).
8. Added controls to enable individual buttons in the slider. See [Section 6.34](#).
9. Updated button interrupt schemes to allow interrupt on press only, not on release. Retained previous behavior as default. See [Figure 5.2](#), [Figure 5.3](#), and [Section 5.7.1](#). Retained previous behavior as default. See [Section 6.27](#).
10. Updated Noise Threshold default settings to ~25%. See [Section 6.29](#).
11. Added control bit and status registers to enable interrupt when LEDs finish their directed behavior in the same fashion. See [Section 6.52](#) and [Section 6.39](#).
12. Updated LED driver duty cycle decode values to have more distribution at lower values - closer to a logarithmic curve. See [Section 6.53](#).
13. Renamed D\_DSP[3:0] and C\_DSP[3:0] to DELTA\_SENSE[2:0] and BASE\_SHIFT[3:0]. D\_DSP[3] did nothing so removed references. See [Section 6.13](#).
14. Added filtering on RESET pin to prevent errant resets. The RESET pin must be high or low for longer than 10ms before it will be detected by the device. See [Section 8.6](#).
15. Added proximity to CS1 channel.
16. Updated Deep Sleep to wake on communications. See [Section 5.1](#).
17. Updated controls so that the RESET pin assertion places the device into the lowest power state available. See [Section 5.2](#) and [Section 5.1](#).
18. Added LED transition controls that affect the LED behavior when a Capacitive Touch Sensor is linked to an LED channel to remove bouncing. See [Section 6.45](#).
19. Added controls to “mirror” the LED duty cycle outputs so that when polarity changed, the LED brightness levels look right. See [Section 6.46](#).
20. Added register to force digital recalibration of all sensors. See [Section 6.32](#).
21. Added register to enable oversampling on specific sensors. See [Section 6.35](#) and [Section 6.37](#).
22. Changed PWM frequency for LED drivers. The PWM frequency was derived from the programmed breathe period and duty cycle settings and it ranged from ~4Hz to ~8000 Hz. The PWM frequency has been updated to be a fixed value of ~2000Hz.

## 1.2 Register Delta

Table 1.1 Register Delta

| ADDRESS | REGISTER DELTA                          | DELTA  | DEFAULT |
|---------|---|--|---------|
| 05h     | Changed - Build Revision                | Reset build revision to 10h  | 10h     |
| 20h     | Changed - Configuration                 | Changed functionality of RPT_EN_B bit.<br>Changed default  | 29h     |
| 2Fh     | Changed - Recalibration Configuration   | Removed ACAL_RT[1:0] bits and replaced with NEG_CNT[1:0] bits. These bits control recalibration when negative counts are received. | 93h     |
| 38h     | Changed - Button Noise Threshold 1      | Changed default  | AAh     |
| 39h     | Changed - Button Noise Threshold 2      | Changed default  | AAh     |
| 3Fh     | New - Digital Recalibration             | New register to force digital recalibration on all sensors   | 00h     |
| 40h     | New - Configuration 2                   | New register to control LED touch linking behavior, LED output behavior, and noise detection, and interrupt on release             | 00h     |
| 41h     | New - Grouped Channel Sensor Enable     | New register to enable individual sensors within the grouped sensors   | 7Fh     |
| 42h     | New - Proximity Control                 | New register to enable / configure proximity settings on CS1   | 02h     |
| 46h     | New - Group Button Calibration Activate | New register to force calibration on individual grouped sensors  | 00h     |
| 4Eh     | New - Sampling Channel Select           | New register to select which channels can be controlled via the Sampling Configuration register                                    | 00h     |
| 60h     | New - LED Status 1                      | New register to store status for LEDs that have finished their programmed behavior   | 00h     |
| 61h     | New - LED Status 2                      | New register to store status for LEDs that have finished their programmed behavior   | 00h     |
| 77h     | New - Linked LED Transition Control 1   | New register to control transition effect when LED linked to CS sensor   | 00h     |
| 78h     | New - Linked LED Transition Control 2   | New register to control transition effect when LED linked to CS sensor   | 00h     |
| 79h     | New - LED Mirror Control 1              | New register to control LED output mirroring for brightness control when polarity changed  | 00h     |
| 7Ah     | New - LED Mirror Control 2              | New register to control LED output mirroring for brightness control when polarity changed  | 00h     |

Table 1.1 Register Delta (continued)

| ADDRESS | REGISTER DELTA                   | DELTA                                       | DEFAULT |
|---------|----------------------------------|---|---------|
| 90h     | Changed - LED Pulse 1 Duty Cycle | Changed bit decode to be more logarithmic   | F0h     |
| 91h     | Changed - LED Pulse 2 Duty Cycle | Changed bit decode to be more logarithmic   | F0h     |
| 92h     | Changed - LED Breathe Duty Cycle | Changed bit decode to be more logarithmic   | F0h     |
| 93h     | Changed - LED Direct Duty Cycle  | Changed bit decode to be more logarithmic   | F0h     |
| FDh     | Changed - Product ID             | Changed bit decode for CAP1114              | 3Ah     |
| FEh     | Added - Manufacturer ID          | Added - this register mirrors the Vendor ID | 5Dh     |

## Chapter 2 Pin Description

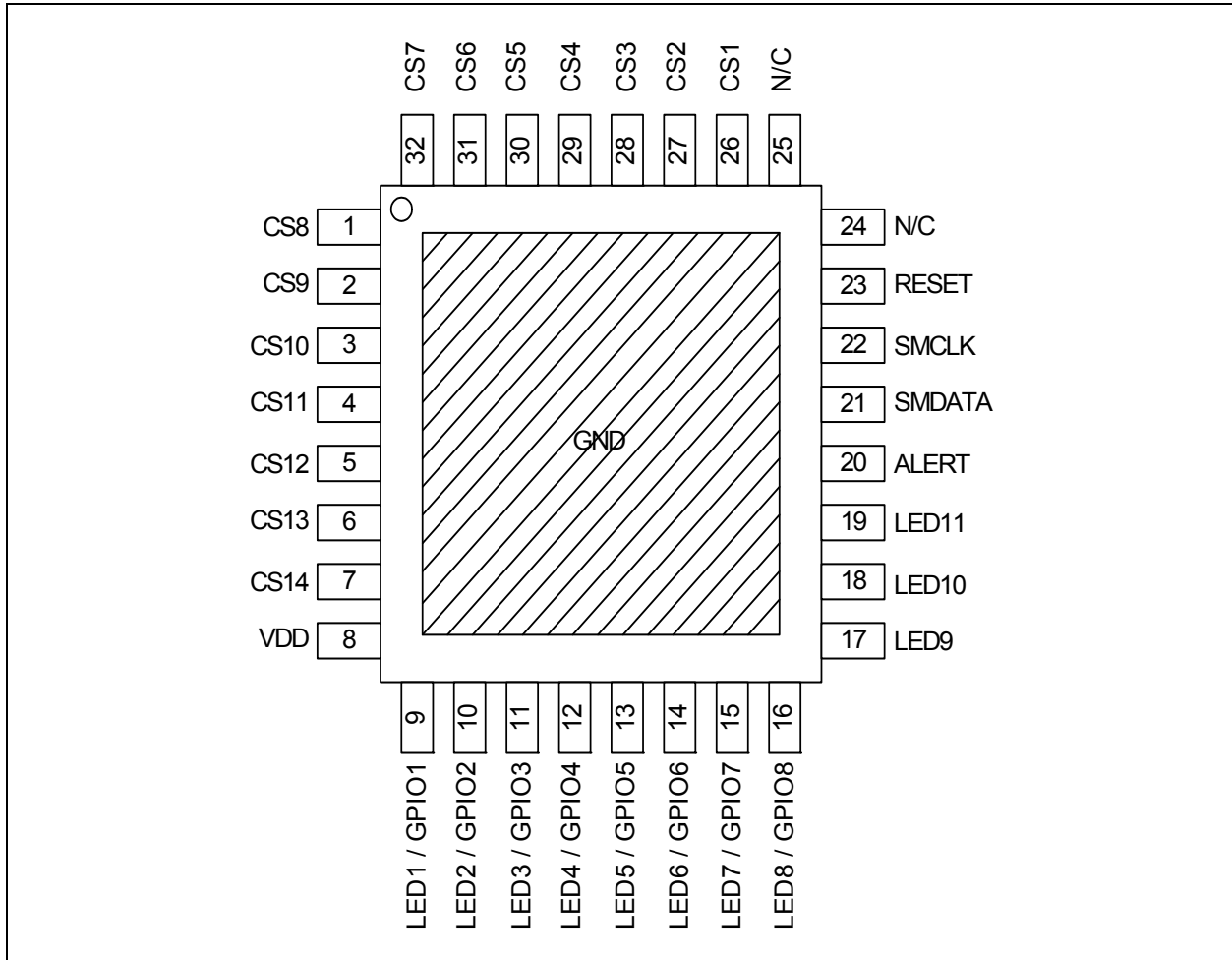

Figure 2.1 CAP1114 Pin Diagram (32-Pin QFN)

Table 2.1 Pin Description for CAP1114

| PIN NUMBER | PIN NAME | PIN FUNCTION               | PIN TYPE |
|------------|----------|----------------------------|----------|
| 1          | CS8      | Capacitive Touch Sensor 8  | AIO      |
| 2          | CS9      | Capacitive Touch Sensor 9  | AIO      |
| 3          | CS10     | Capacitive Touch Sensor 10 | AIO      |
| 4          | CS11     | Capacitive Touch Sensor 11 | AIO      |
| 5          | CS12     | Capacitive Touch Sensor 12 | AIO      |
| 6          | CS13     | Capacitive Touch Sensor 13 | AIO      |
| 7          | CS14     | Capacitive Touch Sensor 14 | AIO      |

Table 2.1 Pin Description for CAP1114 (continued)

| PIN NUMBER | PIN NAME      | PIN FUNCTION   | PIN TYPE  |
|------------|---------------|--|-----------|
| 8          | VDD           | Positive Power supply  | Power     |
| 9          | LED1 / GPIO1  | LED1 - Open drain LED driver (default)                         | OD (5V)   |
|            |               | GPI1 - GPIO 1 Input  | DI (5V)   |
|            |               | GPO1 - GPIO 1 push-pull output                                 | DO        |
| 10         | LED2 / GPIO 2 | LED2 - Open drain LED driver (default)                         | OD (5V)   |
|            |               | GPI2 - GPIO 2 Input  | DI (5V)   |
|            |               | GPO2 - GPIO 2 push-pull output                                 | DO        |
| 11         | LED3 / GPIO3  | LED3 - Open drain LED driver (default)                         | OD (5V)   |
|            |               | GPI3 - GPIO 3 Input  | DI (5V)   |
|            |               | GPO3 - GPIO 3 push-pull output                                 | DO        |
| 12         | LED4 / GPIO4  | LED4 - Open drain LED driver (default)                         | OD (5V)   |
|            |               | GPI4 - GPIO 4 Input  | DI (5V)   |
|            |               | GPO4 - GPIO 4 push-pull output                                 | DO        |
| 13         | LED5 / GPIO5  | LED5 - Open drain LED driver (default)                         | OD (5V)   |
|            |               | GPI5 - GPIO 5 Input  | DI (5V)   |
|            |               | GPO5 - GPIO 5 push-pull output                                 | DO        |
| 14         | LED6 / GPIO6  | LED6 - Open drain LED driver (default)                         | OD (5V)   |
|            |               | GPI6 - GPIO 6 Input  | DI (5V)   |
|            |               | GPO6 - GPIO 6 push-pull output                                 | DO        |
| 15         | LED7 / GPIO7  | LED7 - Open drain LED driver (default)                         | OD (5V)   |
|            |               | GPI7 - GPIO 7 Input  | DI (5V)   |
|            |               | GPO7 - GPIO 7 push-pull output                                 | DO        |
| 16         | LED8 / GPIO8  | LED8 - Open drain LED driver (default)                         | OD (5V)   |
|            |               | GPI8 - GPIO 8 Input  | DI (5V)   |
|            |               | GPO8 - GPIO 8 push-pull output                                 | DO        |
| 17         | LED9          | LED9 - Open drain LED driver                                   | OD (5V)   |
| 18         | LED10         | LED10 - Open drain LED driver                                  | OD (5V)   |
| 19         | LED11         | LED11 - Open drain LED driver                                  | OD (5V)   |
| 20         | ALERT         | Active High Interrupt / Wake Up Input                          | DIO       |
| 21         | SMDATA        | Bi-directional SMBus data - requires a pull-up resistor        | DIOD (5V) |
| 22         | SMCLK         | SMBus clock input - requires a pull-up resistor                | DI (5V)   |
| 23         | RESET         | Soft reset for system - resets all registers to default values | DI (5V)   |

## Datasheet

Table 2.1 Pin Description for CAP1114 (continued)

| PIN NUMBER   | PIN NAME | PIN FUNCTION                   | PIN TYPE |
|--------------|----------|--------------------------------|----------|
| 24           | N/C      | Not Connected - connect to gnd | N/A      |
| 25           | N/C      | Not Connected - connect to gnd | N/A      |
| 26           | CS1      | Capacitive Touch Sensor 1      | AIO      |
| 27           | CS2      | Capacitive Touch Sensor 2      | AIO      |
| 28           | CS3      | Capacitive Touch Sensor 3      | AIO      |
| 29           | CS4      | Capacitive Touch Sensor 4      | AIO      |
| 30           | CS5      | Capacitive Touch Sensor 5      | AIO      |
| 31           | CS6      | Capacitive Touch Sensor 6      | AIO      |
| 32           | CS7      | Capacitive Touch Sensor 7      | AIO      |
| Bottom Plate | GND      | Power Ground                   | Power    |

The pin types are described in [Table 2.2, "Pin Types"](#). All pins labeled with (5V) are 5V tolerant.

**Note:** For all 5V tolerant pins that require a pull-up resistor, the voltage difference between VDD and the pull-up voltage must never exceed 3.6V.

Table 2.2 Pin Types

| PIN TYPE | DESCRIPTION  |
|----------|--|
| Power    | This pin is used to supply power or ground to the device.  |
| DI       | Digital Input - this pin is used as a digital input. This pin is 5V tolerant.  |
| DIO      | Digital Input Output - this pin is used as a digital input / output.   |
| AIO      | Analog Input / Output - this pin is used as an I/O for analog signals.   |
| DIOD     | Digital Input / Open Drain Output - this pin is used as an digital I/O. When it is used as an output, It is open drain and requires a pull-up resistor. This pin is 5V tolerant. |
| OD       | Open Drain Digital Output - this pin is used as a digital output. It is open drain and requires a pull-up resistor. This pin is 5V tolerant.                                     |
| DO       | Push-pull Digital Output - this pin is used as a digital output and can sink and source current.   |

## Chapter 3 Electrical Specifications

**Table 3.1 Absolute Maximum Ratings**

|   |                   |                    |
|---|-------------------|--------------------|
| Voltage on VDD pin  | -0.3 to 4         | V                  |
| Voltage on 5V tolerant pins ( $V_{5VT\_PIN}$ )  | -0.3 to 5.5       | V                  |
| Voltage on 5V tolerant pins ( $(V_{5VT\_PIN} - V_{DD})$ ) (see <a href="#">Note 3.1</a> ) | 0 to 3.6          | V                  |
| Voltage on any other pin to GND   | -0.3 to VDD + 0.3 | V                  |
| Package Power Dissipation up to $T_A = 85^\circ\text{C}$ (see <a href="#">Note 3.2</a> )  | 1                 | W                  |
| Junction to Ambient ( $\theta_{JA}$ ) (see <a href="#">Note 3.3</a> )                     | 48                | $^\circ\text{C/W}$ |
| Operating Ambient Temperature Range   | -40 to 125        | $^\circ\text{C}$   |
| Storage Temperature Range   | -55 to 150        | $^\circ\text{C}$   |
| ESD Rating, All Pins, HBM   | 8000              | V                  |

**Note:** Stresses above those listed could cause permanent damage to the device. This is a stress rating only and functional operation of the device at any other condition above those indicated in the operation sections of this specification is not implied.

**Note 3.1** For the 5V tolerant pins that have a pull-up resistor, the pull-up voltage must not exceed 3.6V when the device is unpowered.

**Note 3.2** The Package Power Dissipation specification assumes a thermal via design with the thermal landing be soldered to the PCB ground plane with 0.3mm (12mil) diameter vias in a 4x4 matrix at 0.9mm (35.4mil) pitch.

**Note 3.3** Junction to Ambient ( $\theta_{JA}$ ) is dependent on the design of the thermal vias. Without thermal vias and a thermal landing, the  $\theta_{JA}$  is approximately  $60^\circ\text{C/W}$  including localized PCB temperature increase.

**Table 3.2 Electrical Specifications**

| V <sub>DD</sub> = 3V to 3.6V, T <sub>A</sub> = -40°C to 125°C, all Typical values at T <sub>A</sub> = 27°C unless otherwise noted. |                     |     |      |     |      |  |
|--|---------------------|-----|------|-----|------|--|
| CHARACTERISTIC   | SYMBOL              | MIN | TYP  | MAX | UNIT | CONDITIONS   |
| DC Power   |                     |     |      |     |      |  |
| Supply Voltage   | V <sub>DD</sub>     | 3.0 | 3.3  | 3.6 | V    |  |
| Supply Current   | I <sub>DD</sub>     |     | 0.55 | 1   | mA   | Average current<br>Capacitive Sensing Active,<br>LEDs enabled                      |
|  | I <sub>SLEEP</sub>  |     | 200  | 250 | uA   | Sleep state active, 1 sensor<br>monitored; LED11 inactive<br>T <sub>A</sub> < 85°C |
|  | I <sub>DSLEEP</sub> |     | 4.5  | 10  | uA   | Deep Sleep, LED 11 inactive<br>T <sub>A</sub> < 40°C                               |
| Time to Communications   | t <sub>COMM</sub>   |     | 15   | 20  | ms   | Time from power applied to<br>communications active                                |

## Datasheet

Table 3.2 Electrical Specifications (continued)

| V <sub>DD</sub> = 3V to 3.6V, T <sub>A</sub> = -40°C to 125°C, all Typical values at T <sub>A</sub> = 27°C unless otherwise noted. |                     |                       |     |     |      |  |
|--|---------------------|-----------------------|-----|-----|------|--|
| CHARACTERISTIC   | SYMBOL              | MIN                   | TYP | MAX | UNIT | CONDITIONS   |
| Time to First Conversion   | t <sub>CONV</sub>   |                       | 400 | 500 | ms   | Time from power applied to first sensor sampled                    |
| Capacitive Touch Sensor  |                     |                       |     |     |      |  |
| Base Capacitance   | C <sub>BASE</sub>   | 5                     | 15  | 50  | pF   | Pad untouched  |
| Detectable Capacitive Shift  | ΔC <sub>TOUCH</sub> | 0.1                   | 0.4 | 2   | pF   | Pad touched  |
| Sample Time  | t <sub>TOUCH</sub>  |                       | 2.5 |     | ms   |  |
| Update Time  | Δt <sub>TOUCH</sub> |                       | 35  |     | ms   |  |
| Recalibration Interval   | Δt <sub>CAL</sub>   |                       | 8   |     | s    | Automatic Recalibration active, no touch active, default settings  |
| LED / GPIO Drivers (LED / GPIO 1 - 8)  |                     |                       |     |     |      |  |
| Duty Cycle   | DUTY <sub>LED</sub> | 0                     |     | 100 | %    | Programmable   |
| Drive Frequency  | f <sub>LED</sub>    |                       | 2   |     | kHz  |  |
| Sinking Current  | I <sub>SINK</sub>   |                       |     | 24  | mA   | V <sub>OL</sub> = 0.4  |
| Sourcing Current   | I <sub>SOURCE</sub> |                       |     | 24  | mA   | V <sub>OH</sub> = V <sub>DD</sub> - 0.4                            |
| Input High Voltage   | V <sub>IH</sub>     | 2.0                   |     |     | V    | LED / GPIO configured as input                                     |
| Input Low Voltage  | V <sub>IL</sub>     |                       |     | 0.8 | V    | LED / GPIO configured as input                                     |
| LED Drivers (LED 9 - LED 10)   |                     |                       |     |     |      |  |
| Duty Cycle   | DUTY <sub>LED</sub> | 0                     |     | 100 | %    | Programmable   |
| Drive Frequency  | f <sub>LED</sub>    |                       | 2   |     | kHz  |  |
| Sinking Current  | I <sub>SINK</sub>   |                       |     | 24  | mA   |  |
| Output Low Voltage   | V <sub>OL</sub>     |                       |     | 0.4 | V    | I <sub>SINK</sub> = 24mA   |
| LED11 Driver   |                     |                       |     |     |      |  |
| Duty Cycle   | DUTY <sub>LED</sub> | 0                     |     | 100 | %    | Programmable   |
| Drive Frequency  | f <sub>LED</sub>    |                       | 2   |     | kHz  |  |
| Sinking Current  | I <sub>SINK</sub>   |                       |     | 48  | mA   |  |
| Output Low Voltage   | V <sub>OL</sub>     |                       |     | 0.4 | V    | I <sub>SINK</sub> = 48mA   |
| I/O Pins - SMDATA, SMCLK, and ALERT Pins   |                     |                       |     |     |      |  |
| Output Low Voltage   | V <sub>OL</sub>     |                       |     | 0.4 | V    | I <sub>SINK_IO</sub> = 8mA   |
| Output High Voltage  | V <sub>OH</sub>     | V <sub>DD</sub> - 0.4 |     |     | V    | ALERT pin active high and asserted<br>I <sub>SOURCE_IO</sub> = 8mA |
| Input High Voltage   | V <sub>IH</sub>     | 2.0                   |     |     | V    |  |



Table 3.2 Electrical Specifications (continued)

| V <sub>DD</sub> = 3V to 3.6V, T <sub>A</sub> = -40°C to 125°C, all Typical values at T <sub>A</sub> = 27°C unless otherwise noted. |                       |     |     |     |      |   |
|--|-----------------------|-----|-----|-----|------|---|
| CHARACTERISTIC   | SYMBOL                | MIN | TYP | MAX | UNIT | CONDITIONS  |
| Input Low Voltage  | V <sub>IL</sub>       |     |     | 0.8 | V    |   |
| Leakage Current  | I <sub>LEAK</sub>     |     |     | ±5  | uA   | powered or unpowered<br>T <sub>A</sub> < 85°C<br>pull-up voltage ≤ 3.6V |
| RESET Pin  |                       |     |     |     |      |   |
| Input High Voltage   | V <sub>IH</sub>       | 2.0 |     |     | V    |   |
| Input Low Voltage  | V <sub>IL</sub>       |     |     | 0.8 | V    |   |
| RESET Filter Time  | t <sub>RST_FILT</sub> | 10  |     |     | ms   |   |
| RESET Pin release<br>to fully active<br>operation  | t <sub>RST_ON</sub>   |     | 400 | 500 | ms   |   |
| SMBus Timing   |                       |     |     |     |      |   |
| Input Capacitance  | C <sub>IN</sub>       |     | 5   |     | pF   |   |
| Clock Frequency  | f <sub>SMB</sub>      | 10  |     | 400 | kHz  |   |
| Spike Suppression  | t <sub>SP</sub>       |     |     | 50  | ns   |   |
| Bus free time Start to<br>Stop   | t <sub>BUF</sub>      | 1.3 |     |     | us   |   |
| Setup Time: Start  | t <sub>SU:STA</sub>   | 0.6 |     |     | us   |   |
| Setup Time: Stop   | t <sub>SU:STP</sub>   | 0.6 |     |     | us   |   |
| Data Hold Time   | t <sub>HD:DAT</sub>   | 0.6 |     | 6   | us   |   |
| Data Setup Time  | t <sub>SU:DAT</sub>   | 0.6 |     | 72  | us   |   |
| Clock Low Period   | t <sub>LOW</sub>      | 1.3 |     |     | us   |   |
| Clock High Period  | t <sub>HIGH</sub>     | 0.6 |     |     | us   |   |
| Clock/Data Fall time   | t <sub>FALL</sub>     |     |     | 300 | ns   | Min = 20+0.1C <sub>LOAD</sub> ns  |
| Clock/Data Rise time   | t <sub>RISE</sub>     |     |     | 300 | ns   | Min = 20+0.1C <sub>LOAD</sub> ns  |
| Capacitive Load  | C <sub>LOAD</sub>     |     |     | 400 | pF   | per bus line  |

## Chapter 4 Communications

The CAP1114 communicates via the SMBus or I<sup>2</sup>C communications protocols.

**APPLICATION NOTE:** Upon power up, the CAP1114 will not respond to any SMBus communications for 10ms. After this time, full functionality is available.

### 4.1 System Management Bus Protocol

The CAP1114 communicates with a host controller, such as an SMSC SIO, through the SMBus. The SMBus is a two-wire serial communication protocol between a computer host and its peripheral devices. A detailed timing diagram is shown in Figure 4.1. Stretching of the SMCLK signal is supported; however, the CAP1114 will not stretch the clock signal.

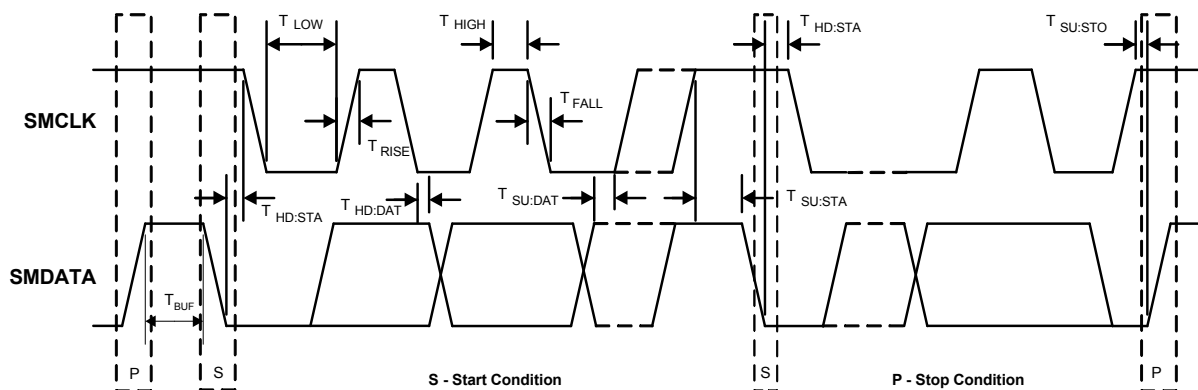

Figure 4.1 SMBus Timing Diagram

#### 4.1.1 SMBus Start Bit

The SMBus Start bit is defined as a transition of the SMBus Data line from a logic '1' state to a logic '0' state while the SMBus Clock line is in a logic '1' state.

#### 4.1.2 SMBus Address and RD / $\overline{\text{WR}}$ Bit

The SMBus Address Byte consists of the 7-bit client address followed by the RD /  $\overline{\text{WR}}$  indicator bit. If this RD /  $\overline{\text{WR}}$  bit is a logic '0', the SMBus Host is writing data to the client device. If this RD /  $\overline{\text{WR}}$  bit is a logic '1', the SMBus Host is reading data from the client device.

The CAP1114 responds to the slave address 0101\_000xb. Multiple addressing options are available. For more information contact SMSC.

#### 4.1.3 SMBus Data Bytes

All SMBus Data bytes are sent most significant bit first and composed of 8-bits of information.

#### 4.1.4 SMBus ACK and NACK Bits

The SMBus client will acknowledge all data bytes that it receives. This is done by the client device pulling the SMBus Data line low after the 8th bit of each byte that is transmitted. This applies to both the Write Byte and Block Write protocols.

The Host will NACK (not acknowledge) the last data byte to be received from the client by holding the SMBus data line high after the 8th data bit has been sent. For the Block Read protocol, the Host will ACK each data byte that it receives except the last data byte.

#### 4.1.5 SMBus Stop Bit

The SMBus Stop bit is defined as a transition of the SMBus Data line from a logic '0' state to a logic '1' state while the SMBus clock line is in a logic '1' state. When the CAP1114 detects an SMBus Stop bit, and it has been communicating with the SMBus protocol, it will reset its client interface and prepare to receive further communications.

#### 4.1.6 SMBus Time-out

The CAP1114 includes an SMBus time-out feature. Following a 30ms period of inactivity on the SMBus where the SMCLK pin is held low, the device will time-out and reset the SMBus interface.

The time-out function defaults to disabled. It can be enabled by setting the TIMEOUT bit in the Configuration register (see [Section 6.14](#)).

#### 4.1.7 SMBus and I<sup>2</sup>C Compliance

The major difference between SMBus and I<sup>2</sup>C devices is highlighted here. For complete compliance information, refer to the SMBus 2.0 specification.

1. Minimum frequency for SMBus communications is 10kHz.
2. The client protocol will reset if the clock is held low longer than 30ms.
3. Except when operating in Deep Sleep, the client protocol will reset if both the clock and the data line are high for longer than 150us (idle condition).
4. I<sup>2</sup>C devices do not support the Alert Response Address functionality (which is optional for SMBus).

## 4.2 SMBus Protocols

The CAP1114 is SMBus 2.0 compatible and supports Send Byte, Read Byte, Block Read, Receive Byte as valid protocols as shown below. The CAP1114 also supports the I<sup>2</sup>C block read and block write protocols.

All of the below protocols use the convention in [Table 4.1](#).

**Table 4.1 Protocol Format**

| DATA SENT TO DEVICE | DATA SENT TO THE HOST |
|---------------------|-----------------------|
| Data sent           | Data sent             |

#### 4.2.1 SMBus Write Byte

The Write Byte is used to write one byte of data to a specific register as shown in [Table 4.2](#).

**Table 4.2 Write Byte Protocol**

| START  | CLIENT ADDRESS | WR | ACK | REGISTER ADDRESS | ACK | REGISTER DATA | ACK | STOP   |
|--------|----------------|----|-----|------------------|-----|---------------|-----|--------|
| 1 -> 0 | 0101_000       | 0  | 0   | XXh              | 0   | XXh           | 0   | 0 -> 1 |

## Datasheet

## 4.2.2 Block Write

The Block Write is used to write multiple data bytes to a group of contiguous registers as shown in [Table 4.3](#). It is an extension of the Write Byte Protocol.

**APPLICATION NOTE:** When using the Block Write protocol, the internal address pointer will be automatically incremented after every data byte is received. It will wrap from FFh to 00h.

**Table 4.3 Block Write Protocol**

| START         | CLIENT ADDRESS | WR            | ACK | REGISTER ADDRESS | ACK           | REGISTER DATA | ACK    |
|---------------|----------------|---------------|-----|------------------|---------------|---------------|--------|
| 1 -> 0        | 0101_000       | 0             | 0   | XXh              | 0             | XXh           | 0      |
| REGISTER DATA | ACK            | REGISTER DATA | ACK | ...              | REGISTER DATA | ACK           | STOP   |
| XXh           | 0              | XXh           | 0   | ...              | XXh           | 0             | 0 -> 1 |

## 4.2.3 SMBus Read Byte

The Read Byte protocol is used to read one byte of data from the registers as shown in [Table 4.4](#).

**Table 4.4 Read Byte Protocol**

| START | CLIENT ADDRESS | WR | ACK | REGISTER ADDRESS | ACK | START | CLIENT ADDRESS | RD | ACK | REGISTER DATA | NACK | STOP   |
|-------|----------------|----|-----|------------------|-----|-------|----------------|----|-----|---------------|------|--------|
| 1->0  | 0101_000       | 0  | 0   | XXh              | 0   | 1->0  | 0101_000       | 1  | 0   | XXh           | 1    | 0 -> 1 |

## 4.2.4 Block Read

The Block Read is used to read multiple data bytes from a group of contiguous registers as shown in [Table 4.5](#). It is an extension of the Read Byte Protocol.

**APPLICATION NOTE:** When using the Block Read protocol, the internal address pointer will be automatically incremented after every data byte is received. It will wrap from FFh to 00h.

**Table 4.5 Block Read Protocol**

| START | CLIENT ADDRESS | WR  | ACK           | REGISTER ADDRESS | ACK           | START | CLIENT ADDRESS | RD            | ACK  | REGISTER DATA |
|-------|----------------|-----|---------------|------------------|---------------|-------|----------------|---------------|------|---------------|
| 1->0  | 0101_000       | 0   | 0             | XXh              | 0             | 1->0  | 0101_000       | 1             | 0    | XXh           |
| ACK   | REGISTER DATA  | ACK | REGISTER DATA | ACK              | REGISTER DATA | ACK   | ...            | REGISTER DATA | NACK | STOP          |
| 0     | XXh            | 0   | XXh           | 0                | XXh           | 0     | ...            | XXh           | 1    | 0 -> 1        |

## 4.2.5 SMBus Send Byte

The Send Byte protocol is used to set the internal address register pointer to the correct address location. No data is transferred during the Send Byte protocol as shown in [Table 4.6](#).

Table 4.6 Send Byte Protocol

| START  | CLIENT ADDRESS | WR | ACK | REGISTER ADDRESS | ACK | STOP   |
|--------|----------------|----|-----|------------------|-----|--------|
| 1 -> 0 | 0101_000       | 0  | 0   | XXh              | 0   | 0 -> 1 |

#### 4.2.6 SMBus Receive Byte

The Receive Byte protocol is used to read data from a register when the internal register address pointer is known to be at the right location (e.g. set via Send Byte). This is used for consecutive reads of the same register as shown in [Table 4.7](#).

Table 4.7 Receive Byte Protocol

| START  | CLIENT ADDRESS | RD | ACK | REGISTER DATA | NACK | STOP   |
|--------|----------------|----|-----|---------------|------|--------|
| 1 -> 0 | 0101_000       | 1  | 0   | XXh           | 1    | 0 -> 1 |

## Chapter 5 Product Description

The CAP1114 is a multiple channel Capacitive Touch sensor and LED Driver.

The CAP1114 contains up to 14 individual Capacitive Touch sensor inputs with programmable sensitivity for use in touch button and slider switch applications. Each sensor also contains automatic recalibration.

The CAP1114 also contains eleven (11) open drain LED drivers that offer full-on / off, variable rate breathing, and dimness controls. Eight (8) of these LEDs can double as GPIOs and support open-drain or push-pull operation. Capacitive buttons can be linked to LED outputs. Additionally, LEDs 1-7 may be optionally linked to Buttons 1-7 so that when a touch is detected, the LED is actuated.

The device communicates with a host controller using SMBus. The host controller may poll the device for updated information at any time or it may configure the device to flag an interrupt whenever a press is detected on any sensor.

Each sensor is polled by the device approximately every 35 ms. The host may also initiate a recalibration routine for one or more sensors or set up times and conditions so that the device automatically invokes the re-calibration routine.

The CAP1114 contains multiple power states including several low power operating states. In addition, it contains a user driven RESET pin to force the device to reset.

A typical system diagram is shown in [Figure 5.1](#).

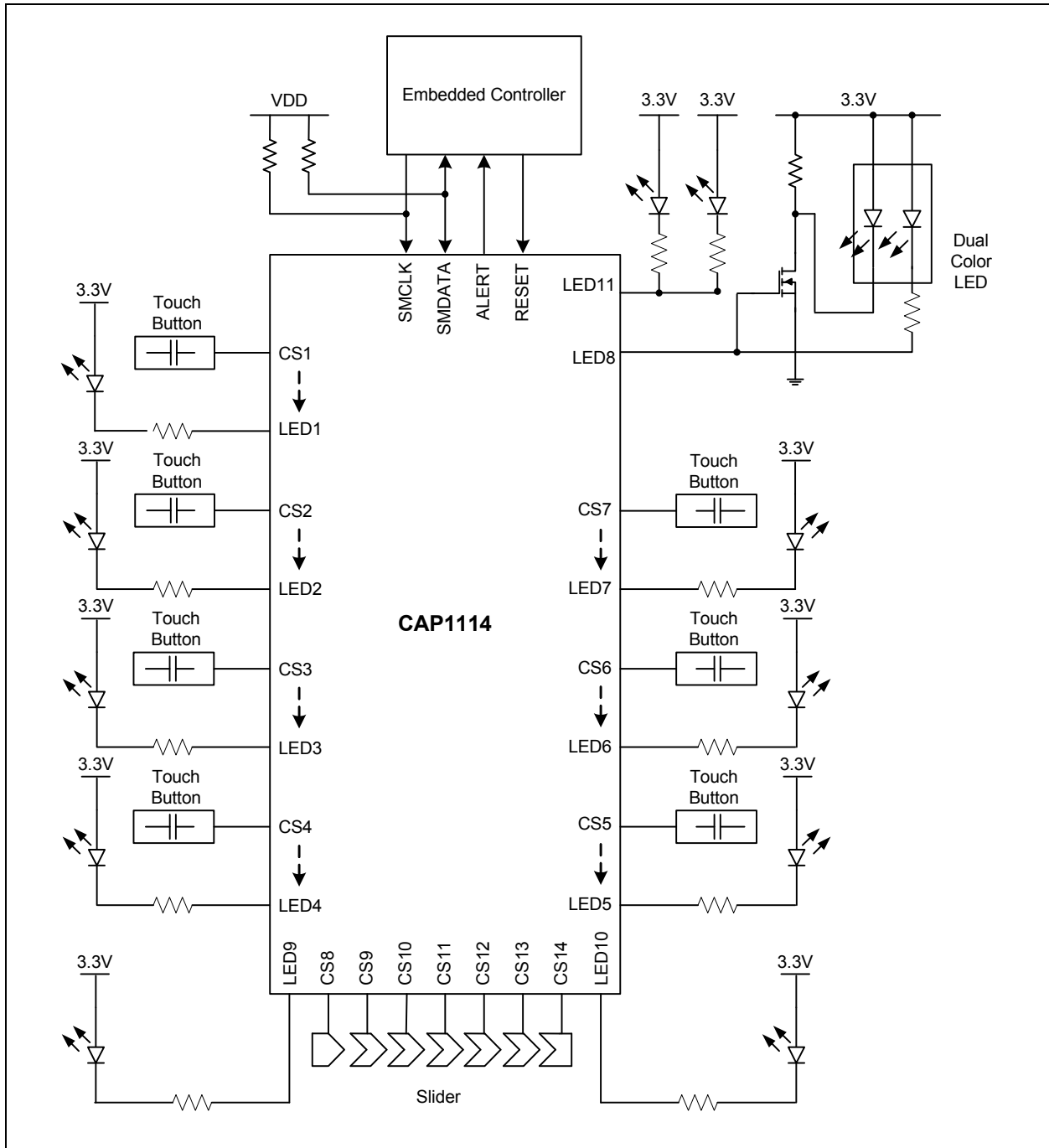

Figure 5.1 System Diagram for CAP1114

## 5.1 Power States

The CAP1114 has four operating states depending on the status of the SLEEP, DEACT, and DSLEEP bits (see Section 6.1). They are described below and summarized in Table 5.1. When the device transitions between power states, previously detected touches (for deactivated channels) are cleared and the status bits reset.

1. Fully Active - The device is fully active. It is monitoring all active Capacitive Sensor channels and driving all LED channels as defined.

**Datasheet**

2. Sleep - The device is in the Sleep state. It is monitoring a limited number of Capacitive Sensor channels (default 2). Interrupts will still be generated based on the active channels. The device will still respond to SMBus commands normally and can be returned to the Fully Active state by clearing the SLEEP bit. The LED11 channel is controlled via the PWR\_LED control (see [Section 6.1](#)). All other LEDs will not be affected.
3. Deep Sleep - The device is in Deep Sleep state. It is not monitoring any Capacitive Sensor channels or the SMBus. The LED11 channel is controlled via the PWR\_LED control (see [Section 6.1](#)). All other LEDs will be driven to their programmed non-actuated state and no PWM operations will be done.

When the device enters the Deep Sleep state, it will release control to the ALERT pin and will change the direction of the ALERT pin (i.e. the device will monitor the ALERT pin instead of driving it).

The device has two methods to exit the Deep Sleep state. They are:

- a. The ALERT pin is driven to its active state.
- b. Any SMBus communications are directed at the device.

When the device leaves the Deep Sleep state, it automatically returns to its previously defined state and clears the DSLEEP bit.

**Note:** When the device enters the Deep Sleep state, the Slider Position / Volumetric Data Register (06h) is cleared.

4. Inactive - The device is inactive. It is not monitoring any Capacitive Sensor channels. The device will still respond to SMBus commands normally and can be returned to Fully Active state by clearing the DEACT bit. All LEDs will have PWM controls suspended so they should be disabled prior to entering this state. If these LEDs are not disabled, the system will show excess current draw from these LEDs.

**Table 5.1 Power States**

| POWER STATE                       | DEACT | SLEEP | DSLEEP |
|-----------------------------------|-------|-------|--------|
| Fully Active                      | 0     | 0     | 0      |
| Deep Sleep waking to Fully Active | 0     | 0     | 1      |
| Sleep                             | 0     | 1     | 0      |
| Deep Sleep waking to Sleep        | 0     | 1     | 1      |
| Inactive                          | 1     | 0     | 0      |
| Deep Sleep waking to Inactive     | 1     | 0     | 1      |
| Inactive                          | 1     | 1     | 0      |
| Deep Sleep waking to Inactive     | 1     | 1     | 1      |

The priority of power control signals is:

1. DSLEEP - when set, will override DEACT, disable all LEDs except LED11 then disable SMBus communications.
2. DEACT - when set, will override the SLEEP controls. It will disable sensor measurement and all LEDs.
3. SLEEP - when set, will enable Sleep state.



## 5.2 RESET Pin

The RESET pin is an active high reset that is driven from an external source. The pin contains an internal delay timer ( $t_{RST\_FILT}$ ) that will block errant glitches on the RESET pin. The RESET pin must be driven high or low longer than this time before the CAP1114 will react to the pin state.

While the RESET pin is held high, all the internal blocks will be held in reset including the SMBus. All configuration settings will be reset to default states and all readings will be cleared. Furthermore, the device will be held in Deep Sleep that can only be removed by driving the RESET pin low.

Once the RESET pin is pulled low, the CAP1114 will begin operation as if a power-on-reset had occurred. When this happens, the RESET bit will be set and an interrupt will be generated.

## 5.3 LED Drivers

The CAP1114 contains eleven (11) LED Drivers. Each LED Driver is controlled independently of the others and may be linked to the corresponding Capacitive Touch Sensor input. All LED drivers will operate in one of the following modes. LED drivers 1 - 8 can be configured to operate with either push-pull or open-drain drive and may also be configured to operate as GPIOs. LED drivers 9 - 11 will only operate as open-drain drivers.

1. Direct - The LED is configured to be on or off when the corresponding input stimulus is on or off (or inverted). The brightness of the LED can be programmed from full off to full on (default). Additionally, the LED contains controls to individually configure ramping on, off, and turn-off delay.
2. Pulse 1 - The LED is configured to “Pulse” (transition ON-OFF-ON) a programmable number of times with programmable rate and min / max brightness. Further, the LED can be configured to be actuated upon a touch detection or release detection (or based on user written control registers).
3. Pulse 2 - The LED is configured to “Pulse” while actuated and then “Pulse” a programmable number of times with programmable rate and min / max brightness when the sensor is released.
4. Breathe - The LED is configured to transition continuously ON-OFF-ON (i.e. to “Breathe”) with a programmable rate and min / max brightness.

In addition to these four behaviors, all LED drivers support user initiated ramps and have an option to assert the ALERT pin when the ramp has reached its maximum or minimum settings.

LED11 operates differently than the other LED outputs in three ways. First, it is configured to drive up to two external LED channels simultaneously. Second, it is not disabled during the Sleep or Deep Sleep states of operation (see [Section 6.1](#)). The third and final difference is it allows for different behaviors when the device is in Fully Active state versus when the device is in Sleep or Deep Sleep state.

### 5.3.1 Linking LEDs to Capacitive Touch Sensors

LEDs 1 - 7 can be optionally linked to Capacitive Touch Sensors 1-7 so that when the sensor detects a button press, the corresponding LED will be actuated at one of the programmed responses.

LEDs 9 and 10 may be optionally linked to the Grouped Sensors to indicate a slide / tap / press and hold in the “Up” or “Down” directions.

## 5.4 Capacitive Touch Sensing

The CAP1114 contains 14 independent Capacitive Touch Sensor inputs. Each sensor has dynamic range to detect a change of capacitance due to a touch. Additionally, each sensor can be configured to be automatically and routinely re-calibrated.

## Datasheet

### 5.4.1 Multiple Button Presses

If multiple sensor buttons (with a programmable threshold - see [Section 6.23](#)) are simultaneously detected, only the first N buttons that are detected are flagged. All other buttons are ignored. Furthermore, the device remembers which buttons were legitimate so new touches are not detected so long as N buttons are pressed.

Likewise, if too many (based on the programmed threshold - see [Section 6.23](#)) grouped sensor presses are detected, the device will block all press detections on the grouped buttons and cancel any current presses as if the sensor had been released.

### 5.4.2 Lid Closure

To detect lid closure or other similar events, lid closure sensor thresholds can be set. A Lid Closure Event can be flagged based on either a minimum number of sensors or on specific sensors simultaneously exceeding the lid closure threshold. An interrupt can also be generated. During a Lid Closure Event, all touches are blocked.

### 5.4.3 Grouped Sensors (CS8 - CS14)

Capacitive Touch Sensors 8 through 14 inclusive may be grouped as a single entity (which is the default state). Each sensor is sampled independently; however, for purposes of activation, recalibration, and repeat rates, all of them are treated as one group. The Group also has different controls and allows for different behavior such as sliding, tapping, or press and hold.

The grouped sensors may be ungrouped as described in [Section 5.6](#).

### 5.4.4 Sensing Cycle

Each Capacitive Touch Sensor has controls to be activated and included in the sensing cycle. When the device is active, it automatically initiates a sensing cycle and repeats the cycle every time it finishes. The cycle polls through each active Sensor starting with CS1 and extending through CS14. As each Capacitive Touch Sensor is polled, its measurement is compared against a baseline “not touched” measurement. If the delta measurement is large enough, a touch is detected and an interrupt generated.

### 5.4.5 Proximity Detection

Sensor CS1 can be configured to detect changes in capacitance due to proximity of a touch. This circuitry detects the change of capacitance that is generated as an object approaches, but does not physically touch, the CS1 sensor. When proximity detection is enabled, the signal is boosted by 8x to detect very small capacitance changes. Separate controls determine averaging and sensitivity for proximity (see [Section 6.35, "Proximity Control Register"](#)).

### 5.4.6 Recalibrating Sensors

Each sensor is regularly recalibrated at an adjustable rate. By default, the recalibration routine stores the average 256 previous measurements and periodically updates the base “Not Touched” setting for the Capacitive Touch Sensor input. This routine is disabled automatically if a touch is detected so the touch does not factor into the base “Not Touched” setting.

### 5.4.7 Low Frequency Noise Detection

Each sensor has a noise detector that will sense if low frequency noise is injected onto the input with sufficient power to corrupt the readings. This noise detector has a fixed threshold above and below the rail that will trigger when noise is present. If low frequency noise is detected on a CS line, that sample is removed and not compared against the threshold.

### 5.4.8 RF Noise Detection

Each sensor also contains an integrated RF noise detector. This block will detect injected RF noise on the CS pin. The detector threshold is dependent upon the noise frequency. If RF noise is detected on a CS line, that sample is removed and not compared against the threshold.

## 5.5 Grouped Sensor Behavior

The CAP1114 Grouped sensors (CS8 - CS14) can be configured to function as a single entity that operates differently than the individual button sensors (for ungrouped behavior see [Section 5.6](#)). When configured as a group these sensors function as a slider and offer three different interface functions associated with it. These functions are Tap, Press and Hold, or a Slide.

For purposes of a Tap or Press and Hold event, the “DOWN” side of the Grouped sensors are defined as CS8, CS9 and CS10. The “UP” side of the Grouped Sensors are defined as CS12, CS13, and CS14. CS11 is neither “UP” nor “DOWN” and a tap or press and hold event on CS11 will not cause either UP or DOWN status bits to be set.

For purposes of a slide, the “DOWN” direction is decreasing in CS channel number. Conversely, the “UP” direction is increasing in CS number.

**APPLICATION NOTE:** The Grouped Sensors will cause either the UP or DOWN status bits to be set but not both at the same time. In the case that a sensor on both the “UP” side of the slider and the “DOWN” side of the slider are touched simultaneously, neither the UP nor DOWN status bits will be set.

### 5.5.1 Tap

If a touch on any Grouped sensor is detected and held for less than or equal to the M\_PRESS bit settings (default 245ms), a group press is detected, the TAP bit is set, and an interrupt is generated. Furthermore, the relative position on the slider is determined and the appropriate UP or DOWN status bits are set and the appropriate LED is actuated.

No further action is taken. If a slide is subsequently detected, the TAP status bit is cleared.

### 5.5.2 Press and Hold

If a touch on any Grouped sensor is held for longer than the M\_PRESS bit settings (default 245ms), a Group Touch is detected and an interrupt is generated. Furthermore, the relative position on the slider is determined and the appropriate UP or DOWN status bits are set, the PH bit is set, and the appropriate LED is actuated.

So long as the Grouped sensor is held, it will flag an interrupt at the programmed repeat rate (as determined by the RPT\_RATE\_PH bit settings) indefinitely. Once the touch has been removed, the Group is returned to its normal operating condition.

The M\_PRESS setting is important to distinguish between Tap, Press & Hold and Sliding. If M\_PRESS is set too low, a Press & Hold may be detected during a slow slide. This will cause user confusion as the Slide direction and LED may change. Longer M\_PRESS settings will ensure that the 3 Group behaviors are reliably distinct and will add more delay prior to the Press & Hold repeat interrupt generation.

### 5.5.3 Slider

The Grouped sensors have the capability to detect a slide in either the “UP” or “DOWN” direction as referenced by the sensor numbers that are used. For example, an “Up” direction slide would be detected if CS8 detected a touch, followed by CS9, then by CS10, etc. Likewise, a “Down” direction slide would be detected if CS10 detected a touch, followed by CS9, then by CS8, etc.

**Datasheet**

Slides in either direction are configured to flag an interrupt and to cause an LED to be actuated (separate for each direction). The Slide is detected independently of a Press and Hold or a Tap condition and only one condition may be present at any one time.

So long as a slide is maintained in either direction, it will flag an interrupt at the programmed repeat rate (as determined by the RPT\_RATE\_SL bit settings). If the slide is removed or changes direction, it will reset and return to normal operation.

**5.5.4 Relative Position**

The CAP1114 has the option to indicate the relative position of a touch on the Grouped sensors. This value is stored either as a scaled number from 2 to 98 indicating where a tap, press and hold, or the end of a slide was detected or as a 8-bit number that represents volumetric data. When configured to store volumetric data, the user may write a base setting at any time that is modified based on Grouped sensor behavior (see [Section 6.4](#)).

**5.5.5 Slider Velocity**

The repeat rate can be dynamically increased based on the speed of a slide. This permits slow sliding motions to have precise, step-by-step volume control and faster motions to generate increasingly fast volume changes.

Two techniques are employed to increase the number of interrupts generated based on speed. First, the slide speed is measured and the repeat rate is increased to provide more interrupts for the same distance traveled relative to a slower slide. Second, additional interrupts are generated immediately after the slide ends to further increase the change in volume. The number of additional interrupts is based on slide speed; both of these dynamic slider behaviors are controlled by the Slider Velocity Register.

**5.6 Ungrouped Sensor Behavior**

The CAP1114 Grouped sensors have the option to be used as individual buttons. When the group is broken (via the VOL\_UP\_DOWN bit - see [Section 6.33](#)), buttons CS8 and CS14 will adopt one type of behavior while buttons CS9 - CS13 will adopt another. In all cases, a slide will not be detected.

**5.6.1 CS9 - CS13 Ungrouped Behavior**

These buttons will cause the corresponding status bit in the Button Status 2 register (see [Section 6.2](#)) to be asserted when a touch is detected. This touch detection uses the button queue and button repeat rate settings. They will use the slider maximum duration and multiple touch settings.

**5.6.2 CS8 and CS14 Ungrouped Behavior**

CS8 and CS14 will generate interrupts based on the duration of the touch detected, similar to a Tap and Press and Hold events. Furthermore, these sensors will generate interrupts at the Grouped Sensors repeat rate based on whether a Tap or Press and Hold event has been detected.

If a touch is detected on CS8, the DOWN status bit will be set in addition to either TAP or PH.

If a touch is detected on CS14, the UP status bit will be set in addition to either TAP or PH.

Based on the multiple button touch settings (see [Section 6.23](#)), both CS8 and CS14 may detect a touch simultaneously and both UP and DOWN status bits may be set.

**5.7 ALERT Pin**

The ALERT pin is an active high output that is driven high when an interrupt event is detected. It is also used to wake the device from Deep Sleep state.

Whenever an interrupt is generated, the INT bit (see [Section 6.1](#)) is set. The ALERT pin is cleared when INT bit is cleared by the user. Additionally, when the INT bit is cleared by the user, status bits are cleared only if no press is detected.

### 5.7.1 Button Interrupt Behavior

For non-grouped buttons, an interrupt is generated when a touch is detected. If the repeat rate is enabled (see [Section 6.14](#)), then, so long as the touch is held, another interrupt will be generated based on the programmed repeat rate (see [Figure 5.2](#)) and upon release.

### 5.7.2 Grouped Sensor Interrupt Behavior

For grouped sensors, an interrupt is generated upon initial detection of a tap, slide, or press and hold event. Then, subsequent interrupts are generated as follows:

1. For a slide event, an interrupt is generated based on the programmed repeat rate as well as the velocity of the slide operation. See [Figure 5.6](#) and [Figure 5.7](#). Additional interrupts are generated after the slide has finished. These extra interrupts are generated every round robin cycle (~35ms) and the number is determined by the speed of the slide.
2. For a tap event there are no further interrupts. See [Figure 5.4](#).
3. For a press and hold event, interrupts are generated based on the programmed repeat rate. If the repeat rate is disabled, no further interrupts are generated. See [Figure 5.5](#).

### 5.7.3 Wake from Deep Sleep

When the ALERT pin is driven high from an external source, it is also used to wake the device from the Deep Sleep power state. When the device enters the Deep Sleep power state, the ALERT pin output is put into a high-Z mode. It requires a pull-down resistor to pull it to the inactive state. Furthermore, the CAP1114 will wait 5ms before it samples the ALERT pin for wake activity.

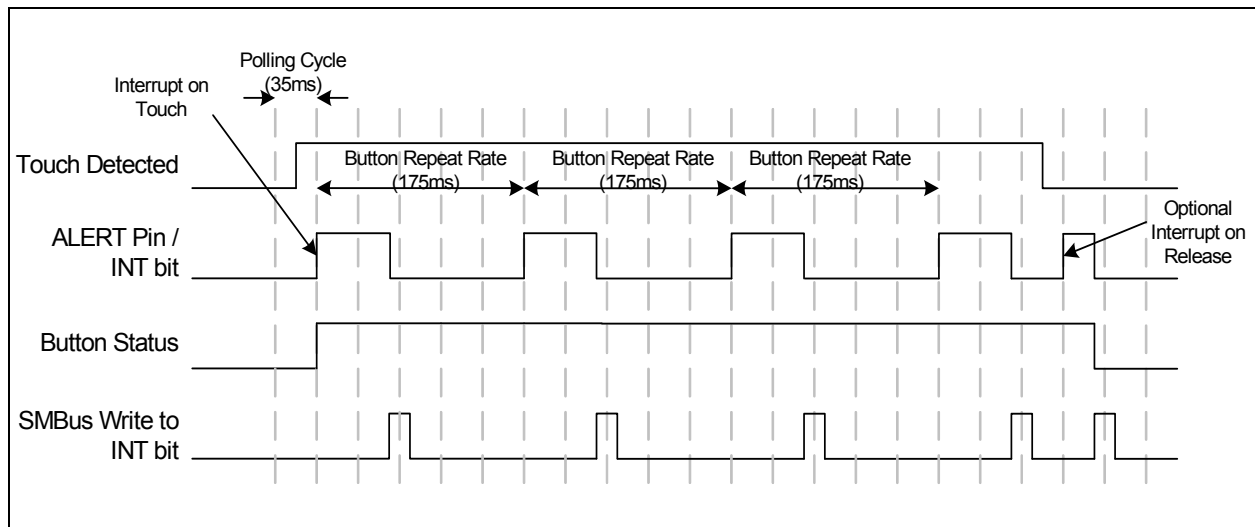

Figure 5.2 Button Interrupt Behavior - Repeat Rate Enabled (default)

Datasheet

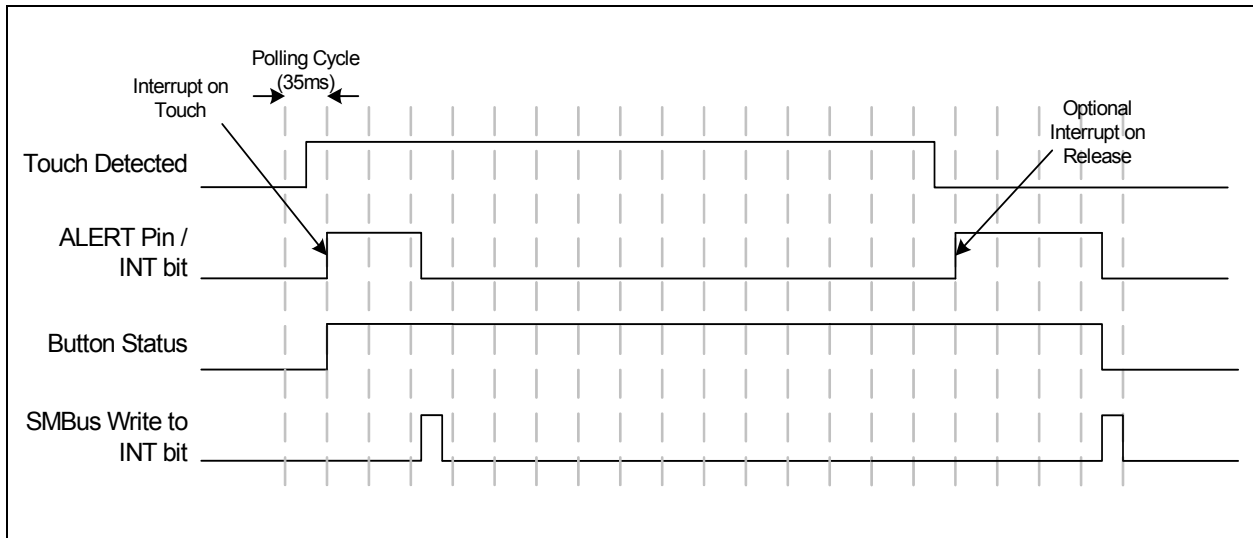

Figure 5.3 Button Interrupt Behavior - No Repeat Rate Enabled

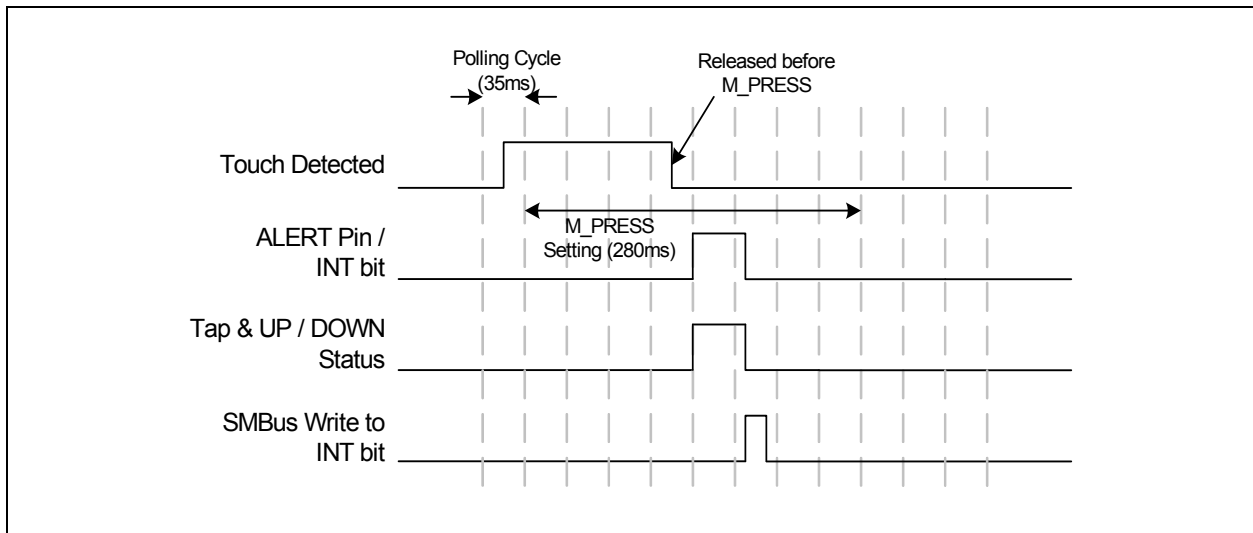

Figure 5.4 Tap Interrupt Behavior

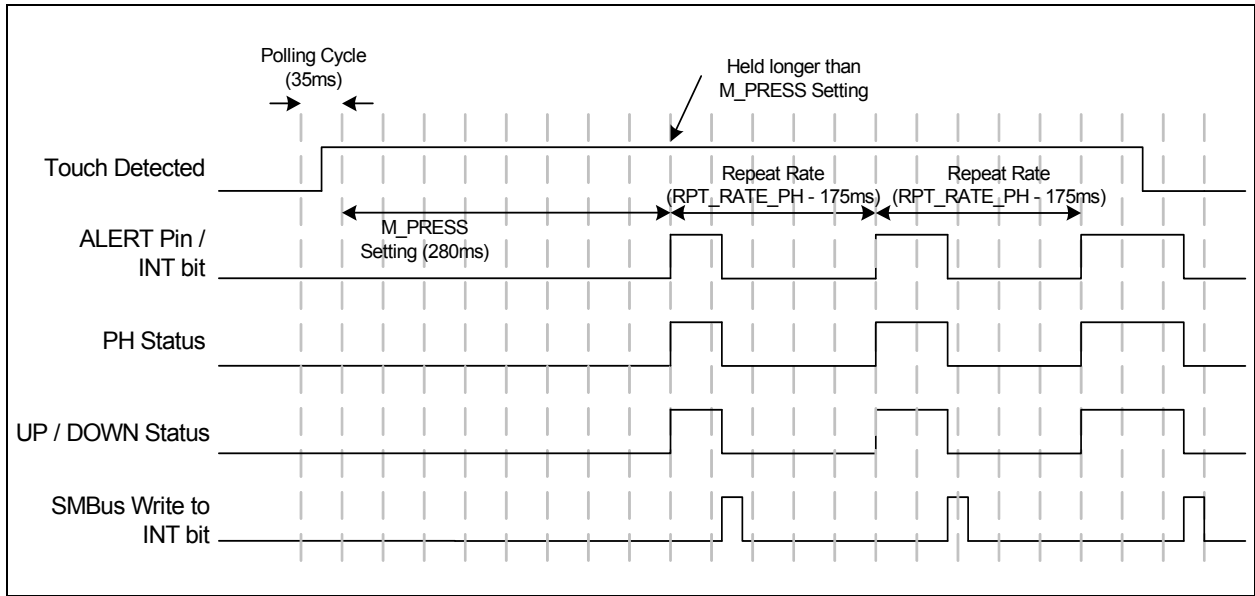

Figure 5.5 Press and Hold Interrupt Behavior

Datasheet

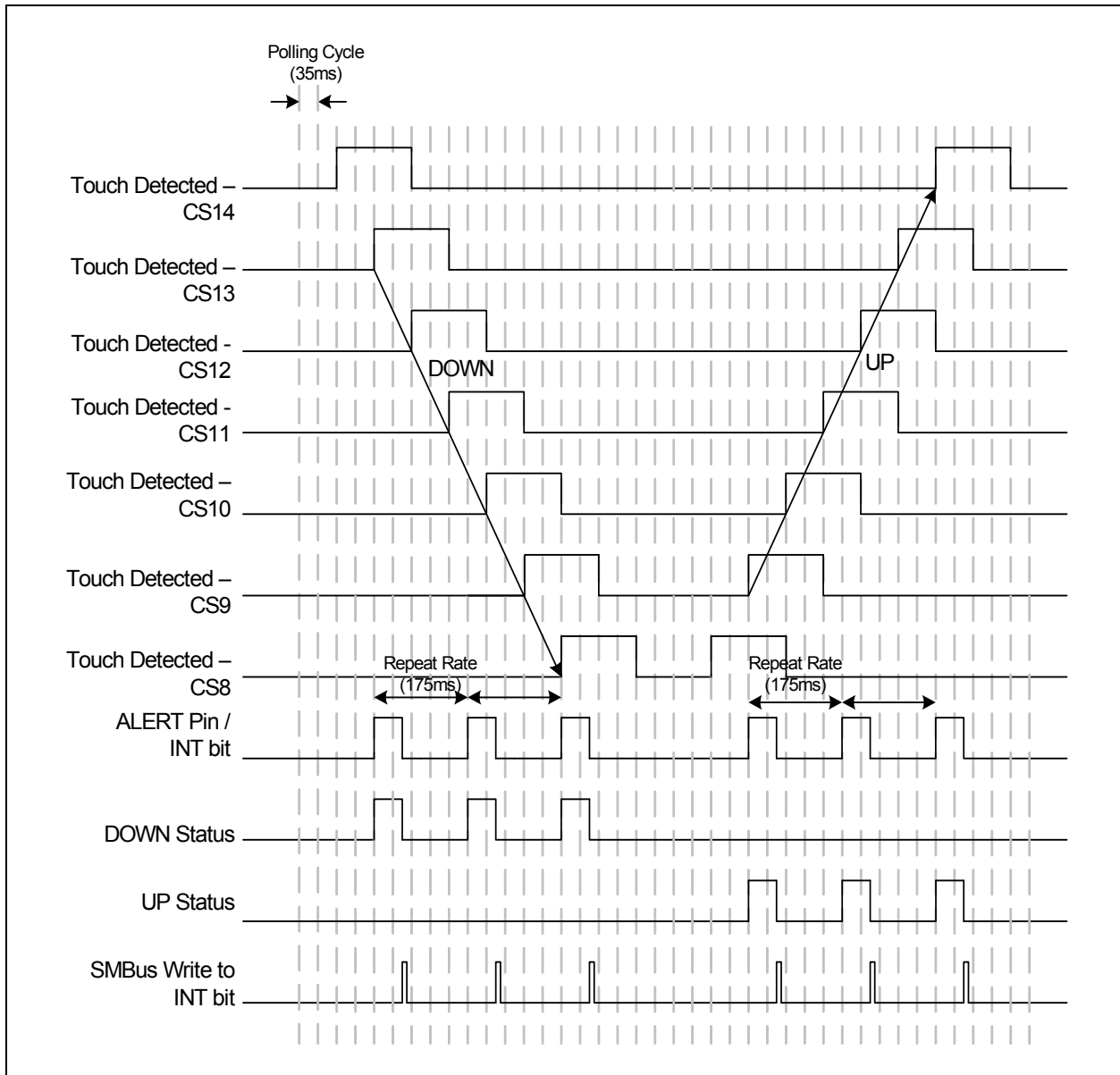

Figure 5.6 Slide Interrupt Behavior - No Acceleration



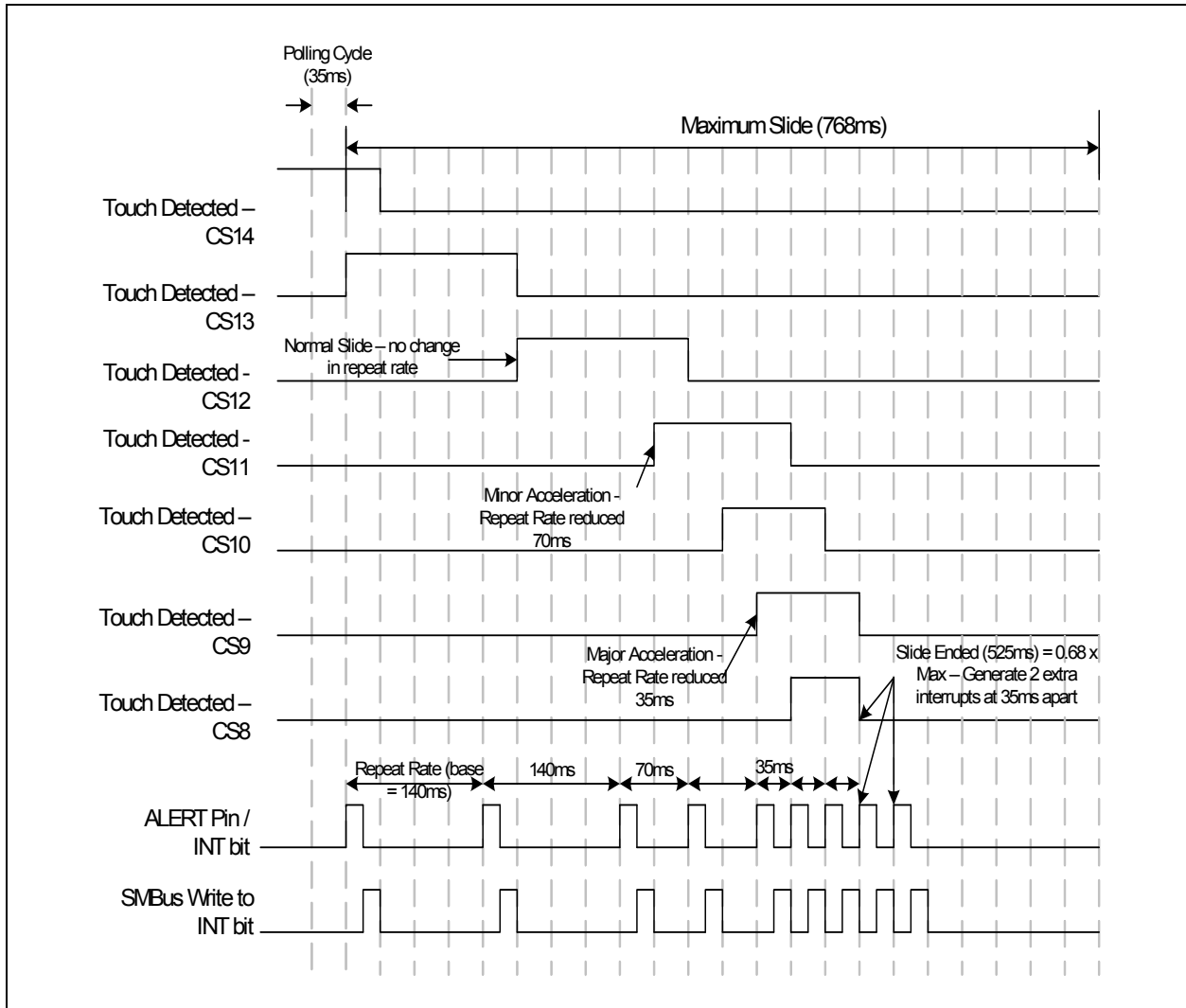

Figure 5.7 Slide Interrupt Behavior - Acceleration Example

## Chapter 6 Register Description

The registers shown in [Table 6.1](#) are accessible through the SMBus. An entry of '-' indicates that the bit is not used and will always read '0'.

**Table 6.1 Register Set in Hexadecimal Order**

| REGISTER ADDRESS | R/W       | REGISTER NAME                     | FUNCTION  | DEFAULT VALUE | PAGE                    |
|------------------|-----------|-----------------------------------|---|---------------|-------------------------|
| 00h              | R/W       | Main Status Control               | Controls general power states   | 00h           | <a href="#">Page 41</a> |
| 03h              | R         | Button Status 1                   | Returns the state of the Cap Sensor group and buttons 1 - 6 and slider controls | 00h           | <a href="#">Page 42</a> |
| 04h              | R         | Button Status 2                   | Returns the state of buttons 7 - 14   | 00h           | <a href="#">Page 42</a> |
| 05h              | R         | Build Revision                    | Stores the functional revision of the device build                              | 10h           | <a href="#">Page 43</a> |
| 06h              | R-C / R/W | Slider Position / Volumetric Data | Returns the relative position of a press on the slider or volumetric data       | 00h           | <a href="#">Page 43</a> |
| 08h              | R         | Vendor ID                         | Stores a fixed value that identifies SMSC                                       | 5Dh           | <a href="#">Page 45</a> |
| 09h              | R/W       | Volumetric Step                   | Controls the step used for volumetric data increases for a slide                | 01h           | <a href="#">Page 45</a> |
| 0Ah              | R         | Noise Status 1                    | Stores the noise flags for sensors 1 - 7  | 00h           | <a href="#">Page 45</a> |
| 0Bh              | R         | Noise Status 2                    | Stores the noise flags for sensors 8 - 14                                       | 00h           | <a href="#">Page 45</a> |
| 0Ch              | R         | Lid Closure Status 1              | Stores lid closure status bits for sensors 1 - 7                                | 00h           | <a href="#">Page 46</a> |
| 0Dh              | R         | Lid Closure Status 2              | Stores lid closure status bits for sensors 8 - 14                               | 00h           | <a href="#">Page 46</a> |
| 0Eh              | R-C       | GPIO Status                       | Stores the status of LED1 / GPIO1 through LED8 / GPIO8 pins                     | 00h           | <a href="#">Page 46</a> |
| 0Fh              | R-C       | Group Status                      | Returns the state of the Grouped sensors  | 00h           | <a href="#">Page 47</a> |
| 10h              | R         | Sensor 1 Delta Count              | Stores the delta count for CS1  | 00h           | <a href="#">Page 47</a> |
| 11h              | R         | Sensor 2 Delta Count              | Stores the delta count for CS2  | 00h           | <a href="#">Page 47</a> |
| 12h              | R         | Sensor 3 Delta Count              | Stores the delta count for CS3  | 00h           | <a href="#">Page 47</a> |
| 13h              | R         | Sensor 4 Delta Count              | Stores the delta count for CS4  | 00h           | <a href="#">Page 47</a> |

Table 6.1 Register Set in Hexadecimal Order (continued)

| REGISTER ADDRESS | R/W | REGISTER NAME         | FUNCTION   | DEFAULT VALUE | PAGE                    |
|------------------|-----|-----------------------|--|---------------|-------------------------|
| 14h              | R   | Sensor 5 Delta Count  | Stores the delta count for CS5   | 00h           | <a href="#">Page 47</a> |
| 15h              | R   | Sensor 6 Delta Count  | Stores the delta count for CS6   | 00h           | <a href="#">Page 47</a> |
| 16h              | R   | Sensor 7 Delta Count  | Stores the delta count for CS7   | 00h           | <a href="#">Page 47</a> |
| 17h              | R   | Sensor 8 Delta Count  | Stores the delta count for CS8   | 00h           | <a href="#">Page 47</a> |
| 18h              | R   | Sensor 9 Delta Count  | Stores the delta count for CS9   | 00h           | <a href="#">Page 47</a> |
| 19h              | R   | Sensor 10 Delta Count | Stores the delta count for CS10  | 00h           | <a href="#">Page 47</a> |
| 1Ah              | R   | Sensor 11 Delta Count | Stores the delta count for CS11  | 00h           | <a href="#">Page 47</a> |
| 1Bh              | R   | Sensor 12 Delta Count | Stores the delta count for CS12  | 00h           | <a href="#">Page 47</a> |
| 1Ch              | R   | Sensor 13 Delta Count | Stores the delta count for CS13  | 00h           | <a href="#">Page 47</a> |
| 1Dh              | R   | Sensor 14 Delta Count | Stores the delta count for CS14  | 00h           | <a href="#">Page 47</a> |
| 1Eh              | R/W | Queue Control         | Controls how many samples must exceed touch threshold for button press detections              | 03h           | <a href="#">Page 48</a> |
| 1Fh              | R/W | Data Sensitivity      | Controls the sensitivity of the threshold and delta counts and data scaling of the base counts | 2Fh           | <a href="#">Page 49</a> |
| 20h              | R/W | Configuration         | Controls some recalibration and LED controls   | 29h           | <a href="#">Page 51</a> |
| 21h              | R/W | Sensor Enable         | Controls whether the Capacitive Touch Sensor group and button inputs 1 - 7 are sampled         | FFh           | <a href="#">Page 52</a> |
| 22h              | R/W | Button Configuration  | Controls reset delay and auto-repeat delay for buttons   | A4h           | <a href="#">Page 53</a> |
| 23h              | R/W | Group Configuration 1 | Controls the detection dwell time before a press is detected within the group                  | 47h           | <a href="#">Page 54</a> |
| 24h              | R/W | Group Configuration 2 | Controls reset delay and auto-repeat delay for grouped sensors                                 | D4h           | <a href="#">Page 55</a> |
| 25h              | R/W | Calibration Enable    | Controls automatic calibration for grouped sensors and sensors 1 - 7                           | FFh           | <a href="#">Page 56</a> |
| 26h              | R/W | Calibration Activate  | Activates manual re-calibration for grouped sensors and sensors 1 - 7                          | 00h           | <a href="#">Page 56</a> |

## Datasheet

Table 6.1 Register Set in Hexadecimal Order (continued)

| REGISTER ADDRESS | R/W | REGISTER NAME                | FUNCTION  | DEFAULT VALUE | PAGE                    |
|------------------|-----|------------------------------|---|---------------|-------------------------|
| 27h              | R/W | Interrupt Enable 1           | Enables Interrupts associated with the grouped sensors and sensors 1 - 7                        | FFh           | <a href="#">Page 58</a> |
| 28h              | R/W | Interrupt Enable 2           | Enables Interrupts associated with GPIOs 1 - 8  | 00h           | <a href="#">Page 58</a> |
| 29h              | R/W | Sleep Channel Control        | Determines the number and which channels are measured during Sleep                              | 00h           | <a href="#">Page 59</a> |
| 2Ah              | R/W | Multiple Press Configuration | Determines the number of simultaneous presses to flag a multiple press condition                | 82h           | <a href="#">Page 60</a> |
| 2Bh              | R/W | Lid Closure Configuration    | Controls Lid Closure detection and operation  | 00h           | <a href="#">Page 61</a> |
| 2Ch              | R/W | Lid Closure Queue Control    | Controls how many samples must exceed the lid closure threshold for Button and Slider operation | 02h           | <a href="#">Page 61</a> |
| 2Dh              | R/W | Lid Closure Pattern 1        | Stores pattern bits for lid closure detection for channels 1 - 7                                | 7Fh           | <a href="#">Page 62</a> |
| 2Eh              | R/W | Lid Closure Pattern 2        | Stores pattern bits for lid closure detection for channels 8 - 14                               | 7Fh           | <a href="#">Page 62</a> |
| 2Fh              | R/W | Recalibration Configuration  | Determines re-calibration timing and sampling window  | 93h           | <a href="#">Page 63</a> |
| 30h              | R/W | Sensor 1 Threshold           | Stores the delta count threshold to determine a touch for Capacitive Touch Sensor 1             | 40h           | <a href="#">Page 64</a> |
| 31h              | R/W | Sensor 2 Threshold           | Stores the delta count threshold to determine a touch for Capacitive Touch Sensor 2             | 40h           | <a href="#">Page 64</a> |
| 32h              | R/W | Sensor 3 Threshold           | Stores the delta count threshold to determine a touch for Capacitive Touch Sensor 3             | 40h           | <a href="#">Page 64</a> |
| 33h              | R/W | Sensor 4 Threshold           | Stores the delta count threshold to determine a touch for Capacitive Touch Sensor 4             | 40h           | <a href="#">Page 64</a> |
| 34h              | R/W | Sensor 5 Threshold           | Stores the delta count threshold to determine a touch for Capacitive Touch Sensor 5             | 40h           | <a href="#">Page 64</a> |
| 35h              | R/W | Sensor 6 Threshold           | Stores the delta count threshold to determine a touch for Capacitive Touch Sensor 6             | 40h           | <a href="#">Page 64</a> |
| 36h              | R/W | Sensor 7 Threshold           | Stores the delta count threshold to determine a touch for Capacitive Touch Sensor 7             | 40h           | <a href="#">Page 64</a> |

Table 6.1 Register Set in Hexadecimal Order (continued)

| REGISTER ADDRESS | R/W | REGISTER NAME                       | FUNCTION  | DEFAULT VALUE | PAGE                    |
|------------------|-----|-------------------------------------|---|---------------|-------------------------|
| 37h              | R/W | Group Threshold                     | Stores the delta count threshold to determine a touch on any of the Grouped Sensors         | 40h           | <a href="#">Page 64</a> |
| 38h              | R/W | Button Noise Threshold 1            | Stores controls for selecting the noise threshold for buttons 1 - 4                         | AAh           | <a href="#">Page 65</a> |
| 39h              | R/W | Button Noise Threshold 2            | Stores controls for selecting the noise threshold for buttons 5 - 7 and the Grouped sensors | AAh           | <a href="#">Page 65</a> |
| 3Ah              | R/W | Lid Closure Threshold 1             | Stores controls for selecting the lid closure threshold for buttons 1 - 4                   | AAh           | <a href="#">Page 66</a> |
| 3Bh              | R/W | Lid Closure Threshold 2             | Stores controls for selecting the lid closure threshold for buttons 5 - 8                   | AAh           | <a href="#">Page 66</a> |
| 3Ch              | R/W | Lid Closure Threshold 3             | Stores controls for selecting the lid closure threshold for buttons 9 - 12                  | AAh           | <a href="#">Page 66</a> |
| 3Dh              | R/W | Lid Closure Threshold 4             | Stores controls for selecting the lid closure threshold for buttons 13 - 14                 | 0Ah           | <a href="#">Page 66</a> |
| 3Eh              | R/W | Slider Velocity Configuration       | Determines speed parameters for the slider  | C5h           | <a href="#">Page 67</a> |
| 3Fh              | R/W | Digital Recalibration               | Forces digital recalibration for all sensors  | 00h           | <a href="#">Page 69</a> |
| 40h              | R/W | Configuration 2                     | Stores additional controls for general operation  | 00h           | <a href="#">Page 70</a> |
| 41h              | R/W | Grouped Channel Sensor Enable       | Stores controls to enable some or all sensors in the group                                  | 7Fh           | <a href="#">Page 71</a> |
| 42h              | R/W | Proximity Control                   | Controls the sensitivity settings for CS1   | 02h           | <a href="#">Page 72</a> |
| 46h              | R/W | Grouped Sensor Calibration Activate | Stores controls to force a calibration on the individual sensors in the Group               | 00h           | <a href="#">Page 56</a> |
| 4Eh              | R/W | Sampling Channel Select             | Controls which channels are affected by the Sampling Configuration Register settings        | 00h           | <a href="#">Page 73</a> |
| 4Fh              | R/W | Sampling Configuration              | Changes the sampling time for one or more input channels                                    | 00h           | <a href="#">Page 73</a> |
| 50h              | R   | Sensor 1 Base Count                 | Stores the reference count value for sensor 1   | 00h           | <a href="#">Page 74</a> |
| 51h              | R   | Sensor 2 Base Count                 | Stores the reference count value for sensor 2   | 00h           | <a href="#">Page 74</a> |
| 52h              | R   | Sensor 3 Base Count                 | Stores the reference count value for sensor 3   | 00h           | <a href="#">Page 74</a> |
| 53h              | R   | Sensor 4 Base Count                 | Stores the reference count value for sensor 4   | 00h           | <a href="#">Page 74</a> |

## Datasheet

Table 6.1 Register Set in Hexadecimal Order (continued)

| REGISTER ADDRESS | R/W | REGISTER NAME                   | FUNCTION   | DEFAULT VALUE | PAGE                    |
|------------------|-----|---------------------------------|--|---------------|-------------------------|
| 54h              | R   | Sensor 5 Base Count             | Stores the reference count value for sensor 5                  | 00h           | <a href="#">Page 74</a> |
| 55h              | R   | Sensor 6 Base Count             | Stores the reference count value for sensor 6                  | 00h           | <a href="#">Page 74</a> |
| 56h              | R   | Sensor 7 Base Count             | Stores the reference count value for sensor 7                  | 00h           | <a href="#">Page 74</a> |
| 57h              | R   | Sensor 8 Base Count             | Stores the reference count value for sensor 8                  | 00h           | <a href="#">Page 74</a> |
| 58h              | R   | Sensor 9 Base Count             | Stores the reference count value for sensor 9                  | 00h           | <a href="#">Page 74</a> |
| 59h              | R   | Sensor 10 Base Count            | Stores the reference count value for sensor 10                 | 00h           | <a href="#">Page 74</a> |
| 5Ah              | R   | Sensor 11 Base Count            | Stores the reference count value for sensor 11                 | 00h           | <a href="#">Page 74</a> |
| 5Bh              | R   | Sensor 12 Base Count            | Stores the reference count value for sensor 12                 | 00h           | <a href="#">Page 74</a> |
| 5Ch              | R   | Sensor 13 Base Count            | Stores the reference count value for sensor 13                 | 00h           | <a href="#">Page 74</a> |
| 5Dh              | R   | Sensor 14 Base Count            | Stores the reference count value for sensor 14                 | 00h           | <a href="#">Page 74</a> |
| 60h              | R   | LED Status 1                    | Stores status bits for LEDs 1 - 8                              | 00h           | <a href="#">Page 75</a> |
| 61h              | R   | LED Status 2                    | Stores status bits for LEDs 9 - 11                             | 00h           | <a href="#">Page 75</a> |
| 70h              | R/W | LED / GPIO Direction            | Controls the direction for LED1 / GPIO1 through LED8 / GPIO8   | 00h           | <a href="#">Page 76</a> |
| 71h              | R/W | LED / GPIO Output Type          | Controls the output type for LED1 / GPIO1 through LED8 / GPIO8 | 00h           | <a href="#">Page 77</a> |
| 72h              | R   | GPIO Input                      | Stores the pin state of LED1 / GPIO1 through LED8 / GPIO8      | 00h           | <a href="#">Page 77</a> |
| 73h              | R/W | LED Output Control 1            | Controls the output state of the LED drivers 1 - 8             | 00h           | <a href="#">Page 78</a> |
| 74h              | R/W | LED Output Control 2            | Controls the output state of the LED drivers 9 - 11            | 00h           | <a href="#">Page 78</a> |
| 75h              | R/W | LED Polarity 1                  | Controls the output polarity of LEDs 1 - 8                     | 00h           | <a href="#">Page 79</a> |
| 76h              | R/W | LED Polarity 2                  | Controls the output polarity of LEDs 9 - 11                    | 00h           | <a href="#">Page 79</a> |
| 77h              | R/W | Linked LED Transition Control 1 | Controls transition effects of LEDs 1 - 7 when linked          | 00h           | <a href="#">Page 81</a> |
| 78h              | R/W | Linked LED Transition Control 2 | Controls transition effects of LEDs 9 - 10 when linked         | 00h           | <a href="#">Page 81</a> |

Table 6.1 Register Set in Hexadecimal Order (continued)

| REGISTER ADDRESS | R/W | REGISTER NAME          | FUNCTION  | DEFAULT VALUE | PAGE                    |
|------------------|-----|------------------------|---|---------------|-------------------------|
| 79h              | R/W | LED Mirror Control 1   | Controls the duty cycle mirroring of LEDs 1 - 8                                       | 00h           | <a href="#">Page 82</a> |
| 7Ah              | R/W | LED Mirror Control 2   | Controls the duty cycle mirroring of LEDs 9 - 11                                      | 00h           | <a href="#">Page 82</a> |
| 80h              | R/W | Sensor LED Linking     | Controls linking of CS1 - CS7 to LED channels   | 00h           | <a href="#">Page 83</a> |
| 81h              | R/W | LED Behavior 1         | Controls the behavior and response of LEDs 1 - 4                                      | 00h           | <a href="#">Page 84</a> |
| 82h              | R/W | LED Behavior 2         | Controls the behavior and response of LEDs 5 - 8                                      | 00h           | <a href="#">Page 84</a> |
| 83h              | R/W | LED Behavior 3         | Controls the behavior and response of LEDs 9 - 11                                     | 00h           | <a href="#">Page 84</a> |
| 84h              | R/W | LED Pulse 1 Period     | Controls the period of each breathe during a pulse                                    | 20h           | <a href="#">Page 86</a> |
| 85h              | R/W | LED Pulse 2 Period     | Controls the period of breath and pulse release operation                             | 14h           | <a href="#">Page 88</a> |
| 86h              | R/W | LED Breathe Period     | Controls the period of an LED breathe operation                                       | 5Dh           | <a href="#">Page 89</a> |
| 88h              | R/W | LED Configuration      | Controls the number of pulses for the Pulse 1 and Pulse 2 LED behaviors               | 24h           | <a href="#">Page 89</a> |
| 90h              | R/W | LED Pulse 1 Duty Cycle | Determines the min and max duty cycle for the pulse operation                         | F0h           | <a href="#">Page 90</a> |
| 91h              | R/W | LED Pulse 2 Duty Cycle | Determines the min and max duty cycle for the breathe and pulse release operation     | F0h           | <a href="#">Page 90</a> |
| 92h              | R/W | LED Breathe Duty Cycle | Determines the min and max duty cycle for the breathe operation                       | F0h           | <a href="#">Page 90</a> |
| 93h              | R/W | LED Direct Duty Cycle  | Determines the min and max duty cycle for Direct mode LED operation                   | F0h           | <a href="#">Page 90</a> |
| 94h              | R/W | LED Direct Ramp Rates  | Determines the rising and falling edge ramp rates of the LED                          | 00h           | <a href="#">Page 91</a> |
| 95h              | R/W | LED Off Delay          | Determines the off delay for all LED behaviors  | 00h           | <a href="#">Page 92</a> |
| B1h              | R   | Sensor 1 Calibration   | Stores the high byte of the 10-bit value used to drive the analog portion of sensor 1 | 00h           | <a href="#">Page 94</a> |
| B2h              | R   | Sensor 2 Calibration   | Stores the high byte of the 10-bit value used to drive the analog portion of sensor 2 | 00h           | <a href="#">Page 94</a> |
| B3h              | R   | Sensor 3 Calibration   | Stores the high byte of the 10-bit value used to drive the analog portion of sensor 3 | 00h           | <a href="#">Page 94</a> |

## Datasheet

Table 6.1 Register Set in Hexadecimal Order (continued)

| REGISTER ADDRESS | R/W | REGISTER NAME         | FUNCTION   | DEFAULT VALUE | PAGE                    |
|------------------|-----|-----------------------|--|---------------|-------------------------|
| B4h              | R   | Sensor 4 Calibration  | Stores the high byte of the 10-bit value used to drive the analog portion of sensor 4  | 00h           | <a href="#">Page 94</a> |
| B5h              | R   | Sensor 5 Calibration  | Stores the high byte of the 10-bit value used to drive the analog portion of sensor 5  | 00h           | <a href="#">Page 94</a> |
| B6h              | R   | Sensor 6 Calibration  | Stores the high byte of the 10-bit value used to drive the analog portion of sensor 6  | 00h           | <a href="#">Page 94</a> |
| B7h              | R   | Sensor 7 Calibration  | Stores the high byte of the 10-bit value used to drive the analog portion of sensor 7  | 00h           | <a href="#">Page 94</a> |
| B8h              | R   | Sensor 8 Calibration  | Stores the high byte of the 10-bit value used to drive the analog portion of sensor 8  | 00h           | <a href="#">Page 94</a> |
| B9h              | R   | Sensor 9 Calibration  | Stores the high byte of the 10-bit value used to drive the analog portion of sensor 9  | 00h           | <a href="#">Page 94</a> |
| BAh              | R   | Sensor 10 Calibration | Stores the high byte of the 10-bit value used to drive the analog portion of sensor 10 | 00h           | <a href="#">Page 94</a> |
| BBh              | R   | Sensor 11 Calibration | Stores the high byte of the 10-bit value used to drive the analog portion of sensor 11 | 00h           | <a href="#">Page 94</a> |
| BCh              | R   | Sensor 12 Calibration | Stores the high byte of the 10-bit value used to drive the analog portion of sensor 12 | 00h           | <a href="#">Page 94</a> |
| BDh              | R   | Sensor 13 Calibration | Stores the high byte of the 10-bit value used to drive the analog portion of sensor 13 | 00h           | <a href="#">Page 94</a> |
| BEh              | R   | Sensor 14 Calibration | Stores the high byte of the 10-bit value used to drive the analog portion of sensor 14 | 00h           | <a href="#">Page 94</a> |
| FDh              | R   | Product ID            | Stores a fixed value that identifies each product                                      | 3Ah           | <a href="#">Page 95</a> |
| FEh              | R   | Manufacturer ID       | Stores a fixed value that identifies SMSC  | 5Dh           | <a href="#">Page 45</a> |
| FFh              | R   | Revision              | Stores a fixed value that represents the revision number                               | 80h           | <a href="#">Page 95</a> |

During Power-On-Reset (POR), the default values are stored in the registers. A POR is initiated when power is first applied to the part and the voltage on the VDD supply surpasses the POR level as specified in the electrical characteristics. Any reads to undefined registers will return 00h. Writes to undefined registers will not have an effect.

When a bit is “set”, this means that the user writes a logic ‘1’ to it. When a bit is “cleared”, this means that the user writes a logic ‘0’ to it.



## 6.1 Main Status Control Register

Table 6.2 Main Status Control Register

| ADDR | R/W | REGISTER            | B7 | B6    | B5    | B4     | B3 | B2 | B1      | B0  | DEFAULT |
|------|-----|---------------------|----|-------|-------|--------|----|----|---------|-----|---------|
| 00h  | R/W | Main Status Control | -  | DEACT | SLEEP | DSLEEP | -  | -  | PWR_LED | INT | 00h     |

The Main Status and Control Register controls the primary power state of the device.

Bit 6 - DEACT - Deactivates all sensor scanning and LED activity.

- '0' - (default) - Sensor scanning is active and LEDs are functional.
- '1' - All sensor scanning is disabled and all linked LEDs are disabled (see [Section](#) ). The only way to restart scanning is to clear this bit. The status registers are automatically cleared and the INT bit is cleared.

Bit 5 - SLEEP - Enables Sleep state by deactivating the LED activity and scanning those sensors enabled via the Sleep Control register.

- '0' (default) - Sensor scanning is active and LEDs are functional.
- '1' - All LEDs are disabled (except LED11) and the Capacitive Touch Sensor scanning is limited to the sensors set in the Sleep Channel Control register (see [Section 6.22](#)). The status registers will not be cleared.

Bit 4 - DSLEEP - Enables the Deep Sleep state by deactivating all functions.

- '0' (default) - Sensor scanning is active and LEDs are functional.
- '1' - All sensor scanning is disabled. Except for LED11, all LEDs are driven to their programmed non-actuated state and no PWM operations will be done. The device will return to its previous power state when the ALERT pin is driven to its active level (see [Section 5.7](#)). The status registers are automatically cleared and the INT bit is cleared. SMBus communications targeted at the CAP1114 will bring the device out of deep sleep and automatically clear this bit.

Bit 1 - PWR\_LED - Controls the output of LED11 based on the state of bits 5 and 4.

- '0' (default) - The LED11 output is in the "inactive" or off state.
- '1' - The LED11 output is active in one of the following conditions:
  - a. Both bits 4 and 5 are set to a logic '0'. The LED will behave as defined by the LED11\_CTL bits (see [Section](#) ).
  - b. Either bit 4 or bit 5 is set to a logic '1'. The LED will behave as defined by the LED11\_ALT bits (see [Section](#) ).

Bit 0 - INT - Indicates that there is an interrupt. This bit is only set if the ALERT pin has been asserted. If a channel detects a press and its associated interrupt enable bit is set to a logic '0', no action is taken.

This bit is cleared by writing a logic '0' to it. When this bit is cleared, the ALERT pin will be deasserted and all status registers will be cleared if the condition has been removed.

- '0' - No interrupt pending.
- '1' - A button press has been detected on one or more channels and the interrupt has been asserted.

## 6.2 Button Status Registers

Table 6.3 Button Status Registers

| ADDR | R/W | REGISTER        | B7   | B6   | B5   | B4   | B3   | B2  | B1  | B0  | DEFAULT |
|------|-----|-----------------|------|------|------|------|------|-----|-----|-----|---------|
| 03h  | R   | Button Status 1 | UP   | DOWN | CS6  | CS5  | CS4  | CS3 | CS2 | CS1 | 00h     |
| 04h  | R   | Button Status 2 | CS14 | CS13 | CS12 | CS11 | CS10 | CS9 | CS8 | CS7 | 00h     |

The Button Status Registers store status bits that indicate a button press has been detected. A value of '0' in any bit indicates that no button press has been detected. A value of '1' in any bit indicates that a button press has been detected.

All status bits are cleared when the device enters the Deep Sleep or Inactive states (DSLEEP = '1' or DEACT = '1' - see [Section 6.1](#)). All status bits are cleared when the INT bit is cleared and if a touch on the respective Capacitive Touch Sensor is no longer present. If a touch is still detected, the bits will not be cleared (but this will not cause the interrupt to be asserted - see [Section 6.14](#))

**APPLICATION NOTE:** When the Button Status 1 Register is read, the Group Status register will be automatically cleared. Therefore, the Group Status register should be read prior to reading the Button Status Registers

### 6.2.1 Button Status 1

Bit 7 - UP - Indicates that a slide was detected on increasing sensors (i.e. Sensor 8 -> Sensor 9 -> Sensor 10). This bit is also set if a press is detected on the "Up" portion of the slider. If the Group auto-repeat is enabled, the ALERT pin will be periodically asserted while a slide or press and hold event is still detected. This bit is sticky and will remain set until cleared. Once cleared, it will be re-set when another interrupt is generated in the "UP" direction. This bit is automatically cleared if the DOWN bit is set.

Bit 6 - DOWN - Indicates that a slide was detected on decreasing sensors (i.e. Sensor 14 -> Sensor 13-> Sensor 12). This bit is also set if a press is detected on the "Down" portion of the slider. If the Group auto-repeat is enabled, the ALERT pin will be periodically asserted while a slide or press and hold event is still detected. This bit is sticky and will remain set until cleared. Once cleared, it will be re-set when another interrupt is generated in the "DOWN" direction. This bit is automatically cleared if the UP bit is set.

Bit 5 - CS6 - Indicates that a press was detected on Sensor 6. This sensor can be linked to LED6.

- '0' - A touch was not detected on the corresponding button.
- '1' - A touch was detected on the corresponding button.

Bit 4 - CS5 - Indicates that a press was detected on Sensor 5. This sensor can be linked to LED5.

Bit 3 - CS4 - Indicates that a press was detected on Sensor 4. This sensor can be linked to LED4.

Bit 2 - CS3 - Indicates that a press was detected on Sensor 3. This sensor can be linked to LED3

Bit 1 - CS2 - Indicates that a press was detected on Sensor 2. This sensor can be linked to LED2.

Bit 0 - CS1 - Indicates that a press was detected on Sensor 1. This sensor can be linked to LED1.

## 6.2.2 Button Status 2

Bit 7 - CS14 - Indicates that press was detected on Sensor 14. This sensor is part of the group which can be linked to LED9 and LED10.

Bit 6 - CS13 - Indicates that press was detected on Sensor 13. This sensor is part of the group which can be linked to LED9 and LED10.

Bit 5 - CS12 - Indicates that press was detected on Sensor 12. This sensor is part of the group which can be linked to LED9 and LED10.

Bit 4 - CS11 - Indicates that press was detected on Sensor 11. This sensor is part of the group which can be linked to LED9 and LED10.

Bit 3 - CS10 - Indicates that press was detected on Sensor 10. This sensor is part of the group which can be linked to LED9 and LED10.

Bit 2 - CS9 - Indicates that press was detected on Sensor 9. This sensor is part of the group which can be linked to LED9 and LED10.

Bit 1 - CS8 - Indicates that press was detected on Sensor 8. This sensor is part of the group which can be linked to LED9 and LED10.

Bit 0 - CS7 - Indicates that a press was detected on Sensor 7. This sensor can be linked to LED7.

## 6.3 Build Revision Register

Table 6.4 Build Revision Register

| ADDR | R/W | REGISTER       | B7 | B6 | B5 | B4     | B3     | B2     | B1     | B0     | DEFAULT |
|------|-----|----------------|----|----|----|--------|--------|--------|--------|--------|---------|
| 05h  | R   | Build Revision | -  | -  | -  | Build4 | Build3 | Build2 | Build1 | Build0 | 10h     |

The Build Revision Register indicates hardware defined settings that are used.

## 6.4 Slider Position / Volumetric Data Register

Table 6.5 Slider Position / Volumetric Data Register

| ADDR | R/W       | REGISTER                          | B7 | B6       | B5 | B4 | B3 | B2 | B1 | B0  | DEFAULT |
|------|-----------|-----------------------------------|----|----------|----|----|----|----|----|-----|---------|
| 06h  | R-C / R/W | Slider Position / Volumetric Data | -  | POS[6:0] |    |    |    |    |    | 00h |         |

The Slider Position / Volumetric Data Register indicates the absolute position of a Tap, Slide, or Press and Hold event detected on the Grouped sensors (slider). Alternately, the register stores volumetric data that increases or decreased based on detected operations on the Grouped sensors (slider).

**APPLICATION NOTE:** When the device enters the Deep Sleep state, the Slider Position / Volumetric Data Register (06h) is cleared.

Bits 6-0 - POS[6:0] - Indicate absolute position or volumetric data as determined by the POS\_VOL bit (see [Section 6.14](#)).

## Datasheet

### 6.4.1 Absolute Position

The absolute position of a single touch is available from this register. By interpolating information from up to 3 adjacent buttons, 16 different positions are calculated by the CAP1114 from the center of one button to the center of each adjacent button. The bits will encode a range from 2 to 98 indicative of where the touch occurred. [Table 6.6](#) shows an example of the settings assuming a single button is pressed.

If a slide is detected on the Grouped sensors, the POS[6:0] bits will indicate the most recently touched sensor (i.e. where the slide ended) however will not indicate where the slide originated.

**APPLICATION NOTE:** The register will be cleared to a value of 00h when it is read. It will be set to a valid position when the next ALERT is generated. It will be updated at the respective repeat rate for a slide or press and hold event regardless of whether it has been read or not. Therefore, it will only show the position of the last touch detected at the time of the interrupt.

**Table 6.6 Example Slider Absolute Position Decode**

| TOUCH POSITION | POS[6:0] SETTINGS |
|----------------|-------------------|
| CS8            | 02h (2d)          |
| CS9            | 12h (18d)         |
| CS10           | 22h (34d)         |
| CS11           | 32h (50d)         |
| CS12           | 42h (68d)         |
| CS13           | 52h (82d)         |
| CS14           | 62h (98d)         |

### 6.4.2 Volumetric Data

If they are setup to present Volumetric Data (see [Section 6.14](#)), the bits will encode a range from 0 to 100. This value is updated based on the Grouped sensor activity:

- A slide in the “UP” direction will increase the volumetric data by the Volumetric Step setting (see [Section 6.6](#)) whenever an interrupt is generated (including extra interrupts generated after the slide is complete).
- A slide in the “DOWN” direction will decrease the volumetric data by the Volumetric Step setting (see [Section 6.6](#)) whenever an interrupt is generated (including extra interrupts generated after the slide is complete)
- A tap (see [Section 5.5.1](#)) on the “UP” side will increase the volumetric data by a value of 1.
- A tap on the “DOWN” side will decrease the volumetric data by a value of 1.
- A press and hold (see [Section 5.5.2](#)) on the “UP” side will increase the volumetric data by a value of 1 at every repeat rate interval.
- A press and hold (see [Section 5.5.2](#)) on the “DOWN” side will decrease the volumetric data by a value of 1 at every repeat rate interval.

The bits are read / write.

## 6.5 Vendor ID Register

Table 6.7 Vendor ID Register

| ADDR | R/W | REGISTER  | B7 | B6 | B5 | B4 | B3 | B2 | B1 | B0 | DEFAULT |
|------|-----|-----------|----|----|----|----|----|----|----|----|---------|
| 08h  | R   | Vendor ID | 0  | 1  | 0  | 1  | 1  | 1  | 0  | 1  | 5Dh     |
| FEh  |     |           |    |    |    |    |    |    |    |    |         |

The Vendor ID Register stores an 8-bit value that represents SMSC.

## 6.6 Volumetric Step Register

Table 6.8 Volumetric Step Register

| ADDR | R/W | REGISTER        | B7 | B6 | B5 | B4 | B3            | B2 | B1 | B0  | DEFAULT |
|------|-----|-----------------|----|----|----|----|---------------|----|----|-----|---------|
| 09h  | R/W | Volumetric Step | -  | -  | -  | -  | VOL_STEP[3:0] |    |    | 01h |         |

The Volumetric Step Register controls the size of a step to the volumetric data when a slide is detected in the UP and DOWN directions.

Bits 3 - 0 - VOL\_STEP[3:0] - Determines the volumetric data step when a slide is detected. Each LSB corresponds to a value of  $\pm 1$ .

## 6.7 Noise Status Registers

Table 6.9 Noise Status Registers

| ADDR | R/W | REGISTER       | B7          | B6        | B5        | B4        | B3        | B2        | B1       | B0       | DEFAULT |
|------|-----|----------------|-------------|-----------|-----------|-----------|-----------|-----------|----------|----------|---------|
| 0Ah  | R   | Noise Status 1 | S1_RF_NOISE | S7_NOISE  | S6_NOISE  | S5_NOISE  | S4_NOISE  | S3_NOISE  | S2_NOISE | S1_NOISE | 00h     |
| 0Bh  | R   | Noise Status 2 | -           | S14_NOISE | S13_NOISE | S12_NOISE | S11_NOISE | S10_NOISE | S9_NOISE | S8_NOISE | 00h     |

The Noise Status Registers store status bits that are generated from the analog block if the detected noise is above the operating region of the analog detector. These bits indicate that the most recently received data from the sensor is invalid and should not be used for touch detection. Furthermore, so long as the bit is set for a particular channel, no decisions are made with the data. The queues are not updated, a touch is not detected, and a release is not detected.

These bits will also be set if RF noise is detected on any individual sensor. With the exception of CS1, these conditions are OR'd together when setting the bits. For CS1, the S1\_RF\_NOISE bit will be set when RF noise is detected, and the S1\_NOISE bit will be set if the detected noise is above the operating region of the detector.

These bits are not sticky and will be cleared automatically if the analog block does not report a noise error.

**Datasheet**

**APPLICATION NOTE:** For the CAP1114-2, if the lid closure detection circuitry is enabled, these bits count as sensors above the lid closure count threshold even if the corresponding data count is not. If the corresponding data byte exceeds the lid closure threshold, it is not counted twice.

**APPLICATION NOTE:** Regardless of the state of the Noise Status bits, if low frequency noise is detected on a sensor, that sample will be discarded unless the BLK\_ANA\_NOISE bit is set. As well, if RF noise is detected on a sensor, that sample will be discarded unless the BLK\_RF\_NOISE bit is set.

## 6.8 Lid Closure Status Registers

**Table 6.10 Lid Closure Status Registers**

| ADDR | R/W | REGISTER             | B7 | B6          | B5          | B4          | B3          | B2          | B1         | B0         | DEFAULT |
|------|-----|----------------------|----|-------------|-------------|-------------|-------------|-------------|------------|------------|---------|
| 0Ch  | R   | Lid Closure Status 1 | -  | S7_<br>LID  | S6_<br>LID  | S5_<br>LID  | S4_<br>LID  | S3_<br>LID  | S2_<br>LID | S1_<br>LID | 00h     |
| 0Dh  | R   | Lid Closure Status 2 | -  | S14_<br>LID | S13_<br>LID | S12_<br>LID | S11_<br>LID | S10_<br>LID | S9_<br>LID | S8_<br>LID | 00h     |

The Lid Closure Status Registers bits are only set if the lid closure detection circuitry is enabled (see [Section 6.24](#)). These status bits indicate that the corresponding Capacitive Touch Sensor exceeded the Lid Closure threshold. These bits will be set if a button press is detected because the Lid Closure threshold is a percentage of the Sensor Threshold.

These bits are used in combination with the Lid Closure Pattern register settings to determine when a Lid Closure Event is flagged (see [Section 6.26](#)).

These bits are not sticky and will be cleared automatically when the corresponding sensor count drops below the lid closure count threshold. The device does not flag a sensor as above or below the threshold until it has cycled through the queue (see [Section 6.25, "Lid Closure Queue Control Register"](#)).

**APPLICATION NOTE:** It is likely that recalibration will occur while the lid is closed, resulting in negative delta counts until recalibration takes place.

## 6.9 GPIO Status Register

**Table 6.11 GPIO Status Register**

| ADDR | R/W | REGISTER    | B7            | B6            | B5            | B4            | B3            | B2            | B1            | B0            | DEFAULT |
|------|-----|-------------|---------------|---------------|---------------|---------------|---------------|---------------|---------------|---------------|---------|
| 0Eh  | R-C | GPIO Status | GPIO8_<br>STS | GPIO7_<br>STS | GPIO6_<br>STS | GPIO5_<br>STS | GPIO4_<br>STS | GPIO3_<br>STS | GPIO2_<br>STS | GPIO1_<br>STS | 00h     |

The GPIO Status Register bits are set whenever one of the GPIO inputs changes states. If the LEDx / GPIOx pin is not configured as a GPIO or as an input, the respective bit will be set to a logic '0'.

The bits are cleared when the register is read.

## 6.10 Group Status Register

Table 6.12 Group Status Register

| ADDR | R/W | REGISTER     | B7  | B6   | B5    | B4 | B3 | B2   | B1  | B0 | DEFAULT |
|------|-----|--------------|-----|------|-------|----|----|------|-----|----|---------|
| 0Fh  | R-C | Group Status | LID | MULT | RESET | -  | UP | DOWN | TAP | PH | 00h     |

The Group Status Register indicates that one or more actions were detected on the Grouped sensors. The detectable actions are described in [Section 5.5](#) and [Section 5.6](#).

Bit 7 - LID - Indicates that a Lid Closure Event has been detected. This bit is sticky. When it is set, it will remain set until read. When a Lid Closure Event is detected, all new touches will be blocked.

Bit 6 - MULT - This bit is asserted if one or more touches are being blocked because greater than N buttons are simultaneously pressed.

Bit 5 - RESET - Indicates that the device has exited the reset state. This bit may be set via a power on reset or upon release of the RESET pin. When it is set, it will remain set until read.

Bit 3 - UP - Indicates that a slide was detected on increasing sensors (i.e. Sensor 8 -> Sensor 9 -> Sensor 10) or on CS14 when the Grouped sensors are ungrouped. This bit is also set if a touch (tap or press and hold event) is detected on the “Up” portion of the slider. If the Group auto-repeat is enabled, the ALERT pin will be periodically asserted while a slide or press and hold event is detected. This bit will be cleared when read and re-set when another interrupt is generated. This bit is cleared automatically if the DOWN bit is set.

Bit 2 - DOWN - Indicates that a slide was detected on decreasing sensors (i.e. Sensor 14 -> Sensor 13 -> Sensor 12) or on CS8 when the Grouped sensors are ungrouped. This bit is also set if a touch (tap or press and hold event) is detected on the “Down” portion of the slider. If the Group auto-repeat is enabled, the ALERT pin will be periodically asserted while a slide or press and hold event is detected. This bit will be cleared when read and re-set when another interrupt is generated. This bit is automatically cleared if the UP bit is set.

Bit 1 - TAP - Indicates that a tap was detected on one of the sensors within the Group. The relative position of the tap is indicated by the UP and DOWN bits so that a tap on the “UP” side of the group will assert the UP bit as well as the TAP bit. If the tap event is detected in the “center” of the slider that is neither “UP” nor “DOWN”, the bit will be set; however, no interrupt will be generated. This bit is sticky and will remain set until read.

Bit 0 - PH - Indicates that a press and hold event was detected on one of the sensors within the Group. the relative position of the press is indicated by the UP and DOWN bits so a touch and hold on the “UP” side of the group will assert the UP bit as well as the PH bit. If the press and hold event is detected in the “center” of the slider that is neither “UP” nor “DOWN”, the bit will be set; however, no interrupt will be generated. This bit is sticky and will remain set until read. If the condition is still present, this bit will be re-set when the interrupt is generated.

## 6.11 Sensor Delta Count Registers

Table 6.13 Sensor Delta Count Registers

| ADDR | R/W | REGISTER             | B7   | B6 | B5 | B4 | B3 | B2 | B1 | B0 | DEFAULT |
|------|-----|----------------------|------|----|----|----|----|----|----|----|---------|
| 10h  | R   | Sensor 1 Delta Count | Sign | 64 | 32 | 16 | 8  | 4  | 2  | 1  | 00h     |
| 11h  | R   | Sensor 2 Delta Count | Sign | 64 | 32 | 16 | 8  | 4  | 2  | 1  | 00h     |

Table 6.13 Sensor Delta Count Registers (continued)

| ADDR | R/W | REGISTER              | B7   | B6 | B5 | B4 | B3 | B2 | B1 | B0 | DEFAULT |
|------|-----|-----------------------|------|----|----|----|----|----|----|----|---------|
| 12h  | R   | Sensor 3 Delta Count  | Sign | 64 | 32 | 16 | 8  | 4  | 2  | 1  | 00h     |
| 13h  | R   | Sensor 4 Delta Count  | Sign | 64 | 32 | 16 | 8  | 4  | 2  | 1  | 00h     |
| 14h  | R   | Sensor 5 Delta Count  | Sign | 64 | 32 | 16 | 8  | 4  | 2  | 1  | 00h     |
| 15h  | R   | Sensor 6 Delta Count  | Sign | 64 | 32 | 16 | 8  | 4  | 2  | 1  | 00h     |
| 16h  | R   | Sensor 7 Delta Count  | Sign | 64 | 32 | 16 | 8  | 4  | 2  | 1  | 00h     |
| 17h  | R   | Sensor 8 Delta Count  | Sign | 64 | 32 | 16 | 8  | 4  | 2  | 1  | 00h     |
| 18h  | R   | Sensor 9 Delta Count  | Sign | 64 | 32 | 16 | 8  | 4  | 2  | 1  | 00h     |
| 19h  | R   | Sensor 10 Delta Count | Sign | 64 | 32 | 16 | 8  | 4  | 2  | 1  | 00h     |
| 1Ah  | R   | Sensor 11 Delta Count | Sign | 64 | 32 | 16 | 8  | 4  | 2  | 1  | 00h     |
| 1Bh  | R   | Sensor 12 Delta Count | Sign | 64 | 32 | 16 | 8  | 4  | 2  | 1  | 00h     |
| 1Ch  | R   | Sensor 13 Delta Count | Sign | 64 | 32 | 16 | 8  | 4  | 2  | 1  | 00h     |
| 1Dh  | R   | Sensor 14 Delta Count | Sign | 64 | 32 | 16 | 8  | 4  | 2  | 1  | 00h     |

The Sensor Delta Count Registers store the delta count that is compared against the threshold used to determine if a touch has been detected. The count value represents a change in input due to the capacitance associated with a touch on one of the sensors and is referenced to a calibrated base “Not touched” count value. The delta is an instantaneous change and is updated once per sensor per sensing cycle (see [Section 5.4.4](#) - sensor cycle).

The value presented is a standard 2’s complement number. In addition, the value is capped at a value of 7Fh. A reading of 7Fh indicates that the sensitivity settings are too high and should be adjusted accordingly (see [Section 6.13](#)).

The value is also capped at a negative value of FFh for negative delta counts which may result upon a release.

## 6.12 Queue Control Register

Table 6.14 Queue Control Register

| ADDR | R/W | REGISTER             | B7 | B6 | B5 | B4 | B3 | B2           | B1 | B0 | DEFAULT |
|------|-----|----------------------|----|----|----|----|----|--------------|----|----|---------|
| 1Eh  | R/W | Button Queue Control | -  | -  | -  | -  | -  | QUEUE_B[2:0] |    |    | 03h     |



The Queue Control Register determines the number of consecutive samples for which a single sensor output is above the Sensor Threshold before a touch is detected. This is also used to determine the number of consecutive samples used to detect a button release. The queue applies independently to all channels.

Bits 2 - 0 - QUEUE\_B[2:0] - The number of consecutive samples necessary to detect a touch. Default is 3 consecutive samples. See [Table 6.15](#).

**Table 6.15 QUEUE\_B Bit Decode**

| QUEUE_B[2:0] |   |   | NUMBER OF CONSECUTIVE READINGS > THRESHOLD |
|--------------|---|---|--|
| 2            | 1 | 0 |  |
| 0            | 0 | 0 | 1  |
| 0            | 0 | 1 | 1  |
| 0            | 1 | 0 | 2  |
| 0            | 1 | 1 | 3 (default)                                |
| 1            | 0 | 0 | 4  |
| 1            | 0 | 1 | 5  |
| 1            | 1 | 0 | 6  |
| 1            | 1 | 1 | 7  |

## 6.13 Data Sensitivity Registers

**Table 6.16 Data Sensitivity Register**

| ADDR | R/W | REGISTER         | B7 | B6               | B5 | B4 | B3              | B2 | B1 | B0 | DEFAULT |
|------|-----|------------------|----|------------------|----|----|-----------------|----|----|----|---------|
| 1Fh  | R/W | Data Sensitivity | -  | DELTA_SENSE[2:0] |    |    | BASE_SHIFT[3:0] |    |    |    | 2Fh     |

The Data Sensitivity Register controls the sensitivity of all button channels.

Bits 6- 4 DELTA\_SENSE[2:0] - Controls the sensitivity of a touch detection. The sensitivity settings act to scale the relative delta count value higher or lower based on the system parameters. A setting of 000b is the most sensitive while a setting of 111b is the least sensitive (see [Table 6.17](#)). At the more sensitive settings, touches are detected for a smaller delta C corresponding to a "lighter" touch. These settings are more sensitive to noise and a noisy environment may flag more false touches than higher sensitivity levels.

**APPLICATION NOTE:** A value of 128x is the most sensitive setting available. At the most sensitive settings, the MSB of the Delta Count register represents 64 out of ~25,000 which corresponds to a touch of approximately 0.25% of the base capacitance (or a  $\Delta C$  of 25fF from a 10pF base capacitance). Conversely, a value of 1x is the least sensitive setting available. At these settings, the MSB of the Delta Count register corresponds to a delta count of 8192 counts out of ~25,000 which corresponds to a touch of approximately 33% of the base capacitance (or a  $\Delta C$  of 3.33pF from a 10pF base capacitance).

Table 6.17 DELTA\_SENSE Bit Decode

| DELTA_SENSE[2:0] |   |   | SENSITIVITY MULTIPLIER |
|------------------|---|---|------------------------|
| 2                | 1 | 0 |                        |
| 0                | 0 | 0 | 128x (most sensitive)  |
| 0                | 0 | 1 | 64x                    |
| 0                | 1 | 0 | 32x (default)          |
| 0                | 1 | 1 | 16x                    |
| 1                | 0 | 0 | 8x                     |
| 1                | 0 | 1 | 4x                     |
| 1                | 1 | 0 | 2x                     |
| 1                | 1 | 1 | 1x - (least sensitive) |

Bits 3 - 0 - BASE\_SHIFT [3:0] - Controls the scaling and data presentation of the Base Count registers. The higher the value of these bits, the larger the range and the lower the resolution of the data presented. The scale factor represents the multiplier to the bit-weighting presented in these register descriptions. See [Table 6.18](#).

**APPLICATION NOTE:** The BASE\_SHIFT[3:0] bits normally do not need to be updated. These settings will not affect touch detection or sensitivity. These bits are sometimes helpful in analyzing the Cap Sensing board performance and stability.

Table 6.18 BASE\_SHIFT Bit Decode

| BASE_SHIFT[3:0] |   |   |   | DATA SCALING FACTOR       |
|-----------------|---|---|---|---------------------------|
| 3               | 2 | 1 | 0 |                           |
| 0               | 0 | 0 | 0 | 1x                        |
| 0               | 0 | 0 | 1 | 2x                        |
| 0               | 0 | 1 | 0 | 4x                        |
| 0               | 0 | 1 | 1 | 8x                        |
| 0               | 1 | 0 | 0 | 16x                       |
| 0               | 1 | 0 | 1 | 32x                       |
| 0               | 1 | 1 | 0 | 64x                       |
| 0               | 1 | 1 | 1 | 128x                      |
| 1               | 0 | 0 | 0 | 256x                      |
| All others      |   |   |   | 256x<br>(default = 1111b) |

## 6.14 Configuration Register

Table 6.19 Configuration Register

| ADDR | R/W | REGISTER      | B7          | B6          | B5                    | B4                    | B3                   | B2           | B1                   | B0           | DEFAULT |
|------|-----|---------------|-------------|-------------|-----------------------|-----------------------|----------------------|--------------|----------------------|--------------|---------|
| 20h  | R/W | Configuration | TIME<br>OUT | POS_<br>VOL | BLK_<br>DIG_<br>NOISE | BLK_<br>ANA_<br>NOISE | MAX_<br>DUR_<br>EN_B | RPT_<br>EN_B | MAX_<br>DUR_<br>EN_G | RPT_<br>EN_G | 29h     |

The Configuration Register controls general global functionality that affects the entire device.

Bit 7 - TIMEOUT - Enables the timeout and idle functionality of the SMBus protocol.

- '0' (default) - The SMBus timeout and idle functionality are disabled. The SMBus interface will not time out if the clock line is held low. Likewise, it will not reset if both the data and clock lines are held high for longer than 150us. This is used for I<sup>2</sup>C compliance.
- '1' - The SMBus timeout and idle functionality are enabled. The SMBus interface will time out if the clock line is held low for longer than 30ms. Likewise, it will reset if both the data and clock lines are held high for longer than 150us.

**APPLICATION NOTE:** The idle timeout does not apply to the Deep Sleep state. When the CAP1114 is operating in Deep Sleep, if the host communicates with a device other than the CAP1114 and no stop bit is set, the CAP1114 will not reset the protocol and, therefore, will not respond to communications until a stop bit is sent.

Bit 6 - POS\_VOL - Determines the behavior of the POS[6:0] status bits when a Grouped sensor is activated - see [Section 6.4](#).

- '0' (default) - The POS[6:0] bits represent position information that indicates which sensor was touched or the last sensor touched during a slide.
- '1' - The POS[6:0] bits represent volumetric data. The Position / Volumetric Data register is read / write.

Bit 5 - BLK\_DIG\_NOISE - Determines whether the noise threshold is checked when determining whether to discard samples.

- '0' - The noise threshold is enabled and checked. If a sample is above the noise threshold, it is not included in the re-calibration routine.
- '1' (default) - The noise threshold is disabled. No samples are excluded from the re-calibration routine.

Bit 4 - BLK\_ANA\_NOISE - Determines whether the noise flag setting will block a touch detection as well as the analog calibration routine.

- '0' (default) If noise is detected on the low frequency noise detector, a touch is blocked on the corresponding channel and will force the analog calibration routine to retry. Note that this does not require the Noise Status register bits to be set.
- '1' - A touch is not blocked if low frequency noise is detected. Likewise, the analog calibration routine will not retry if the analog noise bit is set.

Bit 3 - MAX\_DUR\_EN\_B - Determines whether the maximum duration recalibration is enabled for non-grouped sensors.

- '0' - The maximum duration recalibration functionality is disabled. A press may be held indefinitely and no re-calibration will be performed on any button.
- '1' (default) - The maximum duration recalibration functionality is enabled. If a press is held for longer than the MAX\_DUR\_B bit settings, the re-calibration routine will be restarted (see [Section 6.16](#)).

**Datasheet**

Bit 2 - RPT\_EN\_B - Determines whether repeat rate is enabled for all buttons.

- '0' (default) - Repeat rate is not enabled. An interrupt will be generated when a touch is detected.
- '1' - Repeat rate is enabled for all buttons.

Bit 1 - MAX\_DUR\_EN\_G - Determines whether the maximum duration recalibration is enabled for grouped sensors.

- '0' (default) - The maximum duration recalibration functionality is disabled. A press may be held indefinitely and no re-calibration will be performed on any button.
- '1' - The maximum duration recalibration functionality is enabled. If a press is held for longer than the MAX\_DUR\_G bit settings, the re-calibration routine will be restarted (see [Section 6.18](#)).

Bit 0 - RPT\_EN\_G - Determines the interrupt mechanism used when a Press and Hold event is detected on a grouped sensor.

- '0' - An interrupt will be generated when a Press and Hold event is detected.
- '1' (default) - An interrupt will be generated when a Press and Hold event is detected and at the programmed repeat rate so long as the sensor is pressed.

## 6.15 Sensor Enable Register

**Table 6.20 Sensor Enable Register**

| ADDR | R/W | REGISTER      | B7    | B6    | B5    | B4    | B3    | B2    | B1    | B0    | DEFAULT |
|------|-----|---------------|-------|-------|-------|-------|-------|-------|-------|-------|---------|
| 21h  | R/W | Sensor Enable | GP_EN | S7_EN | S6_EN | S5_EN | S4_EN | S3_EN | S2_EN | S1_EN | FFh     |

The Sensor Enable Register determines whether a Capacitive Touch Sensor input is included in the sampling cycle in the fully active state. The length of the sampling cycle is not affected by the number of sensors measured.

Bit 7 - GP\_EN - Enables the Grouped Sensors to be included during the sampling cycle.

- '0' - All sensors in the grouped sensors will not be sampled regardless of the state of the VOL\_UP\_DOWN bit.
- '1' (default) - Grouped sensors will be sampled. Individual channels are enabled via the Group Sampling Enable register.

Bit 6 - S7\_EN - Enables the CS7 input to be included during the sampling cycle.

- '0' - The CS7 input is not included in the sampling cycle.
- '1' (default) - The CS7 input is included in the sampling cycle.

Bit 5 - S6\_EN - Enables the CS6 input to be included during the sampling cycle.

Bit 4 - S5\_EN - Enables the CS5 input to be included during the sampling cycle.

Bit 3 - S4\_EN - Enables the CS4 input to be included during the sampling cycle.

Bit 2 - S3\_EN - Enables the CS3 input to be included during the sampling cycle.

Bit 1 - S2\_EN - Enables the CS2 input to be included during the sampling cycle.

Bit 0 - S1\_EN - Enables the CS1 input to be included during the sampling cycle.

## 6.16 Button Configuration Register

Table 6.21 Button Configuration Register

| ADDR | R/W | REGISTER             | B7             | B6 | B5 | B4 | B3              | B2 | B1 | B0 | DEFAULT |
|------|-----|----------------------|----------------|----|----|----|-----------------|----|----|----|---------|
| 22h  | R/W | Button Configuration | MAX_DUR_B[3:0] |    |    |    | RPT_RATE_B[3:0] |    |    |    | A4h     |

The Button Configuration Register controls timings associated with the Capacitive Sensor channels 1 - 7 that are not Grouped.

Bits 7 - 4 - MAX\_DUR\_B [3:0] - (default 1010b) - Determines the maximum time that a button is allowed to be pressed until the Capacitive Touch sensor is recalibrated as shown in [Table 6.22](#).

Bits 3 - 0 - RPT\_RATE\_B[3:0] - (default 0100b) Determines the time duration between interrupt assertions when auto repeat is enabled. The resolution is 35ms the range is from 35ms to 560ms as shown in [Table 6.23](#).

Table 6.22 MAX\_DUR\_B and MAX\_DUR\_G Bit Decode

| MAX_DUR_B[3:0] AND MAX_DUR_G[3:0] |   |   |   | TIME BEFORE RECALIBRATION               |
|-----------------------------------|---|---|---|---|
| 3                                 | 2 | 1 | 0 |   |
| 0                                 | 0 | 0 | 0 | 560ms                                   |
| 0                                 | 0 | 0 | 1 | 840ms                                   |
| 0                                 | 0 | 1 | 0 | 1120ms                                  |
| 0                                 | 0 | 1 | 1 | 1400ms                                  |
| 0                                 | 1 | 0 | 0 | 1680ms                                  |
| 0                                 | 1 | 0 | 1 | 2240ms                                  |
| 0                                 | 1 | 1 | 0 | 2800ms                                  |
| 0                                 | 1 | 1 | 1 | 3360ms                                  |
| 1                                 | 0 | 0 | 0 | 3920ms                                  |
| 1                                 | 0 | 0 | 1 | 4480ms                                  |
| 1                                 | 0 | 1 | 0 | 5600ms<br>(default for CS1 - CS7)       |
| 1                                 | 0 | 1 | 1 | 6720ms                                  |
| 1                                 | 1 | 0 | 0 | 7840ms                                  |
| 1                                 | 1 | 0 | 1 | 8906ms<br>(default for Grouped Sensors) |
| 1                                 | 1 | 1 | 0 | 10080ms                                 |
| 1                                 | 1 | 1 | 1 | 11200ms                                 |

Table 6.23 RPT\_RATE\_B / SL / PH Bit Decode

| RPT_RATE_B / RPT_RATE_SL / RPT_RATE_PH |   |   |   | INTERRUPT REPEAT RATE |
|--|---|---|---|-----------------------|
| 3                                      | 2 | 1 | 0 |                       |
| 0                                      | 0 | 0 | 0 | 35ms                  |
| 0                                      | 0 | 0 | 1 | 70ms                  |
| 0                                      | 0 | 1 | 0 | 105ms                 |
| 0                                      | 0 | 1 | 1 | 140ms                 |
| 0                                      | 1 | 0 | 0 | 175ms (default)       |
| 0                                      | 1 | 0 | 1 | 210ms                 |
| 0                                      | 1 | 1 | 0 | 245ms                 |
| 0                                      | 1 | 1 | 1 | 280ms                 |
| 1                                      | 0 | 0 | 0 | 315ms                 |
| 1                                      | 0 | 0 | 1 | 350ms                 |
| 1                                      | 0 | 1 | 0 | 385ms                 |
| 1                                      | 0 | 1 | 1 | 420ms                 |
| 1                                      | 1 | 0 | 0 | 455ms                 |
| 1                                      | 1 | 0 | 1 | 490ms                 |
| 1                                      | 1 | 1 | 0 | 525ms                 |
| 1                                      | 1 | 1 | 1 | 560ms                 |

## 6.17 Group Configuration Register 1

Table 6.24 Group Configuration Register 1

| ADDR | R/W | REGISTER              | B7               | B6 | B5 | B4 | B3           | B2 | B1 | B0 | DEFAULT |
|------|-----|-----------------------|------------------|----|----|----|--------------|----|----|----|---------|
| 23h  | R/W | Group Configuration 1 | RPT_RATE_PH[3:0] |    |    |    | M_PRESS[3:0] |    |    |    | 47h     |

The Group Configuration 1 Register controls timings associated with the Capacitive Sensor channels 8 - 14 that are included in the group.

Bits 7-4 - RPT\_RATE\_PH[3:0] - (default 0100b) Determines the time duration between interrupt assertions when auto repeat is enabled. This setting applies when a press and hold condition is detected on the on the Grouped Sensors (see [Section 5.5](#)). The resolution is 35ms the range is from 35ms to 560ms as shown in [Table 6.23](#).

Bits 3- 0 - M\_PRESS[3:0] - (default 0111b) - Determines the minimum amount of time that a sensor in the Group must detect a button press to detect a Press and Hold event. If the sensor detects a touch for longer than the M\_PRESS[3:0] settings, a Press and Hold event is detected. This has no

effect on whether a slide is detected within the group. If a slide is detected before or after the press has been confirmed, it is treated as a separate event.

This is the maximum amount of time that a sensor in the Group can detect a button press to differentiate between a tap and a press and hold. If a sensor detects a touch for less than or equal to the M\_PRESS[3:0] settings, a Tap event is detected.

The resolution is 35ms the range is from 35ms to 560ms as shown in [Table 6.25](#).

**Table 6.25 M\_PRESS Bit Decode**

| M_PRESS[3:0] |   |   |   | M_PRESS TIME       |
|--------------|---|---|---|--------------------|
| 3            | 2 | 1 | 0 |                    |
| 0            | 0 | 0 | 0 | 35ms               |
| 0            | 0 | 0 | 1 | 70ms               |
| 0            | 0 | 1 | 0 | 105ms              |
| 0            | 0 | 1 | 1 | 140ms              |
| 0            | 1 | 0 | 0 | 175ms              |
| 0            | 1 | 0 | 1 | 210ms              |
| 0            | 1 | 1 | 0 | 245ms              |
| 0            | 1 | 1 | 1 | 280ms<br>(default) |
| 1            | 0 | 0 | 0 | 315ms              |
| 1            | 0 | 0 | 1 | 350ms              |
| 1            | 0 | 1 | 0 | 385ms              |
| 1            | 0 | 1 | 1 | 420ms              |
| 1            | 1 | 0 | 0 | 455ms              |
| 1            | 1 | 0 | 1 | 490ms              |
| 1            | 1 | 1 | 0 | 525ms              |
| 1            | 1 | 1 | 1 | 560ms              |

## 6.18 Group Configuration Register 2

**Table 6.26 Group Configuration Register 2**

| ADDR | R/W | REGISTER              | B7             | B6 | B5 | B4 | B3               | B2 | B1 | B0 | DEFAULT |
|------|-----|-----------------------|----------------|----|----|----|------------------|----|----|----|---------|
| 24h  | R/W | Group Configuration 2 | MAX_DUR_G[3:0] |    |    |    | RPT_RATE_SL[3:0] |    |    |    | D4h     |

The Group Configuration 2 Register controls timings associated with the Capacitive Sensor channels 8 - 14 that are included in the group.

## Datasheet

Bits 7 - 4 - MAX\_DUR\_G [3:0] - (default 1101b) - Determines the maximum time that a button is allowed to be pressed until the Capacitive Touch sensor is recalibrated as shown in [Table 6.22](#).

Bits 3 - 0 - RPT\_RATE\_SL[3:0] - (default 0100b) Determines the time duration between interrupt assertions when auto repeat is enabled. This setting applies when a slide is detected on the Grouped Sensors and acts as the base repeat rate that is adjusted based on the slide speed (see [Section 5.5.5](#)). The resolution is 35ms the range is from 35ms to 560ms as shown in [Table 6.23](#).

## 6.19 Calibration Enable Register

Table 6.27 Calibration Enable Register

| ADDR | R/W | REGISTER           | B7    | B6     | B5     | B4     | B3     | B2     | B1     | B0     | DEFAULT |
|------|-----|--------------------|-------|--------|--------|--------|--------|--------|--------|--------|---------|
| 25h  | R/W | Calibration Enable | G_CEN | S7_CEN | S6_CEN | S5_CEN | S4_CEN | S3_CEN | S2_CEN | S1_CEN | FFh     |

The Calibration Enable Register controls whether the indicated Capacitive Touch Sensor input is automatically re-calibrated. If a sensor is not enabled, the corresponding calibration enable bit is ignored.

Bit 7- G\_CEN - Enables all sensors in the group to be re-calibrated simultaneously.

- '0' - None of the grouped channels are automatically re-calibrated. They can be re-calibrated manually by setting the G\_CAL bit.
- '1' (default) - All of the grouped channels are automatically re-calibrated as the CAP1114 samples.

Bit 6 - S7\_CEN - Enables the CS7 input to be re-calibrated automatically.

- '0' - The CS7 input is not automatically re-calibrated.
- '1' (default) - The CS7 input is automatically re-calibrated as the CAP1114 samples.

Bit 5 - S6\_CEN - Enables the CS6 input to be re-calibrated automatically.

Bit 4 - S5\_CEN - Enables the CS5 input to be re-calibrated automatically.

Bit 3 - S4\_CEN - Enables the CS4 input to be re-calibrated automatically.

Bit 2 - S3\_CEN - Enables the CS3 input to be re-calibrated automatically.

Bit 1 - S2\_CEN - Enables the CS2 input to be re-calibrated automatically.

Bit 0 - S1\_CEN - Enables the CS1 input to be re-calibrated automatically.

## 6.20 Calibration Activate Registers

Table 6.28 Calibration Activate Registers

| ADDR | R/W | REGISTER                            | B7    | B6      | B5      | B4      | B3      | B2      | B1     | B0     | DEFAULT |
|------|-----|-------------------------------------|-------|---------|---------|---------|---------|---------|--------|--------|---------|
| 26h  | R/W | Calibration Activate                | G_CAL | S7_CAL  | S6_CAL  | S5_CAL  | S4_CAL  | S3_CAL  | S2_CAL | S1_CAL | 00h     |
| 46h  | R/W | Grouped Sensor Calibration Activate |       | S14_CAL | S13_CAL | S12_CAL | S11_CAL | S10_CAL | S9_CAL | S8_CAL | 00h     |



The Calibration Activate Registers force the respective sensors to be re-calibrated. When a bit is set, the corresponding Capacitive Touch Sensor will be re-calibrated and the bit will be automatically cleared once the re-calibration routine has finished. This calibration routine will update the internal analog controls and gain settings followed by a digital calibration to capture the base count for touch detection. During the re-calibration routine, the sensors will not detect a press for up to 600ms and the Sensor Base Count register values will be invalid. During this time, any press on the corresponding sensors will invalidate the re-calibration.

### 6.20.1 Calibration Activate - 26h

Bit 7 - G\_CAL - When set, all sensors in the group are re-calibrated. This bit is automatically cleared once all of the sensors in the group have been re-calibrated successfully.

Bit 6 - S7\_CAL - When set, the CS7 input is re-calibrated. This bit is automatically cleared once the sensor has been re-calibrated successfully.

Bit 5 - S6\_CAL - When set, the CS6 input is re-calibrated. This bit is automatically cleared once the sensor has been re-calibrated successfully.

Bit 4 - S5\_CAL - When set, the CS5 input is re-calibrated. This bit is automatically cleared once the sensor has been re-calibrated successfully.

Bit 3 - S4\_CAL - When set, the CS4 input is re-calibrated. This bit is automatically cleared once the sensor has been re-calibrated successfully.

Bit 2 - S3\_CAL - When set, the CS3 input is re-calibrated. This bit is automatically cleared once the sensor has been re-calibrated successfully.

Bit 1 - S2\_CAL - When set, the CS2 input is re-calibrated. This bit is automatically cleared once the sensor has been re-calibrated successfully.

Bit 0 - S1\_CAL - When set, the CS1 input is re-calibrated. This bit is automatically cleared once the sensor has been re-calibrated successfully.

### 6.20.2 Grouped Sensor Calibration Activate - 46h

Bit 6 - S14\_CAL - When set, the CS14 input is re-calibrated. This bit is automatically cleared once the sensor has been re-calibrated successfully.

Bit 5 - S13\_CAL - When set, the CS13 input is re-calibrated. This bit is automatically cleared once the sensor has been re-calibrated successfully.

Bit 4 - S12\_CAL - When set, the CS12 input is re-calibrated. This bit is automatically cleared once the sensor has been re-calibrated successfully.

Bit 3 - S11\_CAL - When set, the CS11 input is re-calibrated. This bit is automatically cleared once the sensor has been re-calibrated successfully.

Bit 2 - S10\_CAL - When set, the CS10 input is re-calibrated. This bit is automatically cleared once the sensor has been re-calibrated successfully.

Bit 1 - S9\_CAL - When set, the CS9 input is re-calibrated. This bit is automatically cleared once the sensor has been re-calibrated successfully.

Bit 0 - S8\_CAL - When set, the CS8 input is re-calibrated. This bit is automatically cleared once the sensor has been re-calibrated successfully.

## 6.21 Interrupt Enable Registers

Table 6.29 Interrupt Enable Registers

| ADDR | R/W | REGISTER           | B7           | B6           | B5           | B4           | B3           | B2           | B1           | B0           | DEFAULT |
|------|-----|--------------------|--------------|--------------|--------------|--------------|--------------|--------------|--------------|--------------|---------|
| 27h  | R/W | Interrupt Enable 1 | G_INT_EN     | S7_INT_EN    | S6_INT_EN    | S5_INT_EN    | S4_INT_EN    | S3_INT_EN    | S2_INT_EN    | S1_INT_EN    | FFh     |
| 28h  | R/W | Interrupt Enable 2 | GPIO8_INT_EN | GPIO7_INT_EN | GPIO6_INT_EN | GPIO5_INT_EN | GPIO4_INT_EN | GPIO3_INT_EN | GPIO2_INT_EN | GPIO1_INT_EN | 00h     |

The Interrupt Enable Registers determine whether a button press or GPIO input changing state causes the interrupt pin to be asserted.

### 6.21.1 Interrupt Enable 1

Bit 7 - G\_INT\_EN - Enables the interrupt pin to be asserted if a slide, tap, or press and hold action is detected on the grouped sensors.

- '0' - The interrupt pin will not be asserted if a slide, tap, or press and hold action is detected on the grouped sensors (associated with the UP, DOWN, TAP, and PH status bits).
- '1' (default) - The interrupt pin will be asserted if a slide, tap, or press and hold event is detected on the grouped sensors (associated with the UP, DOWN, TAP, and PH status bits).

Bit 6 - S7\_INT\_EN - Enables the interrupt pin to be asserted if a touch is detected on CS7 (associated with the CS7 status bit).

- '0' - The interrupt pin will not be asserted if a touch is detected on CS7 (associated with the CS7 status bit).
- '1' (default) - The interrupt pin will be asserted if a touch is detected on CS7 (associated with the CS7 status bit).

Bit 5 - S6\_INT\_EN - Enables the interrupt pin to be asserted if a touch is detected on CS6 (associated with the CS6 status bit).

Bit 4 - S5\_INT\_EN - Enables the interrupt pin to be asserted if a touch is detected on CS5 (associated with the CS5 status bit).

Bit 3 - S4\_INT\_EN - Enables the interrupt pin to be asserted if a touch is detected on CS4 (associated with the CS4 status bit).

Bit 2 - S3\_INT\_EN - Enables the interrupt pin to be asserted if a touch is detected on CS3 (associated with the CS3 status bit).

Bit 1 - S2\_INT\_EN - Enables the interrupt pin to be asserted if a touch is detected on CS2 (associated with the CS2 status bit).

Bit 0 - S1\_INT\_EN - Enables the interrupt pin to be asserted if a touch is detected on CS1 (associated with the CS1 status bit).

### 6.21.2 Interrupt Enable 2

These bits enable the interrupt pin to be asserted when the GPIOx status bit has been set.

Bit 7 - GPIO8\_INT\_EN - Enables the interrupt pin to be asserted if the GPIO8 status bit has been set.

- '0' (default) - The interrupt pin will not be asserted if the GPIO8 status bit has been set.
- '1' - The interrupt pin will be asserted if the GPIO8 status bit has been set.

Bit 6 - GPIO7\_INT\_EN - Enables the interrupt pin to be asserted if the GPIO7 status bit has been set.

Bit 5 - GPIO6\_INT\_EN - Enables the interrupt pin to be asserted if the GPIO6 status bit has been set.

Bit 4 - GPIO5\_INT\_EN - Enables the interrupt pin to be asserted if the GPIO5 status bit has been set.

Bit 3 - GPIO4\_INT\_EN - Enables the interrupt pin to be asserted if the GPIO4 status bit has been set.

Bit 2 - GPIO3\_INT\_EN - Enables the interrupt pin to be asserted if the GPIO3 status bit has been set.

Bit 1 - GPIO2\_INT\_EN - Enables the interrupt pin to be asserted if the GPIO2 status bit has been set.

Bit 0 - GPIO1\_INT\_EN - Enables the interrupt pin to be asserted if the GPIO1 status bit has been set.

## 6.22 Sleep Channel Control Register

Table 6.30 Sleep Channel Control Register

| ADDR | R/W | REGISTER              | B7       | B6       | B5       | B4       | B3       | B2       | B1       | B0       | DEFAULT |
|------|-----|-----------------------|----------|----------|----------|----------|----------|----------|----------|----------|---------|
| 29h  | R/W | Sleep Channel Control | GR_SLEEP | S7_SLEEP | S6_SLEEP | S5_SLEEP | S4_SLEEP | S3_SLEEP | S2_SLEEP | S1_SLEEP | 00h     |

The Sleep Channel Control Register determines which sensors are sampled when the device is placed into the Sleep state.

**APPLICATION NOTE:** If this register is updated while the device is in the Sleep state, the conversion cycle may be extended or for the first measurement of the new Capacitive Touch Sensors. It will correct itself on subsequent measurement cycles.

**APPLICATION NOTE:** If this register is updated while the device is in the Sleep state, it is recommended to force a recalibration routine on newly activated channels.

Bit 7 - GR\_SLEEP - Enables the Grouped sensors to be sampled when the device is placed into the Sleep state.

- '0' (default) - Grouped Sensors are not sampled when the device is in the Sleep state.
- '1' - The Grouped Sensors are sampled when the device is in Sleep mode. If a tap, slide, or touch and hold is detected, the appropriate status bit is set and an interrupt generated. Individual sensors will be enabled via the Group Sensor Enable register.

Bit 6 - S7\_SLEEP - Enables the CS7 sensor to be sampled when the device is placed into sleep mode.

- '0' (default) - The CS7 input is not sampled when the device is in the Sleep state
- '1' - The CS7 input is sampled when the device is in Sleep mode. If a touch is detected, the status bit is set and an interrupt generated.

Bit 5 - S6\_SLEEP - Enables the CS6 sensor to be sampled when the device is placed into the Sleep state.

Bit 4 - S5\_SLEEP - Enables the CS5 sensor to be sampled when the device is placed into the Sleep state.

Bit 3 - S4\_SLEEP - Enables the CS4 sensor to be sampled when the device is placed into the Sleep state.

Bit 2 - S3\_SLEEP - Enables the CS3 sensor to be sampled when the device is placed into the Sleep state.

Bit 1 - S2\_SLEEP - Enables the CS2 sensor to be sampled when the device is placed into the Sleep state.

## Datasheet

Bit 0 - S1\_SLEEP - Enables the CS1 sensor to be sampled when the device is placed into the Sleep state.

## 6.23 Multiple Touch Configuration Register

Table 6.31 Multiple Touch Configuration Register

| ADDR | R/W | REGISTER              | B7          | B6 | B5 | B4 | B3            | B2 | B1            | B0 | DEFAULT |
|------|-----|-----------------------|-------------|----|----|----|---------------|----|---------------|----|---------|
| 2Ah  | R/W | Multiple Touch Config | MULT_BLK_EN | -  | -  | -  | B_MULT_T[1:0] |    | G_MULT_T[1:0] |    | 82h     |

The Multiple Touch Configuration Register controls the settings for the multiple touch detection circuitry. These settings determine the number of sensors associated with this detection and the CAP1114 device behavior.

Bit 7 - MULT\_BLK\_EN - Enables the multiple button blocking circuitry.

- '0' - The multiple touch circuitry is disabled. The device will not block multiple touches.
- '1' (default) - The multiple touch circuitry is enabled. The device will accept the number of touches equal to programmed multiple touch threshold and block all others. It will remember which sensor is valid and block all others until that sensor has been released.

Bits 3 - 2 - B\_MULT\_T[1:0] - Determines the number of simultaneous touches on all buttons (excluding the Grouped buttons) before a Multiple Touch Event is flagged. If the number of multiple buttons touches is greater than the threshold value, a Multiple Touch Event is flagged. The bit decode is given by [Table 6.32](#).

Table 6.32 B\_MULT\_T Bit Decode

| B_MULT_T[1:0] |   | NUMBER OF SIMULTANEOUS TOUCHES |
|---------------|---|--------------------------------|
| 1             | 0 |                                |
| 0             | 0 | 1 (default)                    |
| 0             | 1 | 2                              |
| 1             | 0 | 3                              |
| 1             | 1 | 4                              |

Bits 1 - 0 - G\_MULT\_T[1:0] - Determines the number of simultaneous touches on all Grouped buttons before a Multiple Touch Event is flagged. If the number of multiple buttons touches is greater than the threshold value, a Multiple Touch Event is flagged. The bit decode is given by [Table 6.33](#).

Table 6.33 G\_MULT\_T Bit Decode

| G_MULT_T[1:0] |   | NUMBER OF SIMULTANEOUS TOUCHES |
|---------------|---|--------------------------------|
| 1             | 0 |                                |
| 0             | 0 | 2                              |
| 0             | 1 | 3                              |

Table 6.33 G\_MULT\_T Bit Decode (continued)

| G_MULT_T[1:0] |   | NUMBER OF SIMULTANEOUS TOUCHES |
|---------------|---|--------------------------------|
| 1             | 0 |                                |
| 1             | 0 | 4 (default)                    |
| 1             | 1 | 1                              |

## 6.24 Lid Closure Configuration Register

Table 6.34 Lid Closure Configuration Register

| ADDR | R/W | REGISTER           | B7        | B6 | B5 | B4 | B3 | B2 | B1        | B0       | DEFAULT |
|------|-----|--------------------|-----------|----|----|----|----|----|-----------|----------|---------|
| 2Bh  | R/W | Lid Closure Config | LID_CLOSE | -  | -  | -  | -  | -  | COMP_PTRN | LID_ALRT | 00h     |

The Lid Closure Configuration Register controls the settings for the lid closure detection circuitry.

Bit 7 - LID\_CLOSE - Enables the lid closure circuitry.

- '0' (default) - The lid closure circuitry is disabled.
- '1' The lid closure circuitry is enabled. The device will use the Lid Closure Status registers in combination with the Lid Closure Pattern register settings to determine when a Lid Closure Event is flagged. In addition, the Noise Status bits are associated with lid closure.

Bit 1 - COMP\_PTRN - Determines how the Lid Closure Status registers are compared against the Lid Closure Pattern registers. See [Section 6.26](#) for details on how the Lid Closure Pattern registers are used.

- '0' (default) - The Lid Closure Status registers are not compared directly against the Lid Closure Pattern registers. Instead, the number of bits in the Lid Closure Status registers is compared to the number of bits in the Lid Closure Pattern registers to determine whether a Lid Closure Event is flagged.
- '1' - The Lid Closure Status registers are compared directly against the Lid Closure Pattern registers. If the bits set in the Lid Closure Pattern are also set in the Lid Status registers, a Lid Closure Event is flagged.

Bit 0 - LID\_ALRT - Enables an interrupt if a Lid Closure Event occurs.

- '0' (default) - If a Lid Closure Event occurs, the ALERT pin is not asserted.
- '1' - If a Lid Closure Event occurs, the ALERT pin will be asserted.

## 6.25 Lid Closure Queue Control Register

Table 6.35 Lid Closure Queue Control Register

| ADDR | R/W | REGISTER                  | B7 | B6 | B5 | B4 | B3 | B2             | B1 | B0 | DEFAULT |
|------|-----|---------------------------|----|----|----|----|----|----------------|----|----|---------|
| 2Ch  | R/W | Lid Closure Queue Control | -  | -  | -  | -  | -  | QUEUE_L_B[2:0] |    |    | 02h     |

The Lid Closure Queue Control Register determines the number of consecutive samples for which a single sensor output is above the Lid Closure Threshold before it is flagged.

A value of 0000b is decoded as 1.

## Datasheet

Bits 2 - 0 - QUEUE\_L[2:0] - The number of consecutive samples from an individual sensor necessary to set the Lid Closure status bit associated with the sensor. The queue applies individually to all sensors (including both buttons and grouped sensors) and applies to setting and clearing the respective status bit. The queue can range from 1 sample to 8 consecutive samples with a default of 2 consecutive samples.

## 6.26 Lid Closure Pattern Registers

Table 6.36 Lid Closure Pattern Registers

| ADDR | R/W | REGISTER              | B7 | B6     | B5     | B4     | B3     | B2     | B1    | B0    | DEFAULT |
|------|-----|-----------------------|----|--------|--------|--------|--------|--------|-------|-------|---------|
| 2Dh  | R/W | Lid Closure Pattern 1 | -  | S7_LM  | S6_LM  | S5_LM  | S4_LM  | S3_LM  | S2_LM | S1_LM | 7Fh     |
| 2Eh  | R/W | Lid Closure Pattern 2 |    | S14_LM | S13_LM | S12_LM | S11_LM | S10_LM | S9_LM | S8_LM | 7Fh     |

The Lid Closure Pattern Registers act as a pattern to identify an expected sensor profile that is consistent with lid closure. They are only used when lid closure is enabled (see [Section 6.24, "Lid Closure Configuration Register"](#)). There are two methods for how the Lid Closure Status Registers are used with the Lid Closure Pattern registers: as specific sensors that must exceed the lid closure threshold or as the number of sensors that must exceed the lid closure threshold. Which method is used is based on bit 1 in the Lid Closure Configuration Register. The methods are described below. A Lid Closure Event is flagged in the Group Status register (see [Section 6.10, "Group Status Register"](#)).

1. Specific Sensors: If the bits set in the Lid Closure Pattern are also set in the Lid Status registers, a Lid Closure Event is flagged.
2. Number of Sensors: The number of bits in the Lid Closure Status registers is compared to the number of bits in the Lid Closure Pattern registers to determine whether a Lid Closure Event is flagged. If any one of the conditions below is met, the Lid Closure Event is flagged.
  - If the number of bits in Lid Closure Status 1 register equals or exceeds the number of bits in the Lid Closure Pattern 1 register, a Lid Closure Event is flagged. In other words, if the number of simultaneous sensors 1-7 exceeding the lid closure threshold meets or exceeds the number of bits in the Lid Closure Pattern 1 register, a Lid Closure Event is flagged.
  - If the number of bits in Lid Closure Status 2 register equals or exceeds the number of bits in the Lid Closure Pattern 2 register, a Lid Closure Event is flagged. In other words, if the number of simultaneous grouped sensors 8-14 exceeding the lid closure threshold meets or exceeds the number of bits in the Lid Closure Pattern 2 register, a Lid Closure Event is flagged.
  - If the total number of bits in both the Lid Closure Status 1 and 2 registers equals or exceeds the total number of bits in both the Lid Closure Pattern 1 and 2 registers, a Lid Closure Event is flagged. In other words, if the total number of sensors above the lid closure threshold is greater than or equal to the number of sensors required for both Lid Closure Patterns, a Lid Closure Event is flagged.
  - A value of 00h in both registers will effectively disable the Lid Closure circuitry and clear the LID status bit.

## 6.27 Recalibration Configuration Register

Table 6.37 Recalibration Configuration Register

| ADDR | R/W | REGISTER                    | B7        | B6       | B5 | B4                 | B3 | B2           | B1 | B0 | DEFAULT |
|------|-----|-----------------------------|-----------|----------|----|--------------------|----|--------------|----|----|---------|
| 2Fh  | R/W | Recalibration Configuration | BUT_LD_TH | GP_LD_TH | -  | NEG_DELTA_CNT[1:0] |    | CAL_CFG[2:0] |    |    | 93h     |

The Recalibration Configuration Register controls the automatic re-calibration routine settings as well as advanced controls to program the Sensor Threshold register settings and interrupt behavior.

Bit 7 - BUT\_LD\_TH - Enables setting all button Sensor Threshold registers by writing to the Sensor 1 Threshold register.

- '0' - Each Sensor X Threshold register is updated individually.
- '1' (default) - Writing the Sensor 1 Threshold register will automatically overwrite the Sensor Threshold registers for all buttons (Sensor Threshold 1 through Sensor Threshold 7). The individual Sensor X Threshold registers (Sensor 2 Threshold through Sensor 7 Threshold) can be individually updated at any time.

Bit 6 - GP\_LD\_TH - Enables setting the Group Threshold register by writing to the Sensor 1 Threshold register.

- '0' (default) - The Group Threshold register is updated independently of the Sensor 1 Threshold register.
- '1' - Writing the Sensor 1 Threshold register automatically overwrites the Group Threshold register settings.

Bits 4 - 3 - NEG\_DELTA\_CNT[1:0] - Determines the number of negative delta counts necessary to trigger a digital re-calibration as shown in [Table 6.38](#).

Table 6.38 NEG\_DELTA\_CNT Bit Decode

| NEG_DELTA_CNT[1:0] |   | NUMBER OF CONSECUTIVE NEGATIVE DELTA COUNT VALUES |
|--------------------|---|---|
| 1                  | 0 |   |
| 0                  | 0 | 8   |
| 0                  | 1 | 16  |
| 1                  | 0 | 32 (default)                                      |
| 1                  | 1 | None (disabled)                                   |

Bits 2 - 0 - CAL\_CFG[2:0] - Determines the update time and number of samples of the automatic re-calibration routine. The settings apply to all sensors universally (though individual sensors and the group can be configured to support re-calibration - see [Section 6.19](#)).

Table 6.39 CAL\_CFG Bit Decode

| CAL_CFG[2:0] |   |   | RECALIBRATION<br>SAMPLES (SEE<br>Note 6.1) | UPDATE TIME (SEE<br>Note 6.2) |
|--------------|---|---|--|-------------------------------|
| 2            | 1 | 0 |  |                               |
| 0            | 0 | 0 | 16   | 16                            |
| 0            | 0 | 1 | 32   | 32                            |
| 0            | 1 | 0 | 64   | 64                            |
| 0            | 1 | 1 | 256  | 256 (default)                 |
| 1            | 0 | 0 | 256  | 1024                          |
| 1            | 0 | 1 | 256  | 2048                          |
| 1            | 1 | 0 | 256  | 4096                          |
| 1            | 1 | 1 | 256  | 7936                          |

**Note 6.1** Recalibration Samples refers to the number of samples that are measured and averaged before the Base Count is updated.

**Note 6.2** Update Time refers to the amount of time (in polling cycle periods) that elapses before the Base Count is updated.

## 6.28 Sensor Threshold Registers

Table 6.40 Sensor Threshold Registers

| ADDR | R/W | REGISTER           | B7 | B6 | B5 | B4 | B3 | B2 | B1 | B0 | DEFAULT |
|------|-----|--------------------|----|----|----|----|----|----|----|----|---------|
| 30h  | R/W | Sensor 1 Threshold | -  | 64 | 32 | 16 | 8  | 4  | 2  | 1  | 40h     |
| 31h  | R/W | Sensor 2 Threshold | -  | 64 | 32 | 16 | 8  | 4  | 2  | 1  | 40h     |
| 32h  | R/W | Sensor 3 Threshold | -  | 64 | 32 | 16 | 8  | 4  | 2  | 1  | 40h     |
| 33h  | R/W | Sensor 4 Threshold | -  | 64 | 32 | 16 | 8  | 4  | 2  | 1  | 40h     |
| 34h  | R/W | Sensor 5 Threshold | -  | 64 | 32 | 16 | 8  | 4  | 2  | 1  | 40h     |
| 35h  | R/W | Sensor 6 Threshold | -  | 64 | 32 | 16 | 8  | 4  | 2  | 1  | 40h     |
| 36h  | R/W | Sensor 7 Threshold | -  | 64 | 32 | 16 | 8  | 4  | 2  | 1  | 40h     |
| 37h  | R/W | Group Threshold    | -  | 64 | 32 | 16 | 8  | 4  | 2  | 1  | 40h     |

The Sensor Threshold Registers store the delta threshold that is used to determine if a touch has been detected. When a touch occurs, the input signal of the corresponding sensor changes due to the



capacitance associated with a touch. If the sensor input change exceeds the threshold settings, a touch is detected.

When the BUT\_LD\_TH bit is set (see [Section 6.27](#) - bit 7), writing data to the Sensor 1 Threshold register will update all of the button threshold registers (31h - 36h inclusive).

When the GP\_LD\_TH bit is set (see [Section 6.27](#) - bit 6), writing data to the Sensor 1 Threshold register (30h) will update the Group Threshold register (37h) and the CS14 Threshold register (40h).

Individual button registers may be updated independently of the Sensor 1 Threshold settings. Similarly, the Up and Down Threshold registers may be updated independently of the Group Threshold register.

## 6.29 Button Noise Threshold Registers

**Table 6.41 Button Noise Threshold Registers**

| ADDR | R/W | REGISTER                 | B7                 | B6 | B5                 | B4 | B3                 | B2 | B1                 | B0 | DEFAULT |
|------|-----|--------------------------|--------------------|----|--------------------|----|--------------------|----|--------------------|----|---------|
| 38h  | R/W | Button Noise Threshold 1 | CS4_BN_TH<br>[1:0] |    | CS3_BN_TH<br>[1:0] |    | CS2_BN_TH<br>[1:0] |    | CS1_BN_TH<br>[1:0] |    | AAh     |
| 39h  | R/W | Button Noise Threshold 2 | GR_BN_TH<br>[1:0]  |    | CS7_BN_TH<br>[1:0] |    | CS6_BN_TH<br>[1:0] |    | CS5_BN_TH<br>[1:0] |    | AAh     |

The Button Noise Threshold Registers control the value of a secondary internal threshold to detect noise and improve the automatic recalibration routine. If a Capacitive Touch Sensor output exceeds the Button Noise Threshold but does not exceed the sensor threshold, it is determined to be caused by a noise spike. That sample is not used by the automatic re-calibration routine.

The Button Noise Threshold is proportional to the programmed threshold as shown in [Table 6.42](#).

**Table 6.42 CSx\_BN\_TH Bit Decode**

| CSX_BN_TH[1:0] |   | THRESHOLD DIVIDE SETTING |
|----------------|---|--------------------------|
| 1              | 0 |                          |
| 0              | 0 | 6.25%                    |
| 0              | 1 | 12.5%                    |
| 1              | 0 | 25% (default)            |
| 1              | 1 | 50%                      |

### 6.29.1 Button Noise Threshold 1 Register

The Button Noise Threshold 1 Register controls the noise threshold for Capacitive Touch Sensors 1-4.

Bits 7-6 - CH4\_BN\_TH[1:0] - Controls the noise threshold for Capacitive Touch Sensor 4.

Bits 5-4 - CH3\_BN\_TH[1:0] - Controls the noise threshold for Capacitive Touch Sensor 3.

Bits 3-2 - CH2\_BN\_TH[1:0] - Controls the noise threshold for Capacitive Touch Sensor 2.

Bits 1-0 - CH1\_BN\_TH[1:0] - Controls the noise threshold for Capacitive Touch Sensor 1.

## Datasheet

## 6.29.2 Button Noise Threshold 2 Register

The Button Noise Threshold 2 Register controls the noise threshold for Capacitive Touch Sensors 5 - 7 and the Grouped sensors.

Bits 7-6 - GR\_BN\_TH[1:0] - Controls the noise threshold for all grouped Capacitive Touch Sensors.

Bits 5-4 - CH7\_BN\_TH[1:0] - Controls the noise threshold for Capacitive Touch Sensor 7.

Bits 3-2 - CH6\_BN\_TH[1:0] - Controls the noise threshold for Capacitive Touch Sensor 6.

Bits 1-0 - CH5\_BN\_TH[1:0] - Controls the noise threshold for Capacitive Touch Sensor 5.

## 6.30 Lid Closure Threshold Registers

Table 6.43 Lid Closure Threshold Registers

| ADDR | R/W | REGISTER                | B7               | B6 | B5               | B4 | B3               | B2 | B1               | B0 | DEFAULT |
|------|-----|-------------------------|------------------|----|------------------|----|------------------|----|------------------|----|---------|
| 3Ah  | R/W | Lid Closure Threshold 1 | CS4_LD_TH [1:0]  |    | CS3_LD_TH [1:0]  |    | CS2_LD_TH [1:0]  |    | CS1_LD_TH [1:0]  |    | AAh     |
| 3Bh  | R/W | Lid Closure Threshold 2 | CS8_LD_TH [1:0]  |    | CS7_LD_TH [1:0]  |    | CS6_LD_TH [1:0]  |    | CS5_LD_TH [1:0]  |    | AAh     |
| 3Ch  | R/W | Lid Closure Threshold 3 | CS12_LD_TH [1:0] |    | CS11_LD_TH [1:0] |    | CS10_LD_TH [1:0] |    | CS9_LD_TH [1:0]  |    | AAh     |
| 3Dh  | R/W | Lid Closure Threshold 4 | -                | -  | -                | -  | CS14_LD_TH [1:0] |    | CS13_LD_TH [1:0] |    | 0Ah     |

The Lid Closure Threshold Registers control the value of a secondary internal threshold to detect noise potentially generated by lid closure. If a Capacitive Touch Sensor output exceeds the Lid Closure Threshold, the appropriate status bit is set in the Lid Closure Status register (see [Section 6.8](#)).

The Lid Closure Threshold is proportional to the programmed Sensor Threshold as shown in [Table 6.44](#).

Table 6.44 CSx\_LD\_TH Bit Decode

| CSX_LD_TH[1:0] |   | THRESHOLD DIVIDE SETTING |
|----------------|---|--------------------------|
| 1              | 0 |                          |
| 0              | 0 | 6.25%                    |
| 0              | 1 | 12.5%                    |
| 1              | 0 | 25% (default)            |
| 1              | 1 | 50%                      |

### 6.30.1 Lid Closure Threshold 1 Register

The Lid Closure Threshold 1 Register controls the lid closure threshold for Capacitive Touch Sensors 1-4.

Bits 7-6 - CS4\_LD\_TH[1:0] - Controls the lid closure threshold for Capacitive Touch Sensor 4.

Bits 5-4 - CS3\_LD\_TH[1:0] - Controls the lid closure threshold for Capacitive Touch Sensor 3.

Bits 3-2 - CS2\_LD\_TH[1:0] - Controls the noise threshold for Capacitive Touch Sensor 2.

Bits 1-0 - CS1\_LD\_TH[1:0] - Controls the noise threshold for Capacitive Touch Sensor 1.

### 6.30.2 Lid Closure Threshold 2 Register

The Lid Closure Threshold 2 Register controls the lid closure threshold for Capacitive Touch Sensors 5 - 8.

Bits 7-6 - CS8\_LD\_TH[1:0] - Controls the lid closure threshold for Capacitive Touch Sensor 8 (one of the grouped sensors).

Bits 5-4 - CS7\_LD\_TH[1:0] - Controls the lid closure threshold for Capacitive Touch Sensor 7.

Bits 3-2 - CS6\_LD\_TH[1:0] - Controls the lid closure threshold for Capacitive Touch Sensor 6.

Bits 1-0 - CS5\_LD\_TH[1:0] - Controls the lid closure threshold for Capacitive Touch Sensor 5.

### 6.30.3 Lid Closure Threshold 3 Register

The Lid Closure Threshold 3 Register controls the lid closure threshold for Capacitive Touch Sensors 9 - 12.

Bits 7-6 - CS12\_LD\_TH[1:0] - Controls the lid closure threshold for Capacitive Touch Sensor 12 (one of the grouped sensors).

Bits 5-4 - CS11\_LD\_TH[1:0] - Controls the lid closure threshold for Capacitive Touch Sensor 11 (one of the grouped sensors).

Bits 3-2 - CS10\_LD\_TH[1:0] - Controls the lid closure threshold for Capacitive Touch Sensor 10 (one of the grouped sensors).

Bits 1-0 - CS9\_LD\_TH[1:0] - Controls the lid closure threshold for Capacitive Touch Sensor 9 (one of the grouped sensors).

### 6.30.4 Lid Closure Threshold 4 Register

The Lid Closure Threshold 4 Register controls the lid closure threshold for Capacitive Touch Sensors 13 - 14.

Bits 3-2 - CS14\_LD\_TH[1:0] - Controls the lid closure threshold for Capacitive Touch Sensor 14 (one of the grouped sensors).

Bits 1-0 - CS13\_LD\_TH[1:0] - Controls the lid closure threshold for Capacitive Touch Sensor 13 (one of the grouped sensors).

## 6.31 Slider Velocity Configuration Register

Table 6.45 Slider Velocity Configuration Register

| ADDR | R/W | REGISTER                      | B7         | B6           | B5 | B4 | B3               | B2 | B1              | B0 | DEFAULT |
|------|-----|-------------------------------|------------|--------------|----|----|------------------|----|-----------------|----|---------|
| 3Eh  | R/W | Slider Velocity Configuration | ACC_INT_EN | MAX_INT[2:0] |    |    | SLIDE_TIME [1:0] |    | RPT_SCALE [1:0] |    | C5h     |

The Slider Velocity Configuration Register controls the speed sensitive behaviors of the slider, allowing the number of interrupts to be increased as the slide speed increases.

## Datasheet

Bit 7 - ACC\_INT\_EN - Enables the device to generate extra interrupts after an accelerated slide has been detected.

- '0' - The device will not generate extra interrupts during or after the slide has been detected.
- '1' (default) - The device will generate extra interrupts after an accelerated slide is detected. The number of extra interrupts generated will be proportional to the speed of the accelerated slide but will not exceed the maximum number of extra interrupts as determined by the MAX\_INT bits.

Bits 6-4 - MAX\_INT[2:0] - (default 100b) Determine the maximum number of extra interrupts that will be generated after a single slide (regardless of length). The variable "T" is the actual slide time and the parameter SLIDE\_TIME is set by bits [3:2] of this register.

Table 6.46 MAX\_INT Bit Decode

| MAX_INT[2:0] |   |   | MAX #<br>INTERRUPTS | # INTERRUPTS<br>FOR T < 1/2<br>SLIDE_TIME | # INTERRUPTS<br>FOR 1/2 < T <<br>3/4 SLIDE_TIME | # INTERRUPTS<br>FOR 3/4 < T <<br>FULL<br>SLIDE_TIME |
|--------------|---|---|---------------------|---|---|---|
| 2            | 1 | 0 |                     |   |   |   |
| 0            | 0 | 0 | 0                   | 0   | 0   | 0   |
| 0            | 0 | 1 | 1                   | 1   | 0   | 0   |
| 0            | 1 | 0 | 2                   | 2   | 1   | 0   |
| 0            | 1 | 1 | 3                   | 3   | 1   | 0   |
| 1            | 0 | 0 | 4                   | 4   | 2   | 1   |
| 1            | 0 | 1 | 5                   | 5   | 2   | 1   |
| 1            | 1 | 0 | 6                   | 6   | 3   | 1   |
| 1            | 1 | 1 | 7                   | 7   | 3   | 1   |

Bits 3-2 - SLIDE\_TIME[1:0] - (default 01b) - Determines how fast a slide must be to generate extra interrupts. This is the maximum slide time that will result in extra interrupts being generated. If the slide time is greater than SLIDE\_TIME, no extra interrupts will be generated.

Table 6.47 SLIDE\_TIME Bit Decode

| SLIDE_TIME[1:0] |   | APPROXIMATE SLIDE TIME (MSEC) |
|-----------------|---|-------------------------------|
| 1               | 0 |                               |
| 0               | 0 | 350                           |
| 0               | 1 | 560 (default)                 |
| 1               | 0 | 770                           |
| 1               | 1 | 980                           |

Bits 1 - 0 - RPT\_SCALE[1:0] - (default 01b) - Determines how much to increase the Repeat Rate based on slide speed. The slide speed is determined by counting how many sensors are touched in approximately 100msec. The Repeat Rate is then increased various amounts based on the RPT\_SCALE parameter.

When read in [Table 6.48](#), the repeat rate given is the number of measurement cycles between interrupts generated.

Table 6.48 RPT\_SCALE Bit Decode

| NUMBER OF SENSORS IN<br>100MSEC | REPEAT RATE (MSEC)<br>RPT_SCALE[1:0] |    |     |     |
|---------------------------------|--------------------------------------|----|-----|-----|
|                                 | 00                                   | 01 | 10  | 11  |
| >=5                             | 35                                   | 35 | 35  | 35  |
| 4                               | 35                                   | 35 | 35  | 70  |
| 3                               | 35                                   | 35 | 70  | 105 |
| 2                               | 35                                   | 70 | 105 | 140 |
| 1                               | RPT_RATE_SL                          |    |     |     |

**Note 6.3** If the repeat rate for the slider is set at 105msec or lower, the 11b case will use the fixed values of 140, 105 and 70msec, respectively.

## 6.32 Digital Recalibration Control Register

Table 6.49 Digital Recalibration Control Register

| ADDR | R/W | REGISTER                            | B7           | B6            | B5            | B4            | B3            | B2            | B1            | B0            | DEFAULT |
|------|-----|-------------------------------------|--------------|---------------|---------------|---------------|---------------|---------------|---------------|---------------|---------|
| 3Fh  | R/W | Digital<br>Recalibration<br>Control | GP_<br>D_CAL | CS7_<br>D_CAL | CS6_<br>D_CAL | CS5_<br>D_CAL | CS4_<br>D_CAL | CS3_<br>D_CAL | CS2_<br>D_CAL | CS1_<br>D_CAL | 00h     |

The Digital Recalibration Control Register forces channels to perform a digital calibration as if there were no base count. When a bit is set, the corresponding Capacitive Touch Sensor will be re-calibrated and the bit will be automatically cleared once the re-calibration routine has finished. This calibration routine will update the base count for touch detection.

Bit 7 - GP\_D\_CAL - Forces the grouped sensors to perform a digital recalibration as if there were no base count.

Bit 6 - CS7\_D\_CAL - Forces CS7 to perform a digital recalibration as if there were no base count.

Bit 5 - CS6\_D\_CAL - Forces CS6 to perform a digital recalibration as if there were no base count.

Bit 4 - CS5\_D\_CAL - Forces CS5 to perform a digital recalibration as if there were no base count.

Bit 3 - CS4\_D\_CAL - Forces CS4 to perform a digital recalibration as if there were no base count.

Bit 2 - CS3\_D\_CAL - Forces CS3 to perform a digital recalibration as if there were no base count.

Bit 1 - CS2\_D\_CAL - Forces CS2 to perform a digital recalibration as if there were no base count.

Bit 1 - CS1\_D\_CAL - Forces CS1 to perform a digital recalibration as if there were no base count.

## 6.33 Configuration 2 Register

Table 6.50 Configuration 2 Register

| ADDR | R/W | REGISTER        | B7            | B6 | B5 | B4          | B3            | B2           | B1          | B0        | DEFAULT |
|------|-----|-----------------|---------------|----|----|-------------|---------------|--------------|-------------|-----------|---------|
| 40h  | R/W | Configuration 2 | INV_LINK_TRAN | -  | -  | BLK_POL_MIR | SHOW_RF_NOISE | BLK_RF_NOISE | VOL_UP_DOWN | INT_REL_n | 00h     |

Bit 7 - INV\_LINK\_TRAN - Determines the behavior of the Linked LED Transition controls (see [Section 6.45, "Linked LED Transition Control Registers"](#)).

- '0' (default) - When set, the Linked LED Transition controls set the min duty cycle equal to the max duty cycle.
- '1' - When set, the Linked LED Transition controls will invert the touch signal. For example, a touch signal will be inverted to a non-touched signal.

Bit 4 - BLK\_POL\_MIR - Determines whether the LED Mirror Control register bits are linked to the LED Polarity bits.

- '0' (default) - When the LED Polarity controls are set, the corresponding LED Mirror control is automatically set. Likewise, when the LED Polarity controls are cleared, the corresponding LED Mirror control is cleared.
- '1' - When the LED Polarity controls are changed, the corresponding LED Mirror control is not automatically changed.

Bit 3 - SHOW\_RF\_NOISE - Determines whether the Noise Status bits will show RF Noise as the only input source.

- '0' (default) - The Noise Status registers will show both RF noise and low frequency noise if either is detected on a Capacitive Touch Sensor channel.
- '1' - The Noise Status registers will only show RF noise if it is detected on a Capacitive Touch Sensor channel. Generic noise will still be detected and touches will be blocked normally; however, the status bits will not be updated.

Bit 2 - BLK\_RF\_NOISE - Blocks the analog RF noise detector from preventing touches.

- '0' (default) - If RF noise is detected by the analog block, any pending touch is blocked on the corresponding channel. During the analog calibration routine, RF Noise will cause it to retry. Note that this does not require that Noise Status bits be set.
- '1' - A touch is not blocked even if RF noise is detected. Likewise, the analog calibration routine will not retry if RF noise is detected.

Bit 1 - VOL\_UP\_DOWN - Determines how the Grouped Sensors are to be used.

- '0' (default) - The grouped sensors are used as a slider. All seven of the sensors are sampled together and may be disabled as a whole using the GP\_EN (see [Section 6.15](#)) or GSLEEP (see [Section 6.22](#)) controls or individually (using the Grouped Sensor Channel Enable register - see [Section 6.34](#)). Alternately, each sensor may be disabled individually via the Group Sensor Channel Enable register. They will use the Group Threshold settings for all touch detections.
- '1' - The grouped sensors are used as separate sensors and are not grouped. They will behave as follows:
  1. Each sensor will flag individual interrupts when a touch is detected. They will set the corresponding status bit in the Button Status 2 register.
  2. The UP / DOWN, TAP, or PH status bits will not be set for CS9, CS10, CS11, CS12, or CS13. No slide will be detected.
  3. Each sensor will use the Group Threshold settings.

4. Each sensor can be individually enabled / disabled via the Grouped Sensor Enable register settings.
5. All sensors except CS8 and CS14 will use the button queue controls and repeat rates.
6. The CS8 and CS14 sensors will use the tap and press and hold logic as well as the group repeat rate settings.
7. All sensors will use the group max duration settings if this feature is enabled via the MAX\_DUR\_EN\_G bit.
8. For CS8 and CS14, interrupts will be generated in the same way as they would be for a TAP or Press and Hold event. This means that an interrupt will be generated on a touch. If the button is held, interrupts will be generated at the Group Repeat rate until the button is released. These buttons do not use the INT\_REL\_n control and will only generate an interrupt when a touch is detected.
9. The CS8 sensor will be the designated “DOWN” button. When a tap or Press and Hold event is detected, it will cause the DOWN status bit to be set. The TAP and PH status bits will be set normally.
10. The CS14 sensor will be the designated “UP” button. When a Tap or Press and Hold event is detected, it will cause the UP status bit to be set. The TAP and PH status bits will be set normally.

Bit 0 - INT\_REL\_n - Controls the interrupt behavior when a release is detected on a button.

- '0' (default) - An interrupt is generated when a press is detected and again when a release is detected and at the repeat rate (if enabled - see [Section 6.14](#) and [Section 6.33](#)).
- '1' - An interrupt is generated when a press is detected and at the repeat rate (if enabled - see [Section 6.14](#) and [Section 6.33](#)).

## 6.34 Grouped Sensor Channel Enable Register

Table 6.51 Grouped Sensor Channel Enable Register

| ADDR | R/W | REGISTER                      | B7 | B6      | B5      | B4      | B3      | B2      | B1     | B0     | DEFAULT |
|------|-----|-------------------------------|----|---------|---------|---------|---------|---------|--------|--------|---------|
| 41h  | R/W | Grouped Sensor Channel Enable | -  | CS14_EN | CS13_EN | CS12_EN | CS11_EN | CS10_EN | CS9_EN | CS8_EN | 7Fh     |

The Grouped Sensor Channel Enable Register enables sensors within Grouped Sensors to be sampled during the polling cycle. This register may be updated at any time. If the grouped sensors are treated as a group (see [Section 6.33](#)), then disabling one or more sensors will cause the slider to behave erratically or not at all.

Bit 6 - CS14\_EN - Enables the CS14 sensor to be sampled in the polling cycle.

Bit 5 - CS13\_EN - Enables the CS13 sensor to be sampled in the polling cycle.

Bit 4 - CS12\_EN - Enables the CS12 sensor to be sampled in the polling cycle.

Bit 3 - CS11\_EN - Enables the CS11 sensor to be sampled in the polling cycle.

Bit 2 - CS10\_EN - Enables the CS10 sensor to be sampled in the polling cycle.

Bit 1 - CS9\_EN - Enables the CS9 sensor to be sampled in the polling cycle.

Bit 0 - CS8\_EN - Enables the CS8 sensor to be sampled in the polling cycle.

## 6.35 Proximity Control Register

Table 6.52 Proximity Control Register

| ADDR | R/W | REGISTER          | B7       | B6       | B5 | B4             | B3 | B2                | B1 | B0 | DEFAULT |
|------|-----|-------------------|----------|----------|----|----------------|----|-------------------|----|----|---------|
| 42h  | R/W | Proximity Control | CS1_PROX | PROX_SUM | -  | PROX_AVG [1:0] |    | PROX_D_SENSE[2:0] |    |    | 02h     |

The Proximity Control Register controls sensitivity settings for CS1.

Bit 7 - CS1\_PROX - Determines the functionality of the CS1 channel.

- '0' (default) - The CS1 channel is not measuring proximity. It will use the standard button queue and data sensitivity controls. The Averaging will be set to a value of '1'. Writing to the PROX\_AVG[2:0] bits will change the averaging applied to CS1 (and only CS1).
- '1' - The CS1 channel is measuring proximity. It will not use the queue. In addition, the CS1 channel will not use the DELTA\_SHIFT[2:0] sensitivity settings and will instead use the PROX\_D\_SHIFT[2:0] settings. In proximity mode, the signal is boosted by 8X to detect very small capacitance changes.

Bit 6 - PROX\_SUM - Determines whether the CS1 channel averaging will perform an average or calculate the sum of the measured channel when comparing the delta count against the threshold.

- '0' (default) - When configured to detect proximity, the CS1 channel delta counts will be the average.
- '1' - When configured to detect proximity, the CS1 channel will sum the results of the averages rather than report the true average. This value will be compared against the threshold normally. Note that this mode is intended for very small signal detection. Because the delta count is the summation of several consecutive measurements, it may become very large. Adjustments to the sensitivity and threshold values will be required to maintain proper operation.

Bits 5 - 3 - PROX\_AVG[1:0] - Determines the averaging value used when CS1 is set to detect proximity. When averaging is enabled (i.e. not set at a value of '1'), the CS1 sensor will be sampled the average number of times consecutively during the same polling cycle. The delta counts are summed and then divided by the number of averages to get an average delta which is compared against the threshold normally.

This will increase the time of the polling cycle linearly with the number of averages taken. As the polling cycle time is used to set the update rate, repeat rate, and recalibration times, these will likewise increase. See [Table 6.53](#).

Table 6.53 PROX\_AVG Bit Decode

| PROX_AVG[1:0] |   | NUMBER OF DIGITAL AVERAGES | POLLING CYCLE TIME INCREASE (SEE <a href="#">Note 6.4</a> ) |
|---------------|---|----------------------------|---|
| 1             | 0 |                            |   |
| 0             | 0 | 16 (default)               | +38.4ms   |
| 0             | 1 | 32                         | +79.36ms  |
| 1             | 0 | 64                         | +161.28ms   |
| 1             | 1 | 128                        | +325.12ms   |

**Note 6.4** The Polling time increase is based on the default sampling time as determined by the Sampling Configuration register (see [Section 6.37](#)).



Bits 2 - 0 - PROX\_D\_SENSE[2:0] - Controls the sensitivity of proximity detection on CS1. The sensitivity settings act to scale the relative delta count value higher or lower based on the system parameters. A setting of 0000b is the most sensitive while a setting of 1111b is the least sensitive. At the more sensitive settings, touches are detected for a smaller delta C corresponding to a “lighter” touch. These settings are more sensitive to noise, however, and a noisy environment may flag more false touches than less sensitive levels. See [Table 6.17](#).

## 6.36 Sampling Channel Select Register

Table 6.54 Sampling Channel Select Register

| ADDR | R/W | REGISTER                | B7   | B6    | B5    | B4    | B3    | B2    | B1    | B0    | DEFAULT |
|------|-----|-------------------------|------|-------|-------|-------|-------|-------|-------|-------|---------|
| 4Eh  | R/W | Sampling Channel Select | GR_S | CS7_S | CS6_S | CS5_S | CS4_S | CS3_S | CS2_S | CS1_S | 00h     |

The Sampling Channel Select Register determines which (if any) Capacitive Sensor input is controlled by the Sampling Configuration register.

Bit 7 - GR\_S - Determines if all grouped sensors are controlled by the Sampling Configuration register settings.

- '0' (default) - The grouped sensors are not controlled by the Sampling Configuration register settings. All Grouped sensors will be sampled in a 2.5ms window of the entire polling cycle (which requires 35ms).
- '1' - The grouped sensors are controlled by the Sampling Configuration register settings. Each sensor sampling window will be determined based on these bit settings and the overall polling cycle time will increase.

Bit 6 - CS7\_S - Determines if Capacitive Touch Sensor 7 is controlled by the Sampling Configuration register settings.

Bit 5 - CS6\_S - Determines if Capacitive Touch Sensor 6 is controlled by the Sampling Configuration register settings.

Bit 4 - CS5\_S - Determines if Capacitive Touch Sensor 5 is controlled by the Sampling Configuration register settings.

Bit 3 - CS4\_S - Determines if Capacitive Touch Sensor 4 is controlled by the Sampling Configuration register settings.

Bit 2 - CS3\_S - Determines if Capacitive Touch Sensor 3 is controlled by the Sampling Configuration register settings.

Bit 1 - CS2\_S - Determines if Capacitive Touch Sensor 2 is controlled by the Sampling Configuration register settings.

Bit 0 - CS1\_S - Determines if Capacitive Touch Sensor 1 is controlled by the Sampling Configuration register settings.

## 6.37 Sampling Configuration Register

Table 6.55 Sampling Configuration Register

| ADDR | R/W | REGISTER               | B7 | B6 | B5 | B4 | B3 | B2                 | B1 | B0  | DEFAULT |
|------|-----|------------------------|----|----|----|----|----|--------------------|----|-----|---------|
| 4Fh  | R/W | Sampling Configuration | -  | -  | -  | -  | -  | OVERSAMP_RATE[2:0] |    | 00h |         |

**Datasheet**

The Sampling Configuration Register controls the length of the sampling window of selected Capacitive Touch Sensor channels as indicated in the Sampling Channel Select register.

Increasing the sampling window time will have two effects. The first effect will be to increase the effective sensitivity of that particular channel so that a touch may be detected with a smaller  $\Delta C$ . However, at the larger sampling times, the resolution of the measurement is reduced.

The second effect will be increase the overall round robin rate (and all timing associated with the round robin rate such as re-calibration times, repeat rate times, and maximum duration times).

All Capacitive Touch Sensors default to a sampling time of 2.5ms. Increasing the sampling time of any single channel will increase the overall polling cycle by the same amount.

Bits 2 - 0 - OVERSAMP\_RATE[2:0] - Determine the time to take a single sample. This setting applies to all selected sensors.

**Table 6.56 OVERSAMP\_RATE Bit Decode**

| OVERSAMP_RATE[2:0] |   |   | SENSOR SAMPLING TIME |
|--------------------|---|---|----------------------|
| 2                  | 1 | 0 |                      |
| 1                  | 0 | 0 | 40.96ms              |
| 1                  | 0 | 1 | 20.48ms              |
| 1                  | 1 | 0 | 10.24ms              |
| 1                  | 1 | 1 | 5.12ms               |
| 0                  | 0 | 0 | 2.56ms (default)     |
| 0                  | 0 | 1 | 1.28ms               |
| 0                  | 1 | 0 | 0.64ms               |
| 0                  | 1 | 1 | 0.32ms               |

**6.38 Sensor Base Count Registers****Table 6.57 Sensor Base Count Registers**

| ADDR | R/W | REGISTER            | B7  | B6 | B5 | B4 | B3 | B2 | B1 | B0 | DEFAULT |
|------|-----|---------------------|-----|----|----|----|----|----|----|----|---------|
| 50h  | R   | Sensor 1 Base Count | 128 | 64 | 32 | 16 | 8  | 4  | 2  | 1  | 00h     |
| 51h  | R   | Sensor 2 Base Count | 128 | 64 | 32 | 16 | 8  | 4  | 2  | 1  | 00h     |
| 52h  | R   | Sensor 3 Base Count | 128 | 64 | 32 | 16 | 8  | 4  | 2  | 1  | 00h     |
| 53h  | R   | Sensor 4 Base Count | 128 | 64 | 32 | 16 | 8  | 4  | 2  | 1  | 00h     |
| 54h  | R   | Sensor 5 Base Count | 128 | 64 | 32 | 16 | 8  | 4  | 2  | 1  | 00h     |
| 55h  | R   | Sensor 6 Base Count | 128 | 64 | 32 | 16 | 8  | 4  | 2  | 1  | 00h     |

Table 6.57 Sensor Base Count Registers (continued)

| ADDR | R/W | REGISTER             | B7  | B6 | B5 | B4 | B3 | B2 | B1 | B0 | DEFAULT |
|------|-----|----------------------|-----|----|----|----|----|----|----|----|---------|
| 56h  | R   | Sensor 7 Base Count  | 128 | 64 | 32 | 16 | 8  | 4  | 2  | 1  | 00h     |
| 57h  | R   | Sensor 8 Base Count  | 128 | 64 | 32 | 16 | 8  | 4  | 2  | 1  | 00h     |
| 58h  | R   | Sensor 9 Base Count  | 128 | 64 | 32 | 16 | 8  | 4  | 2  | 1  | 00h     |
| 59h  | R   | Sensor 10 Base Count | 128 | 64 | 32 | 16 | 8  | 4  | 2  | 1  | 00h     |
| 5Ah  | R   | Sensor 11 Base Count | 128 | 64 | 32 | 16 | 8  | 4  | 2  | 1  | 00h     |
| 5Bh  | R   | Sensor 12 Base Count | 128 | 64 | 32 | 16 | 8  | 4  | 2  | 1  | 00h     |
| 5Ch  | R   | Sensor 13 Base Count | 128 | 64 | 32 | 16 | 8  | 4  | 2  | 1  | 00h     |
| 5Dh  | R   | Sensor 14 Base Count | 128 | 64 | 32 | 16 | 8  | 4  | 2  | 1  | 00h     |

The Sensor Base Count Registers store the calibrated “Not Touched” input value from the Capacitive Touch Sensor inputs. These registers are periodically updated by the re-calibration routine.

The routine uses an internal adder to add the current count value for each reading to the sum of the previous readings until sample size has been reached. At this point, the upper 16 bits are taken and used as the Sensor Base Count. The internal adder is then reset and the re-calibration routine continues.

The data presented is determined by the BASE\_SHIFT bits (see [Section 6.13](#)).

## 6.39 LED Status Registers

Table 6.58 LED Status Registers

| ADDR | R/W | REGISTER     | B7      | B6      | B5      | B4      | B3      | B2       | B1       | B0      | DEFAULT |
|------|-----|--------------|---------|---------|---------|---------|---------|----------|----------|---------|---------|
| 60h  | R   | LED Status 1 | LED8_DN | LED7_DN | LED6_DN | LED5_DN | LED4_DN | LED3_DN  | LED2_DN  | LED1_DN | 00h     |
| 61h  | R   | LED Status 2 | -       | -       | -       | -       | -       | LED11_DN | LED10_DN | LED9_DN | 00h     |

The LED Status Registers indicate which LED output has completed its actuated activity. The bits are cleared when the INT bit has been cleared. Likewise, these bits are cleared when the DSLEEP bit is set.

### 6.39.1 LED Status 1

Bit 7 - LED8\_DN - Indicates that LED8 has finished its ramping behavior as determined by the LED8\_CTL bits.

Bit 6 - LED7\_DN - Indicates that LED7 has finished its ramping behavior as determined by the LED7\_CTL bits.

**Datasheet**

Bit 5 - LED6\_DN - Indicates that LED6 has finished its ramping behavior as determined by the LED6\_CTL bits.

Bit 4 - LED5\_DN - Indicates that LED5 has finished its ramping behavior as determined by the LED5\_CTL bits.

Bit 3 - LED4\_DN - Indicates that LED4 has finished its ramping behavior as determined by the LED4\_CTL bits.

Bit 2 - LED3\_DN - Indicates that LED3 has finished its ramping behavior as determined by the LED3\_CTL bits.

Bit 1 - LED2\_DN - Indicates that LED2 has finished its ramping behavior as determined by the LED2\_CTL bits.

Bit 0 - LED1\_DN - Indicates that LED1 has finished its ramping behavior as determined by the LED1\_CTL bits.

**6.39.2 LED Status 2**

Bit 2 - LED11\_DN - Indicates that LED11 has finished its ramping behavior as determined by the LED3\_CTL bits.

Bit 1 - LED10\_DN - Indicates that LED10 has finished its ramping behavior as determined by the LED2\_CTL bits.

Bit 0 - LED9\_DN - Indicates that LED9 has finished its ramping behavior as determined by the LED1\_CTL bits.

**6.40 LED / GPIO Direction Register****Table 6.59 LED / GPIO Direction Register**

| ADDR | R/W | REGISTER             | B7       | B6       | B5       | B4       | B3       | B2       | B1       | B0       | DEFAULT |
|------|-----|----------------------|----------|----------|----------|----------|----------|----------|----------|----------|---------|
| 70h  | R/W | LED / GPIO Direction | LED8_DIR | LED7_DIR | LED6_DIR | LED5_DIR | LED4_DIR | LED3_DIR | LED2_DIR | LED1_DIR | 00h     |

The LED / GPIO Direction Register controls the data flow direction for the LED / GPIO pins. Each pin is controlled by a single bit.

Bit 7 - LED8\_DIR - Controls the direction of the LED8 / GPIO8 pin.

- '0' (default) - The LED8 / GPIO8 pin is configured as an input and cannot be used to drive an LED.
- '1' - The LED8 / GPIO8 pin is configured as an output.

Bit 6 - LED7\_DIR - Controls the direction of the LED7 / GPIO7 pin.

Bit 5 - LED6\_DIR - Controls the direction of the LED6 / GPIO6 pin.

Bit 4 - LED5\_DIR - Controls the direction of the LED5 / GPIO5 pin.

Bit 3 - LED4\_DIR - Controls the direction of the LED4 / GPIO4 pin.

Bit 2 - LED3\_DIR - Controls the direction of the LED3 / GPIO3 pin.

Bit 1 - LED2\_DIR - Controls the direction of the LED2 / GPIO2 pin.

Bit 0 - LED1\_DIR - Controls the direction of the LED1 / GPIO1 pin.

## 6.41 LED / GPIO Output Type Register

Table 6.60 LED / GPIO Output Type Register

| ADDR | R/W | REGISTER               | B7      | B6      | B5      | B4      | B3      | B2      | B1      | B0      | DEFAULT |
|------|-----|------------------------|---------|---------|---------|---------|---------|---------|---------|---------|---------|
| 71h  | R/W | LED / GPIO Output Type | LED8_OT | LED7_OT | LED6_OT | LED5_OT | LED4_OT | LED3_OT | LED2_OT | LED1_OT | 00h     |

The LED / GPIO Output Type Register controls the type of output for the LEDx / GPIOx pins that are configured to operate as outputs. Each pin is controlled by a single bit.

Bit 7 - LED8\_OT - Determines the output type of LED8.

- '0' (default) - The LED8 / GPIO8 pin is an open-drain output with an external pull-up resistor. When the appropriate bit is set to the "active" state (logic '1'), the pin will be driven low. Conversely, when the bit is set to the "inactive" state (logic '0'), the pin will be left in a high-Z state and pulled high via an external pull-up resistor.
- '1' - The LEDx / GPIO8 pin is a push-pull output. When driving a logic '1', the pin is driven high. When driving a logic '0', the pin is driven low.

Bit 6 - LED7\_OT - Determines the output type of LED7.

Bit 5 - LED6\_OT - Determines the output type of LED6.

Bit 4 - LED5\_OT - Determines the output type of LED5.

Bit 3 - LED4\_OT - Determines the output type of LED4.

Bit 2 - LED3\_OT - Determines the output type of LED3.

Bit 1 - LED2\_OT - Determines the output type of LED2.

Bit 0 - LED1\_OT - Determines the output type of LED1.

## 6.42 GPIO Input Register

Table 6.61 GPIO Input Register

| ADDR | R/W | REGISTER   | B7    | B6    | B5    | B4    | B3    | B2    | B1    | B0    | DEFAULT |
|------|-----|------------|-------|-------|-------|-------|-------|-------|-------|-------|---------|
| 72h  | R   | GPIO Input | GPIO8 | GPIO7 | GPIO6 | GPIO5 | GPIO4 | GPIO3 | GPIO2 | GPIO1 | 00h     |

The GPIO Input Register reflects the state of the LEDx / GPIOx pins. These bits are updated whenever the pin state changes regardless of the operation of the pin. If a LEDx / GPIOx pin is configured as an input (see [Section 6.40](#)), when a pin changes states, the GPIOx\_STS bit is set. If the corresponding interrupt enable bit is also set, an interrupt will be asserted.

## 6.43 LED Output Control Registers

Table 6.62 LED Output Control Registers

| ADDR | R/W | REGISTER             | B7       | B6       | B5       | B4       | B3       | B2        | B1        | B0       | DEFAULT |
|------|-----|----------------------|----------|----------|----------|----------|----------|-----------|-----------|----------|---------|
| 73h  | R/W | LED Output Control 1 | LED8_DR_ | LED7_DR_ | LED6_DR_ | LED5_DR_ | LED4_DR_ | LED3_DR_  | LED2_DR_  | LED1_DR_ | 00h     |
| 74h  | R/W | LED Output Control 2 |          |          |          |          |          | LED11_DR_ | LED10_DR_ | LED9_DR_ | 00h     |

The LED Output Control Registers control the output state of the LED pins when they are configured as outputs (see [Section 6.40, "LED / GPIO Direction Register"](#)). When these bits are set, the drive of the pin is determined by the output type and the polarity controls (see [Section 6.41, "LED / GPIO Output Type Register"](#) and [Section 6.44, "LED Polarity Registers"](#)).

The LED Polarity Control register will determine the non actuated state of the LED pins. The actuated LED behavior is determined by the LED behavior controls (see [Section , ""](#)).

### 6.43.1 LED Output Control 1

Bit 7 - LED8\_DR - Determines whether the LED8 output is driven high or low. This LED cannot be linked to a Capacitive Touch Sensor.

- '0' (default) - The LED8 output is driven at the minimum duty cycle or is not actuated.
- '1' - The LED8 output is high-Z or driven at the maximum duty cycle or is actuated.

Bit 6 - LED7\_DR - Determines whether LED7 output is driven high or low.

Bit 5 - LED6\_DR - Determines whether LED6 output is driven high or low.

Bit 4 - LED5\_DR - Determines whether LED5 output is driven high or low.

Bit 3 - LED4\_DR - Determines whether LED4 output is driven high or low.

Bit 2 - LED3\_DR - Determines whether LED3 output is driven high or low.

Bit 1 - LED2\_DR - Determines whether LED2 output is driven high or low.

Bit 0 - LED1\_DR - Determines whether LED1 output is driven high or low.

### 6.43.2 LED Output Control 2

Bit 2 - LED11\_DR - Determines whether LED11 is driven high or low. This LED cannot be linked to a Capacitive Touch Sensor.

- '0' (default) - The LED11 output is driven at the minimum duty cycle or is not actuated
- '1' - The LED11 output is high-Z or driven at the maximum duty cycle or is actuated.

Bit 1 - LED10\_DR - Determines whether LED10 is driven high or low. If this LED is linked to the Group of sensors, LED9 is automatically linked to the Group if sensors.

Bit 0 - LED9\_DR - Determines whether LED9 is driven high or low.

## 6.44 LED Polarity Registers

Table 6.63 LED Polarity Registers

| ADDR | R/W | REGISTER       | B7           | B6           | B5           | B4           | B3           | B2            | B1            | B0           | DEFAULT |
|------|-----|----------------|--------------|--------------|--------------|--------------|--------------|---------------|---------------|--------------|---------|
| 75h  | R/W | LED Polarity 1 | LED8_<br>POL | LED7_<br>POL | LED6_<br>POL | LED5_<br>POL | LED4_<br>POL | LED3_<br>POL  | LED2_<br>POL  | LED1_<br>POL | 00h     |
| 76h  | R/W | LED Polarity 2 | -            | -            | -            | -            | -            | LED11_<br>POL | LED10_<br>POL | LED9_<br>POL | 00h     |

The LED Polarity Registers control the logical polarity of the LED outputs. When these bits are set or cleared, the corresponding LED Mirror controls are also set or cleared (unless the BLK\_POL\_MIR bit is set - see [Section 6.33](#)). [Table 6.64, "LED Polarity Behavior"](#) shows the interaction between the polarity controls, output controls, and relative brightness.

**APPLICATION NOTE:** The polarity controls determine the final LED pin drive. A touch on a linked Capacitive Touch Sensor is treated in the same way as the LED Output Control bit being set to a logic '1'.

**APPLICATION NOTE:** The LED drive assumes that the LEDs are configured such that if the LED pin is driven to a logic '0', the LED will be on and the CAP1114 LED pin is sinking the LED current. Conversely, if the LED pin is driven to a logic '1', the LED will be off and there is no current flow. See [Figure 5.1, "System Diagram for CAP1114"](#).

**APPLICATION NOTE:** This application note applies when the LED polarity is inverted (LEDx\_POL = '0'). For LED operation, the duty cycle settings determine the % of time that the LED pin will be driven to a logic '0' state in an inverted system. The Max Duty Cycle settings define the maximum % of time that the LED pin will be driven low (i.e. maximum % of time that the LED is **on**) while the Min Duty Cycle settings determine the minimum % of time that the LED pin will be driven low (i.e. minimum % of time that the LED is **on**). When there is no touch detected or the LED Output Control register bit is at a logic '0', the LED output will be driven at the minimum duty cycle setting. Breathe operations will ramp the duty cycle from the minimum duty cycle to the maximum duty cycle.

**APPLICATION NOTE:** This application note applies when the LED polarity is non-inverted (LEDx\_POL = '1'). For LED operation, the duty cycle settings determine the % of time that the LED pin will be driven to a logic '1' state in a non-inverted system. The Max Duty Cycle settings define the maximum % of time that the LED pin will be driven high (i.e. maximum % of time that the LED is **off**) while the Min Duty Cycle settings determine the minimum % of time that the LED pin will be driven high (i.e. minimum % of time that the LED is **off**). When there is no touch detected or the LED Output Control register bit is at a logic '0', the LED output will be driven at 100 minus the minimum duty cycle setting. Breathe operations will ramp the duty cycle from 100 minus the minimum duty cycle to 100 minus the maximum duty cycle.

**APPLICATION NOTE:** The LED Mirror controls (see [Section 6.46, "LED Mirror Control"](#)) work with the polarity controls with respect to LED brightness but will not have a direct effect on the output pin drive.

Table 6.64 LED Polarity Behavior

| LED OUTPUT CONTROL REGISTER | POLARITY           | MAX DUTY  | MIN DUTY  | BRIGHTNESS   | LED APPEARANCE             |
|-----------------------------|--------------------|---|---|--|----------------------------|
| 0                           | inverted ('0')     | not used  | minimum % of time that the LED is on (logic 0)  | maximum brightness at min duty cycle   | on at min duty cycle       |
| 1                           | inverted ('0')     | maximum % of time that the LED is on (logic 0)  | minimum % of time that the LED is on (logic 0)  | maximum brightness at max duty cycle. Brightness ramps from min duty cycle to max duty cycle.  | according to LED behavior  |
| 0                           | non-inverted ('1') | not used  | minimum % of time that the LED is off (logic 1) | maximum brightness at 100 minus min duty cycle   | on at 100 - min duty cycle |
| 1                           | non-inverted ('1') | maximum % of time that the LED is off (logic 1) | minimum % of time that the LED is off (logic 1) | For Direct behavior, maximum brightness is 100 minus max duty cycle. When breathing, max brightness is 100 minus min duty cycle. Brightness ramps from 100 - min duty cycle to 100 - max duty cycle. | according to LED behavior  |

### 6.44.1 LED Polarity 1

Bit 7 - LED8\_POL - Determines the polarity of the LED8 output.

- '0' - The LED8 output is inverted. For example, a setting of '1' in the LED 8 Output register will cause the LED pin output to be driven to a logic '0'.
- '1' - The LED8 output is non-inverted. For example, a setting of '1' in the LED 8 Output register will cause the LED pin output to be driven to a logic '1' or left in the high-Z state as determined by its output type.

Bit 6 - LED7\_POL - Determines the polarity of the LED7 output.

Bit 5 - LED6\_POL - Determines the polarity of the LED6 output.

Bit 4 - LED5\_POL - Determines the polarity of the LED5 output.

Bit 3 - LED4\_POL - Determines the polarity of the LED4 output.

Bit 2 - LED3\_POL - Determines the polarity of the LED3 output.

Bit 1 - LED2\_POL - Determines the polarity of the LED2 output.

Bit 0 - LED1\_POL - Determines the polarity of the LED1 output.

### 6.44.2 LED Polarity 2

Bit 2 - LED11\_POL - Determines the polarity of the LED11 output.

Bit 1 - LED10\_POL - Determines the polarity of the LED10 output.

Bit 0 - LED9\_POL - Determines the polarity of the LED9 output.



## 6.45 Linked LED Transition Control Registers

Table 6.65 Linked LED Transition Control Registers

| ADDR | R/W | REGISTER                        | B7 | B6         | B5         | B4         | B3         | B2         | B1          | B0         | DEFAULT |
|------|-----|---------------------------------|----|------------|------------|------------|------------|------------|-------------|------------|---------|
| 77h  | R/W | Linked LED Transition Control 1 | -  | LED7_LTRAN | LED6_LTRAN | LED5_LTRAN | LED4_LTRAN | LED3_LTRAN | LED2_LTRAN  | LED1_LTRAN | 00h     |
| 78h  | R/W | Linked LED Transition Control 2 | -  | -          | -          | -          | -          | -          | LED10_LTRAN | LED9_LTRAN | 00h     |

The Linked LED Transition Control Registers control the LED drive when the LED is linked to a Capacitive Touch sensor. These controls work in conjunction INV\_LINK\_TRAN bit (see [Section 6.33, "Configuration 2 Register"](#)) to create smooth transitions from host control to linked LEDs.

### 6.45.1 Linked LED Transition Control 1 - 77h

Bit 6 - LED7\_LTRAN - Determines the transition effect when LED7 is linked to CS7.

- '0' (default) - When the LED output control bit for CS7 is '1', and then CS7 is linked to LED7 and no touch is detected, the LED will change states.
- '1' - If the INV\_LINK\_TRAN bit is '1', when the LED output control bit for CS7 is '1', and then CS7 is linked to LED7 and no touch is detected, the LED will not change states. In addition, the LED state will change when the sensor is touched. If the INV\_LINK\_TRAN bit is '0', when the LED output control bit for CS7 is '1', and then CS7 is linked to LED7 and no touch is detected, the LED will not change states. However, the LED state will not change when the sensor is touched.

**APPLICATION NOTE:** If the LED behavior is not "Direct" and the INV\_LINK\_TRAN bit is '0', the LED will not perform as expected when the LED7\_LTRAN bit is set to '1'. Therefore, if breathe and pulse behaviors are used, set the INV\_LINK\_TRAN bit to '1'.

Bit 5 - LED6\_LTRAN - Determines the transition effect when LED6 is linked to CS6.

Bit 4 - LED5\_LTRAN - Determines the transition effect when LED5 is linked to CS5.

Bit 3 - LED4\_LTRAN - Determines the transition effect when LED4 is linked to CS4.

Bit 2 - LED3\_LTRAN - Determines the transition effect when LED3 is linked to CS3.

Bit 1 - LED2\_LTRAN - Determines the transition effect when LED2 is linked to CS2.

Bit 0 - LED1\_LTRAN - Determines the transition effect when LED1 is linked to CS1.

### 6.45.2 Linked LED Transition Control 2 - 78h

Bit 1 - LED10\_LTRAN - Determines the transition effect when LED10 is linked to the Grouped Sensors.

Bit 0 - LED9\_LTRAN - Determines the transition effect when LED9 is linked to the Grouped Sensors.

## 6.46 LED Mirror Control

Table 6.66 LED Mirror Control Registers

| ADDR | R/W | REGISTER             | B7          | B6          | B5          | B4          | B3          | B2           | B1           | B0          | DEFAULT |
|------|-----|----------------------|-------------|-------------|-------------|-------------|-------------|--------------|--------------|-------------|---------|
| 79h  | R/W | LED Mirror Control 1 | LED8_MIR_EN | LED7_MIR_EN | LED6_MIR_EN | LED5_MIR_EN | LED4_MIR_EN | LED3_MIR_EN  | LED2_MIR_EN  | LED1_MIR_EN | 00h     |
| 7Ah  | R/W | LED Mirror Control 2 | -           | -           | -           | -           | -           | LED11_MIR_EN | LED10_MIR_EN | LED9_MIR_EN | 00h     |

The LED Mirror Control Registers determine the meaning of duty cycle settings when polarity is non-inverted for each LED channel. When the polarity bit is set to '1' (non-inverted), to obtain correct steps for LED ramping, pulse, and breathe behaviors, the min and max duty cycles need to be relative to 100%, rather than the default, which is relative to 0%.

**APPLICATION NOTE:** The LED drive assumes that the LEDs are configured such that if the LED pin is driven to a logic '0', the LED will be on and the CAP1114 LED pin is sinking the LED current. When the polarity bit is set to '1', it is considered non-inverted. For systems using the opposite LED configuration, mirror controls would apply when the polarity bit is '0'.

These bits are changed automatically if the corresponding LED Polarity bit is changed (unless the BLK\_POL\_MIR bit is set - see [Section 6.33](#)).

### 6.46.1 LED Mirror Control 1 - 79h

Bit 7 - LED8\_MIR\_EN - Determines whether the duty cycle settings are "biased" relative to 0% or 100% duty cycle.

- '0' (default) - The duty cycle settings are determined relative to 0% and are determined directly with the settings.
- '1' - The duty cycle settings are determined relative to 100%.

Bit 6 - LED7\_MIR\_EN - Determines whether the duty cycle settings are "biased" relative to 0% or 100% duty cycle.

Bit 5 - LED6\_MIR\_EN - Determines whether the duty cycle settings are "biased" relative to 0% or 100% duty cycle.

Bit 4 - LED5\_MIR\_EN - Determines whether the duty cycle settings are "biased" relative to 0% or 100% duty cycle.

Bit 3 - LED4\_MIR\_EN - Determines whether the duty cycle settings are "biased" relative to 0% or 100% duty cycle.

Bit 2 - LED3\_MIR\_EN - Determines whether the duty cycle settings are "biased" relative to 0% or 100% duty cycle.

Bit 1 - LED2\_MIR\_EN - Determines whether the duty cycle settings are "biased" relative to 0% or 100% duty cycle.

Bit 0 - LED1\_MIR\_EN - Determines whether the duty cycle settings are "biased" relative to 0% or 100% duty cycle.

## 6.46.2 LED Mirror Control 2 - 7Ah

Bit 2 - LED11\_MIR\_EN - Determines whether the duty cycle settings are “biased” relative to 0% or 100% duty cycle.

Bit 1 - LED10\_MIR\_EN - Determines whether the duty cycle settings are “biased” relative to 0% or 100% duty cycle.

Bit 0 - LED9\_MIR\_EN - Determines whether the duty cycle settings are “biased” relative to 0% or 100% duty cycle.

## 6.47 Sensor LED Linking Register

Table 6.67 Sensor LED Linking Register

| ADDR | R/W | REGISTER           | B7           | B6       | B5       | B4       | B3       | B2       | B1       | B0       | DEFAULT |
|------|-----|--------------------|--------------|----------|----------|----------|----------|----------|----------|----------|---------|
| 80h  | R/W | Sensor LED Linking | UP_DOWN_LINK | CS7_LED7 | CS6_LED6 | CS5_LED5 | CS4_LED4 | CS3_LED3 | CS2_LED2 | CS1_LED1 | 00h     |

The Sensor LED Linking Register controls whether a Capacitive Touch Sensor is linked to an LED output or not. If the corresponding bit is set, the appropriate LED output will change states defined by the LED Behavior controls (see [Section](#) ) in response to the Capacitive Touch sensor.

If the LED channel is configured as an input, the corresponding Sensor LED Linking bit is ignored.

Bit 7 - UP\_DOWN\_LINK - Links the LED10 output to a detected UP condition on the group including a slide in the “up” direction, a tap on the “up” side of the group or a press and hold condition on the “up” side of the group. The LED10 driver will be actuated and will behave as determined by the LED10\_CTL bits. This bit also links the LED9 output to a detected DOWN condition on the group including a slide in the “down” direction, a tap on the “down” side of the group or a press and hold condition on the “down” side of the group. The LED9 driver will be actuated and will behave as determined by the LED9\_CTL bits.

LED9 and LED10 will not be active simultaneously. If LED9 is actuated by detecting a slide, tap, or press and hold event, LED10 will be inactive. Likewise, if LED10 is actuated by detecting a slide, tap, or press and hold event, LED9 will be inactive.

Bit 6 - CS7\_LED7 - Links the LED7 output to a detected touch on the CS7 sensor. When a touch is detected, the LED is actuated and will behave as determined by the LED Behavior controls.

- ‘0’ - The LED7 output is not associated with the CS7 input. If a touch is detected on the CS7 input, the LED will not automatically be actuated. The LED is enabled and controlled via the LED Output Configuration register (see [Section 6.43](#)) and the LED Behavior registers (see [Section](#) ).
- ‘1’ - The LED 7 output is associated with the CS7 input. If a touch is detected on the CS7 input, the LED will be actuated and behave as defined in [Table 6.69](#). Furthermore, the LED will automatically be enabled.

Bit 5 - CS6\_LED6 - Links the LED6 output to a detected touch on the CS6 sensor. When a touch is detected, the LED is actuated and will behave as determined by the LED Behavior controls.

Bit 4 - CS5\_LED5 - Links the LED5 output to a detected touch on the CS5 sensor. When a touch is detected, the LED is actuated and will behave as determined by the LED Behavior controls.

Bit 4 - CS4\_LED4 - Links the LED4 output to a detected touch on the CS4 sensor. When a touch is detected, the LED is actuated and will behave as determined by the LED Behavior controls.

Bit 2 - CS3\_LED3 - Links the LED3 output to a detected touch on the CS3 sensor. When a touch is detected, the LED is actuated and will behave as determined by the LED Behavior controls.

**Datasheet**

Bit 1 - CS2\_LED2 - Links the LED2 output to a detected touch on the CS2 sensor. When a touch is detected, the LED is actuated and will behave as determined by the LED Behavior controls.

Bit 0 - CS1\_LED1 - Links the LED1 output to a detected touch on the CS1 sensor. When a touch is detected, the LED is actuated and will behave as determined by the LED Behavior controls.

## 6.48 LED Behavior Registers

**Table 6.68 LED Behavior Registers**

| ADDR | R/W | REGISTER       | B7              | B6 | B5              | B4 | B3              | B2 | B1            | B0 | DEFAULT |
|------|-----|----------------|-----------------|----|-----------------|----|-----------------|----|---------------|----|---------|
| 81h  | R/W | LED Behavior 1 | LED4_CTL[1:0]   |    | LED3_CTL[1:0]   |    | LED2_CTL[1:0]   |    | LED1_CTL[1:0] |    | 00h     |
| 82h  | R/W | LED Behavior 2 | LED8_CTL[1:0]   |    | LED7_CTL[1:0]   |    | LED6_CTL[1:0]   |    | LED5_CTL[1:0] |    | 00h     |
| 83h  | R/W | LED Behavior 3 | LED11_ALT [1:0] |    | LED11_CTL [1:0] |    | LED10_CTL [1:0] |    | LED9_CTL[1:0] |    | 00h     |

The LED Behavior Registers control the operation of LEDs. Each LEDx / GPIOx pin is controlled by a 2-bit field. If the LEDx / GPIOx pin is configured as an input, these bits are ignored.

If the corresponding LED output is linked to a Capacitive Touch Sensor, the appropriate behavior will be enabled / disabled based on touches and releases.

If the LED output is not associated with a Capacitive Touch Sensor, the appropriate behavior will be enabled / disabled by the LED Output Control register. If the respective LEDx\_DR bit is set to a logic '1', this will be associated as a "touch", and if the LEDx\_DR bit is set to a logic '0', this will be associated as a "release".

[Table 6.69](#) shows the behavior triggers. The defined behavior will activate when the Start Trigger is met and will stop when the Stop Trigger is met. Note the behavior of the Breathe Hold and Pulse Release option.

The LED Polarity Control register will determine the non actuated state of the LED outputs (see [Section 6.44, "LED Polarity Registers"](#)).

**APPLICATION NOTE:** If an LED is not linked to a Capacitive Touch Sensor and is breathing (via the Breathe or Pulse behaviors), it must be unactuated before any changes to behavior are processed.

**APPLICATION NOTE:** If an LED is not linked to the Capacitive Touch Sensor and configured to operate using Pulse 1 Behavior, the circuitry will only be actuated when the corresponding bit is set. It will not check the bit condition until the Pulse 1 behavior is finished. The device will not remember if the bit was cleared and reset while it was actuated.

**APPLICATION NOTE:** If an LED is actuated and it is switched from linked to a Capacitive Touch Sensor to unlinked (or vice versa), the LED will respond to the new command source immediately if the behavior was Direct or Breathe. For Pulse behaviors, it will complete the behavior already in progress. For example, if a linked LED was actuated by a touch and the control is changed so that it is unlinked, it will check the status of the corresponding LED Output Control bit. If that bit is '0', the LED will behave as if a release was detected. Likewise, if an unlinked LED was actuated by the LED Output Control register and the control is changed so that it is linked and no touch is detected, the LED will behave as if a release was detected.

### 6.48.1 LED Behavior 1 - 81h

Bits 7 - 6 - LED4\_CTL[1:0] - Determines the behavior of LED4 / GPIO4 when configured to operate as an LED output.

Bits 5 - 4 - LED3\_CTL[1:0] - Determines the behavior of LED3 / GPIO3 when configured to operate as an LED output.

Bits 3 - 2 - LED2\_CTL[1:0] - Determines the behavior of LED2 / GPIO2 when configured to operate as an LED output.

Bits 1 - 0 - LED1\_CTL[1:0] - Determines the behavior of LED1 / GPIO1 when configured to operate as an LED output.

## 6.48.2 LED Behavior 2 - 82h

Bits 7 - 6 - LED8\_CTL[1:0] - Determines the behavior of LED8 / GPIO8 when configured to operate as an LED output.

Bits 5 - 4 - LED7\_CTL[1:0] - Determines the behavior of LED7 / GPIO7 when configured to operate as an LED output.

Bits 3 - 2 - LED6\_CTL[1:0] - Determines the behavior of LED6 / GPIO6 when configured to operate as an LED output.

Bits 1 - 0 - LED5\_CTL[1:0] - Determines the behavior of LED5 / GPIO5 when configured to operate as an LED output.

## 6.48.3 LED Behavior 3 - 83h

Bits 7 - 6 - LED11\_ALT[1:0] - Determines the behavior of LED 11 when the PWR\_LED bit is set and either the SLEEP or DSLEEP bits are set (see [Section 6.1](#)).

Bits 5 - 4 - LED11\_CTL[1:0] - Determines the behavior of LED11 when the PWR\_LED bit is set and both the SLEEP and DSLEEP bits are not set (see [Section 6.1](#)).

Bits 3 - 2 - LED10\_CTL[1:0] - Determines the behavior of LED10.

Bits 1 - 0 - LED9\_CTL[1:0] - Determines the behavior of LED9.

**APPLICATION NOTE:** When driving the LED / GPIOx output as a GPO, the LEDx\_CTL[1:0] bits should be set to 00b.

**Table 6.69 LEDx\_CTL Bit Decode**

| LEDX_CTL<br>[1:0] |   | OPERATION | DESCRIPTION   | START<br>TRIGGER   | STOP<br>TRIGGER                                    |
|-------------------|---|-----------|---|--|--|
| 1                 | 0 |           |   |  |  |
| 0                 | 0 | Direct    | The LED is driven to the programmed state (active or inactive). See <a href="#">Figure 6.5</a>  | Touch Detected or LED Output Control bit set   | Release Detected or LED Output Control bit cleared |
| 0                 | 1 | Pulse 1   | The LED will “Pulse” a programmed number of times. During each “Pulse” the LED will breathe up to the maximum brightness and back down to the minimum brightness so that the total “Pulse” period matches the programmed value. | Touch or Release Detected or LED Output Control bit set or cleared (see <a href="#">Section 6.49</a> ) | n/a  |

Table 6.69 LEDx\_CTL Bit Decode (continued)

| LEDX_CTL [1:0] |   | OPERATION | DESCRIPTION  | START TRIGGER                                | STOP TRIGGER                                       |
|----------------|---|-----------|--|--|--|
| 1              | 0 |           |  |  |  |
| 1              | 0 | Pulse 2   | The LED will “Pulse” when the start trigger is detected. When the stop trigger is detected, it will “Pulse” a programmable number of times then return to its minimum brightness.  | Touch Detected or LED Output Control bit set | Release Detected or LED Output Control bit cleared |
| 1              | 1 | Breathe   | The LED will breathe. It will be driven with a duty cycle that ramps up from the programmed minimum duty cycle (default 0%) to the programmed maximum duty cycle (default 100%) and then back down. Each ramp takes up 50% of the programmed period. The total period of each “breath” is determined by the LED Breathe Period controls - see <a href="#">Section 6.51</a> . | Touch Detected or LED Output Control bit set | Release Detected or LED Control Output bit cleared |

**APPLICATION NOTE:** The PWM frequency is determined based on the selected LED behavior, the programmed breathe period, and the programmed min and max duty cycles. For the Direct behavior mode, the PWM frequency is calculated based on the programmed Rise and Fall times. If these are set at 0, the maximum PWM frequency will be used based on the programmed duty cycle settings.

## 6.49 LED Pulse 1 Period Register

Table 6.70 LED Pulse 1 Period Register

| ADDR | R/W | REGISTER           | B7      | B6      | B5      | B4      | B3      | B2      | B1      | B0      | DEFAULT |
|------|-----|--------------------|---------|---------|---------|---------|---------|---------|---------|---------|---------|
| 84h  | R/W | LED Pulse 1 Period | ST_TRIG | P1_PER6 | P1_PER5 | P1_PER4 | P1_PER3 | P1_PER2 | P1_PER1 | P1_PER0 | 20h     |

The LED Pulse 1 Period Register determines the overall period of a pulse operation as determined by the LED\_CTL registers (see [Table 6.69](#) - setting 01b). Each LSB represents 32ms so that a setting of 14h (20d) would represent a period of 640ms. The total range is from 32ms to 4.06 seconds as shown in [Table 6.71](#).

The number of pulses is programmable as determined by the PULSE1\_CNT bits (see [Section 6.52](#)).

Bit 7 - ST\_TRIG - Determines the start trigger for the LED Pulse behavior.

- '0' (default) - The LED will Pulse when a touch is detected or the drive bit is set.
- '1' - The LED will Pulse when a release is detected or the drive bit is cleared.

The Pulse 1 operation is shown in [Figure 6.1](#) (non-inverted polarity LEDx\_POL = 1) and [Figure 6.2](#) (inverted polarity LEDx\_POL = 0).

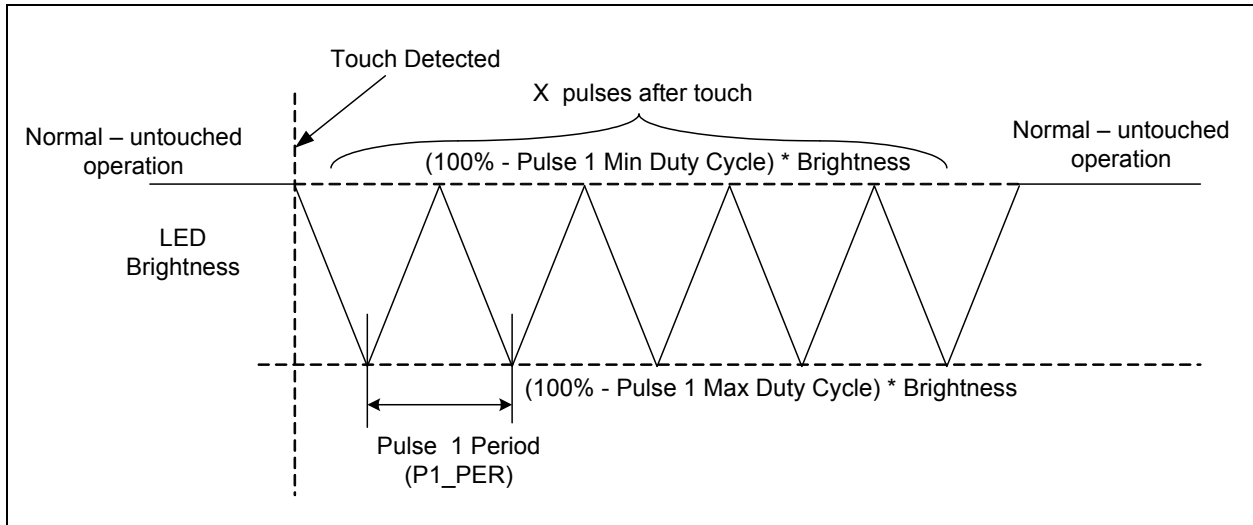

Figure 6.1 Pulse 1 Behavior with Touch Trigger and Non-inverted Polarity

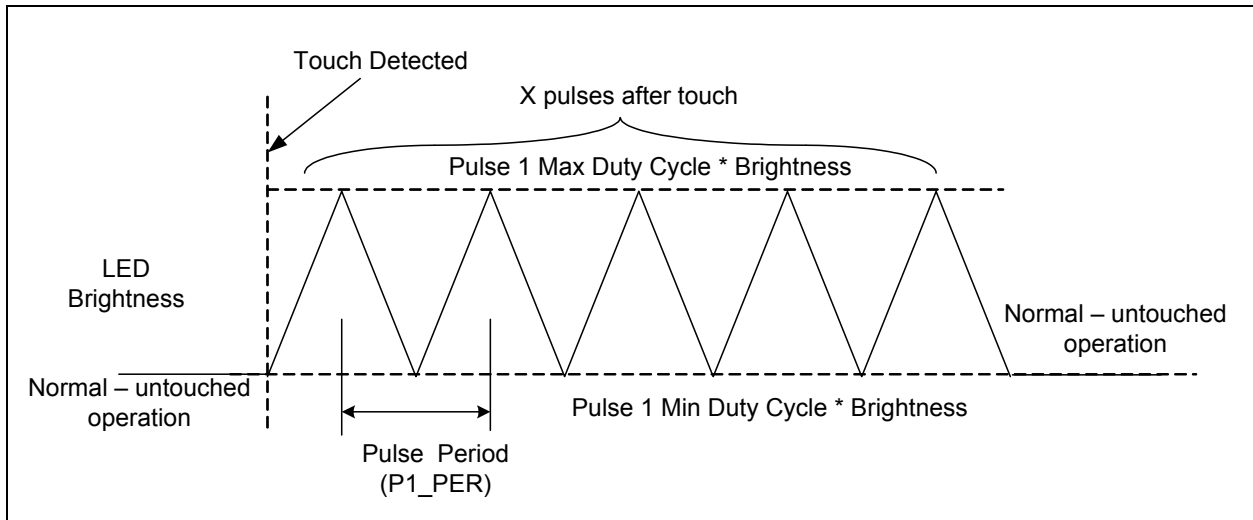

Figure 6.2 Pulse 1 Behavior with Touch Trigger and Inverted Polarity

Table 6.71 LED Pulse / Breathe Period Example

| SETTING (HEX) | SETTING (DECIMAL) | TOTAL PULSE / BREATHE PERIOD (ms) |
|---------------|-------------------|-----------------------------------|
| 00h           | 0                 | 32                                |
| 01h           | 1                 | 32                                |
| 02h           | 2                 | 64                                |
| 03h           | 3                 | 96                                |
| 04h           | 4                 | 128                               |

Table 6.71 LED Pulse / Breathe Period Example (continued)

| SETTING (HEX) | SETTING (DECIMAL) | TOTAL PULSE / BREATHE PERIOD (ms) |
|---------------|-------------------|-----------------------------------|
| ...           | ...               | ...                               |
| 7Ch           | 124               | 3,968                             |
| 7Dh           | 125               | 4,000                             |
| 7Eh           | 126               | 4,032                             |
| 7Fh           | 127               | 4.064                             |

## 6.50 LED Pulse 2 Period Register

Table 6.72 LED Pulse 2 Period Register

| ADDR | R/W | REGISTER           | B7 | B6      | B5      | B4      | B3      | B2      | B1      | B0      | DEFAULT |
|------|-----|--------------------|----|---------|---------|---------|---------|---------|---------|---------|---------|
| 85h  | R/W | LED Pulse 2 Period | -  | P2_PER6 | P2_PER5 | P2_PER4 | P2_PER3 | P2_PER2 | P2_PER1 | P2_PER0 | 14h     |

The LED Pulse 2 Period Register determines the overall period of a pulse operation as determined by the LED\_CTL registers (see Table 6.69 - setting 10b). Each LSB represents 32ms so that a setting of 14h (20d) would represent a period of 640ms. The total range is from 32ms to 4.06 seconds (see Table 6.71).

The number of pulses is programmable as determined by the PULSE2\_CNT bits (see Section 6.52).

The Pulse 2 Behavior is shown in Figure 6.3 (non-inverted polarity LEDx\_POL = 1) and Figure 6.4 (inverted polarity LEDx\_POL = 0).

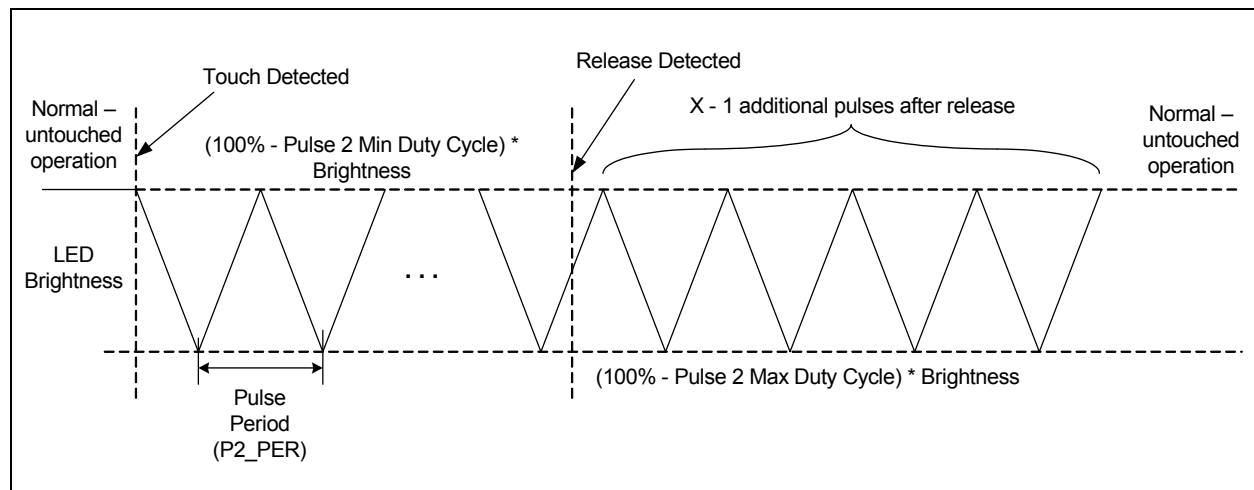

Figure 6.3 Pulse 2 Behavior with Non-Inverted Polarity



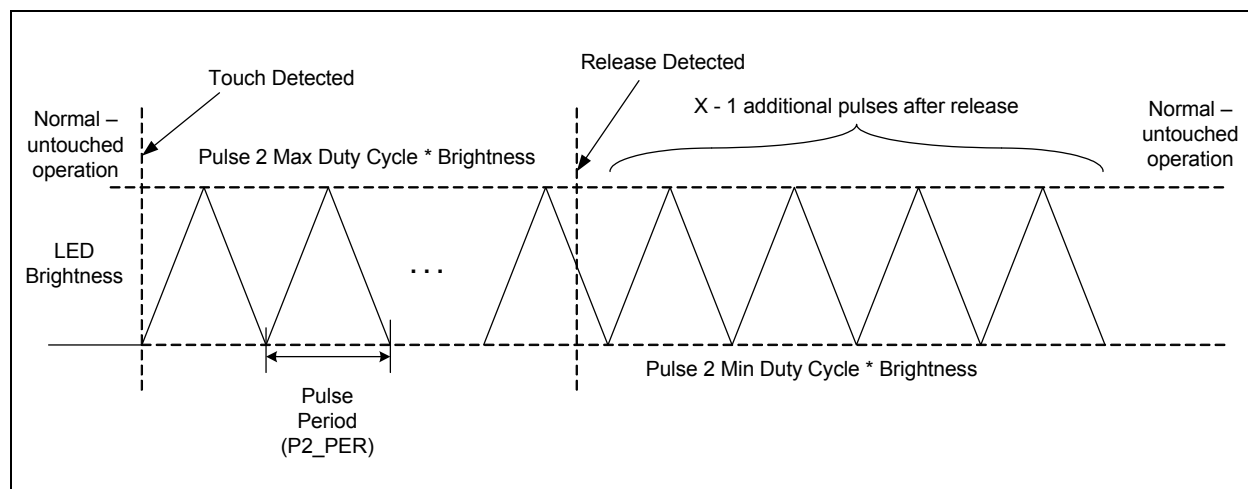

Figure 6.4 Pulse 2 Behavior with Inverted Polarity

## 6.51 LED Breathe Period Register

Table 6.73 LED Breathe Period Register

| ADDR | R/W | REGISTER           | B7 | B6      | B5      | B4      | B3      | B2      | B1      | B0      | DEFAULT |
|------|-----|--------------------|----|---------|---------|---------|---------|---------|---------|---------|---------|
| 86h  | R/W | LED Breathe Period | -  | BR_PER6 | BR_PER5 | BR_PER4 | BR_PER3 | BR_PER2 | BR_PER1 | BR_PER0 | 5Dh     |

The LED Breathe Period Register determines the overall period of a breathe operation as determined by the LED\_CTL registers (see Table 6.69 - setting 11b). Each LSB represents 32ms so that a setting of 14h (20d) would represent a period of 640ms. The total range is from 32ms to 4.06 seconds (see Table 6.71).

## 6.52 LED Configuration Register

Table 6.74 LED Configuration Registers

| ADDR | R/W | REGISTER   | B7 | B6         | B5              | B4 | B3 | B2              | B1 | B0 | DEFAULT |
|------|-----|------------|----|------------|-----------------|----|----|-----------------|----|----|---------|
| 88h  | R/W | LED Config | -  | RAMP_ALERT | PULSE2_CNT[2:0] |    |    | PULSE1_CNT[2:0] |    |    | 24h     |

The LED Configuration Register controls the number of pulses that are sent for the Pulse 1 and Pulse 2 LED output behaviors.

Bit 6 - RAMP\_ALERT - Determines whether the device will assert the ALERT pin when LEDs actuated by the LED Output Control register bits have finished their respective behaviors.

- '0' (default) - The ALERT pin will not be asserted when LEDs actuated by the LED Output Control register have finished their programmed behaviors.
- '1' - The ALERT pin will be asserted whenever any LED that is actuated by the LED Output Control register has finished its programmed behavior. If the DSLEEP bit is set, this bit is cleared.

## Datasheet

Bits 5 - 3 - PULSE2\_CNT[2:0] - Determines the number of pulses used for the Pulse 2 behavior as shown in [Table 6.75](#). The default is 100b.

Bits 2 - 0 - PULSE1\_CNT[2:0] - Determines the number of pulses used for the Pulse 1 behavior as shown in [Table 6.75](#).

Table 6.75 PULSE\_CNT Decode

| PULSEX_CNT[2:0] |   |   | NUMBER OF BREATHS |
|-----------------|---|---|-------------------|
| 2               | 1 | 0 |                   |
| 0               | 0 | 0 | 1                 |
| 0               | 0 | 1 | 2                 |
| 0               | 1 | 0 | 3                 |
| 0               | 1 | 1 | 4                 |
| 1               | 0 | 0 | 5 (default)       |
| 1               | 0 | 1 | 6                 |
| 1               | 1 | 0 | 7                 |
| 1               | 1 | 1 | 8                 |

## 6.53 LED Pulse and Breathe Duty Cycle Registers

Table 6.76 LED Period and Breathe Duty Cycle Registers

| ADDR | R/W | REGISTER               | B7                   | B6 | B5 | B4 | B3                   | B2 | B1 | B0 | DEFAULT |
|------|-----|------------------------|----------------------|----|----|----|----------------------|----|----|----|---------|
| 90h  | R/W | LED Pulse 1 Duty Cycle | LED_P1_MAX_DUTY[3:0] |    |    |    | LED_P1_MIN_DUTY[3:0] |    |    |    | F0h     |
| 91h  | R/W | LED Pulse 2 Duty cycle | LED_P2_MAX_DUTY[3:0] |    |    |    | LED_P2_MIN_DUTY[3:0] |    |    |    | F0h     |
| 92h  | R/W | LED Breathe Duty Cycle | LED_BR_MAX_DUTY[3:0] |    |    |    | LED_BR_MIN_DUTY[3:0] |    |    |    | F0h     |
| 93h  | R/W | Direct Duty Cycle      | LED_DR_MAX_DUTY[3:0] |    |    |    | LED_DR_MIN_DUTY[3:0] |    |    |    | F0h     |

The LED Pulse and Breathe Duty Cycle Registers determine the minimum and maximum duty cycle settings used for the LED for each LED behavior. These settings affect the brightness of the LED when it is fully off and fully on.

The LED driver duty cycle will ramp up from the minimum duty cycle to the maximum duty cycle and back down again.

**APPLICATION NOTE:** When operating in Direct behavior mode, changes to the Duty Cycle settings will be applied immediately. When operating in Breathe, Pulse 1, or Pulse 2 modes, the LED must be unactuated and then re-actuated before changes to behavior are processed.

Bits 7 - 4 - LED\_X\_MAX\_DUTY[3:0] - Determines the maximum PWM duty cycle for the LED drivers as shown in [Table 6.77](#).

Bits 3 - 0 - LED\_X\_MIN\_DUTY[3:0] - Determines the minimum PWM duty cycle for the LED drivers as shown in [Table 6.77](#).

Table 6.77 LED Duty Cycle Decode

| X_MAX/MIN_DUTY [3:0] |   |   |   | MAXIMUM DUTY CYCLE | MINIMUM DUTY CYCLE |
|----------------------|---|---|---|--------------------|--------------------|
| 3                    | 2 | 1 | 0 |                    |                    |
| 0                    | 0 | 0 | 0 | 7%                 | 0%                 |
| 0                    | 0 | 0 | 1 | 9%                 | 7%                 |
| 0                    | 0 | 1 | 0 | 11%                | 9%                 |
| 0                    | 0 | 1 | 1 | 14%                | 11%                |
| 0                    | 1 | 0 | 0 | 17%                | 14%                |
| 0                    | 1 | 0 | 1 | 20%                | 17%                |
| 0                    | 1 | 1 | 0 | 23%                | 20%                |
| 0                    | 1 | 1 | 1 | 26%                | 23%                |
| 1                    | 0 | 0 | 0 | 30%                | 26%                |
| 1                    | 0 | 0 | 1 | 35%                | 30%                |
| 1                    | 0 | 1 | 0 | 40%                | 35%                |
| 1                    | 0 | 1 | 1 | 46%                | 40%                |
| 1                    | 1 | 0 | 0 | 53%                | 46%                |
| 1                    | 1 | 0 | 1 | 63%                | 53%                |
| 1                    | 1 | 1 | 0 | 77%                | 63%                |
| 1                    | 1 | 1 | 1 | 100%               | 77%                |

## 6.54 LED Direct Ramp Rates Register

Table 6.78 LED Direct Ramp Rates Register

| ADDR | R/W | REGISTER              | B7 | B6 | B5             | B4 | B3 | B2             | B1 | B0 | DEFAULT |
|------|-----|-----------------------|----|----|----------------|----|----|----------------|----|----|---------|
| 94h  | R/W | LED Direct Ramp Rates | -  | -  | RISE_RATE[2:0] |    |    | FALL_RATE[2:0] |    |    | 00h     |

The LED Direct Ramp Rates Register control the rising and falling edge time of an LED that is configured to operate in Direct behavior mode. The rising edge time corresponds to the amount of time the LED takes to transition from its minimum duty cycle to its maximum duty cycle. Conversely, the falling edge time corresponds to the amount of time that the LED takes to transition from its maximum duty cycle to its minimum duty cycle.

Bits 5 - 3 - RISE\_RATE[2:0] - Determines the rising edge time of an LED when it transitions from its minimum drive state to its maximum drive state as shown in [Table 6.79](#).

## Datasheet

**APPLICATION NOTE:** If a non-zero fall time is desired, the rise rate must be set to be equal to the desired fall rate. This should be done as a register write after the LED has been actuated and before it is unactuated.

Bits 2 - 0 - FALL\_RATE[2:0] - Determines the falling edge time of an LED when it transitions from its maximum drive state to its minimum drive state as shown in [Table 6.79](#).

Table 6.79 Rise / Fall Rate Cycle Decode

| RISE/FALL_RATE [2:0] |   |   | RISE / FALL TIME ( $T_{RISE}$ / $T_{FALL}$ ) |
|----------------------|---|---|--|
| 2                    | 1 | 0 |  |
| 0                    | 0 | 0 | 0  |
| 0                    | 0 | 1 | 250ms  |
| 0                    | 1 | 0 | 500ms  |
| 0                    | 1 | 1 | 750ms  |
| 1                    | 0 | 0 | 1s   |
| 1                    | 0 | 1 | 1.25s  |
| 1                    | 1 | 0 | 1.5s   |
| 1                    | 1 | 1 | 2s   |

## 6.55 LED Off Delay Register

Table 6.80 LED Off Delay Register

| ADDR | R/W | REGISTER               | B7 | B6 | B5 | B4 | B3 | B2                | B1 | B0 | DEFAULT |
|------|-----|------------------------|----|----|----|----|----|-------------------|----|----|---------|
| 95h  | R/W | LED Off Delay Register | -  | -  | -  | -  | -  | DIR_OFF_DLY [2:0] |    |    | 00h     |

The LED Off Delay Register determines the amount of time an LED in Direct behavior mode remains active after it is no longer actuated (such as after a release has been detected or the drive state has been changed).

Bits 2 - 0 - DIR\_OFF\_DLY[2:0] - Determines the turn-off delay, as shown in [Table 6.81](#), for all LEDs that are configured to operate in Direct behavior mode.

Table 6.81 Off Delay Settings

| DIR_OFF_DLY [2:0] |   |   | OFF DELAY<br>$T_{OFF\_DLY}$ |
|-------------------|---|---|-----------------------------|
| 2                 | 1 | 0 |                             |
| 0                 | 0 | 0 | 0                           |
| 0                 | 0 | 1 | 0.5s                        |
| 0                 | 1 | 0 | 1.0s                        |
| 0                 | 1 | 1 | 1.5s                        |

Table 6.81 Off Delay Settings (continued)

| DIR_OFF_DLY [2:0] |   |   | OFF DELAY<br>$T_{OFF\_DLY}$ |
|-------------------|---|---|-----------------------------|
| 2                 | 1 | 0 |                             |
| 1                 | 0 | 0 | 2.0s                        |
| 1                 | 0 | 1 | 3.0s                        |
| 1                 | 1 | 0 | 4.0s                        |
| 1                 | 1 | 1 | 5.0s                        |

The Direct behavior operation is shown determined by the combination of programmed Rise Time, Fall Time, and Off Delay as shown in Figure 6.5 (non-inverted polarity LEDx\_POL = 1) and Figure 6.6 (inverted polarity LEDx\_POL = 0).

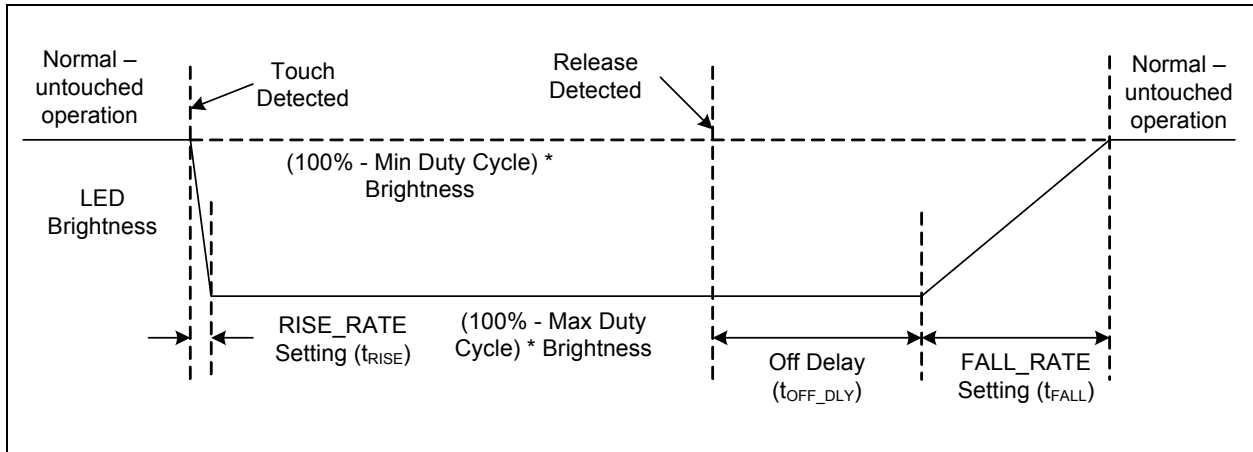

Figure 6.5 Direct Behavior for Non-Inverted Polarity

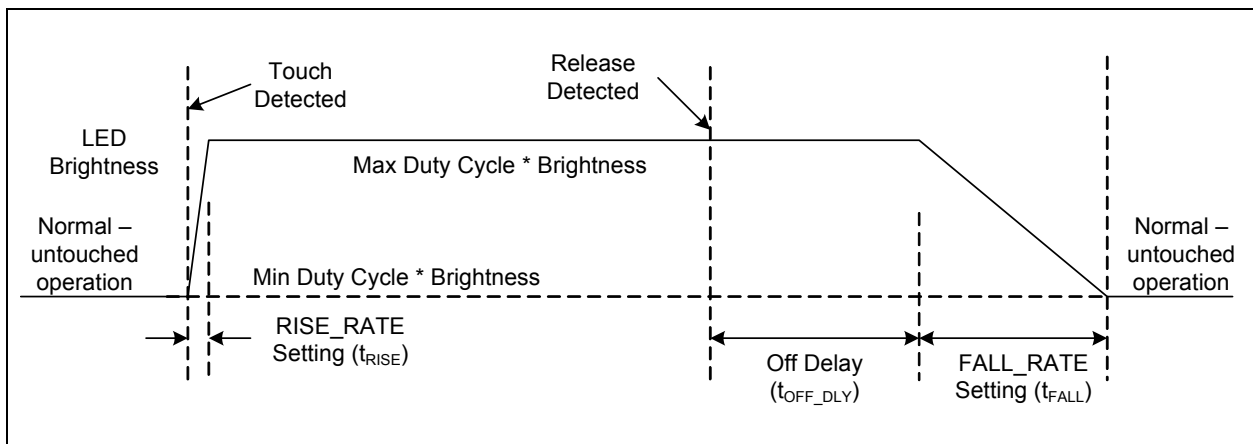

Figure 6.6 Direct Behavior for Inverted Polarity

## 6.56 Sensor Calibration Registers

Table 6.82 Sensor Calibration Registers

| ADDR | REGISTER                       | R/W | B7      | B6      | B5      | B4      | B3      | B2      | B1      | B0      | DEFAULT |
|------|--------------------------------|-----|---------|---------|---------|---------|---------|---------|---------|---------|---------|
| B1h  | Sensor 1 Calibration           | R   | CAL1_9  | CAL1_8  | CAL1_7  | CAL1_6  | CAL1_5  | CAL1_4  | CAL1_3  | CAL1_2  | 00h     |
| B2h  | Sensor 2 Calibration           | R   | CAL2_9  | CAL2_8  | CAL2_7  | CAL2_6  | CAL2_5  | CAL2_4  | CAL2_3  | CAL2_2  | 00h     |
| B3h  | Sensor 3 Calibration           | R   | CAL3_9  | CAL3_8  | CAL3_7  | CAL3_6  | CAL3_5  | CAL3_4  | CAL3_3  | CAL3_2  | 00h     |
| B4h  | Sensor 4 Calibration           | R   | CAL4_9  | CAL4_8  | CAL4_7  | CAL4_6  | CAL4_5  | CAL4_4  | CAL4_3  | CAL4_2  | 00h     |
| B5h  | Sensor 5 Calibration           | R   | CAL5_9  | CAL5_8  | CAL5_7  | CAL5_6  | CAL5_5  | CAL5_4  | CAL5_3  | CAL5_2  | 00h     |
| B6h  | Sensor 6 Calibration           | R   | CAL6_9  | CAL6_8  | CAL6_7  | CAL6_6  | CAL6_5  | CAL6_4  | CAL6_3  | CAL6_2  | 00h     |
| B7h  | Sensor 7 Calibration           | R   | CAL7_9  | CAL7_8  | CAL7_7  | CAL7_6  | CAL7_5  | CAL7_4  | CAL7_3  | CAL7_2  | 00h     |
| B8h  | Sensor 8 Calibration           | R   | CAL8_9  | CAL8_8  | CAL8_7  | CAL8_6  | CAL8_5  | CAL8_4  | CAL8_3  | CAL8_2  | 00h     |
| B9h  | Sensor 9 Calibration           | R   | CAL9_9  | CAL9_8  | CAL9_7  | CAL9_6  | CAL9_5  | CAL9_4  | CAL9_3  | CAL9_2  | 00h     |
| BAh  | Sensor 10 Calibration          | R   | CAL10_9 | CAL10_8 | CAL10_7 | CAL10_6 | CAL10_5 | CAL10_4 | CAL10_3 | CAL10_2 | 00h     |
| BBh  | Sensor 11 Calibration          | R   | CAL11_9 | CAL11_8 | CAL11_7 | CAL11_6 | CAL11_5 | CAL11_4 | CAL11_3 | CAL11_2 | 00h     |
| BCh  | Sensor 12 Calibration          | R   | CAL12_9 | CAL12_8 | CAL12_7 | CAL12_6 | CAL12_5 | CAL12_4 | CAL12_3 | CAL12_2 | 00h     |
| BDh  | Sensor 13 Calibration          | R   | CAL13_9 | CAL13_8 | CAL13_7 | CAL13_6 | CAL13_5 | CAL13_4 | CAL13_3 | CAL13_2 | 00h     |
| BEh  | Sensor 14 Calibration          | R   | CAL14_9 | CAL14_8 | CAL14_7 | CAL14_6 | CAL14_5 | CAL14_4 | CAL14_3 | CAL14_2 | 00h     |
| D0h  | Sensor 1 Calibration Low byte  | R   | CAL4_1  | CAL4_0  | CAL3_1  | CAL3_0  | CAL2_1  | CAL2_0  | CAL1_1  | CAL1_0  | 00h     |
| D1h  | Sensor 5 Calibration Low byte  | R   | CAL8_1  | CAL8_0  | CAL7_1  | CAL7_0  | CAL6_1  | CAL6_0  | CAL5_1  | CAL5_0  | 00h     |
| D2h  | Sensor 9 Calibration Low byte  | R   | CAL12_1 | CAL12_0 | CAL11_1 | CAL11_0 | CAL10_1 | CAL10_0 | CAL9_1  | CAL9_0  | 00h     |
| D3h  | Sensor 13 Calibration Low byte | R   | -       | -       | -       | -       | CAL14_1 | CAL14_0 | CAL13_1 | CAL13_0 | 00h     |

The Sensor Calibration Registers hold the 10-bit value that is used for the analog block when each sensor is selected. These registers are read only. They are updated automatically by the digital block when the analog re-calibration routine is performed.

These bits are cleared when the device is placed into Standby or Deep Sleep for all channels that are not sampled.

## 6.57 Product ID Register

Table 6.83 Product ID Register

| ADDR | R/W | REGISTER   | B7 | B6 | B5 | B4 | B3 | B2 | B1 | B0 | DEFAULT |
|------|-----|------------|----|----|----|----|----|----|----|----|---------|
| FDh  | R   | Product ID | 0  | 0  | 1  | 1  | 1  | 0  | 1  | 0  | 3Ah     |

The Product ID Register stores a unique 8-bit value that identifies the device.

## 6.58 Revision Register

Table 6.84 Revision Register

| ADDR | R/W | REGISTER | B7 | B6 | B5 | B4 | B3 | B2 | B1 | B0 | DEFAULT |
|------|-----|----------|----|----|----|----|----|----|----|----|---------|
| FFh  | R   | Revision | 1  | 0  | 0  | 0  | 0  | 0  | 0  | 0  | 80h     |

The Revision Register stores an 8-bit value that represents the part revision.

# Chapter 7 Package Information

## 7.1 Package Drawings

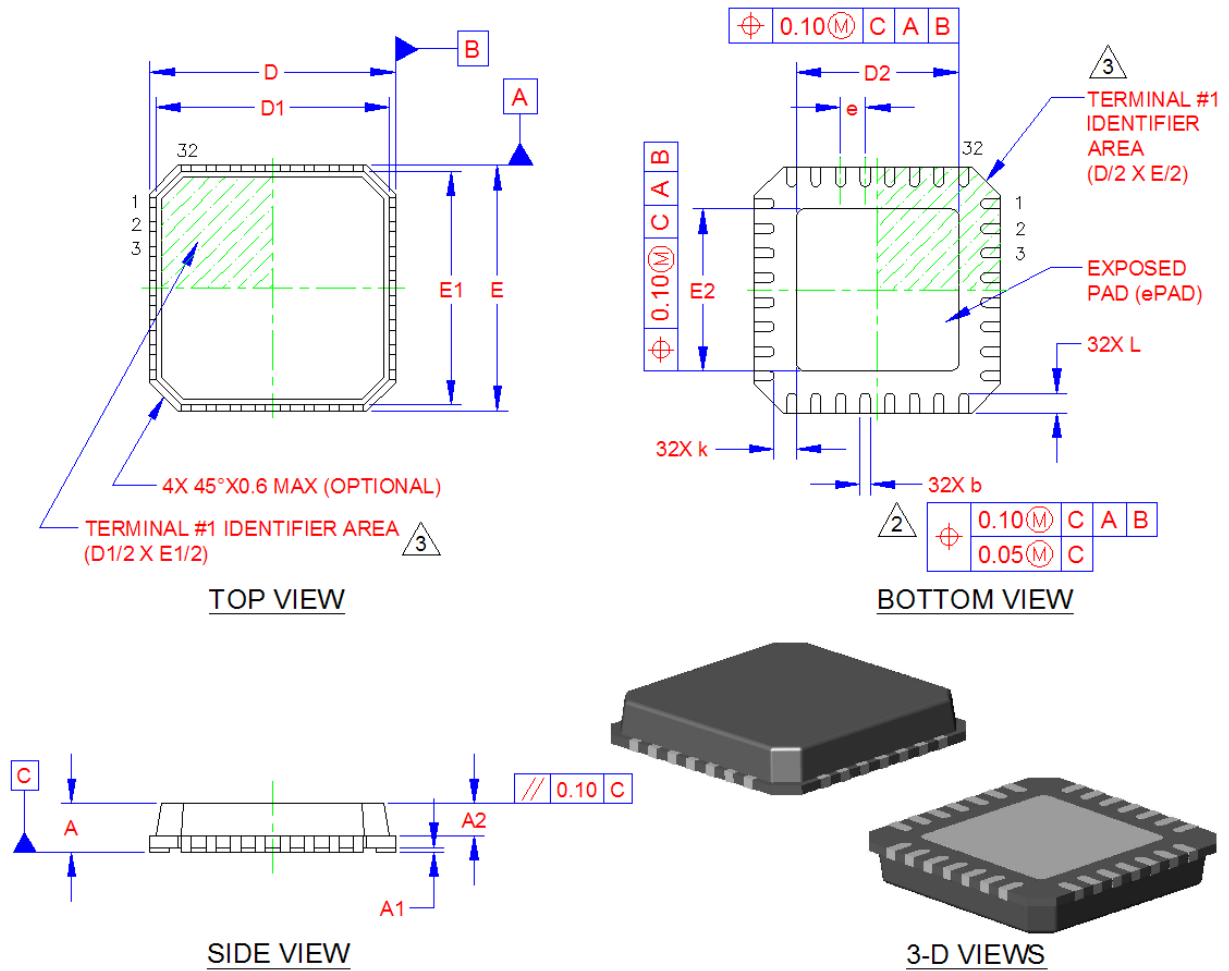

Figure 7.1 Package Diagram - 32-Pin QFN



| COMMON DIMENSIONS |          |      |      |      |                            |
|-------------------|----------|------|------|------|----------------------------|
| SYMBOL            | MIN      | NOM  | MAX  | NOTE | REMARK                     |
| A                 | 0.70     | 0.85 | 1.00 | -    | OVERALL PACKAGE HEIGHT     |
| A1                | 0        | 0.02 | 0.05 | -    | STANDOFF                   |
| A2                | -        | -    | 0.90 | -    | MOLD CAP THICKNESS         |
| D/E               | 4.90     | 5.00 | 5.10 | -    | X/Y BODY SIZE              |
| D1/E1             | 4.55     | 4.75 | 4.95 | -    | X/Y MOLD CAP SIZE          |
| D2/E2             | 3.10     | 3.30 | 3.40 | -    | X/Y EXPOSED PAD SIZE       |
| L                 | 0.30     | 0.40 | 0.50 | -    | TERMINAL LENGTH            |
| b                 | 0.18     | 0.25 | 0.30 | 2    | TERMINAL WIDTH             |
| k                 | 0.35     | -    | -    | -    | TERMINAL TO ePAD CLEARANCE |
| e                 | 0.50 BSC |      |      | -    | TERMINAL PITCH             |

**NOTES:**

1. ALL DIMENSIONS ARE IN MILLIMETERS.
2. DIMENSIONS "b" APPLIES TO PLATED TERMINALS AND IT IS MEASURED BETWEEN 0.15 AND 0.30 mm FROM THE TERMINAL TIP.
3. DETAILS OF TERMINAL #1 IDENTIFIER ARE OPTIONAL BUT MUST BE LOCATED WITHIN THE AREA INDICATED.

Figure 7.2 Package Dimensions - 32-Pin QFN

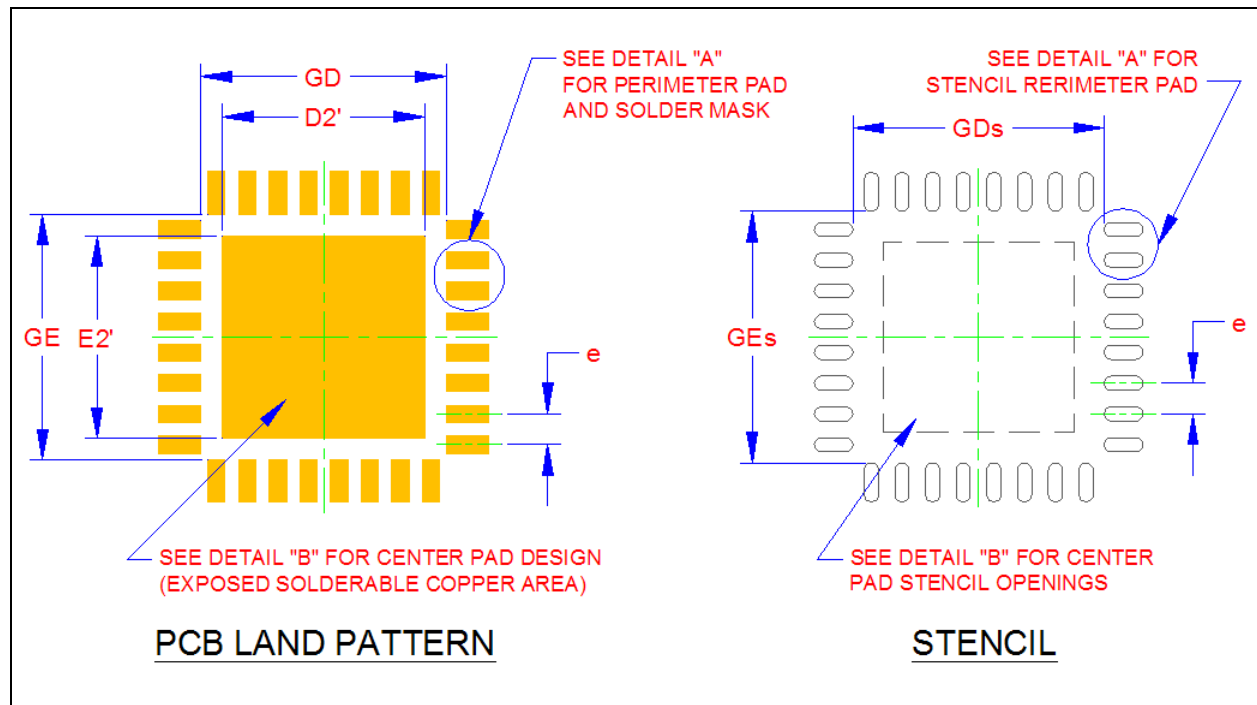

Figure 7.3 Package PCB Land Pattern and Stencil

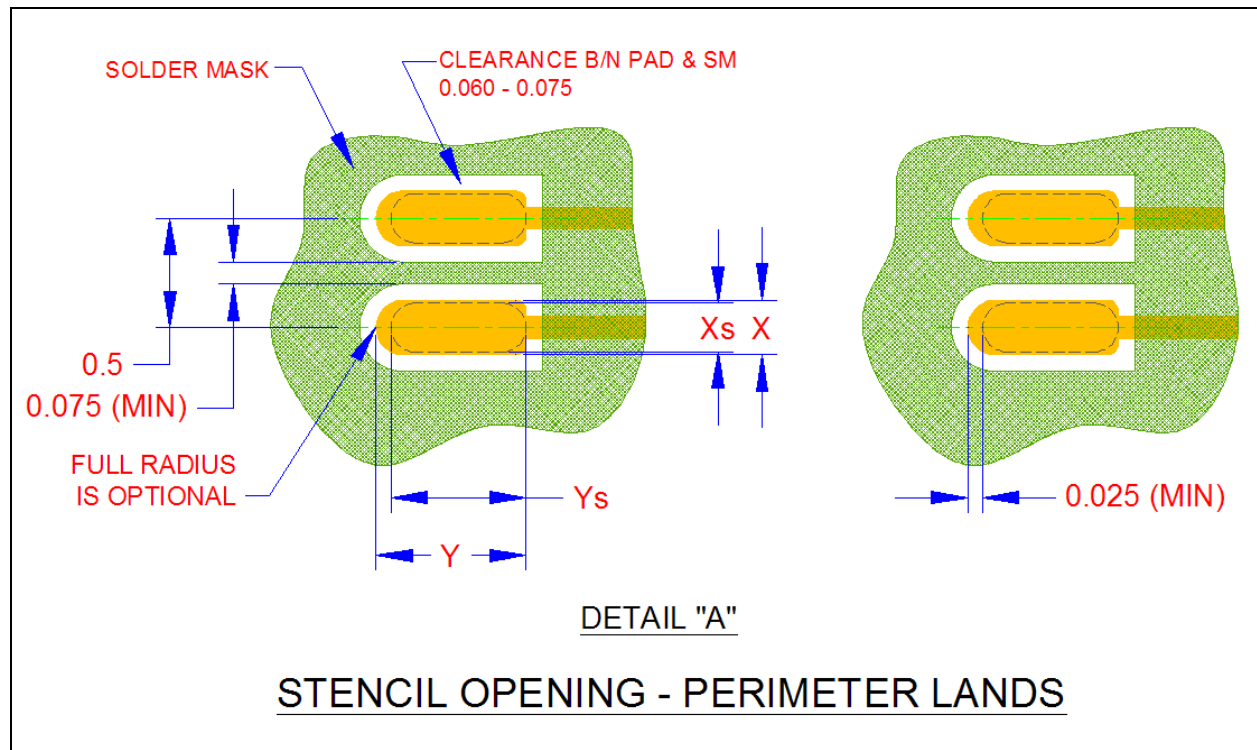

Figure 7.4 Package Detail A - Stencil Opening and Perimeter Lands

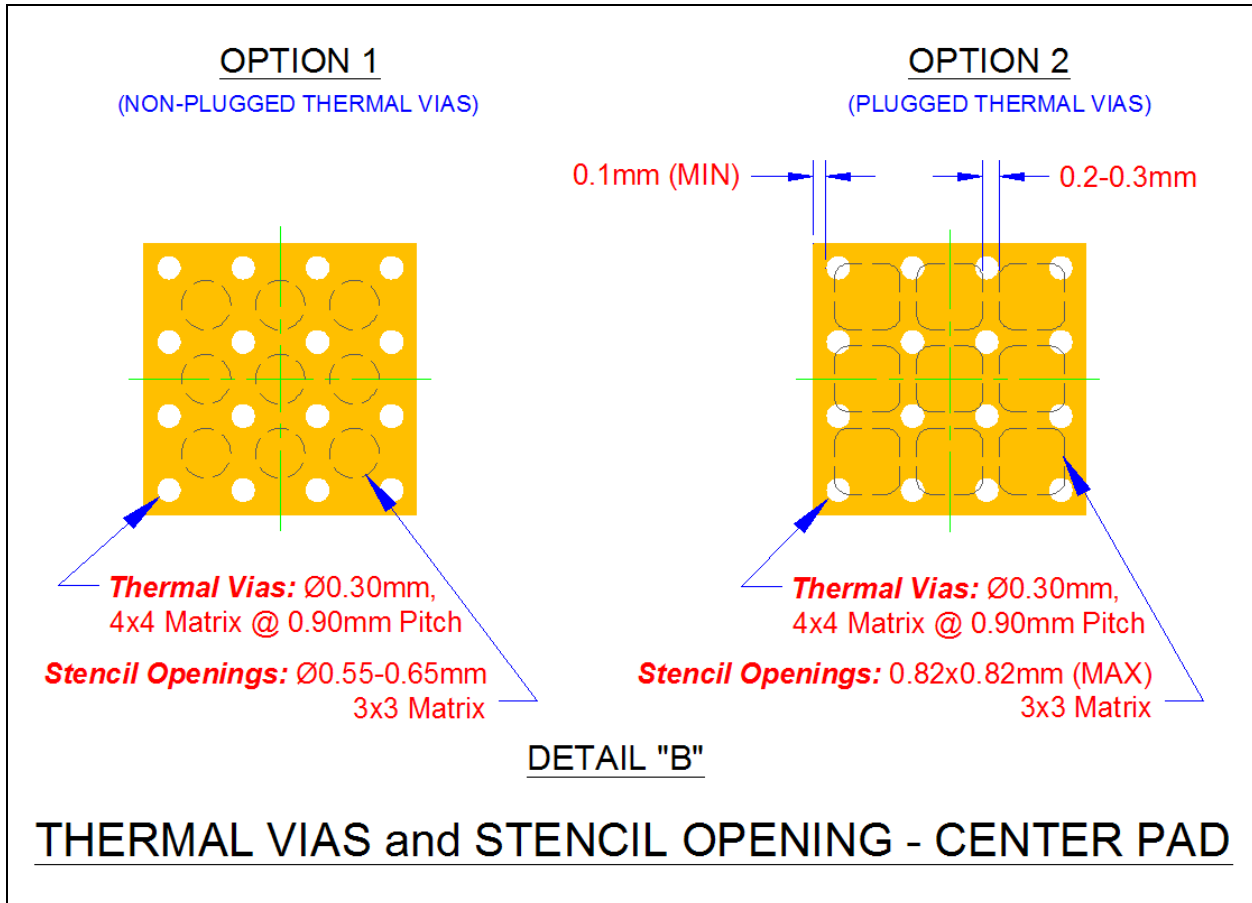

Figure 7.5 Package Detail B - Thermal Via and Stencil Opening

| LAND PATTERN DIMENSIONS |      |      |      |
|-------------------------|------|------|------|
| SYMBOL                  | MIN  | NOM  | MAX  |
| GD/GE                   | 4.00 | -    | 5.10 |
| GDs/GEs                 | 4.05 | -    | -    |
| D2'/E2'                 | -    | 3.30 | 3.30 |
| Pad: X                  | -    | 0.28 | 0.28 |
| Stencil: Xs             | -    | 0.23 | 0.25 |
| Pad: Y                  | -    | 0.69 | 0.69 |
| Stencil: Ys             | -    | 0.62 | 0.64 |
| e                       | 0.50 |      |      |

Figure 7.6 Package Land Pattern Dimensions

## 7.2 Package Marking

All packages will be marked as shown in [Figure 7.7](#).

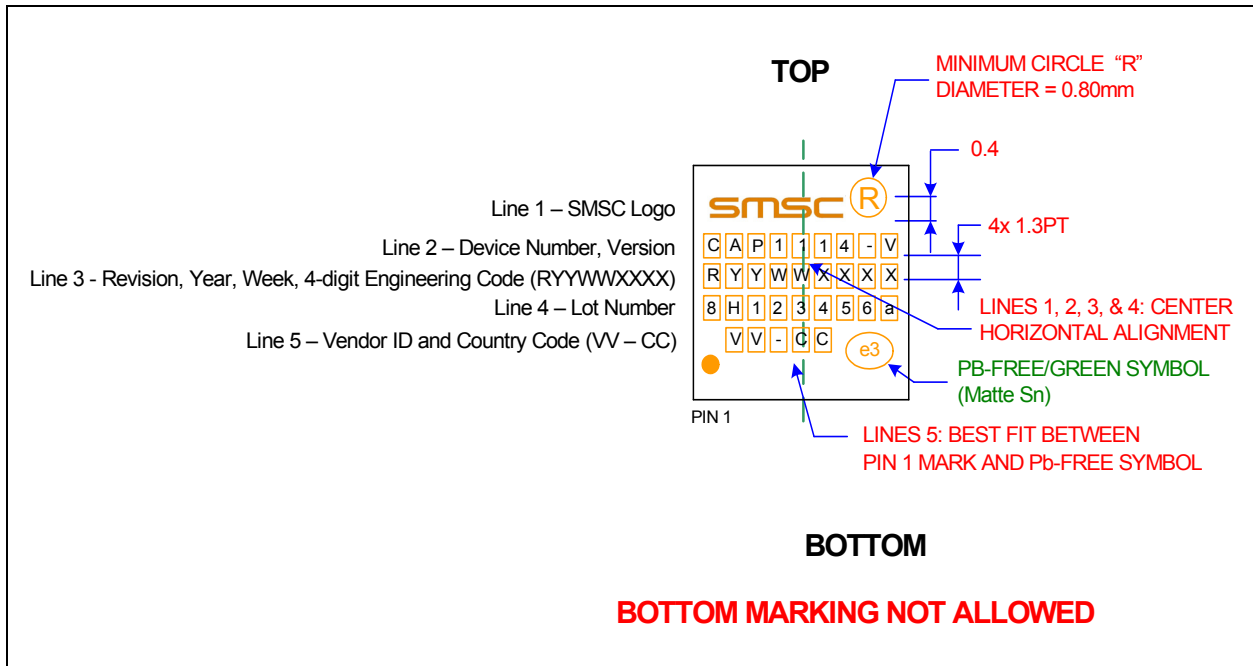

Figure 7.7 Package Markings

## Chapter 8 Datasheet Revision History

**Table 8.1 Customer Revision History**

| REVISION LEVEL & DATE | SECTION/FIGURE/ENTRY                                    | CORRECTION   |
|-----------------------|---|--|
| Rev. 1.1 (02-04-11)   | Cover   | RightTouch logo added.   |
|                       | Features  | Added: "Proximity detection" under "Capacitive Touch Inputs"   |
|                       | Section 6.35, "Proximity Control Register"              | Modified CS1_PROX and PROX_SUM descriptions  |
|                       | Chapter 1, Delta from CAP1014 to CAP1114                | Added delta chapter  |
|                       | Table 3.2, "Electrical Specifications"                  | Completed electrical specification values. Changed Time to Communications ( $t_{COMM}$ ) spec. from 15ms max to 15ms typ and 20ms max. Added drive frequency spec of 2kHz.   |
|                       | Figure 5.1, "System Diagram for CAP1114"                | Added resistors to LED lines.  |
|                       | Section 5.1, "Power States"                             | Description for DSLEEP recommended disabling LEDs. Except for LED11, LEDs are driven to non-actuated state with no PWM operations. Users can decide whether to disable or not.   |
|                       | Section 6.1, "Main Status Control Register"             | Description for DSLEEP set to 1 said LEDs (except LED11) are disabled. Instead, they are driven to their programmed non-actuated state and no PWM operations will be done.   |
|                       | Section 6.33, "Configuration 2 Register"                | Renamed INV_LINK_POL to INV_LINK_TRAN. It pertains to Linked LED Transition Controls.  |
|                       | Section 6.35, "Proximity Control Register"              | Added.   |
|                       | Section 6.43, "LED Output Control Registers"            | When LEDs are not linked to capacitive touch sensor channels, LED behaviors can still be used. A bit setting of 1 is activated.  |
|                       | Section 6.44, "LED Polarity Registers"                  | Split second application note into three notes to separate inverted versus non-inverted behavior and raise the importance of the assumption of how LEDs are connected. Added reference to system diagram. Clarified description of bit settings. LED <sub>x</sub> _POL = 0 is inverted system, and LED <sub>x</sub> _POL = 1 is non-inverted system. |
|                       | Table 6.64, "LED Polarity Behavior"                     | Updated table to reflect actual behavior.  |
|                       | Section 6.45, "Linked LED Transition Control Registers" | Updated. These controls work with the INV_LINK_TRAN bit (not polarity).  |
|                       | Section 6.46, "LED Mirror Control"                      | Updated to clarify.  |
|                       | Section 6.48, "LED Behavior Registers"                  | If an LED is not linked and breathing, it must be unactuated for behavior changes to take effect. Clarified explanation of how triggers start and stop.  |

## Datasheet

Table 8.1 Customer Revision History (continued)

| REVISION LEVEL & DATE | SECTION/FIGURE/ENTRY                                       | CORRECTION  |
|-----------------------|--|---|
|                       | Section 6.49, "LED Pulse 1 Period Register"                | Removed mirrored figures as behavior is the same. ST_TRIG applies to host drive, too.                   |
|                       | Section 6.50, "LED Pulse 2 Period Register"                | The pulse during which the release is detected counts as one of the pulses.                             |
|                       | Section 6.53, "LED Pulse and Breathe Duty Cycle Registers" | Duty cycle changes are only applied immediately in Direct behavior. Removed incorrect application note. |
|                       | Section 6.54, "LED Direct Ramp Rates Register"             | Ramp rates apply to host control, too.  |
|                       | Table 6.79, "Rise / Fall Rate Cycle Decode"                | For 750ms, bit settings are 011 instead of 111.   |
|                       | Section 6.55, "LED Off Delay Register"                     | Removed: "This register is only used if the LED is linked to a Capacitive Touch sensor."                |
| Rev. 1.0 (12-09-09)   | Formal release   |   |

Компания «Океан Электроники» предлагает заключение долгосрочных отношений при поставках импортных электронных компонентов на взаимовыгодных условиях!

Наши преимущества:

- Поставка оригинальных импортных электронных компонентов напрямую с производств Америки, Европы и Азии, а так же с крупнейших складов мира;
- Широкая линейка поставок активных и пассивных импортных электронных компонентов (более 30 млн. наименований);
- Поставка сложных, дефицитных, либо снятых с производства позиций;
- Оперативные сроки поставки под заказ (от 5 рабочих дней);
- Экспресс доставка в любую точку России;
- Помощь Конструкторского Отдела и консультации квалифицированных инженеров;
- Техническая поддержка проекта, помощь в подборе аналогов, поставка прототипов;
- Поставка электронных компонентов под контролем ВП;
- Система менеджмента качества сертифицирована по Международному стандарту ISO 9001;
- При необходимости вся продукция военного и аэрокосмического назначения проходит испытания и сертификацию в лаборатории (по согласованию с заказчиком);
- Поставка специализированных компонентов военного и аэрокосмического уровня качества (Xilinx, Altera, Analog Devices, Intersil, Interpoint, Microsemi, Actel, Aeroflex, Peregrine, VPT, Syfer, Eurofarad, Texas Instruments, MS Kennedy, Miteq, Cobham, E2V, MA-COM, Hittite, Mini-Circuits, General Dynamics и др.);

Компания «Океан Электроники» является официальным дистрибьютором и эксклюзивным представителем в России одного из крупнейших производителей разъемов военного и аэрокосмического назначения «JONHON», а так же официальным дистрибьютором и эксклюзивным представителем в России производителя высокотехнологичных и надежных решений для передачи СВЧ сигналов «FORSTAR».



## JONHON

«JONHON» (основан в 1970 г.)

Разъемы специального, военного и аэрокосмического назначения:

(Применяются в военной, авиационной, аэрокосмической, морской, железнодорожной, горно- и нефтедобывающей отраслях промышленности)

«FORSTAR» (основан в 1998 г.)

ВЧ соединители, коаксиальные кабели, кабельные сборки и микроволновые компоненты:

(Применяются в телекоммуникациях гражданского и специального назначения, в средствах связи, РЛС, а так же военной, авиационной и аэрокосмической отраслях промышленности).



Телефон: 8 (812) 309-75-97 (многоканальный)

Факс: 8 (812) 320-03-32

Электронная почта: [ocean@oceanchips.ru](mailto:ocean@oceanchips.ru)

Web: <http://oceanchips.ru/>

Адрес: 198099, г. Санкт-Петербург, ул. Калинина, д. 2, корп. 4, лит. А