

CAN BUS TRANSCEIVER

- L9615 MEETS ISO/DIS 11898 UP TO 500KBAUD
- TRANSMITTER
 - GENERATION OF DIFFERENTIAL OUTPUT SIGNALS
 - SHORT CIRCUIT PROTECTED FROM -5V TO 36V, DETECTION & SHUTDOWN
 - SLOPE CONTROL TO REDUCE RFI AND EMI
 - TWO STATES ADJUSTABLE SLOPE CONTROL ($\leq 500\text{KBAUD}/\leq 125\text{KBAUD}$)
- RECEIVER
 - DIFFERENTIAL INPUT WITH HIGH INTERFERENCE SUPPRESSION
 - COMMON MODE INPUT VOLTAGE RANGE (V_{COM}) FROM -2V TO $V_{\text{S}}+3\text{V}$
- PACKAGE: SO 8

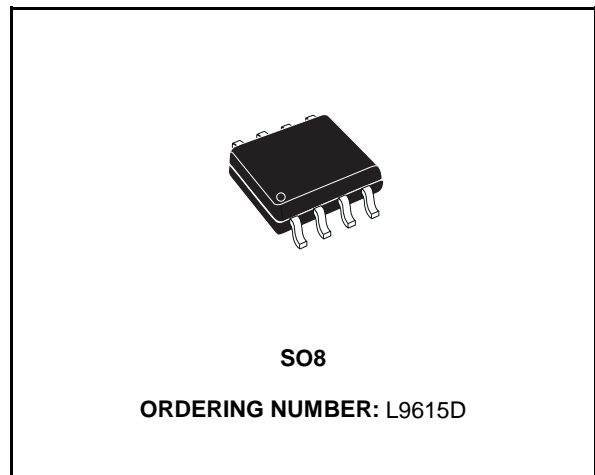

DESCRIPTION

The L9615 is a bidirectional transceiver for signal

conditioning and processing in connection with a CAN controller. Data rates of up to 500KBAUD are supported using either shielded or non-shielded pair of lines.

BLOCK DIAGRAM

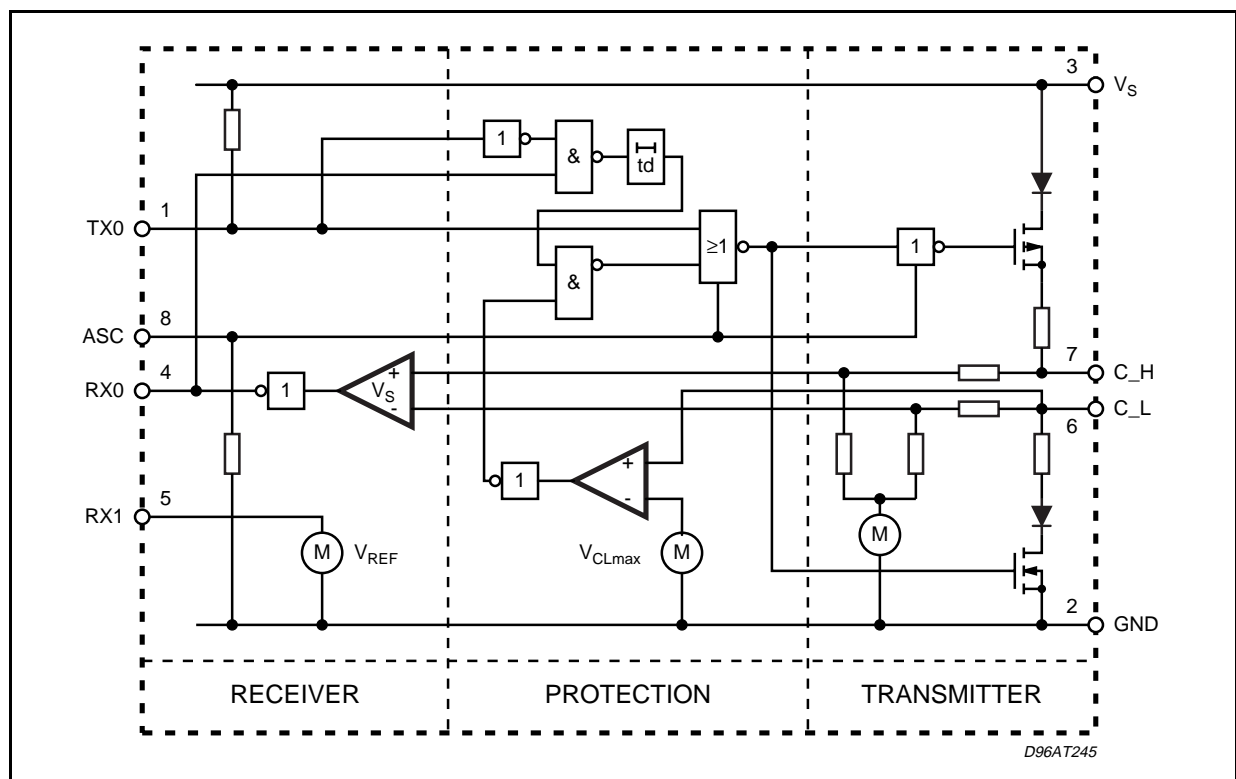

ABSOLUTE MAXIMUM RATINGS

Symbol	Parameter	Value	Unit
V_S	Supply Voltage	-0.3 to 7	V
V_{C_H}, V_{C_L}	Bus Voltage at C_H, C_L (VS 0 to 5.5V)	-5 to 36	V
I_{C_H}, I_{C_L}	Off State Leakage Current at C_H, C_L (VS =0 to 5.5V, $V_{C_H} = -5$ to 36V, $V_{C_L} = -5$ to 36)	-3 to 5	mA
V_{DC}	DC Voltage at TXO, ASC (VS 0 to 5.5V)	GND -0.3 to $V_S + 0.3$	V
I_{RXO}	Output Current at RXO (VS 0 to 5.5V)	-0.3 to 1	mA
T_{stg}, T_J	Storage and Junction Temperature Range	-40 to 150	°C
T_{op}	Operating Temperature Range	-40 to 110	°C

All voltages, except bus voltage, are defined with respect to pin 2
 Positive currents flow into the IC.

PIN CONNECTION

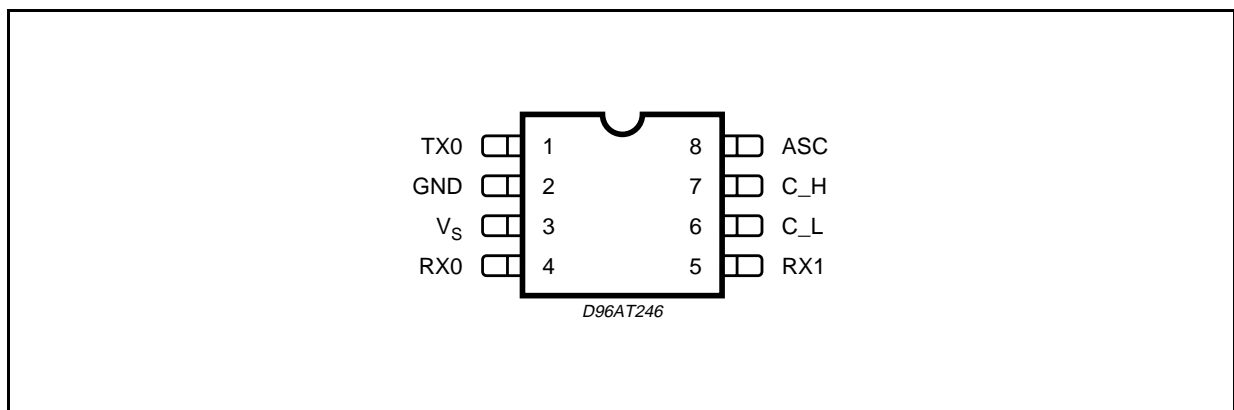

THERMAL DATA

Symbol	Parameter	Value	Unit

PIN FUNCTIONS

N.	Name	Function
1	TXO	Transmitter Input
2	GND	Ground
3	V_S	Supply Voltage
4	RXO	Receive Output
5	RX1	Reference Voltage
6	C_L	Low Side Bus Output
7	C_H	High Side Bus Output
8	ASC	Adjustable Slope Control

ELECTRICAL CHARACTERISTICS ($T_{OP} = -40$ to 110°C ; $V_S = 4.5$ to 5.5V ; Dominant: $V_{TXO} = \text{GND}$; Recessive: $V_{TXO} = V_S$; All voltages, except bus voltage, are defined with respect to pin 2. Positive currents flow into the IC unless otherwise specified.)

Symbol	Parameter	Test Condition	Min.	Typ.	Max.	Unit
V_S	Supply Voltage		4.5	5	5.5	V
I_S	Supply Current	Dominant			80	mA
		Recessive			20	mA
TRANSMITTER SECTION ($R_A = 60\Omega$ between C_H and C_L)						
C_{TXO}	TXO Input Capacitance	$0\text{V} < V_{TXO} < V_S$		25		pF
V_{TXO}	TXO High Level Input Voltage		$0.7 V_S$		V_S	
	TXO Low Level Input Voltage		0		$0.3 V_S$	
I_{TXO}	TXO High Level Input Current	$V_{TXO} = V_S$	-2	0	2	μA
	TXO Low Level Input Current	$V_{TXO} = \text{GND}$	-275	0	-25	μA
C_{ASC}	ASC Input Capacitance	$0\text{V} < V_{ASC} < V_S$		25		pF
V_{ASC}	ASC Input Voltage for High Speed		0		$0.1 V_S$	
	ASC Input Voltage for Low Speed		$0.9 V_S$		V_S	
I_{ASC}	ASC Input Current	$V_{ASC} = V_S$	25		275	μA
		$V_{ASC} = 0\text{V}$	-2	0	2	μA
V_{C_H}, V_{C_L}	Bus Voltage Recessive	Recessive	$0.4 V_S$	$0.5 V_S$	$0.6 V_S$	
I_{C_H}, I_{C_L}	Leakage Current Recessive	$V_{C_L} = V_{C_H} = -2$ to 7V	-0.7		0.7	mA
		$V_{C_L} = V_{C_H} = 1$ to 4V	-0.3		0.3	mA
$R_{IN}(C_H, C_L)$	Input Resistance	Recessive	5		50	$\text{K}\Omega$
$R_{Diff}(C_H, C_L)$	Differential Input Resistance	Recessive	10		100	$\text{K}\Omega$
$V_{Diff} = V_{C_H} - V_{C_L}$	Differential Output Voltage	Dominant, R_A	1.5		3	V
$V_{Diff} = V_{C_H} - V_{C_L}$	Differential Output Voltage	Recessive	-500	0	50	mV
t_d	Short Circuit Detection Time C_H to C_L ; C_H to B	$R_{CS} < 1\Omega$	1	5	10	μs
I_A	Supply Current in Case of Short Circuit, C_H to C_L , C_H to B (time = t_d)			150		mA
V_{C_Lmax}	Overvoltage Protection Threshold on C_L		7	8	10	V
RECEIVE SECTION						
V_{RXO}	RXO High Level Output Voltage	$V_{Diff} < 0.5\text{V}$; $I_{RXO} = 0.3\text{mA}$; $V_{C_H} = -2$ to 7V ; $V_{C_L} = -2$ to 7V ;	$0.9 V_S$		V_S	V
	RXO Low Level Output Voltage	$V_{Diff} > 0.9\text{V}$; $I_{RXO} = 1\text{mA}$; $V_{C_H} = -2$ to 7V ; $V_{C_L} = -2$ to 7V ;			0.5	V
$V_S = V_{C_H} - V_{C_L}$	Input Signal Threshold	$V_{C_H} = -2$ to 7V ; $V_{C_L} = -2$ to 7V ;	500	700	900	mV
$V_{COM} = (V_{C_H} + V_{C_L})/2$	Input Common Mode Voltage Range		-2		7	V
V_{HYS}	Differential Input Hysteresis			150		mV
REFERENCE OUTPUT						
V_{RX1}	Reference Voltage	$I_{RX1} = 0$	$0.45 V_S$	$0.5 V_S$	$0.55 V_S$	V
R_{RX1}	Output Resistance		2		9	$\text{K}\Omega$

L9615

DINAMIC CHARACTERISTICS ($C_A = 47\text{pF}$ between C_H and C_L ; $V_S = 5\text{V}$; $t_R < 5\text{ns}$; $C_{RXO} = 20\text{pF}$ between RXO and B ; $R_A = 60\Omega$ between C_H and C_L)

Symbol	Parameter	Test Condition	Min.	Typ.	Max.	Unit
t_{OT}	Signal Delay TXO to C_H , C_L				50	ns
SR	Differential Output Slew Rate (Transmitter)	$V_{ASC} = 0\text{V}$	20		50	$\text{V}/\mu\text{s}$
		$V_{ASC} = V_S$	5		20	$\text{V}/\mu\text{s}$
t_{OR}	Signal Delay C_H , C_L to RXO	$V_{ASC} = 0\text{V}$			150	ns
t_{OTR}	Signal Delay Txo to Rxo	$V_{ASC} = 0\text{V}$			300	ns

FUNCTIONAL DESCRIPTION

The L9615 is used as an interface between a CAN controller and the physical bus. The device provides transmitting capability to the CAN controller.

The transmitter outputs C_H and C_L are protected against short circuits and electrical transients which may occur in an automotive environment. In case of short circuit (C_H to C_L , C_H to B) the protection circuit recognizes this fault condition and the transmitter output stages are disabled with a delay of max. $10\mu\text{s}$ to prevent destruction of the IC and high consumption of supply current I_S . If $V_{C_L} > V_{C_Lmax}$ the transmitter output stages would be disabled immediately.

Pin ASC makes it possible to select two different

modes of operation: High speed ($\leq 500\text{kBaud}$) and low speed ($\leq 125\text{kBaud}$).

The ASC pin is tied to GND for normal operation at $\leq 500\text{kBaud}$. For slower speed operation at $\leq 125\text{kBaud}$ the rise and fall slope of the bus output can be decreased to reduce EMI by connecting the ASC pin to V_S .

FUNCTIONAL TABLE

TXO	C_H	C_L	Bus State	RXO
L	H	L	Dominant	L
H or Floating	Floating $V_S/2$	Floating $V_S/2$	Recessive	H

TYPICAL APPLICATION

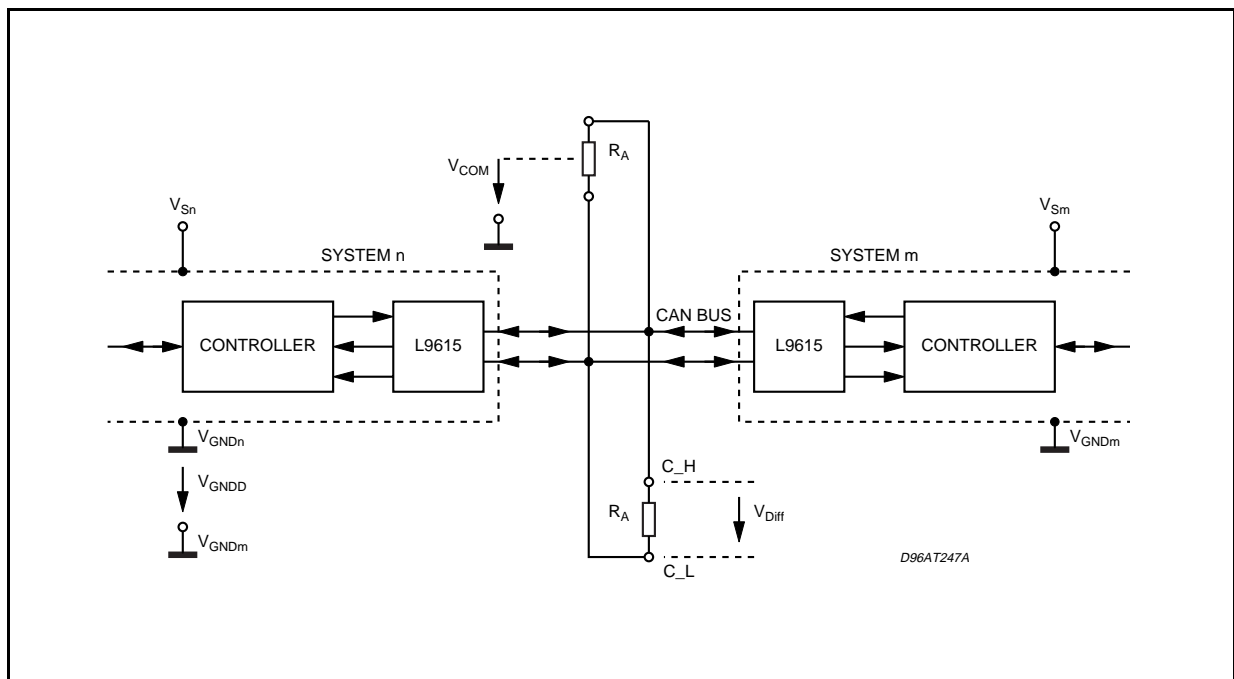

TIMING DIAGRAM



EMC PERFORMANCE (RECEIVER)



EMC PERFORMANCE (TRANSMITTER)



Transceiver Without Emc Reducing Measures

Transceiver With Emc Reducing Measures

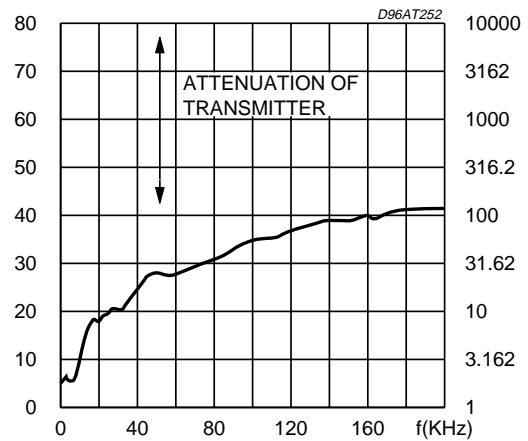
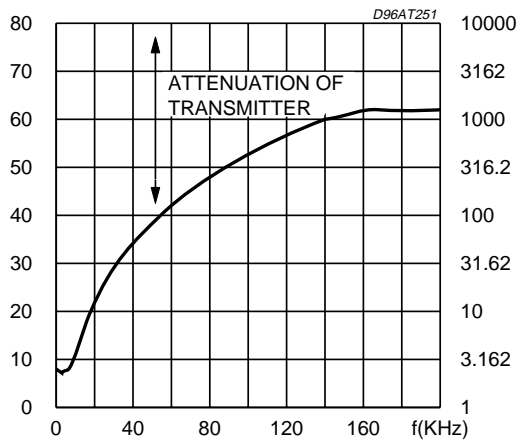

EMC PERFORMANCE (Transceiver Sending)

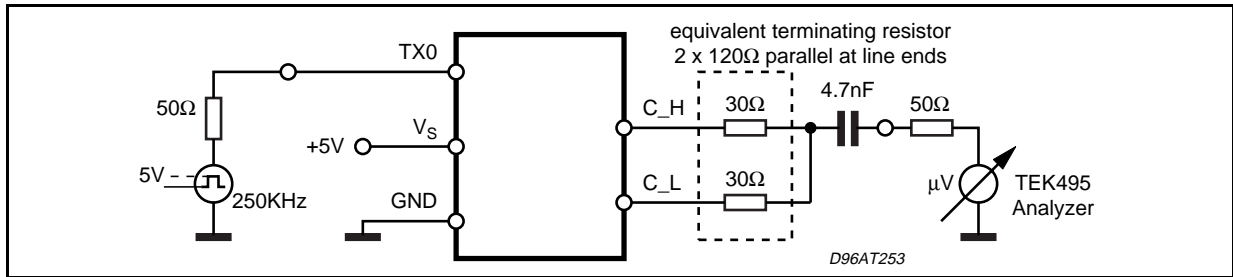

Transceiver Without Emc Reducing Measures

Transceiver With Emc Reducing Measures

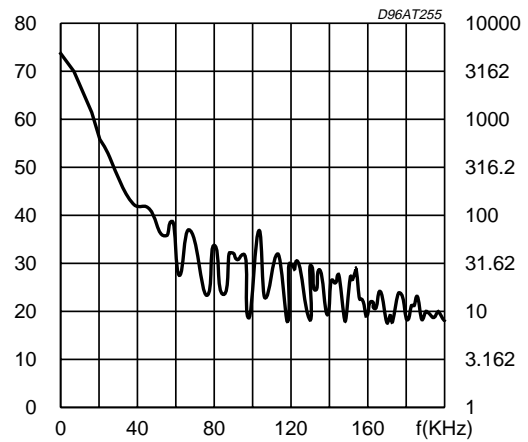
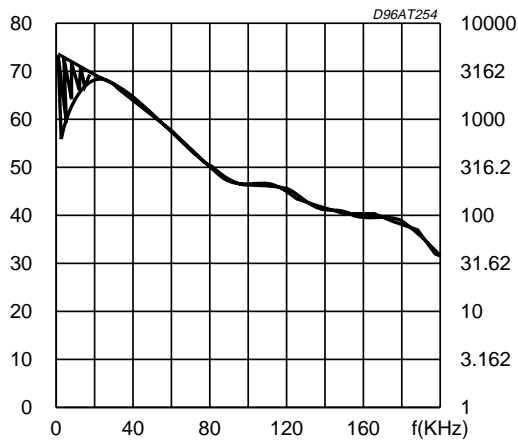

DIM.	mm			inch		
	MIN.	TYP.	MAX.	MIN.	TYP.	MAX.
A			1.75			0.069
a1	0.1		0.25	0.004		0.010
a2			1.65			0.065
a3	0.65		0.85	0.026		0.033
b	0.35		0.48	0.014		0.019
b1	0.19		0.25	0.007		0.010
C	0.25		0.5	0.010		0.020
c1	45° (typ.)					
D (1)	4.8		5.0	0.189		0.197
E	5.8		6.2	0.228		0.244
e		1.27			0.050	
e3		3.81			0.150	
F (1)	3.8		4.0	0.15		0.157
L	0.4		1.27	0.016		0.050
M			0.6			0.024
S	8° (max.)					

OUTLINE AND MECHANICAL DATA

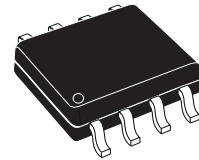

SO8

(1) D and F do not include mold flash or protrusions. Mold flash or protrusions shall not exceed 0.15mm (.006inch).

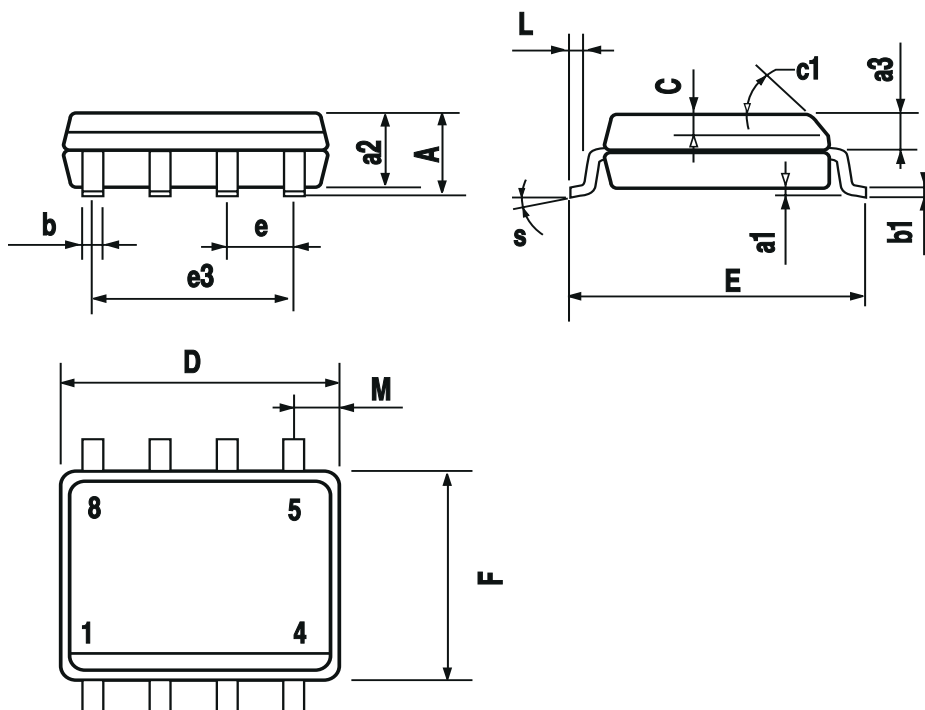

Please Read Carefully:

Information in this document is provided solely in connection with ST products. STMicroelectronics NV and its subsidiaries ("ST") reserve the right to make changes, corrections, modifications or improvements, to this document, and the products and services described herein at any time, without notice.

All ST products are sold pursuant to ST's terms and conditions of sale.

Purchasers are solely responsible for the choice, selection and use of the ST products and services described herein, and ST assumes no liability whatsoever relating to the choice, selection or use of the ST products and services described herein.

No license, express or implied, by estoppel or otherwise, to any intellectual property rights is granted under this document. If any part of this document refers to any third party products or services it shall not be deemed a license grant by ST for the use of such third party products or services, or any intellectual property contained therein or considered as a warranty covering the use in any manner whatsoever of such third party products or services or any intellectual property contained therein.

UNLESS OTHERWISE SET FORTH IN ST'S TERMS AND CONDITIONS OF SALE ST DISCLAIMS ANY EXPRESS OR IMPLIED WARRANTY WITH RESPECT TO THE USE AND/OR SALE OF ST PRODUCTS INCLUDING WITHOUT LIMITATION IMPLIED WARRANTIES OF MERCHANTABILITY, FITNESS FOR A PARTICULAR PURPOSE (AND THEIR EQUIVALENTS UNDER THE LAWS OF ANY JURISDICTION), OR INFRINGEMENT OF ANY PATENT, COPYRIGHT OR OTHER INTELLECTUAL PROPERTY RIGHT.

ST PRODUCTS ARE NOT DESIGNED OR AUTHORIZED FOR USE IN: (A) SAFETY CRITICAL APPLICATIONS SUCH AS LIFE SUPPORTING, ACTIVE IMPLANTED DEVICES OR SYSTEMS WITH PRODUCT FUNCTIONAL SAFETY REQUIREMENTS; (B) AERONAUTIC APPLICATIONS; (C) AUTOMOTIVE APPLICATIONS OR ENVIRONMENTS, AND/OR (D) AEROSPACE APPLICATIONS OR ENVIRONMENTS. WHERE ST PRODUCTS ARE NOT DESIGNED FOR SUCH USE, THE PURCHASER SHALL USE PRODUCTS AT PURCHASER'S SOLE RISK, EVEN IF ST HAS BEEN INFORMED IN WRITING OF SUCH USAGE, UNLESS A PRODUCT IS EXPRESSLY DESIGNATED BY ST AS BEING INTENDED FOR "AUTOMOTIVE, AUTOMOTIVE SAFETY OR MEDICAL" INDUSTRY DOMAINS ACCORDING TO ST PRODUCT DESIGN SPECIFICATIONS. PRODUCTS FORMALLY ESCC, QML OR JAN QUALIFIED ARE DEEMED SUITABLE FOR USE IN AEROSPACE BY THE CORRESPONDING GOVERNMENTAL AGENCY.

Resale of ST products with provisions different from the statements and/or technical features set forth in this document shall immediately void any warranty granted by ST for the ST product or service described herein and shall not create or extend in any manner whatsoever, any liability of ST.

ST and the ST logo are trademarks or registered trademarks of ST in various countries.

Information in this document supersedes and replaces all information previously supplied.

The ST logo is a registered trademark of STMicroelectronics. All other names are the property of their respective owners.

© 2013 STMicroelectronics - All rights reserved

STMicroelectronics group of companies

Australia - Belgium - Brazil - Canada - China - Czech Republic - Finland - France - Germany - Hong Kong - India - Israel - Italy - Japan - Malaysia - Malta - Morocco - Philippines - Singapore - Spain - Sweden - Switzerland - United Kingdom - United States of America

www.st.com

Компания «Океан Электроники» предлагает заключение долгосрочных отношений при поставках импортных электронных компонентов на взаимовыгодных условиях!

Наши преимущества:

- Поставка оригинальных импортных электронных компонентов напрямую с производств Америки, Европы и Азии, а так же с крупнейших складов мира;
- Широкая линейка поставок активных и пассивных импортных электронных компонентов (более 30 млн. наименований);
- Поставка сложных, дефицитных, либо снятых с производства позиций;
- Оперативные сроки поставки под заказ (от 5 рабочих дней);
- Экспресс доставка в любую точку России;
- Помощь Конструкторского Отдела и консультации квалифицированных инженеров;
- Техническая поддержка проекта, помощь в подборе аналогов, поставка прототипов;
- Поставка электронных компонентов под контролем ВП;
- Система менеджмента качества сертифицирована по Международному стандарту ISO 9001;
- При необходимости вся продукция военного и аэрокосмического назначения проходит испытания и сертификацию в лаборатории (по согласованию с заказчиком);
- Поставка специализированных компонентов военного и аэрокосмического уровня качества (Xilinx, Altera, Analog Devices, Intersil, Interpoint, Microsemi, Actel, Aeroflex, Peregrine, VPT, Syfer, Eurofarad, Texas Instruments, MS Kennedy, Miteq, Cobham, E2V, MA-COM, Hittite, Mini-Circuits, General Dynamics и др.);

Компания «Океан Электроники» является официальным дистрибьютором и эксклюзивным представителем в России одного из крупнейших производителей разъемов военного и аэрокосмического назначения «JONHON», а так же официальным дистрибьютором и эксклюзивным представителем в России производителя высокотехнологичных и надежных решений для передачи СВЧ сигналов «FORSTAR».



JONHON

«JONHON» (основан в 1970 г.)

Разъемы специального, военного и аэрокосмического назначения:

(Применяются в военной, авиационной, аэрокосмической, морской, железнодорожной, горно- и нефтедобывающей отраслях промышленности)

«FORSTAR» (основан в 1998 г.)

ВЧ соединители, коаксиальные кабели, кабельные сборки и микроволновые компоненты:

(Применяются в телекоммуникациях гражданского и специального назначения, в средствах связи, РЛС, а так же военной, авиационной и аэрокосмической отраслях промышленности).



Телефон: 8 (812) 309-75-97 (многоканальный)

Факс: 8 (812) 320-03-32

Электронная почта: ocean@oceanchips.ru

Web: <http://oceanchips.ru/>

Адрес: 198099, г. Санкт-Петербург, ул. Калинина, д. 2, корп. 4, лит. А