

MIC4801



High Efficiency 600mA Single Channel Linear WLED Driver with Ultra Fast PWM™ Control

General Description

The MIC4801 is a high efficiency White LED (WLED) driver designed to drive a single LED up to 600mA. The MIC4801 constant current driver is designed to drive high power LED's in various lighting applications. The MIC4801 provides the highest possible efficiency as this architecture has no switching losses present in traditional charge pumps or inductive boost circuits. It features a typical dropout of 130mV at 400mA. This allows the LEDs to be driven directly from the voltage source eliminating switching noise/losses present with the use of boost circuitry. The high accuracy ($\pm 1\%$ typical) current regulated WLED channel ensures uniform display illumination under all conditions. The brightness is controlled through an Ultra Fast PWM™ Control interface operating down to less than 1% duty cycle.

The MIC4801 is available in an 8-pin SOIC package with a junction temperature range of -40°C to $+125^{\circ}\text{C}$.

Datasheets and support documentation can be found on Micrel's web site at: www.micrel.com.

Features

- High Efficiency (no Voltage Boost losses)
- Ultra Fast PWM™ control (200Hz to 500kHz)
- Input voltage range: 3.0V to 5.5V
- Dropout of 130mV at 400mA
- Programmable LED current with external resistor
- Current accuracy of $\pm 1\%$ typical

Applications

- Bill board displays
- Marquee displays
- Instrument displays
- Architectural lighting

Typical Application

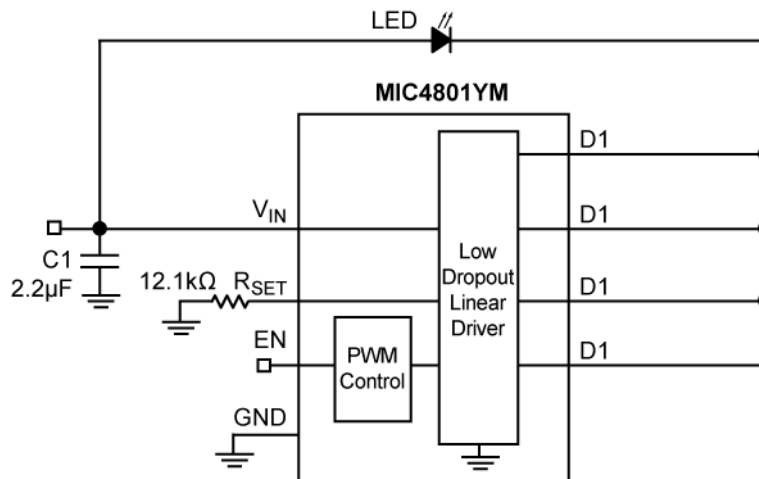

High Current Lighting Schematic

Ultra Fast PWM is a trademark of Micrel, Inc.

Micrel Inc. • 2180 Fortune Drive • San Jose, CA 95131 • USA • tel +1 (408) 944-0800 • fax + 1 (408) 474-1000 • <http://www.micrel.com>

Ordering Information

Part Number	Temperature Range	Package
MIC4801YM	-40°C to +125°C	8-Pin SOIC

Pin Configuration

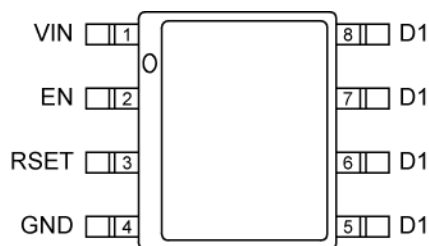

8-Pin SOIC (M)
(Top View)

Pin Description

Pin Number	Pin Name	Pin Function
1	VIN	Voltage Input. Connect at least 2.2 μ F ceramic capacitor between VIN and GND.
2	EN	Enable LED drivers. This pin can be used as a PWM input for dimming of WLEDs. Do not leave floating.
3	RSET	An internal 1.27V reference sets the nominal maximum WLED current. Example, apply a 12.1k Ω resistor between RSET and GND to set LED current to 416mA at 100% duty cycle.
4	GND	Ground.
5	D1	LED1 driver input. Connect LED anode to VIN and cathode to this pin. All D1 pins must be connected to the LED.
6	D1	LED1 driver input. Connect LED anode to VIN and cathode to this pin. All D1 pins must be connected to the LED.
7	D1	LED1 driver input. Connect LED anode to VIN and cathode to this pin. All D1 pins must be connected to the LED.
8	D1	LED1 driver input. Connect LED anode to VIN and cathode to this pin. All D1 pins must be connected to the LED.

Absolute Maximum Ratings⁽¹⁾

Main Input Voltage (V_{IN})	-0.3V to +6V
Enable Input Voltage (V_{EN})	-0.3V to +6V
LED Driver Voltage (V_{D1})	-0.3V to +6V
Power Dissipation	Internally Limited
Lead Temperature (soldering, 10sec.)	260°C
Storage Temperature (T_s)	-65°C to +150°C

Operating Ratings⁽²⁾

Supply Voltage (V_{IN})	+3.0V to +5.5V
Enable Input Voltage (V_{EN})	0V to V_{IN}
LED Driver Voltage (V_{D1})	0V to V_{IN}
Junction Temperature (T_J)	-40°C to +125°C
Junction Thermal Resistance	
SOIC-8L (θ_{JA})	98.9°C/W

Electrical Characteristics

$V_{IN} = V_{EN} = 5V$, $R_{SET} = 12.1k\Omega$; $V_{D1} = 1.2V$; $T_J = 25^\circ C$, **bold** values indicate $-40^\circ C \leq T_J \leq 125^\circ C$; unless noted.

Parameter	Conditions	Min	Typ	Max	Units
Current Accuracy ⁽³⁾		374	416	458	mA
Drop-out	Where $I_{LED} = 90\%$ of LED current seen at $V_{DROP\,NOM} = 1.2V$, 100% brightness level		130	250	mV
Ground/Supply Bias Current	$I_{OUT} = 416mA$		2.2	2.9	mA
Shutdown Current	$V_{EN} = 0V$		0.01	1	μA
PWM Dimming					
Enable Input Voltage (V_{EN})	Logic Low			0.2	V
	Logic High	1.2			V
Enable Input Current	$V_{IH} \geq 1.2V$		0.01	1	μA
Current Source Delay (50% levels)	Shutdown to on		40	60	μs
	Standby to on		2		μs
	On to Standby		0.3		μs
Current Source Transient Time (10%-90%)	T_{RISE}		1		μs
	T_{FALL}		0.3		μs
Stand-by to Shutdown Time	$V_{EN} = 0V$	10	20	40	ms

Notes:

1. Exceeding the absolute maximum rating may damage the device.
2. The device is not guaranteed to function outside its operating rating.
3. As determined by average current based on R_{SET} resistance.

Typical Characteristics

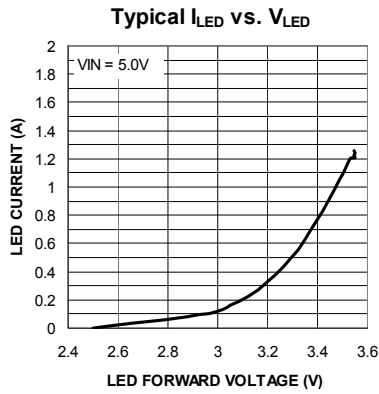
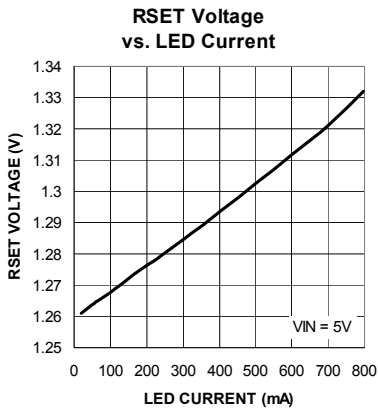
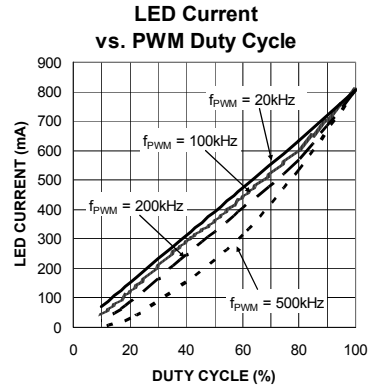
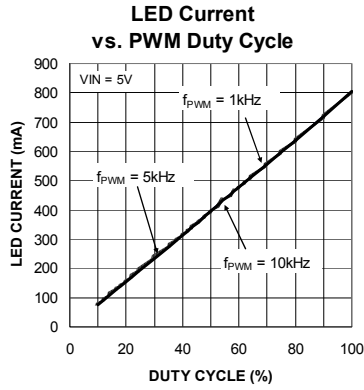
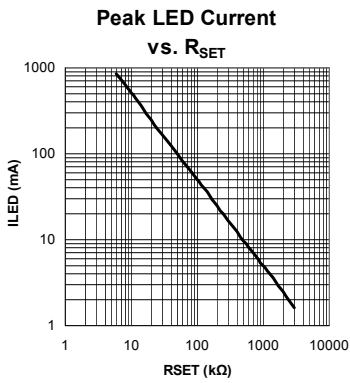
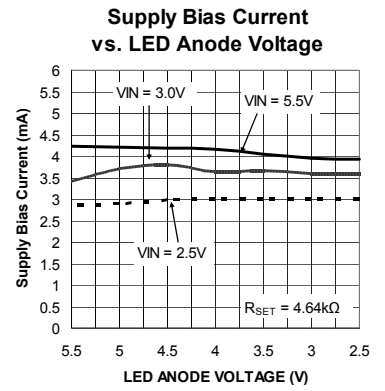
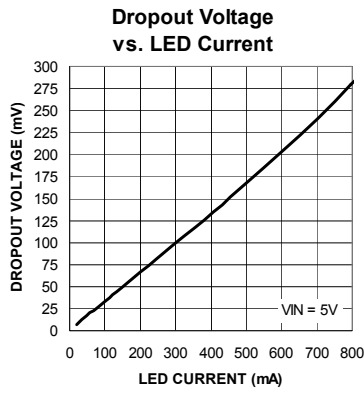
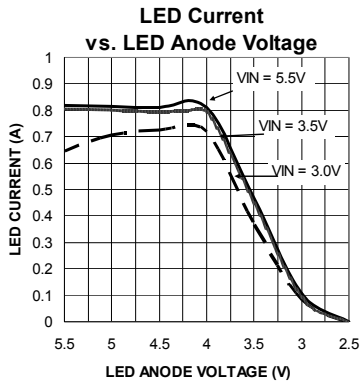

Functional Characteristics

LED Startup into 10% Duty Cycle

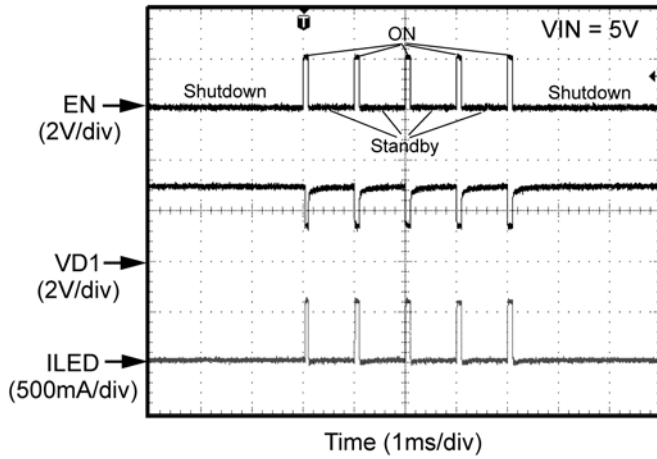

Shutdown to ON

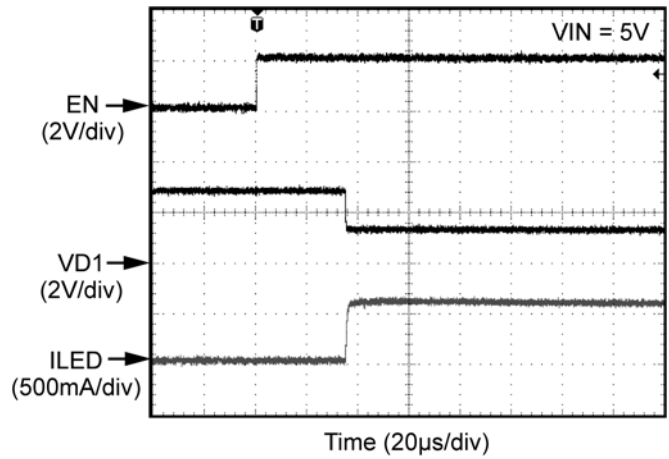

Standby to ON

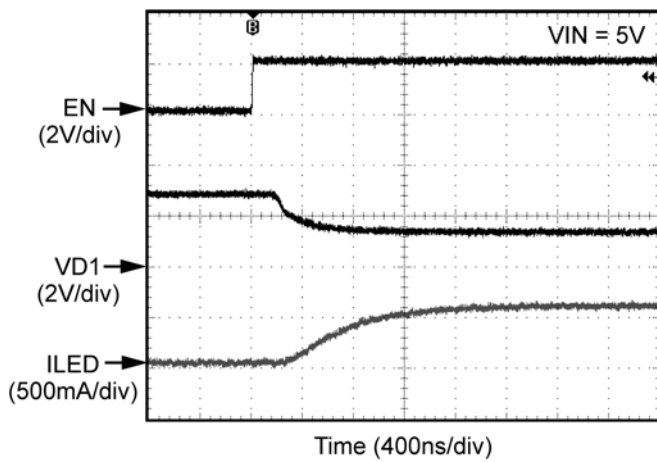

ON to Standby

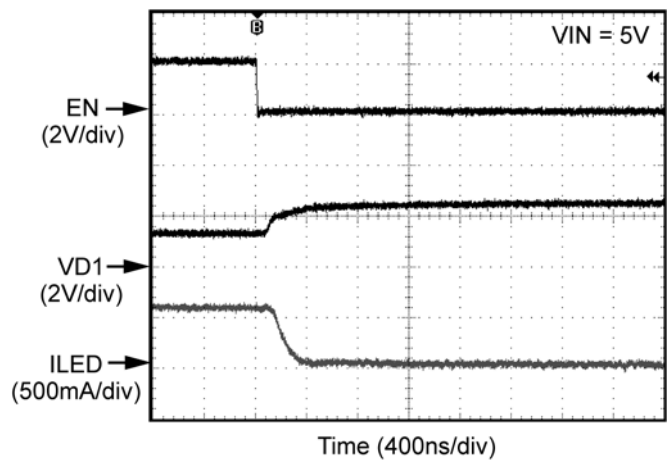

ON to Shutdown

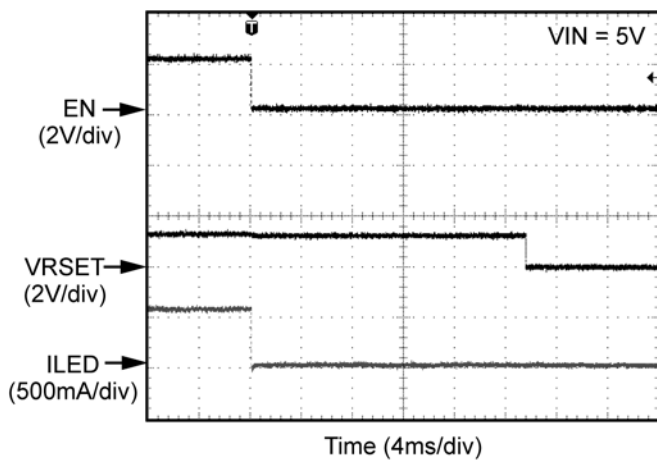

Functional Diagram

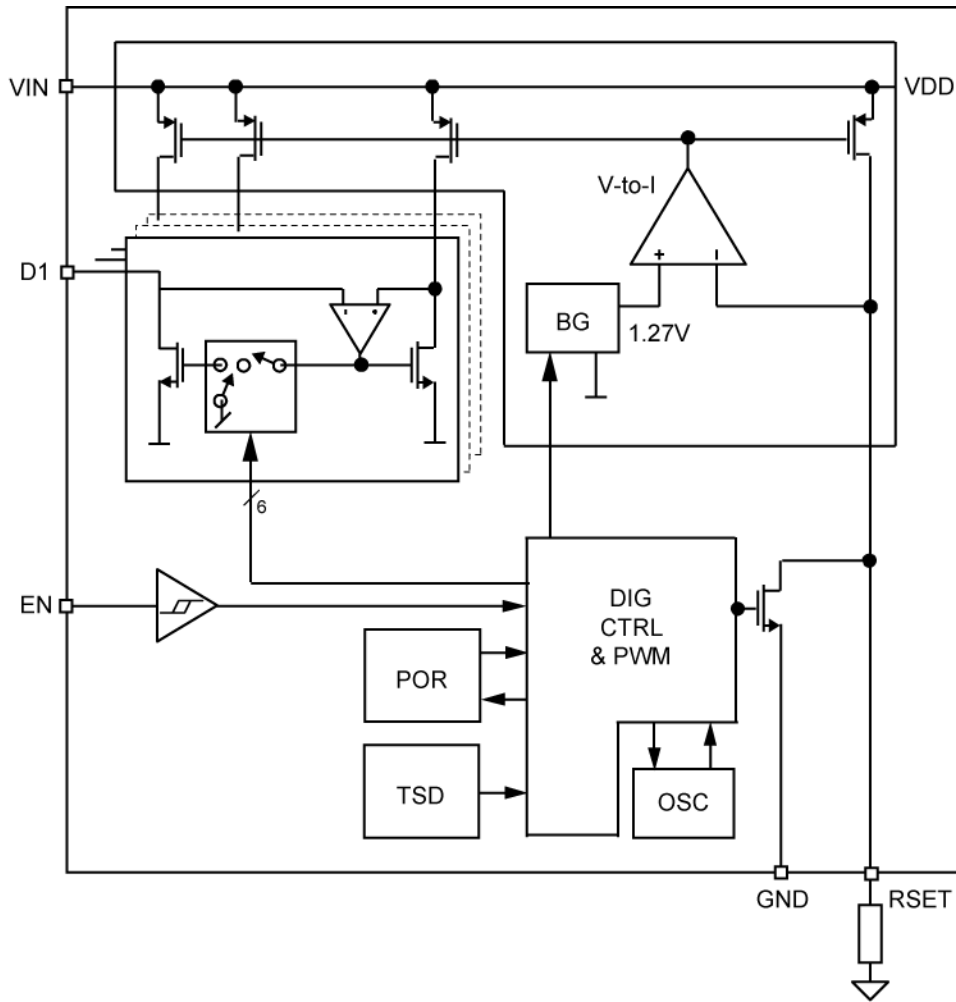

Figure 1. MIC4801 Functional Block Diagram

Functional Description

The MIC4801 is a single channel linear LED driver with a maximum 600mA current capability. The LED driver is designed to maintain proper current regulation with LED current accuracy of $\pm 10\%$. The dropout is 130mV at 400mA. The low dropout of the linear drivers allows the LEDs to be driven directly from the battery voltage and eliminates the need for boost or large and inefficient charge pumps. The maximum LED current for each channel is set via an external resistor. Dimming is controlled by applying a PWM signal to the EN pin. The MIC4801 accommodates a wide PWM frequency range as outlined in the application information section.

Block Diagram

As shown in Figure 1, the MIC4801 consists of current mirrors set to copy a master current determined by R_{SET} . The linear LED drivers have a designated control block for enabling and dimming of the LEDs. The MIC4801 dimming is controlled by the Ultra Fast PWM™ control block that receives PWM signals for dimming.

VIN

The input supply (V_{IN}) provides power to the linear LED drivers and the control circuitry. The V_{IN} operating range is 3V to 5.5V. A minimum bypass capacitor of 2.2 μ F should be placed close to the input (VIN) pin and the ground (GND) pin. Refer to the layout recommendations section for details on placing the input capacitor (C1).

EN

The EN pin is equivalent to the enable pin for the linear drivers on the MIC4801. It can also be used for dimming by applying a PWM signal. See the PWM Dimming Interface in the Application Information section for details. Pulling the EN low for more than 40ms puts the MIC4801 into a low I_Q sleep mode. The EN pin cannot be left floating; a floating enable pin may cause an indeterminate state on the outputs. The first pulse on the EN pin must be equal or greater than 60 μ s to wake the part up in a known state. This equates to a 8.3kHz PWM signal at equal or greater than 50% duty cycle. Higher PWM frequencies may be used but the first pulse must be equal or greater than 60 μ s.

RSET

The R_{SET} pin is used to set the peak current of the linear driver by connecting a R_{SET} resistor to ground. The theoretical average LED current can be estimated by equation (1):

$$I_{LED} \text{ (mA)} = 4920 * D / R_{SET} \text{ (k}\Omega) \tag{1}$$

$$R_{SET} \text{ (k}\Omega) = 4920 * D / I_{LED} \text{ (mA)} \tag{2}$$

D is the duty cycle of the LED current during PWM dimming. When the device is fully ON the duty cycle equals 100% (D = 1). A plot of I_{LED} versus R_{SET} is shown in Figure 2.

Due to DC losses across current paths internal and external to the package, the calculated R_{SET} resistance equation is modified by a factor K, where K is calculated to be 0.140k Ω .

$$R_{SET} \text{ (k}\Omega) = 4920 * D / I_{LED} \text{ (mA)} + 0.140 \text{ (k}\Omega) \tag{3}$$

$$I_{LED} \text{ (mA)} = 4920 * D / ((R_{SET} \text{ (k}\Omega) - 0.140 \text{ (k}\Omega)) \tag{4}$$

The modified LED current equation is more accurate in determining the actual LED current based on the RSET resistor value.

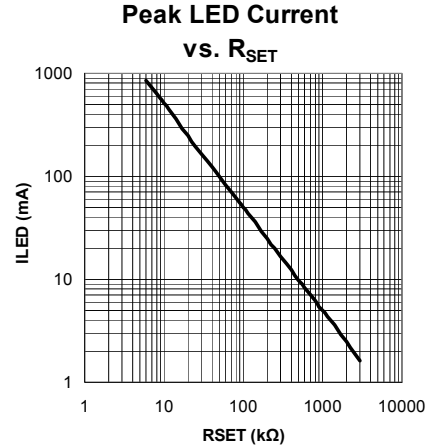

Figure 2. Peak LED Current vs. R_{SET}

D1

The D1 pins are the linear driver inputs for the LED. Connect the anode of the LED to V_{IN} and the cathode to the D1 pins. All the D1 pins must be connected together. The D1 voltage at dropout is the minimum voltage required by the linear driver in order for the LED to be fully biased.

GND

The ground pin is the ground path for the linear driver. The ground of the input capacitor should be routed with low impedance traces to the GND pin and made as short as possible. Refer to the layout recommendations for more details.

Application Information

Ultra Fast PWM™ Dimming Interface

The MIC4801 supports a wide range of PWM control signal frequencies from 200Hz to 500kHz. This extremely wide range of control provides ultimate flexibility for handheld applications using high frequency PWM control signals.

WLED dimming is achieved by applying a pulse width modulated (PWM) signal to the EN pin. For PWM frequencies between 200Hz – 10kHz the MIC4801 supports a duty cycle range from 1% to 100%, as shown in Figure 3. The MIC4801 incorporates an internal shutdown delay to ensure that the internal control circuitry remains active during PWM dimming. This feature prevents the possibility of backlight flickering when using low frequency PWM control signals. The MIC4801 also supports Ultra Fast PWM™ frequencies from 20kHz to 500kHz. Due to input signal propagation delay, PWM frequencies above 20kHz have a non-linear relationship between the duty cycle and the average LED current, as shown in Figure 3 and 4. Figures 6 through 9 show the WLED current response when a PWM signal is applied to the EN pin ⁽¹⁾.

⁽¹⁾ From the low I_Q sleep mode higher PWM frequencies require a logic high enable signal for 60μs to first enable the MIC4801 prior to PWM dimming.

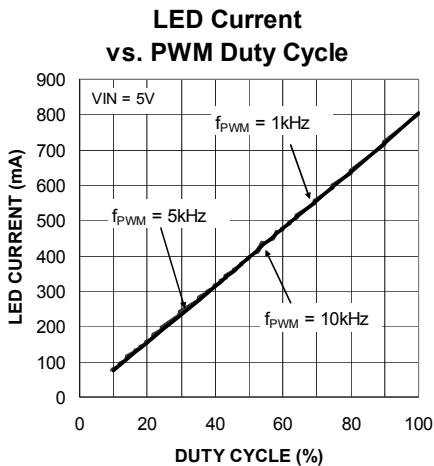

Figure 3. Average Current per LED Dimming by Changing PWM Duty Cycle for PWM Frequencies up to 20kHz

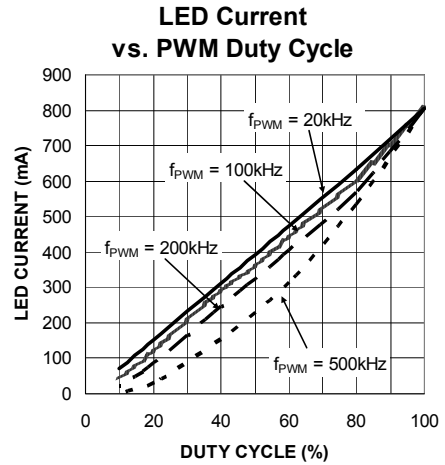

Figure 4. Channel Current Response to PWM Control Signal Frequencies from 50kHz to 500kHz

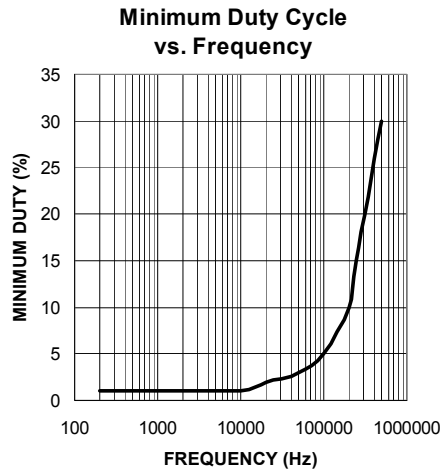

Figure 5. Minimum Duty Cycle for Varying PWM Frequency

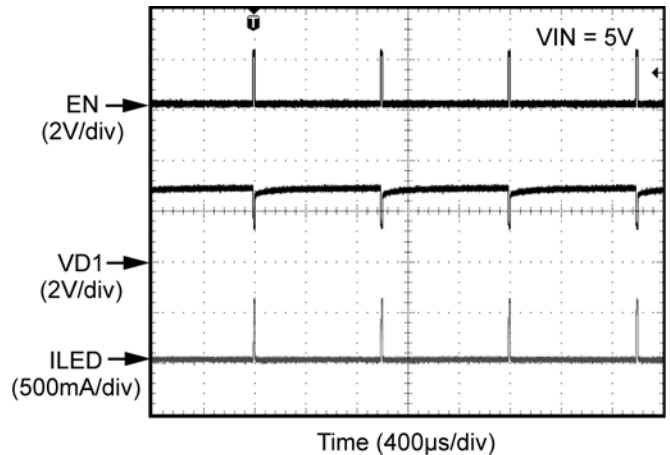

Figure 6. PWM Signal at 1% Duty Cycle (I_{avg} = 6mA)

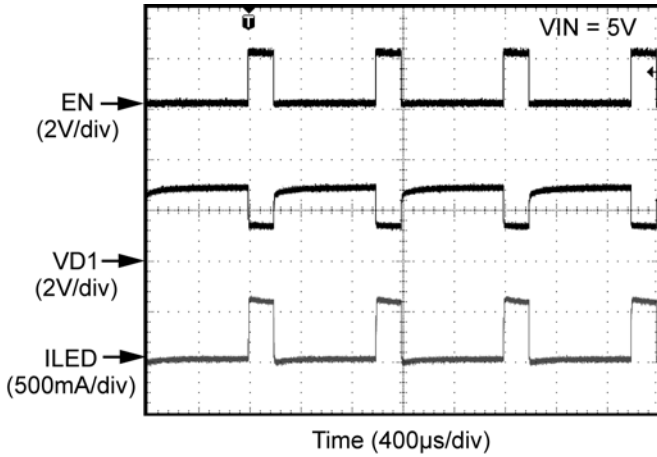

Figure 7. PWM Signal at 20% Duty Cycle ($I_{avg} = 120mA$)

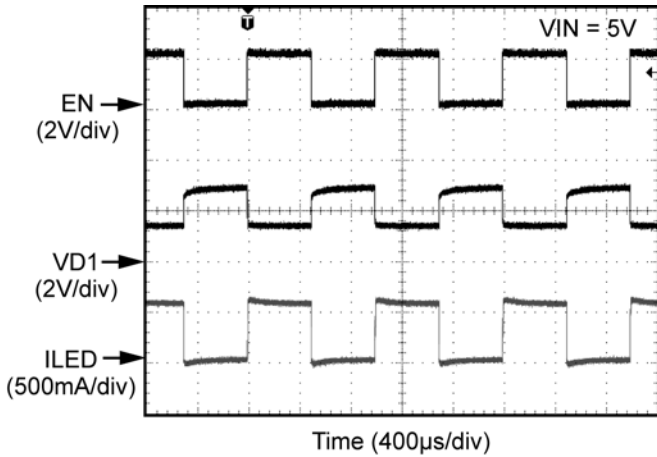

Figure 8. PWM Signal at 50% Duty Cycle ($I_{avg} = 300mA$)

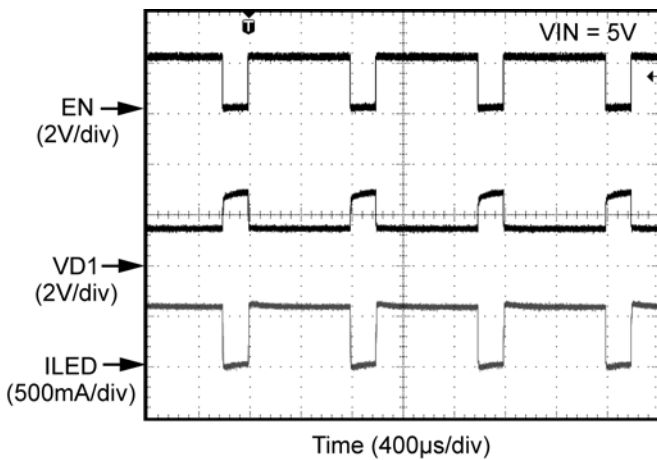

Figure 9. PWM Signal at 80% Duty Cycle ($I_{avg} = 480mA$)

Thermal Consideration

The MIC4801 thermal considerations involve calculating the junction temperature based on the voltage drop across the package and the LED current. The voltage drop across the package is equal to the voltage at D1 with respect to ground times the LED current.

$$P_{LOSS} = I_{LED} * V_{D1}$$

The temperature rise (ΔT) is calculated:

$$\Delta T = P_{LOSS} * \theta_{JA}$$

Assuming the I_{LED} is 600mA and V_{D1} is 500mV at 20°C room temperature, we can calculate the junction temperature:

$$T_J = T_A + \Delta T$$

$$T_J = 20^\circ C + 0.3W * 98.9^\circ C/W$$

$$T_J = 20^\circ C + 29.7^\circ C = 49.7^\circ C$$

The junction temperature will be around 49.7°C.

MIC4801 Typical Application Circuit

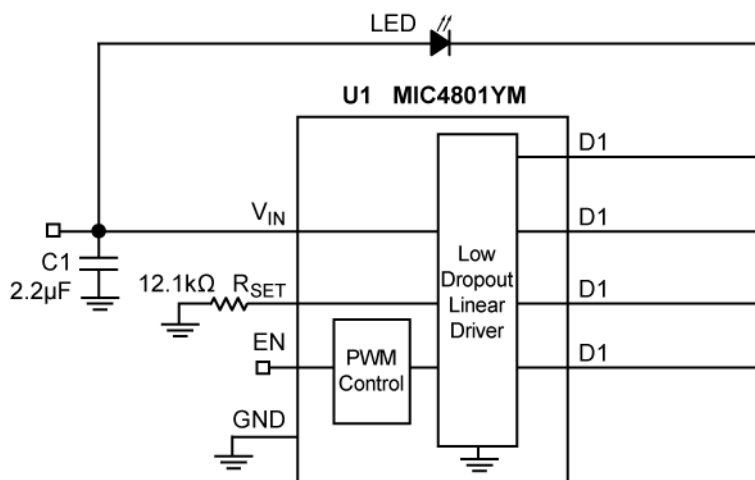

Bill of Materials

Item	Part Number	Manufacturer	Description	Qty.
C1	C1608X5R0J225K	TDK ⁽¹⁾	Ceramic Capacitor, 2.2µF, 6.3V, X5R, Size 0603	1
	06036D225KAT2A	AVX ⁽²⁾		
	GRM188R60J225KE19D	Murata ⁽³⁾		
	VJ0603G225KXYAT	Vishay ⁽⁴⁾		
LED	R42180	Seoul Semiconductor ⁽⁵⁾	3.8W High Power WLED	1
R1	CRCW060312K1FKEA	Vishay ⁽⁴⁾	Resistor, 1%, 1/16W, Size 0603	1
U1	MIC4801YM	Micrel, Inc. ⁽⁶⁾	600mA Single Channel Ultra Fast PWM™ Linear WLED Driver	1

Notes:

1. TDK: www.tdk.com
2. AVX: www.avx.com
3. Murata: www.murata.com
4. Vishay: www.vishay.com
5. Seoul Semi: <http://www.acriche.com/en>
6. Micrel, Inc.: www.micrel.com

Layout Recommendations

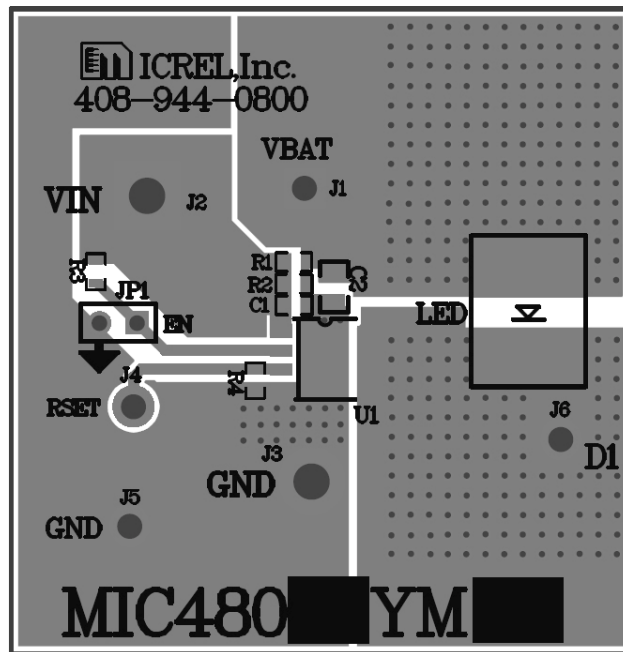

Top Layer

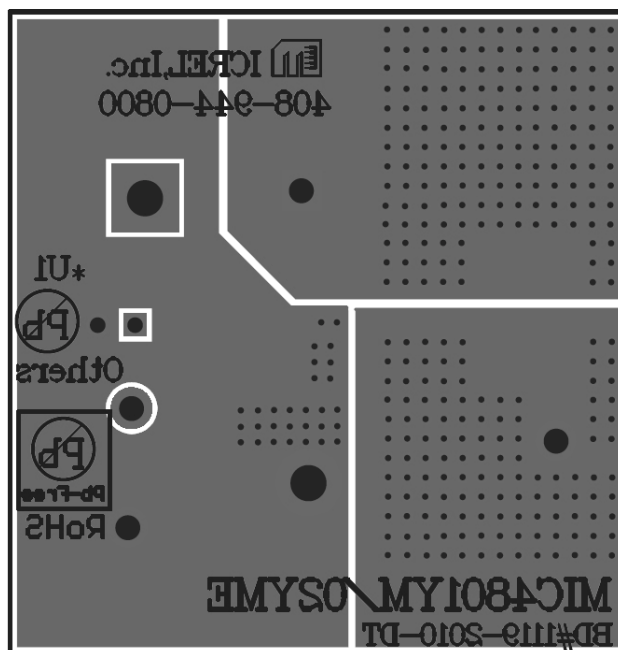

Bottom Layer

Package Information

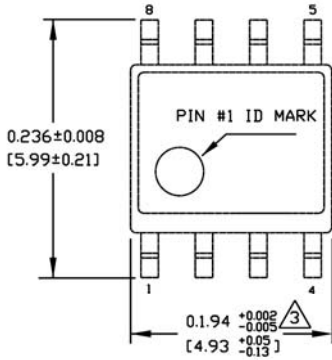

TOP VIEW

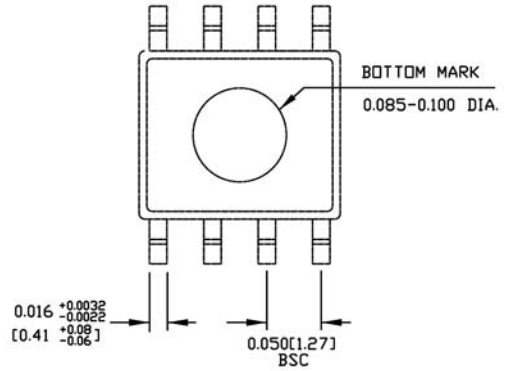

BOTTOM VIEW

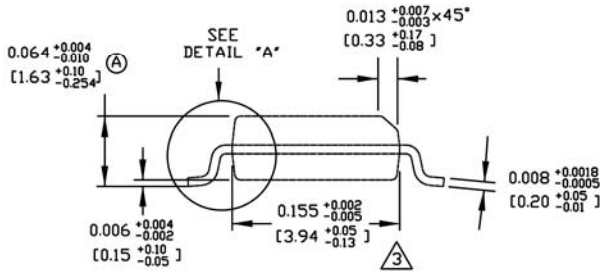

END VIEW

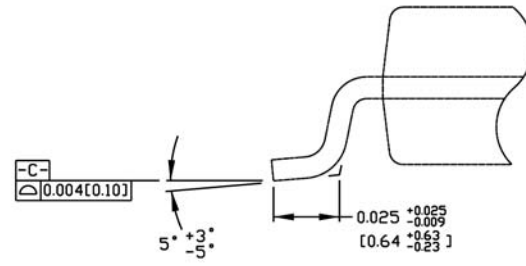

DETAIL *A*

8-Pin SOIC (M)

MICREL, INC. 2180 FORTUNE DRIVE SAN JOSE, CA 95131 USA
 TEL +1 (408) 944-0800 FAX +1 (408) 474-1000 WEB <http://www.micrel.com>

Micrel makes no representations or warranties with respect to the accuracy or completeness of the information furnished in this data sheet. This information is not intended as a warranty and Micrel does not assume responsibility for its use. Micrel reserves the right to change circuitry, specifications and descriptions at any time without notice. No license, whether express, implied, arising by estoppel or otherwise, to any intellectual property rights is granted by this document. Except as provided in Micrel's terms and conditions of sale for such products, Micrel assumes no liability whatsoever, and Micrel disclaims any express or implied warranty relating to the sale and/or use of Micrel products including liability or warranties relating to fitness for a particular purpose, merchantability, or infringement of any patent, copyright or other intellectual property right.

Micrel Products are not designed or authorized for use as components in life support appliances, devices or systems where malfunction of a product can reasonably be expected to result in personal injury. Life support devices or systems are devices or systems that (a) are intended for surgical implant into the body or (b) support or sustain life, and whose failure to perform can be reasonably expected to result in a significant injury to the user. A Purchaser's use or sale of Micrel Products for use in life support appliances, devices or systems is a Purchaser's own risk and Purchaser agrees to fully indemnify Micrel for any damages resulting from such use or sale.

Компания «Океан Электроники» предлагает заключение долгосрочных отношений при поставках импортных электронных компонентов на взаимовыгодных условиях!

Наши преимущества:

- Поставка оригинальных импортных электронных компонентов напрямую с производств Америки, Европы и Азии, а так же с крупнейших складов мира;
- Широкая линейка поставок активных и пассивных импортных электронных компонентов (более 30 млн. наименований);
- Поставка сложных, дефицитных, либо снятых с производства позиций;
- Оперативные сроки поставки под заказ (от 5 рабочих дней);
- Экспресс доставка в любую точку России;
- Помощь Конструкторского Отдела и консультации квалифицированных инженеров;
- Техническая поддержка проекта, помощь в подборе аналогов, поставка прототипов;
- Поставка электронных компонентов под контролем ВП;
- Система менеджмента качества сертифицирована по Международному стандарту ISO 9001;
- При необходимости вся продукция военного и аэрокосмического назначения проходит испытания и сертификацию в лаборатории (по согласованию с заказчиком);
- Поставка специализированных компонентов военного и аэрокосмического уровня качества (Xilinx, Altera, Analog Devices, Intersil, Interpoint, Microsemi, Actel, Aeroflex, Peregrine, VPT, Syfer, Eurofarad, Texas Instruments, MS Kennedy, Miteq, Cobham, E2V, MA-COM, Hittite, Mini-Circuits, General Dynamics и др.);

Компания «Океан Электроники» является официальным дистрибьютором и эксклюзивным представителем в России одного из крупнейших производителей разъемов военного и аэрокосмического назначения «JONHON», а так же официальным дистрибьютором и эксклюзивным представителем в России производителя высокотехнологичных и надежных решений для передачи СВЧ сигналов «FORSTAR».



JONHON

«JONHON» (основан в 1970 г.)

Разъемы специального, военного и аэрокосмического назначения:

(Применяются в военной, авиационной, аэрокосмической, морской, железнодорожной, горно- и нефтедобывающей отраслях промышленности)

«FORSTAR» (основан в 1998 г.)

ВЧ соединители, коаксиальные кабели, кабельные сборки и микроволновые компоненты:

(Применяются в телекоммуникациях гражданского и специального назначения, в средствах связи, РЛС, а так же военной, авиационной и аэрокосмической отраслях промышленности).



Телефон: 8 (812) 309-75-97 (многоканальный)

Факс: 8 (812) 320-03-32

Электронная почта: ocean@oceanchips.ru

Web: <http://oceanchips.ru/>

Адрес: 198099, г. Санкт-Петербург, ул. Калинина, д. 2, корп. 4, лит. А