

TLE6251D

High Speed CAN-Transceiver with bus wake-up



Features

- Fully compatible with ISO 11898-2 / -5
- Wide common mode range for electromagnetic immunity (EMI)
- Very low electromagnetic emission (EME)
- Excellent ESD immunity
- Extended supply range on V_{CC} and V_{IO}
- V_{IO} input for voltage adaption to the microcontroller supply
- CAN short-circuit proof to ground, battery and V_{CC}
- TxD time-out function
- Low CAN bus leakage current in power-down state
- Overtemperature protection
- Protected against automotive transients
- CAN data transmission rate up to 1 Mbps
- Stand-by mode with remote wake-up function
- Wake-up detection by signal change on the RxD output
- Power Supply V_{CC} can be turned off in stand-by mode
- Green Product (RoHS compliant)

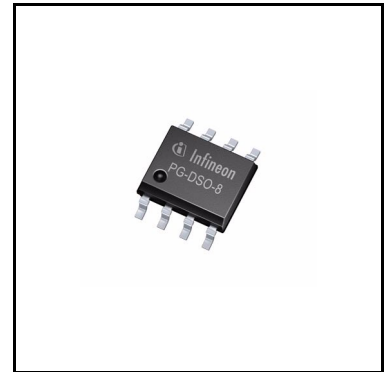

Potential applications

- Gateway modules
- Body control modules (BCMs)
- Electric power steering
- Battery management systems
- Cluster and lighting control modules

Product validation

Qualified for automotive applications. Product validation according to AEC-Q100.

Description

The TLE6251D is a transceiver designed for CAN networks in automotive and industrial applications. As an interface between the physical bus layer and the CAN protocol controller, the TLE6251D drives the signals to the bus and protects the microcontroller against interferences generated within the network. Based on the

high symmetry of the CANH and CANL signals, the TLE6251D provides a very low level of electromagnetic emission (EME) within a wide frequency range. The TLE6251D is integrated into a RoHS compliant PG-DSO-8 package and fulfills or exceeds the requirements of the ISO11898-2 / -5.

The TLE6251D allows very low quiescent currents in stand-by mode while the device is still able to wake-up by a bus signal on the CAN bus. Based on the very low leakage currents on the CAN bus interface the TLE6251D provides an excellent passive behavior in power-down state. These and other features make the TLE6251D especially suitable for mixed supply CAN networks.

Based on the Infineon Smart Power Technology SPT, the TLE6251D provides excellent ESD immunity together with a very high electromagnetic immunity (EMI). The TLE6251D and the Infineon SPT technology are AEC qualified and tailored to withstand the harsh conditions of the Automotive Environment.

Two different operation modes, additional fail-safe features like a TxD time-out, and the optimized output slew rates on the CANH and CANL signals make the TLE6251D the ideal choice for large CAN networks with high data transmission rates.

Type	Package	Marking
TLE6251D	PG-DSO-8	6251D

Table of contents

	Features	1
	Potential applications	1
	Product validation	1
	Description	1
	Table of contents	3
1	Block diagram	4
2	Pin configuration	5
2.1	Pin assignment	5
2.2	Pin definitions	5
3	Functional description	7
3.1	High speed CAN physical layer	7
3.2	Modes of operation	8
3.3	Normal-operating mode	10
3.4	Stand-by mode	10
3.5	Power-down state	10
3.6	Remote wake-up	11
3.7	Voltage adaption to the microcontroller supply	11
4	Fail safe functions	12
4.1	Short-circuit protection	12
4.2	Unconnected logical pins	12
4.3	TxD time-out function	12
4.4	Undervoltage detection	13
4.5	Overtemperature protection	14
4.6	Delay time for mode change	14
5	General product characteristics	15
5.1	Absolute maximum ratings	15
5.2	Functional range	16
5.3	Thermal resistance	16
6	Electrical characteristics	17
6.1	Functional device characteristics	17
6.2	Diagrams	20
7	Application information	22
7.1	ESD immunity according to IEC61000-4-2	22
7.2	Application example	23
7.3	Further application information	23
8	Package outlines	24
9	Revision history	25

Block diagram

1 Block diagram

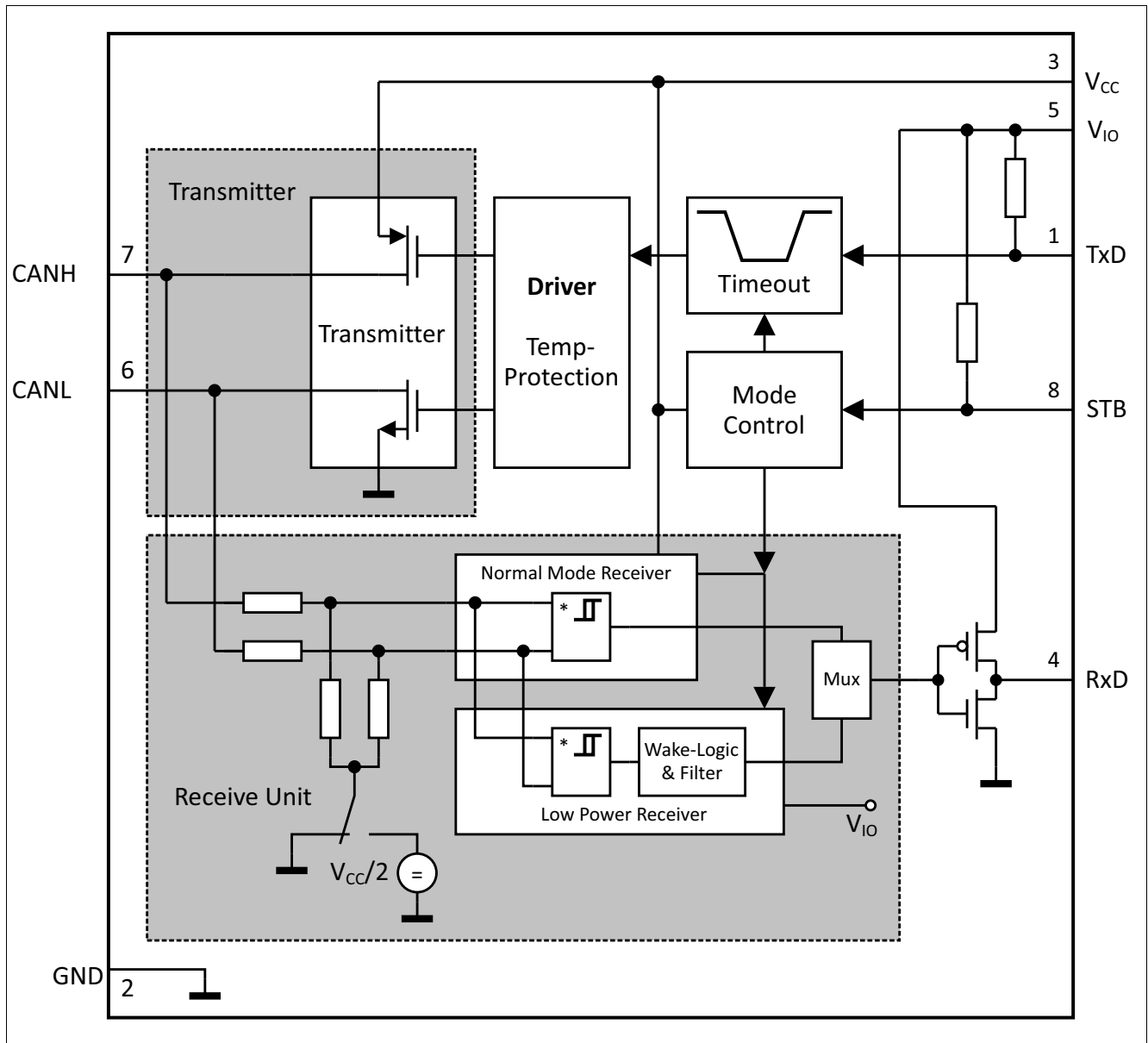

Figure 1 Block diagram

Pin configuration

2 Pin configuration

2.1 Pin assignment

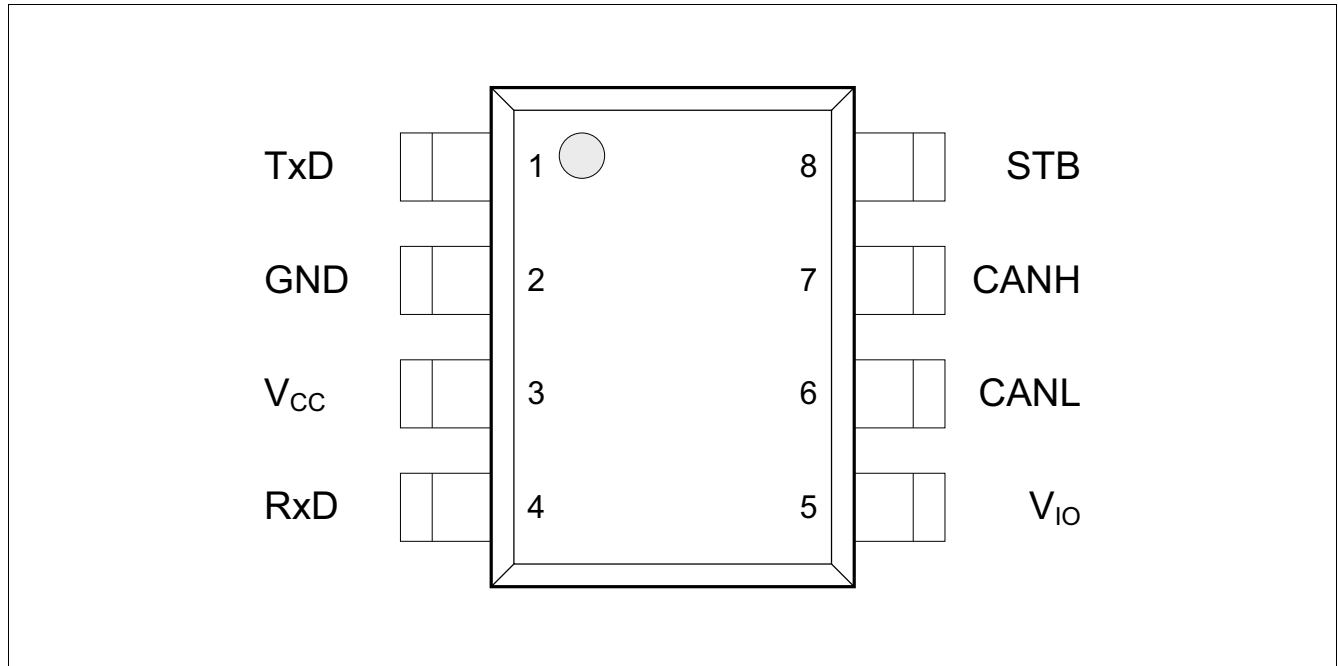

Figure 2 Pin configuration

2.2 Pin definitions

Table 1 Pin definitions and functions

Pin No.	Symbol	Function
1	TXD	Transmit data input Internal pull-up to V_{IO} , “low” for dominant state.
2	GND	Ground
3	V_{CC}	Transceiver supply voltage 100 nF decoupling capacitor to GND required, V_{CC} can be turned off in stand-by mode.
4	RxD	Receive data output; “Low” in dominant state.
5	V_{IO}	Digital supply voltage input Supply voltage input to adapt the logical input and output voltage levels of the transceiver to the microcontroller supply. Supply for the low-power receiver. 100 nF decoupling capacitor to GND required.
6	CANL	CAN bus low level I/O “Low” in dominant state.

Pin configuration

Table 1 Pin definitions and functions (cont'd)

Pin No.	Symbol	Function
7	CANH	CAN bus high level I/O “High” in dominant state.
8	STB	Stand-by input Internal pull-up to V_{IO} , “low” for normal-operating mode.

Functional description

3 Functional description

CAN is a serial bus system that connects microcontrollers, sensors and actuators for real-time control applications. The use of the Controller Area Network (abbreviated CAN) within road vehicles is described by the international standard ISO 11898. According to the 7-layer OSI reference model, the physical layer of a CAN bus system specifies the data transmission from one CAN node to all other available CAN nodes within the network. The physical layer specification of a CAN bus system includes all electrical and mechanical specifications of a CAN network. The CAN transceiver is part of the physical layer specification. Several different physical layer standards of CAN networks have been developed in recent years. The TLE6251D is a High Speed CAN transceiver with a dedicated bus wake-up function and defined by the international standard ISO 11898-2.

3.1 High speed CAN physical layer

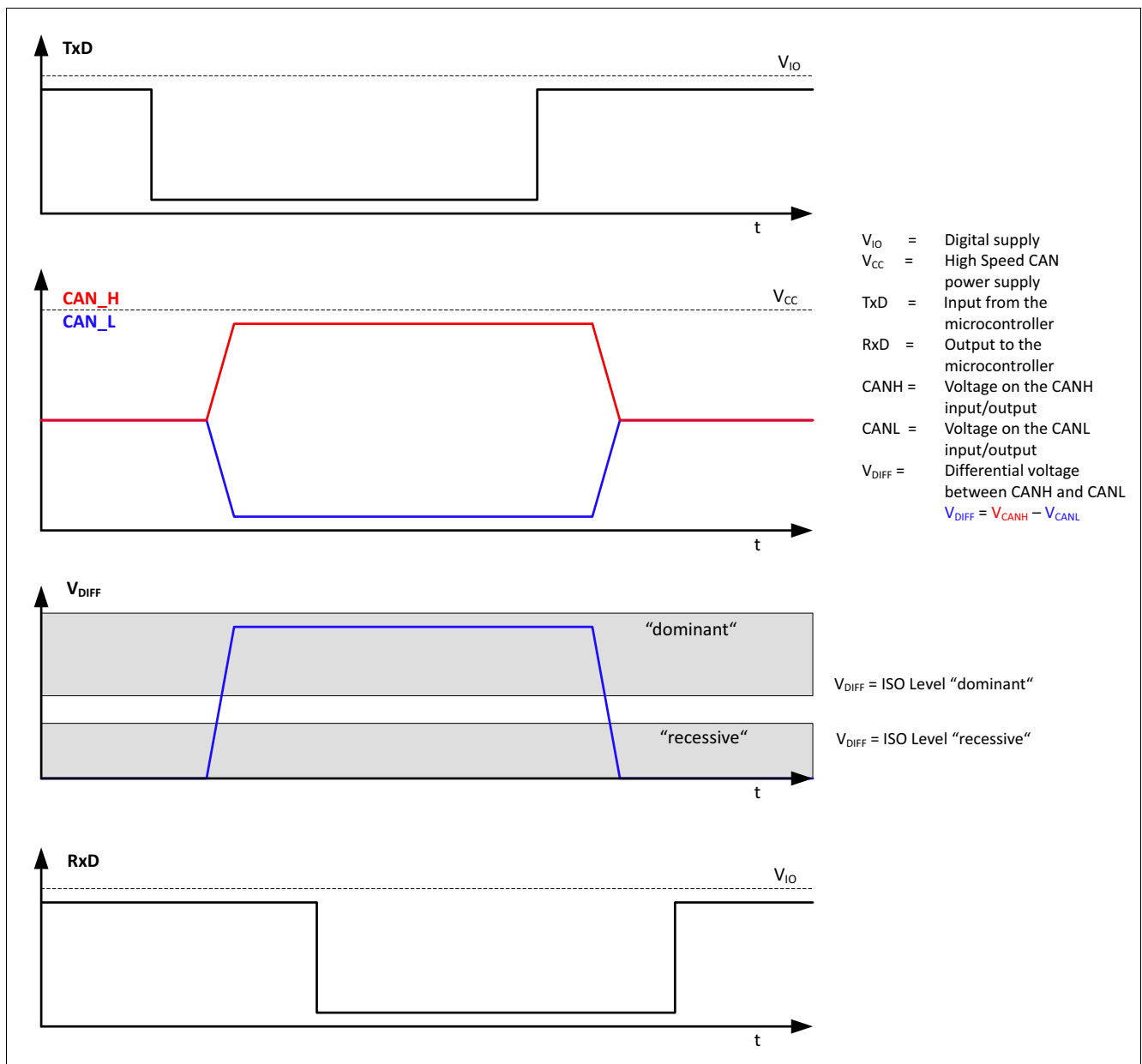

Figure 3 High speed CAN bus signals and logical signals

Functional description

The TLE6251D is a High Speed CAN transceiver, operating as an interface between the CAN controller and the physical bus medium. A HS CAN network is a two-wire, differential network, which allows data transmission rates up to 1 Mbps. The characteristics for a HS CAN network are the two signal states on the CAN bus: dominant and recessive (see [Figure 3](#)).

The CANH and CANL pins are the interface to the CAN bus and both pins operate as an input and output. The RxD and TxD pins are the interface to the microcontroller. The TxD pin is the serial data input from the CAN controller, the RxD pin is the serial data output to the CAN controller. As shown in [Figure 1](#), the HS CAN transceiver TLE6251D includes a receiver and a transmitter unit, allowing the transceiver to send data to the bus medium and monitor the data from the bus medium at the same time. The HS CAN transceiver TLE6251D converts the serial data stream which is available on the transmit data input TxD, into a differential output signal on the CAN bus, provided by the pins CANH and CANL. The receiver stage of the TLE6251D monitors the data on the CAN bus and converts them to a serial, single-ended signal on the RxD output pin. A logical “low” signal on the TxD pin creates a dominant signal on the CAN bus, followed by a logical “low” signal on the RxD pin (see [Figure 3](#)). The feature, broadcasting data to the CAN bus and listening to the data traffic on the CAN bus simultaneously is essential to support the bit-to-bit arbitration within CAN networks.

The voltage levels for HS CAN transceivers are defined by the ISO 11898-2 and the ISO 11898-5 standards. Whether a data bit is dominant or recessive depends on the voltage difference between the CANH and CANL pins: $V_{DIFF} = V_{CANH} - V_{CANL}$.

In comparison with other differential network protocols, the amplitude of the differential signal on a CAN network can only be higher than or equal to 0 V. To transmit a dominant signal to the CAN bus, the amplitude of the differential signal V_{DIFF} is higher than or equal to 1.5 V. To receive a recessive signal from the CAN bus, the amplitude of the differential V_{DIFF} is lower than or equal to 0.5 V.

“Partially-supplied” High Speed CAN networks are networks in which the CAN bus nodes of one common network have different power supply conditions. Some nodes are connected to the common power supply, while other nodes are disconnected from the power supply and in power-down state. Regardless of whether the CAN bus subscriber is supplied or not, each subscriber connected to the common bus media must not interfere with the communication. The TLE6251D is designed to support “partially-supplied” networks. In the power-down state, the receiver input resistors are switched off and the transceiver input has a high resistance. For permanently supplied ECUs, the HS CAN transceiver TLE6251D provides a stand-by mode. In stand-by mode, the power consumption of the TLE6251D is optimized to a minimum, while the device is still able to recognize wake-up patterns on the CAN bus and signal a wake-up event to the external microcontroller.

The voltage level on the digital input TxD and the digital output RxD is determined by the power supply level at the V_{IO} pin. Depending on the voltage level at the V_{IO} pin, the signal levels on the logic pins (STB, TxD and RxD) are compatible with microcontrollers having a 5 V or 3.3 V I/O supply. Usually, the V_{IO} power supply of the transceiver is connected to the same power supply as the I/O power supply of the microcontroller.

3.2 Modes of operation

Two different modes of operation are available on the TLE6251D. Each mode has specific characteristics in terms of quiescent current or data transmission. The digital input pin STB is used for the mode selection. [Figure 4](#) illustrates the different mode changes depending on the status of the STB pin. After supplying V_{CC} and V_{IO} to the HS CAN transceiver, the TLE6251D starts in stand-by mode. The internal pull-up resistor at the STB pin sets the TLE6251D to stand-by mode by default. If the microcontroller is up and running, the TLE6251D can switch to any operating mode within the time period for mode change t_{MODE} .

Functional description

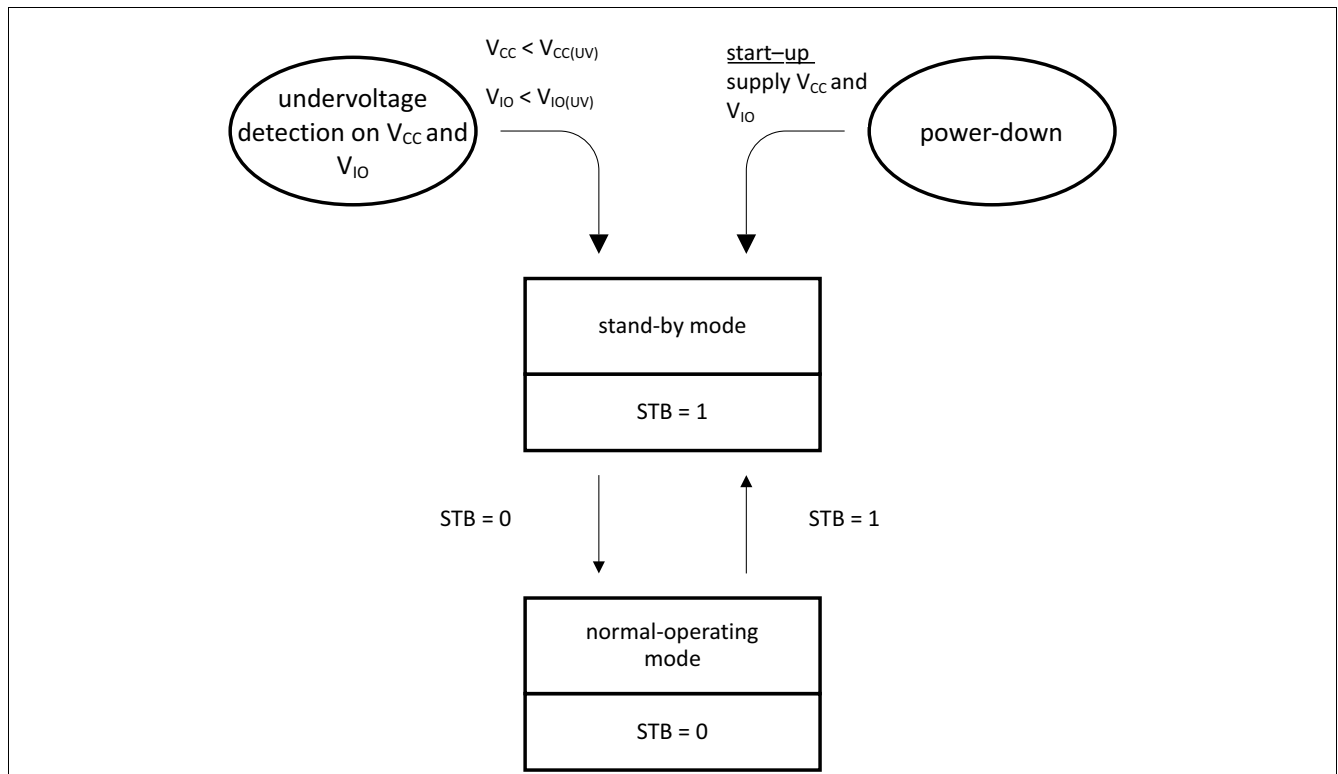

Figure 4 Mode of operation

The TLE6251D has 2 major modes of operation:

- Stand-by mode
- Normal-operating mode

Table 2 Modes of operation

Mode	STB	Bus Bias	Comment
Normal-operating mode	“low”	$V_{CC}/2$	The transmitter is active. The normal mode receiver is active. The low-power receiver is disabled.
Stand-by mode V_{CC} on V_{IO} on	“high”	GND	The transmitter is disabled. The normal mode receiver is disabled. The low-power receiver is active.
Stand-by mode V_{CC} off V_{IO} on	“high”	GND	The transmitter is disabled. The normal mode receiver is disabled. The low-power receiver is active.
Power-down state V_{CC} off V_{IO} off	Don't care	Floating	The transmitter is disabled. The normal mode receiver is disabled. The low-power receiver is disabled.

Functional description

3.3 Normal-operating mode

In the normal-operating mode, the HS CAN transceiver TLE6251D sends the serial data stream on the TxD pin to the CAN bus. The data on the CAN bus is displayed at the RxD pin simultaneously. In normal-operating mode, all functions of the TLE6251D are active:

- The transmitter is active and drives data from the TxD to the CAN bus.
- The receiver is active and provides the data from the CAN bus to the RxD pin.
- The low-power receiver is disabled.
- The bus basing is set to $V_{CC}/2$.
- The undervoltage monitoring on the power supply V_{CC} and on the power supply V_{IO} is active.
- The overtemperature protection is active.

To enter the normal-operating mode, set the STB pin to logical “low” (see [Table 2](#) or [Figure 4](#)). The STB pin has an internal pull-up resistor to the power-supply V_{IO} .

3.4 Stand-by mode

Stand-by mode is an idle mode of the TLE6251D with optimized power consumption. In stand-by mode, the TLE6251D can not send or receive any data. The normal mode receiver is switched off and only the low-power receiver is active. An additional filter, implemented inside the low-power receiver ensures that only dominant and recessive signals on the CAN bus, which are longer than the bus wake-up time t_{WU} are indicated at the RxD output pin.

- The transmitter is disabled, and permanently recessive.
- The input TxD is disabled.
- The normal mode receiver is disabled.
- The low-power receiver is active.
- The RxD output is “high”, in case no wake-up signal on the CAN bus is detected (see [Figure 5](#)).
- The RxD output toggles according to the wake-up signal on the CAN bus (see [Figure 5](#)).
- The undervoltage monitoring on the power supply V_{CC} is disabled.
- The undervoltage monitoring on the power supply V_{IO} is active.
- The bus biasing is set to GND.
- The overtemperature protection is not active.

To enter the stand-by mode, set the pin STB to logical “high” (see [Table 2](#) or [Figure 4](#)). The STB pin has an internal pull-up resistor to the power-supply V_{IO} . In case the stand-by mode is not be used in the final application, the STB pin needs to get connected to GND.

3.5 Power-down state

The power-down state means that the TLE6251D is not supplied. In the power-down state, the differential input resistors of the receiver are switched off. The CANH and CANL bus interface of the TLE6251D acts as a high- impedance input with a very small leakage current. The high-ohmic input does not influence the recessive level of the CAN network and allows an optimized EME performance of the entire CAN network.

Functional description

3.6 Remote wake-up

The TLE6251D has a remote wake-up feature, also called bus wake-up feature. In stand-by mode, the low-power receiver monitors the activity on the CAN bus and in case it detects a wake-up signal, the TLE6251D indicates the wake-up signal on the RxD output pin.

CAN bus signals, dominant or recessive, with a pulse width above the bus wake-up time $t > t_{WU}$ are indicated on the RxD output pin (see **Figure 5**).

The wake-up logic is supplied by the power supply V_{IO} (see **Figure 1**). In case the TLE6251D is in stand-by mode, the power supply V_{CC} can be turned off, while the TLE6251D is still able to detect the wake-up pattern on the CAN bus.

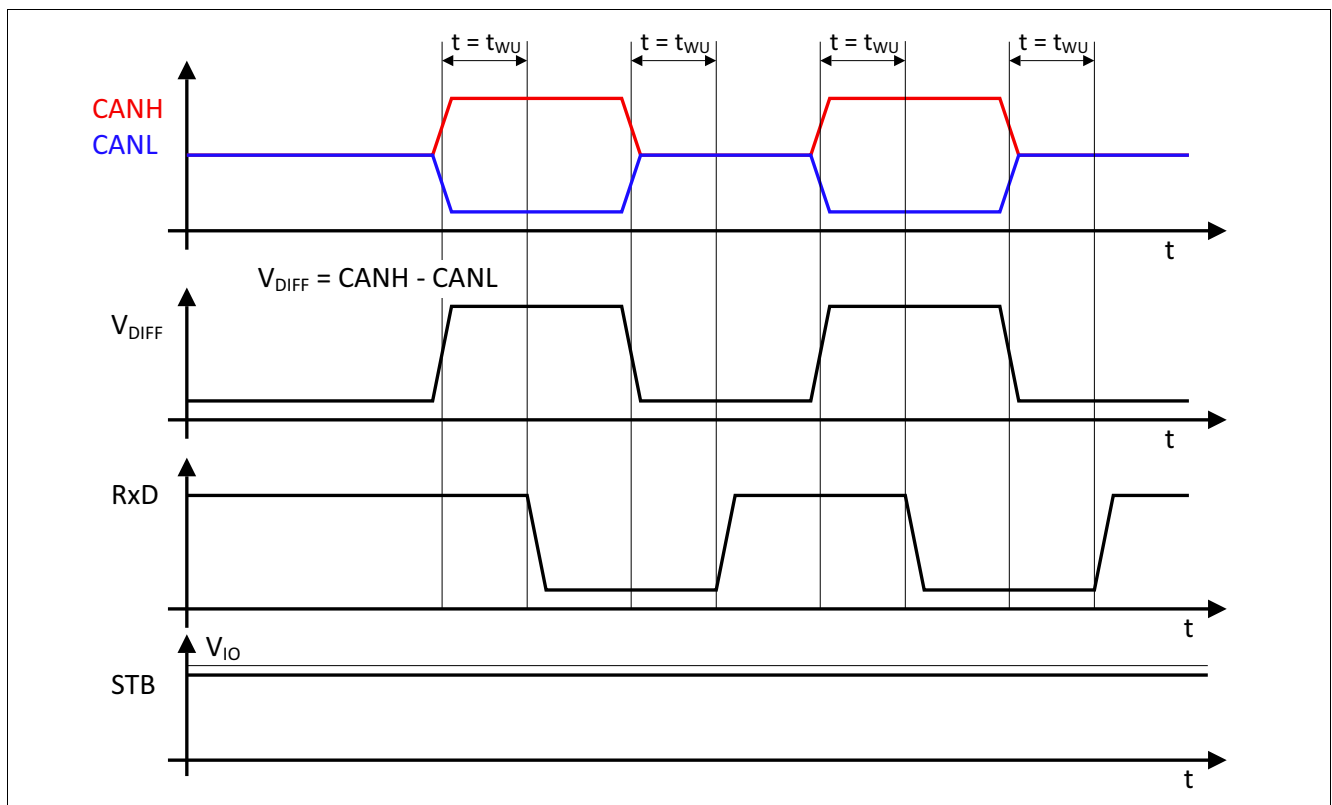

Figure 5 Wake-up pattern

3.7 Voltage adaption to the microcontroller supply

The HS CAN transceiver TLE6251D has two different power supplies, V_{CC} and V_{IO} . The power supply V_{CC} supplies the transmitter and the normal mode receiver, the power supply V_{IO} supplies the digital input and output buffers, the low-power receiver and the wake-up logic. To adjust the digital input and output levels of the TLE6251D to the I/O levels of the external microcontroller, the power supply V_{IO} should be connected to the microcontroller pad supply (see **Figure 11**).

Supplying the low-power receiver by the V_{IO} pin allows to switch off the V_{CC} supply in stand-by mode and leads to an additional reduction of the quiescent current in stand-by mode.

Fail safe functions

4 Fail safe functions

4.1 Short-circuit protection

The CANH and CANL bus outputs are short-circuit proof, either against GND or a positive supply voltage. A current limiting circuit protects the transceiver against damages. If the device heats up due to a continuous short on the CANH or CANL, the internal overtemperature protection switches off the bus transmitter.

4.2 Unconnected logical pins

All logical input pins have an internal pull-up resistor to V_{IO} . In case the V_{IO} supply is activated and the logical pins are open or floating, the TLE6251D enters the stand-by mode by default. In stand-by mode, the transmitter of the TLE6251D is disabled, the bus bias is turned off and the input resistors of CANH and CANL are connected to GND. The HS CAN transceiver TLE6251D will not influence the data on the CAN bus.

4.3 TxD time-out function

The TxD time-out feature protects the CAN bus against permanent blocking in case the logical signal on the TxD pin is continuously “low”. A continuous “low” signal on the TxD pin can have its root cause in a locked-up microcontroller or in a short on the printed circuit board, for example. In normal-operating mode, a logical “low” signal on the TxD pin for the time $t > t_{TxD}$ enables the TxD time-out feature and the TLE6251D disables the transmitter (see [Figure 6](#)). The receive unit is still active and the data on the bus continue to be monitored by the RxD output pin.

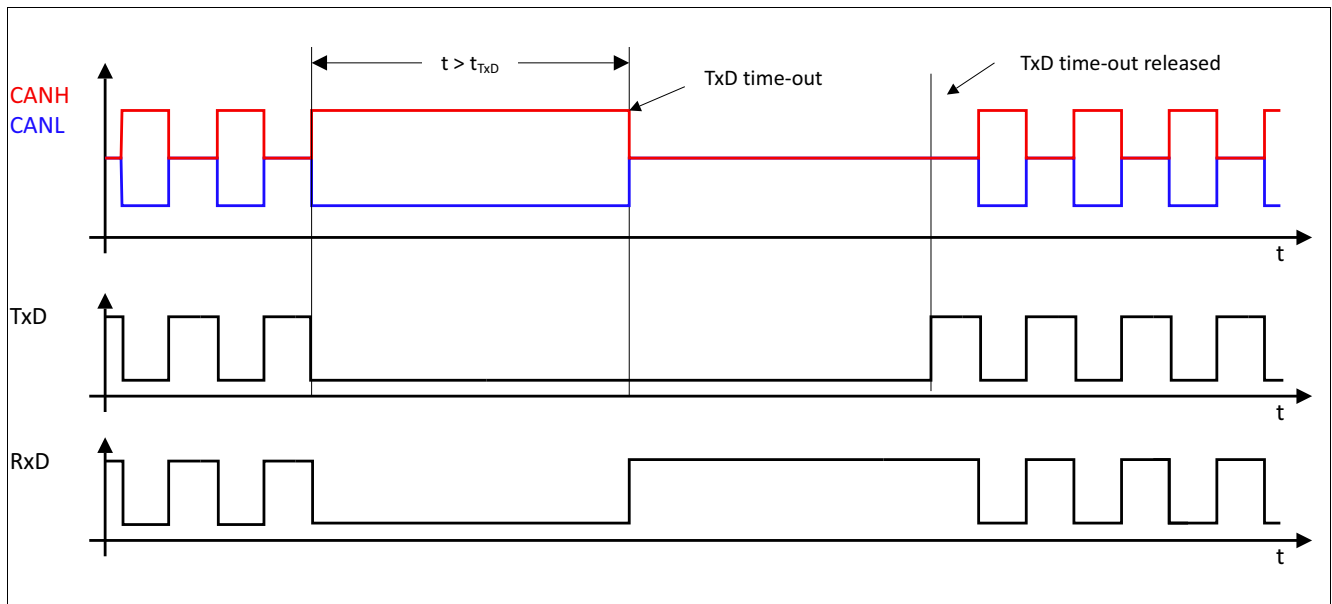

Figure 6 TxD time-out function

[Figure 6](#) shows how the transmitter is deactivated and re-activated again. A permanent “low” signal on the TxD input pin activates the TxD time-out function and deactivates the transmitter. To release the transmitter after a TxD time-out event, the TLE6251D requires a signal change on the TxD input pin from logical “low” to logical “high”.

Fail safe functions

4.4 Undervoltage detection

The HS CAN Transceiver TLE6251D is provided with undervoltage detection on the power supply V_{CC} and the power supply V_{IO} . Both undervoltage detection monitors are active in normal-operating mode. In stand-by mode only the V_{IO} undervoltage monitoring is active, the V_{CC} undervoltage monitoring is disabled.

In case the power supply V_{CC} or V_{IO} drops below a voltage level where the transceiver TLE6251D cannot securely send data to the bus or receive data from the bus, the undervoltage detection disables the data communication (see [Figure 7](#)).

The transmitter and the receiver are disabled, but the bus biasing remains connected to $V_{CC}/2$. With a falling V_{CC} supply, the recessive level of the CAN bus signal decreases respectively.

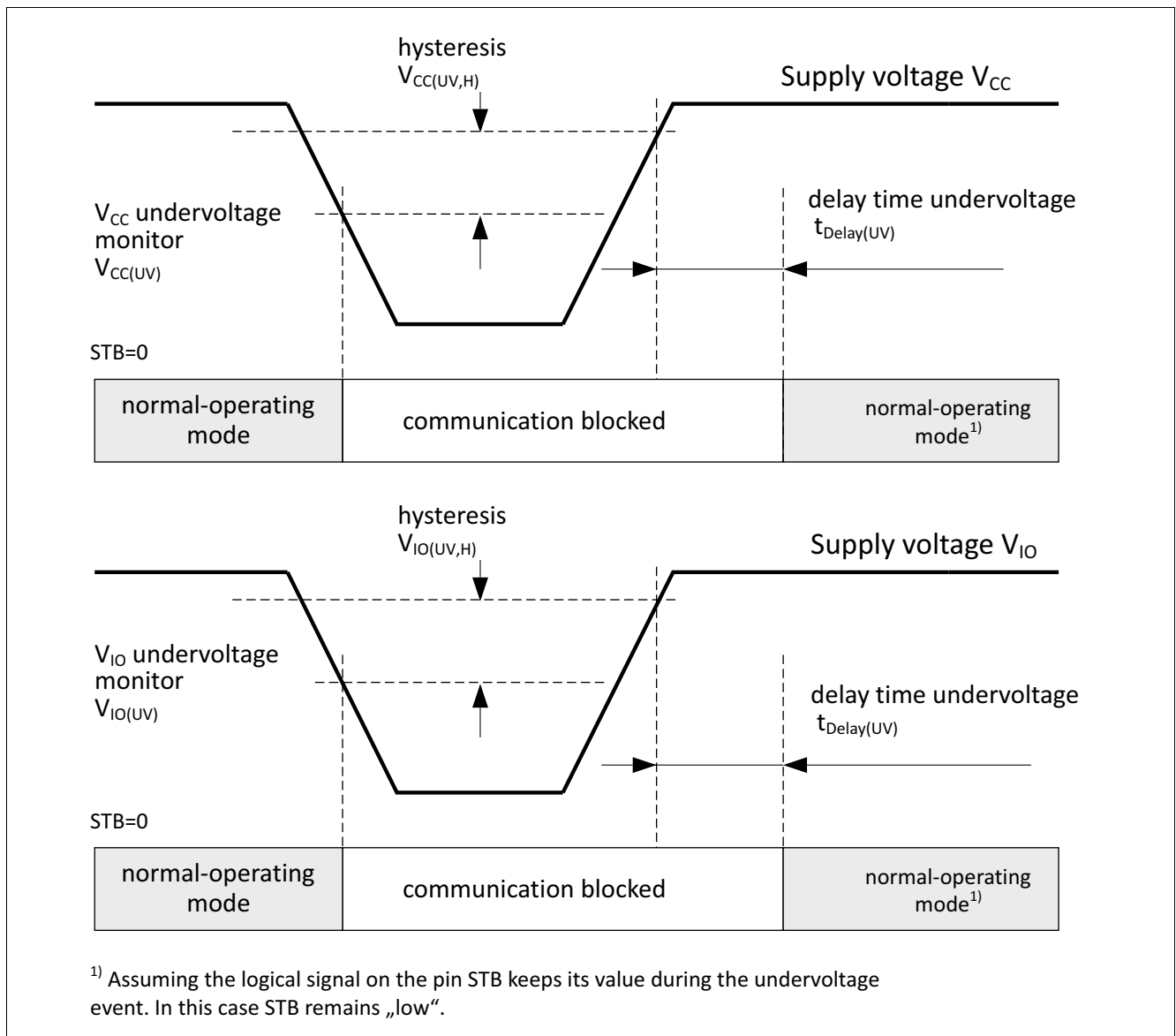

Figure 7 Undervoltage detection on V_{CC} or V_{IO}

Fail safe functions

4.5 Overtemperature protection

The TLE6251D has an integrated overtemperature detection circuit to protect the TLE6251D against thermal overstress of the transmitter. The overtemperature protection is active in normal-operating mode and disabled in stand-by mode. In case of an overtemperature condition, the temperature sensor will disable the transmitter (see **Figure 1**) while the transceiver remains in normal-operating mode.

After the device cools down the transmitter is activated again (see **Figure 8**). A hysteresis is implemented within the temperature sensor.

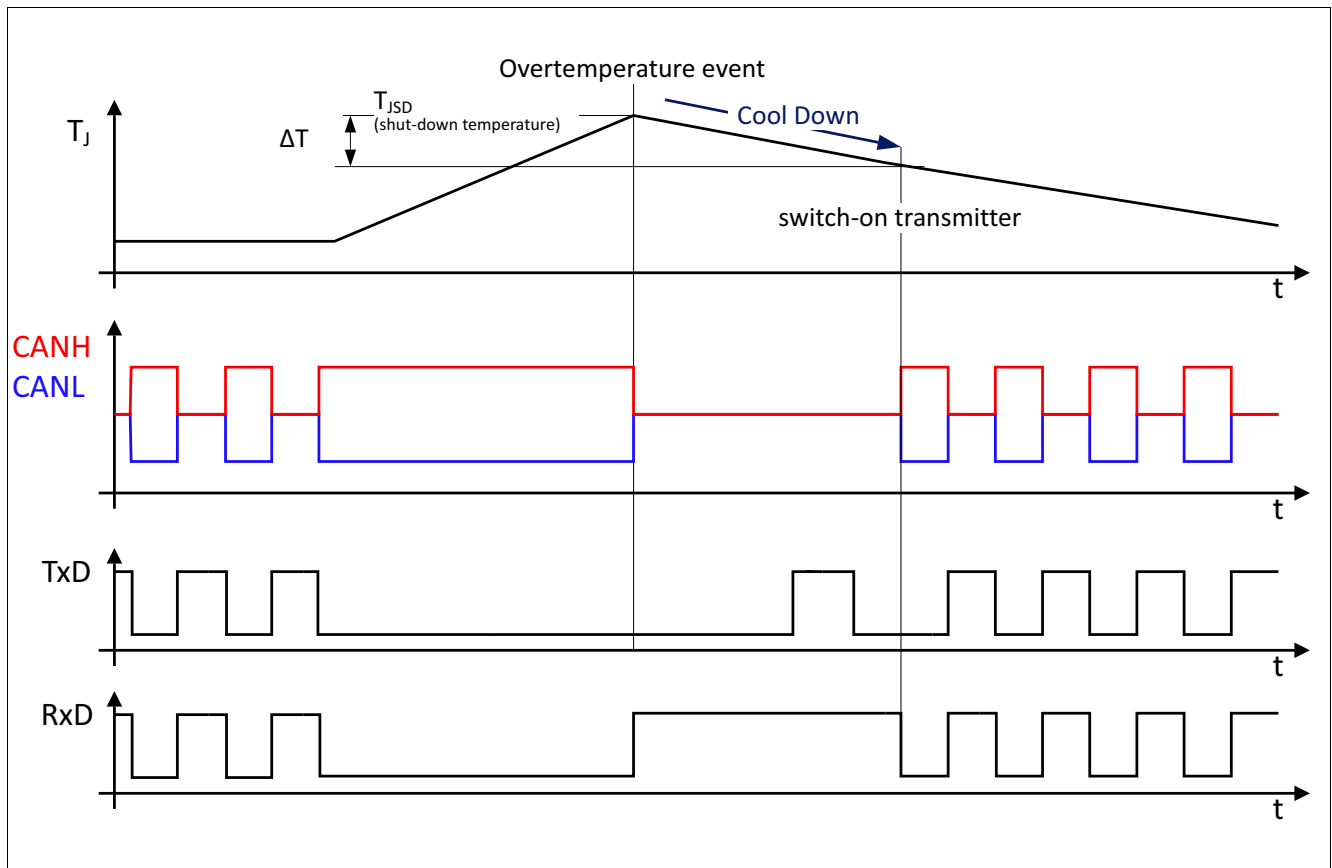

Figure 8 Overtemperature protection

4.6 Delay time for mode change

During the mode change from stand-by mode to normal-operating mode or vice versa, the internal receive unit switches from the low-power receiver to the normal mode receiver and vice versa. In order to avoid any bit toggling on the RxD output pin, the RxD output is set to logical “high” during the mode change for the time t_{Mode} and is not reflecting the signal on the CAN bus.

General product characteristics

5 General product characteristics

5.1 Absolute maximum ratings

Table 3 Absolute maximum ratings voltages, currents and temperatures¹⁾

All voltages with respect to ground; positive current flowing into pin(unless otherwise specified)

Parameter	Symbol	Values			Unit	Note or Test Condition	Number
		Min.	Typ.	Max.			
Voltages							
Supply voltage	V_{CC}	-0.3	–	6.0	V	–	P_6.1.1
Logic supply voltage	V_{IO}	-0.3	–	6.0	V	–	P_6.1.2
CANH DC voltage versus GND	V_{CANH}	-40	–	40	V	–	P_6.1.3
CANL DC voltage versus GND	V_{CANL}	-40	–	40	V	–	P_6.1.4
Differential voltage between CANH and CANL	$V_{CAN\ diff}$	-40	–	40	V	–	P_6.1.5
Logic voltages at logic input pins STB, TxD	V_{Max_in}	-0.3	–	6.0	V	–	P_6.1.6
Logic voltages at logic output pin RxD	V_{Max_Out}	-0.3	–	V_{IO}	V	–	P_6.1.7
Temperatures							
Junction temperature	T_j	-40	–	150	°C	–	P_6.1.8
Storage temperature	T_s	-55	–	150	°C	–	P_6.1.9
ESD resistivity							
ESD immunity at CANH, CANL versus GND	$V_{ESD_HBM_CAN}$	-8	–	8	kV	HBM (100 pF via 1.5 kΩ) ²⁾	P_6.1.10
ESD immunity at all other pins	$V_{ESD_HBM_ALL}$	-2	–	2	kV	HBM (100 pF via 1.5 kΩ) ²⁾	P_6.1.11
ESD immunity to GND	V_{ESD_CDM}	-750	–	750	V	CDM ³⁾	P_6.1.12

1) Not subject to production test, specified by design.

2) ESD susceptibility, Human Body Model “HBM” according to ANSI/ESDA/JEDEC JS-001.

3) ESD susceptibility, Charge Device Model “CDM” according to EIA/JESD22-C101 or ESDA STM5.3.1.

Notes

1. Stresses above the ones listed here may cause permanent damage to the device. Exposure to absolute maximum rating conditions for extended periods may affect device reliability.
2. Integrated protection functions are designed to prevent IC destruction under fault conditions described in the data sheet. Fault conditions are considered as “outside” normal operating range. Protection functions are not designed for continuous repetitive operation.

General product characteristics

5.2 Functional range

Table 4 Operating range

Parameter	Symbol	Values			Unit	Note or Test Condition	Number
		Min.	Typ.	Max.			
Supply voltages							
Transceiver supply voltage	V_{CC}	4.5	–	5.5	V	–	P_6.2.1
Digital supply voltage	V_{IO}	3.0	–	5.5	V	–	P_6.2.2
Thermal parameters							
Junction temperature	T_j	-40	–	150	°C	1)	P_6.2.3

1) Not subject to production test, specified by design.

Note: Within the functional range, the IC operates as described in the circuit description. The electrical characteristics are specified within the conditions given in the related electrical characteristics table.

5.3 Thermal resistance

Note: This thermal data was generated in accordance with JEDEC JESD51 standards. For more information, please visit www.jedec.org.

Table 5 Thermal resistance¹⁾

Parameter	Symbol	Values			Unit	Note or Test Condition	Number
		Min.	Typ.	Max.			
Thermal resistances							
Junction to ambient	R_{thJA}	–	130	–	K/W	2)	P_6.3.1
Thermal shutdown (junction temperature)							
Thermal shutdown temperature	T_{JSD}	150	175	200	°C	–	P_6.3.2
Thermal shutdown hyst.	ΔT	–	10	–	K	–	P_6.3.3

1) Not subject to production test, specified by design.

2) The R_{thJA} value specified is according to Jedec JESD51-2,-7 at natural convection on FR4 2s2p board; The product (TLE6251D) was simulated on a 76.2 x 114.3 x 1.5 mm board with 2 inner copper layers (2 x 70µm Cu, 2 x 35 µm Cu).

Electrical characteristics

6 Electrical characteristics

6.1 Functional device characteristics

Table 6 Electrical characteristics

4.5 V < V_{CC} < 5.5 V; 3.0 V < V_{IO} < 5.5 V; $R_L = 60 \Omega$; $-40^\circ\text{C} < T_j < 150^\circ\text{C}$; all voltages with respect to ground; positive current flowing into pin; unless otherwise specified.

Parameter	Symbol	Values			Unit	Note or Test Condition	Number
		Min.	Typ.	Max.			
Current consumption							
Current consumption at V_{CC} normal-operating mode	I_{CC}	–	2	6	mA	Recessive state, $V_{TXD} = V_{IO}$, STB = “low”;	P_7.1.1
Current consumption at V_{CC} normal-operating mode	I_{CC}	–	35	60	mA	Dominant state, $V_{TXD} = 0\text{ V}$. STB = “low”;	P_7.1.2
Current consumption at V_{IO} - normal-operating mode	I_{VIO}	–	–	1	mA	STB = “low”;	P_7.1.3
Current consumption at V_{CC} stand-by mode	$I_{VCC(STB)}$	–	–	5	μA	$V_{TXD} = V_{IO}$, $V_{CC} = 5\text{ V}$;	P_7.1.4
Current consumption at V_{IO} stand-by mode	$I_{VIO(STB)}$	–	–	25	μA	$V_{IO} = 5\text{ V}$, $V_{TXD} = V_{IO}$;	P_7.1.5
Current consumption at V_{IO} stand-by mode	$I_{VIO(STB)}$	–	15	21	μA	$V_{IO} = 5\text{ V}$, $V_{TXD} = V_{IO}$, $T_j = 40^\circ\text{C}$;	P_7.1.6
Supply resets							
V_{CC} undervoltage monitor	$V_{CC(UV)}$	3.8	4.0	4.3	V	Rising edge;	P_7.1.7
V_{CC} undervoltage monitor hysteresis	$V_{CC(UV,H)}$	–	150	–	mV	¹⁾	P_7.1.8
V_{IO} undervoltage monitor	$V_{IO(UV)}$	1.2	2.0	3.0	V	Rising edge;	P_7.1.9
V_{IO} undervoltage monitor hysteresis	$V_{CC(UV,H)}$	–	200	–	mV	¹⁾	P_7.1.10
V_{CC} and V_{IO} undervoltage delay time	$t_{\text{Delay(UV)}}$	–	–	50	μs	¹⁾ (see Figure 7);	P_7.1.11
Receiver output: RxD							
“High” level output current	$I_{RD,H}$	–	-4	-2	mA	$V_{\text{RxD}} = V_{IO} - 0,4\text{ V}$, $V_{\text{DIFF}} < 0.5\text{ V}$;	P_7.1.13
“Low” level output current	$I_{RD,L}$	2	4	–	mA	$V_{\text{RxD}} = 0.4\text{ V}$, $V_{\text{DIFF}} > 0.9\text{ V}$;	P_7.1.14

Electrical characteristics

Table 6 Electrical characteristics (cont'd)

4.5 V < V_{CC} < 5.5 V; 3.0 V < V_{IO} < 5.5 V; $R_L = 60 \Omega$; $-40^\circ\text{C} < T_j < 150^\circ\text{C}$; all voltages with respect to ground; positive current flowing into pin; unless otherwise specified.

Parameter	Symbol	Values			Unit	Note or Test Condition	Number
		Min.	Typ.	Max.			
Transmission input: TxD							
“High” level input voltage threshold	$V_{TD,H}$	–	$0.5 \times V_{IO}$	$0.7 \times V_{IO}$	V	Recessive state;	P_7.1.15
“Low” level input voltage threshold	$V_{TD,L}$	$0.3 \times V_{IO}$	$0.4 \times V_{IO}$	–	V	Dominant state;	P_7.1.16
TxD pull-up resistance	R_{TD}	10	25	50	k Ω	–	P_7.1.18
TxD input hysteresis	$V_{HYS(TxD)}$	–	800	–	mV	¹⁾	P_7.1.19
TxD permanent dominant disable time	t_{TxD}	4.5	–	16	ms	–	P_7.1.20
Stand-by input: STB							
“High” level input voltage threshold	$V_{STB,H}$	–	$0.5 \times V_{IO}$	$0.7 \times V_{IO}$	V	Stand-by mode;	P_7.1.21
“Low” level input voltage threshold	$V_{STB,L}$	$0.3 \times V_{IO}$	$0.4 \times V_{IO}$	–	V	Normal-operating mode;	P_7.1.22
STB pull-up resistance	R_{STB}	10	25	50	k Ω	–	P_7.1.24
STB input hysteresis	$V_{HYS(STB)}$	–	200	–	mV	¹⁾	P_7.1.25
Bus receiver							
Differential receiver threshold dominant	V_{DIFF_D}	–	0.75	0.9	V	Normal-operating mode;	P_7.1.26
Differential receiver threshold recessive	V_{DIFF_R}	0.5	0.65	–	V	Normal-operating mode;	P_7.1.27
Differential receiver threshold dominant	$V_{DIFF_D_STB}$	–	0.8	1.15	V	Stand-by mode;	P_7.1.28
Differential receiver threshold recessive	$V_{DIFF_R_STB}$	0.4	0.7	–	V	Stand-by mode;	P_7.1.29
Common mode range	CMR	-12	–	12	V	$V_{CC} = 5 \text{ V}$;	P_7.1.30
Differential receiver hysteresis	$V_{diff,hys}$	–	100	–	mV	¹⁾ Normal-operating mode;	P_7.1.31
CANH, CANL input resistance	R_i	10	20	30	k Ω	Recessive state;	P_7.1.32
Differential input resistance	R_{diff}	20	40	60	k Ω	Recessive state;	P_7.1.33
Input resistance deviation between CANH and CANL	ΔR_i	- 3	–	3	%	¹⁾ Recessive state;	P_7.1.34
Input capacitance CANH, CANL versus GND	C_{In}	–	20	40	pF	¹⁾ $V_{TXD} = V_{IO}$;	P_7.1.35
Differential input capacitance	C_{InDiff}	–	10	20	pF	¹⁾ $V_{TXD} = V_{IO}$;	P_7.1.36

Electrical characteristics

Table 6 Electrical characteristics (cont'd)

4.5 V < V_{CC} < 5.5 V; 3.0 V < V_{IO} < 5.5 V; $R_L = 60 \Omega$; $-40^\circ\text{C} < T_j < 150^\circ\text{C}$; all voltages with respect to ground; positive current flowing into pin; unless otherwise specified.

Parameter	Symbol	Values			Unit	Note or Test Condition	Number
		Min.	Typ.	Max.			
Bus transmitter							
CANL/CANH recessive output voltage	$V_{CANL/H}$	2.0	2.5	3.0	V	No load, $V_{TXD} = V_{IO}$, Normal-operating mode;	P_7.1.37
CANH, CANL recessive output voltage difference	V_{diff}	-500	-	50	mV	No load, $V_{TXD} = V_{IO}$, Normal-operating mode;	P_7.1.38
CANH, CANL recessive output voltage difference	V_{diff}	-0.1	-	0.1	V	No load, Stand-by mode;	P_7.1.39
CANL dominant output voltage	V_{CANL}	0.5	-	2.25	V	$V_{TXD} = 0\text{ V}$, $50 \Omega < R_L < 65 \Omega$ Normal-operating mode;	P_7.1.40
CANH dominant output voltage	V_{CANH}	2.75	-	4.5	V	$V_{TXD} = 0\text{ V}$, $50 \Omega < R_L < 65 \Omega$ Normal-operating mode;	P_7.1.41
CANH, CANL dominant output voltage difference $V_{diff} = V_{CANH} - V_{CANL}$	V_{diff}	1.5	-	3.0	V	$4.75\text{ V} < V_{CC} < 5.25\text{ V}$, $V_{TXD} = 0\text{ V}$, $50 \Omega < R_L < 65 \Omega$ Normal-operating mode;	P_7.1.42
Driver symmetry $V_{SYM} = V_{CANH} + V_{CANL}$	V_{SYM}	4.5	5	5.5	V	$V_{TXD} = 0\text{ V}$, $V_{CC} = 5\text{ V}$, Normal-operating mode;	P_7.1.43
CANL short-circuit current	I_{CANLsc}	40	75	100	mA	$V_{TXD} = 0\text{ V}$, $V_{CC} = 5\text{ V}$, $t < t_{TXD}$, $V_{CANLshort} = 18\text{ V}$;	P_7.1.44
CANH short-circuit current	I_{CANHsc}	-100	-75	-40	mA	$V_{TXD} = 0\text{ V}$, $V_{CC} = 5\text{ V}$, $t < t_{TXD}$, $V_{CANHshort} = 0\text{ V}$;	P_7.1.45
Leakage current, CANH	$I_{CANH,lk}$	-5	-	5	μA	$V_{CC} = 0\text{ V}$, $V_{CANH} = V_{CANL}$, $0\text{ V} < V_{CANH} < 5\text{ V}$;	P_7.1.46
Leakage current, CANL	$I_{CANL,lk}$	-5	-	5	μA	$V_{CC} = 0\text{ V}$, $V_{CANH} = V_{CANL}$, $0\text{ V} < V_{CANL} < 5\text{ V}$;	P_7.1.47

Dynamic CAN-transceiver characteristics

Electrical characteristics

Table 6 Electrical characteristics (cont'd)

4.5 V < V_{CC} < 5.5 V; 3.0 V < V_{IO} < 5.5 V; R_L = 60 Ω; -40°C < T_j < 150°C; all voltages with respect to ground; positive current flowing into pin; unless otherwise specified.

Parameter	Symbol	Values			Unit	Note or Test Condition	Number
		Min.	Typ.	Max.			
Propagation delay TxD-to-RxD “low”; (“recessive to dominant)	t _{d(L),TR}	30	180	255	ns	C _L = 100 pF, V _{CC} = 5 V, C _{RxD} = 15 pF;	P_7.1.50
Propagation delay TxD-to-RxD “high”; (dominant to recessive)	t _{d(H),TR}	30	200	255	ns	C _L = 100 pF, V _{CC} = 5 V, C _{RxD} = 15 pF;	P_7.1.51
Propagation delay TxD “low” to bus dominant	t _{d(L),T}	–	100	–	ns	¹⁾ C _L = 100 pF, V _{CC} = 5 V, C _{RxD} = 15 pF;	P_7.1.52
Propagation delay TxD “high” to bus recessive	t _{d(H),T}	–	90	–	ns	¹⁾ C _L = 100 pF, V _{CC} = 5 V, C _{RxD} = 15 pF;	P_7.1.53
Propagation delay bus dominant to RxD “low”	t _{d(L),R}	–	80	–	ns	¹⁾ C _L = 100 pF, V _{CC} = 5 V, C _{RxD} = 15 pF;	P_7.1.54
Propagation delay bus recessive to RxD “high”	t _{d(H),R}	–	110	–	ns	¹⁾ C _L = 100 pF; V _{CC} = 5 V; C _{RxD} = 15 pF;	P_7.1.55
Bus wake-up time	t _{WU}	0.5	3	5	μs	see Figure 5	P_7.1.57
Delay time for mode change	t _{Mode}	–	–	10	μs	²⁾	P_7.1.58

- 1) Not subject to production test, specified by design.
- 2) Delay time only tested for the mode change from stand-by mode to normal-operating mode. The delay time normal-operating mode to stand-by mode is not subject to production test and specified by design.

6.2 Diagrams

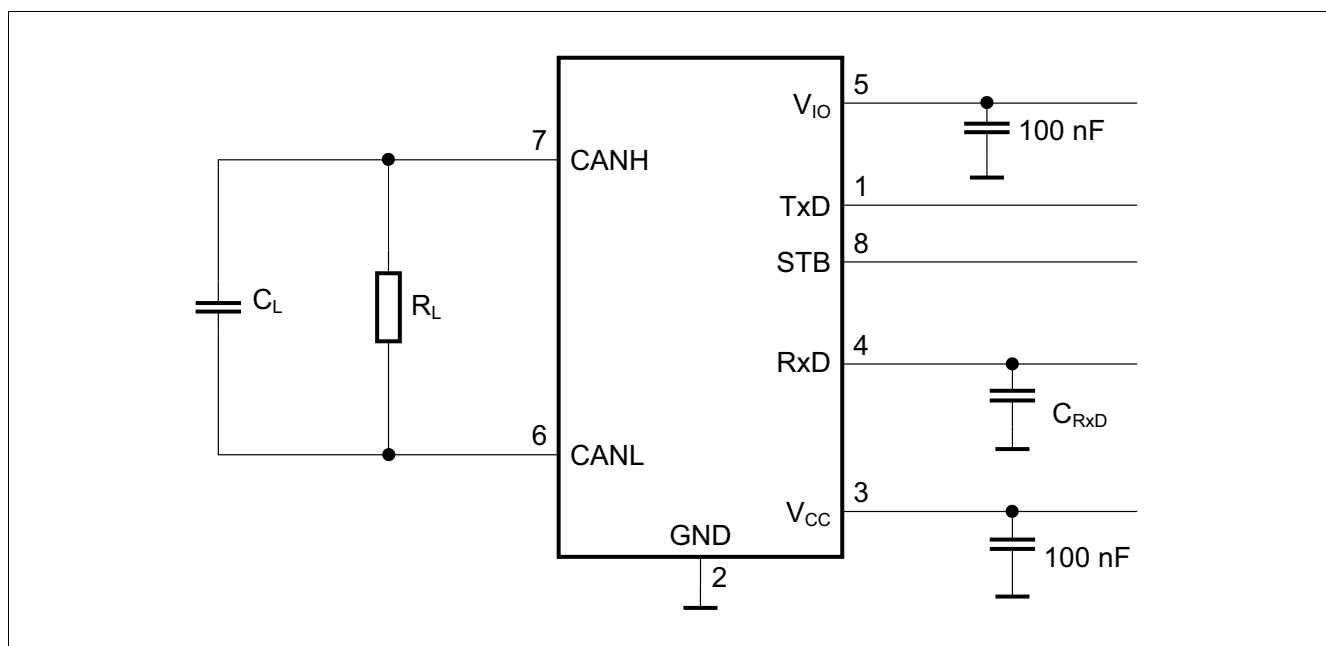

Figure 9 Simplified test circuit

Electrical characteristics

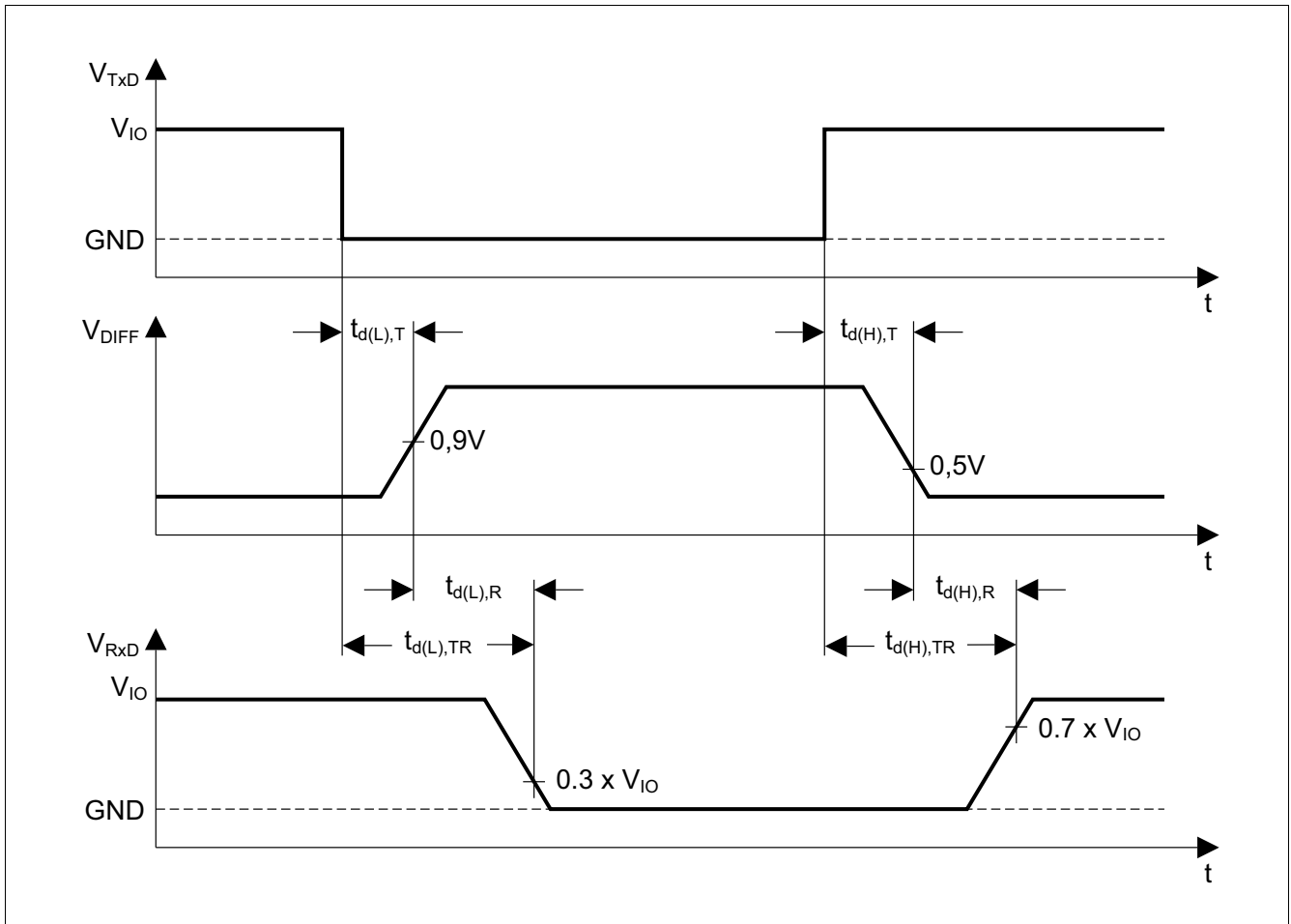

Figure 10 Timing diagrams for dynamic characteristics

Application information

7 Application information

7.1 ESD immunity according to IEC61000-4-2

Tests for ESD immunity according to IEC61000-4-2, “GUN test” (150 pF, 330 Ω), have been performed. The results and test conditions are available in a separate test report.

Table 7 ESD immunity according to IEC61000-4-2

Test performed	Result	Unit	Remarks
Electrostatic discharge voltage at CANH and CANL pins against GND	$\geq +9$	kV	¹⁾ Positive pulse
Electrostatic discharge voltage at pin CANH and CANL pins against GND	≤ -9	kV	¹⁾ Negative pulse

- 1) ESD susceptibility “ESD GUN” according to GIFT / ICT paper: “EMC Evaluation of CAN Transceivers, version 03/02/ IEC TS 62228“, section 4.3. (DIN EN61000-4-2).
Tested by external test facility (IBEE Zwickau, EMC test report no.: 08-04-12).

Application information

7.2 Application example

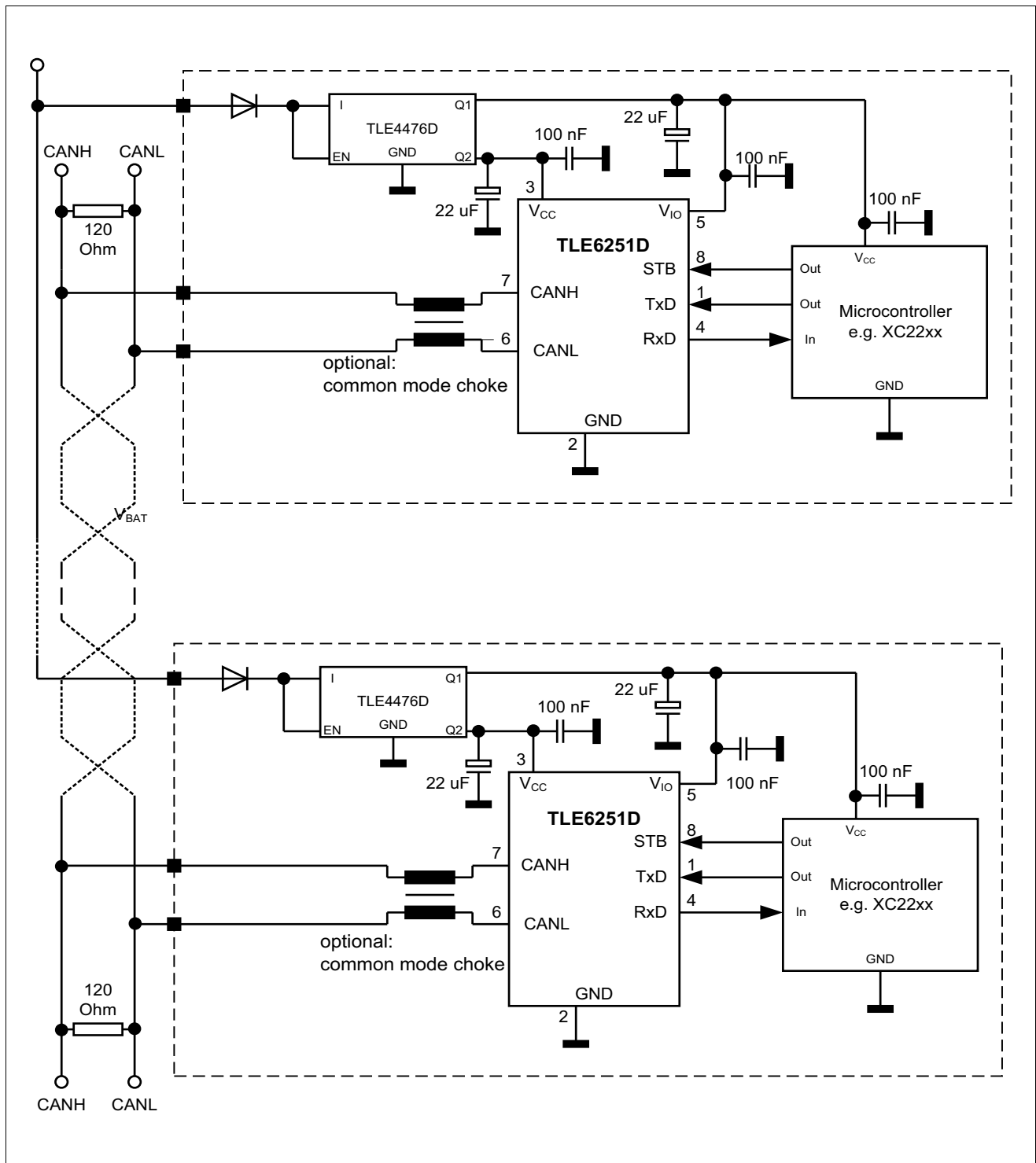

Figure 11 Application circuit

7.3 Further application information

- Please contact us for information regarding the pin FMEA.
- For further information you may visit: <http://www.infineon.com/automotive-transceivers>.

8 Package outlines

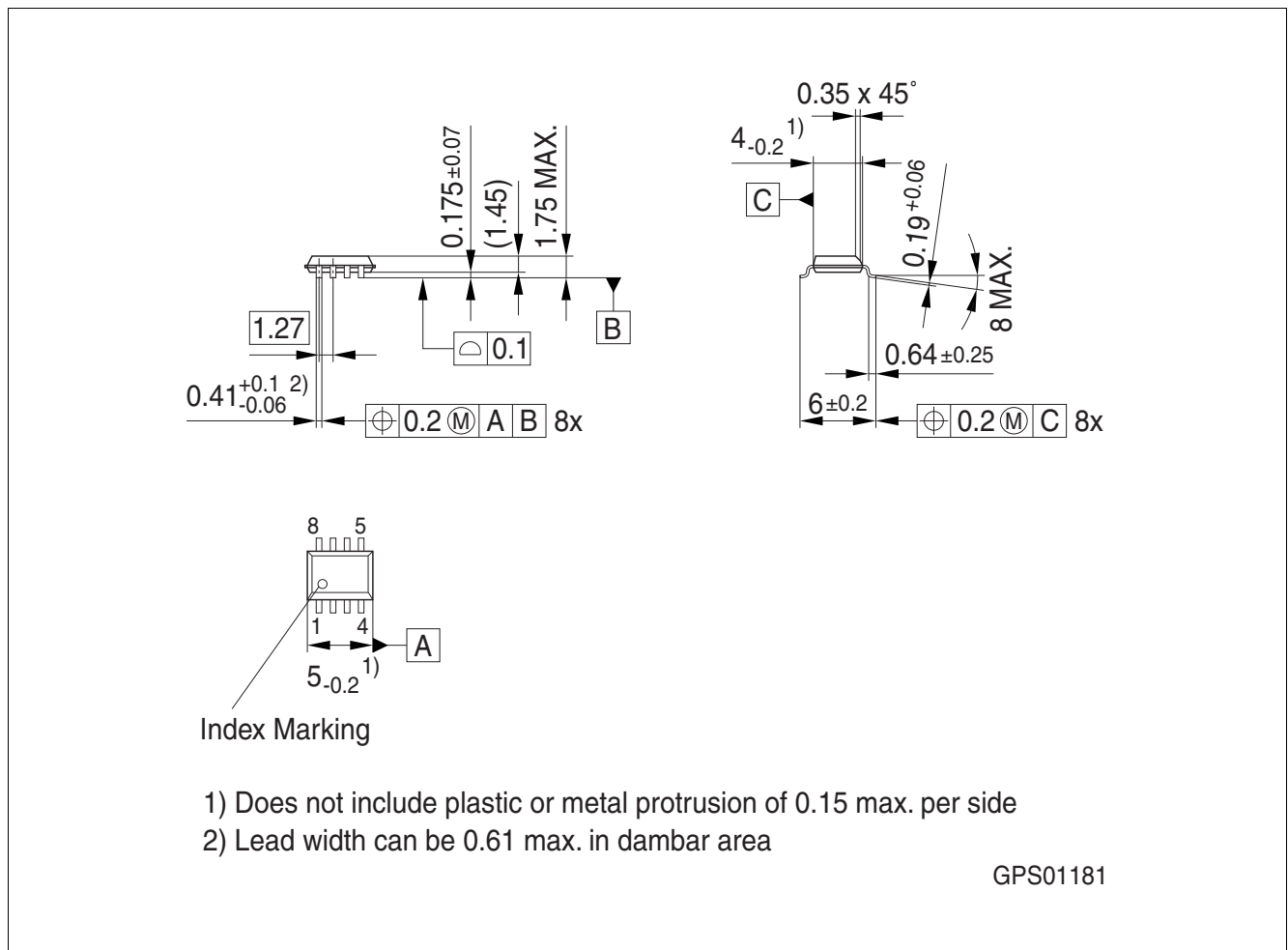

Figure 12 PG-DSO-8 (Plastic Dual Small Outline)¹⁾

Green Product (RoHS compliant)

To meet the world-wide customer requirements for environmentally friendly products and to be compliant with government regulations the device is available as a green product. Green products are RoHS-Compliant (i.e. Pb-free finish on leads and suitable for Pb-free soldering according to IPC/JEDEC J-STD-020).

Further information on packages

<https://www.infineon.com/packages>

1) Dimensions in mm

Revision history

9 Revision history

Revision	Date	Changes
1.11	2019-07-17	Editorial changes.
1.1	2016-06-06	Datasheet updated to new style template. Editorial changes. <ul style="list-style-type: none">• Chapter 4.6 updated: Passage, entering stand-by mode removed.• Former Chapter 5.6 removed: “Mode Changes during CAN Bus Failures”, Former Figure 10 in Chapter 5.7 removed.• Figure 11 “Application circuit” on Page 23 termination resistors added.
1.0	2012-07-27	Datasheet created.

Trademarks

All referenced product or service names and trademarks are the property of their respective owners.

Edition 2019-07-17

Published by

Infineon Technologies AG

81726 Munich, Germany

© 2019 Infineon Technologies AG.

All Rights Reserved.

Do you have a question about any aspect of this document?

Email: erratum@infineon.com

Document reference

Z8F53155353

IMPORTANT NOTICE

The information given in this document shall in no event be regarded as a guarantee of conditions or characteristics ("Beschaffenhheitsgarantie").

With respect to any examples, hints or any typical values stated herein and/or any information regarding the application of the product, Infineon Technologies hereby disclaims any and all warranties and liabilities of any kind, including without limitation warranties of non-infringement of intellectual property rights of any third party.

In addition, any information given in this document is subject to customer's compliance with its obligations stated in this document and any applicable legal requirements, norms and standards concerning customer's products and any use of the product of Infineon Technologies in customer's applications.

The data contained in this document is exclusively intended for technically trained staff. It is the responsibility of customer's technical departments to evaluate the suitability of the product for the intended application and the completeness of the product information given in this document with respect to such application.

For further information on technology, delivery terms and conditions and prices, please contact the nearest Infineon Technologies Office (www.infineon.com).

WARNINGS

Due to technical requirements products may contain dangerous substances. For information on the types in question please contact your nearest Infineon Technologies office.

Except as otherwise explicitly approved by Infineon Technologies in a written document signed by authorized representatives of Infineon Technologies, Infineon Technologies' products may not be used in any applications where a failure of the product or any consequences of the use thereof can reasonably be expected to result in personal injury.

Компания «Океан Электроники» предлагает заключение долгосрочных отношений при поставках импортных электронных компонентов на взаимовыгодных условиях!

Наши преимущества:

- Поставка оригинальных импортных электронных компонентов напрямую с производств Америки, Европы и Азии, а так же с крупнейших складов мира;
- Широкая линейка поставок активных и пассивных импортных электронных компонентов (более 30 млн. наименований);
- Поставка сложных, дефицитных, либо снятых с производства позиций;
- Оперативные сроки поставки под заказ (от 5 рабочих дней);
- Экспресс доставка в любую точку России;
- Помощь Конструкторского Отдела и консультации квалифицированных инженеров;
- Техническая поддержка проекта, помощь в подборе аналогов, поставка прототипов;
- Поставка электронных компонентов под контролем ВП;
- Система менеджмента качества сертифицирована по Международному стандарту ISO 9001;
- При необходимости вся продукция военного и аэрокосмического назначения проходит испытания и сертификацию в лаборатории (по согласованию с заказчиком);
- Поставка специализированных компонентов военного и аэрокосмического уровня качества (Xilinx, Altera, Analog Devices, Intersil, Interpoint, Microsemi, Actel, Aeroflex, Peregrine, VPT, Syfer, Eurofarad, Texas Instruments, MS Kennedy, Miteq, Cobham, E2V, MA-COM, Hittite, Mini-Circuits, General Dynamics и др.);

Компания «Океан Электроники» является официальным дистрибьютором и эксклюзивным представителем в России одного из крупнейших производителей разъемов военного и аэрокосмического назначения «**JONHON**», а так же официальным дистрибьютором и эксклюзивным представителем в России производителя высокотехнологичных и надежных решений для передачи СВЧ сигналов «**FORSTAR**».



JONHON

«**JONHON**» (основан в 1970 г.)

Разъемы специального, военного и аэрокосмического назначения:

(Применяются в военной, авиационной, аэрокосмической, морской, железнодорожной, горно- и нефтедобывающей отраслях промышленности)

«**FORSTAR**» (основан в 1998 г.)

ВЧ соединители, коаксиальные кабели,
кабельные сборки и микроволновые компоненты:

(Применяются в телекоммуникациях гражданского и специального назначения, в средствах связи, РЛС, а так же военной, авиационной и аэрокосмической отраслях промышленности).



Телефон: 8 (812) 309-75-97 (многоканальный)

Факс: 8 (812) 320-03-32

Электронная почта: ocean@oceanchips.ru

Web: <http://oceanchips.ru/>

Адрес: 198099, г. Санкт-Петербург, ул. Калинина, д. 2, корп. 4, лит. А