

## Overvoltage protected AC switch

Datasheet - production data

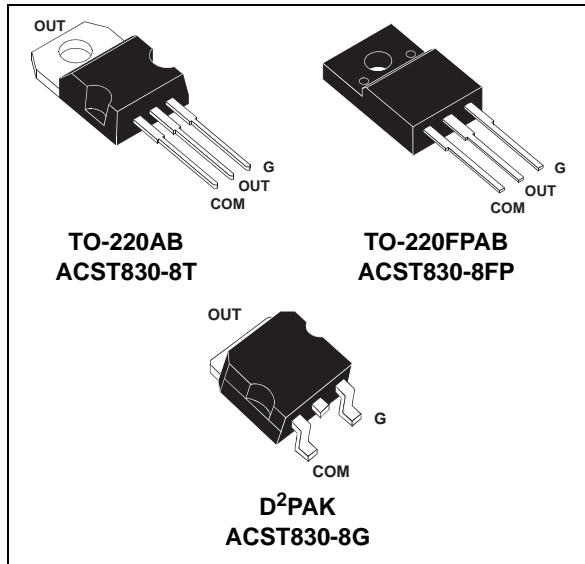
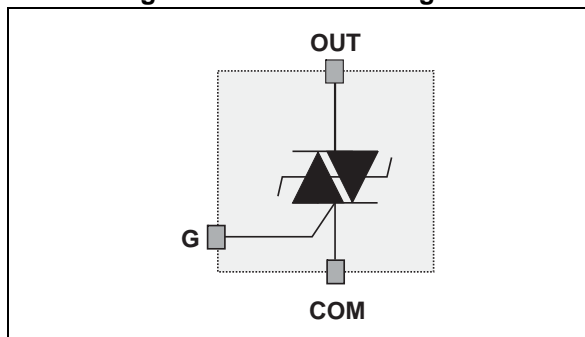

Figure 1. Functional diagram



### Features

- Triac with overvoltage protection
- High noise immunity: static  $dV/dt > 2000 \text{ V}/\mu\text{s}$
- TO-220FPAB insulated package:
  - complies with UL standards (file ref: E81734)
  - insulation voltage:  $2000 \text{ V}_{\text{RMS}}$

### Benefits

- Enables equipment to meet IEC 61000-4-5

- High off-state reliability with planar technology
- Needs no external overvoltage protection
- Reduces the power passive component count
- High immunity against fast transients described in IEC 61000-4-4 standards

### Applications

- AC mains static switching in appliance and industrial control systems
- Drive of medium power AC loads such as:
  - Universal motor of washing machine drum
  - Compressor for fridge or air conditioner

### Description

The ACST8 series belongs to the ACS/ACST power switch family built around A.S.D. (application specific discrete) technology. This high performance device is suited to home appliances or industrial systems and drives an induction motor up to 8 A.

This ACST8 device embeds a Triac structure with a high voltage clamping device to absorb the inductive turn off energy and withstand line transients such as those described in the IEC 61000-4-5 standards.

ACST8 shows a high noise immunity complying with IEC standards such as IEC 61000-4-4 (fast transient burst test).

Table 1. Device summary

Symbol	Value	Unit
$I_{\text{T(RMS)}}$	8	A
$V_{\text{DRM}}/V_{\text{RRM}}$	800	V
$I_{\text{GT}}$	30	mA

# 1 Characteristics

**Table 2. Absolute ratings (limiting values)**

Symbol	Parameter		Value	Unit	
$I_{T(RMS)}$	On-state rms current (full sine wave)	TO-220FPAB	$T_{case} = 91\text{ °C}$	8	A
		TO-220AB / D <sup>2</sup> PAK	$T_{case} = 105\text{ °C}$		
		D <sup>2</sup> PAK with 1 cm <sup>2</sup> Cu	$T_{amb} = 43\text{ °C}$	2	A
$I_{TSM}$	Non repetitive surge peak on-state current $T_j$ initial = 25 °C, full cycle sine wave	F = 50 Hz	$t_p = 20\text{ ms}$	80	A
		F = 60 Hz	$t_p = 16.7\text{ ms}$	84	A
$I^2t$	Thermal constraint for fuse selection		$t_p = 10\text{ ms}$	42	A <sup>2</sup> s
dI/dt	Critical rate of rise on-state current $I_G = 2 \times I_{GT}$ , ( $t_r \leq 100\text{ ns}$ )	F = 120 Hz	$T_j = 125\text{ °C}$	100	A/ $\mu$ s
$V_{PP}^{(1)}$	Non repetitive line peak pulse voltage		$T_j = 25\text{ °C}$	2	kV
$P_{G(AV)}$	Average gate power dissipation		$T_j = 125\text{ °C}$	0.1	W
$P_{GM}$	Peak gate power dissipation ( $t_p = 20\text{ ms}$ )		$T_j = 125\text{ °C}$	10	W
$I_{GM}$	Peak gate current ( $t_p = 20\text{ ms}$ )		$T_j = 125\text{ °C}$	1.6	A
$T_{stg}$	Storage temperature range			- 40 to + 150	°C
$T_j$	Operating junction temperature range			- 40 to + 125	°C
$T_l$	Maximum lead soldering temperature during 10 s			260	°C
$V_{INS(RMS)}$	Insulation RMS voltage (60 seconds)	TO-220FPAB		2000	V

1. According to test described in IEC 61000-4-5 standard and [Figure 17](#).

**Table 3. Electrical characteristics per switch**

Symbol	Test conditions	Quadrant	$T_j$		Value	Unit
$I_{GT}^{(1)}$	$V_{OUT} = 12\text{ V}$ , $R_L = 33\ \Omega$	I - II - III	25 °C	Max	30	mA
$V_{GT}$	$V_{OUT} = 12\text{ V}$ , $R_L = 33\ \Omega$	I - II - III	25 °C	Max	1.0	V
$V_{GD}$	$V_{OUT} = V_{DRM}$ , $R_L = 3.3\text{ k}\Omega$	I - II - III	125 °C	Min	0.2	V
$I_H^{(2)}$	$I_{OUT} = 500\text{ mA}$		25 °C	Max	30	mA
$I_L$	$I_G = 1.2 \times I_{GT}$	I - II - III	25 °C	Max	50	mA
$dV/dt^{(2)}$	$V_{OUT} = 67\% V_{DRM}$ , gate open		125 °C	Min	2000	V/ $\mu$ s
$(dI/dt)_C^{(2)}$	Without snubber		125 °C	Min	8	A/ms
$V_{CL}$	$I_{CL} = 0.1\text{ mA}$ , $t_p = 1\text{ ms}$		25 °C	Min	850	V

1. Minimum  $I_{GT}$  is guaranteed at 5% of  $I_{GT(Max)}$
2. For either positive or negative polarity of OUT pin with reference to COM pin

**Table 4. Static characteristics**

Symbol	Test conditions			Value	Unit
$V_{TM}$	$I_{TM} = 11.3 \text{ A}$ $t_p = 500 \mu\text{s}$	$T_j = 25 \text{ }^\circ\text{C}$	Max	1.5	V
$V_{TO}$	Threshold voltage	$T_j = 125 \text{ }^\circ\text{C}$	Max	0.9	V
$R_D$	Dynamic resistance	$T_j = 125 \text{ }^\circ\text{C}$	Max	50	m $\Omega$
$I_{DRM}$ $I_{RRM}$	$V_{OUT} = V_{DRM} / V_{RRM}$	$T_j = 25 \text{ }^\circ\text{C}$	Max	20	$\mu\text{A}$
		$T_j = 125 \text{ }^\circ\text{C}$		1	mA

**Table 5. Thermal resistances**

Symbol	Parameter		Value	Unit
$R_{th(j-a)}$	Junction to ambient	TO-220FPAB TO-220AB	60	$^\circ\text{C/W}$
	Junction to ambient (soldered on 1 cm <sup>2</sup> copper pad)	D <sup>2</sup> PAK	45	
$R_{th(j-c)}$	Junction to case (AC)	TO-220FPAB	3.6	
		TO-220AB, D <sup>2</sup> PAK	2	

**Figure 2. Maximum power dissipation versus on-state RMS current**

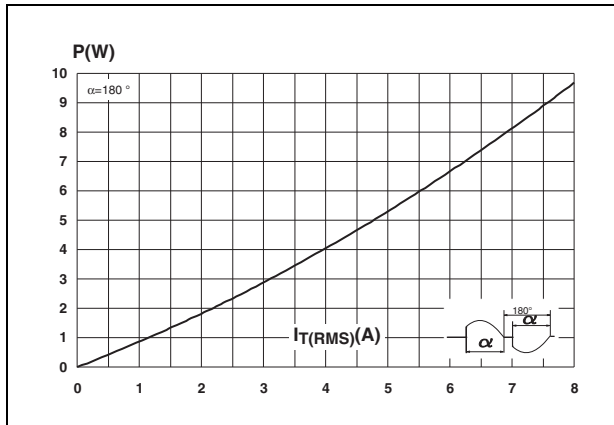

**Figure 3. On-state RMS current versus case temperature (full cycle)**

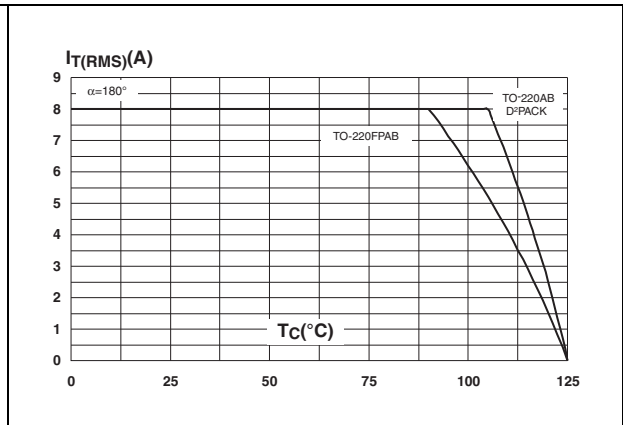

Figure 4. On-state RMS current versus ambient temperature (free air convection, full cycle)

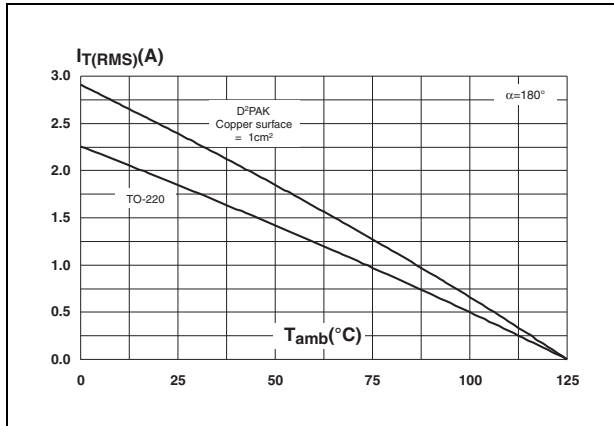

Figure 5. Relative variation of thermal impedance versus pulse duration

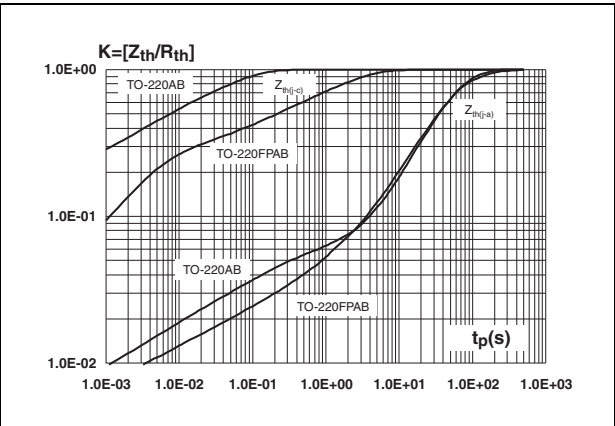

Figure 6. Relative variation of gate trigger current (IGT) and voltage (VGT) versus junction temperature

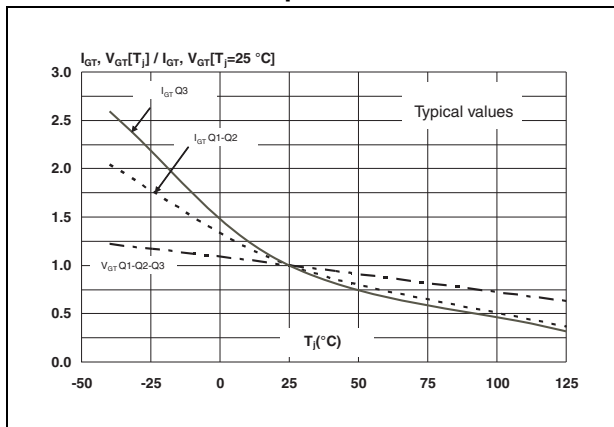

Figure 7. Relative variation of holding current (IH) and latching current (IL) versus junction temperature

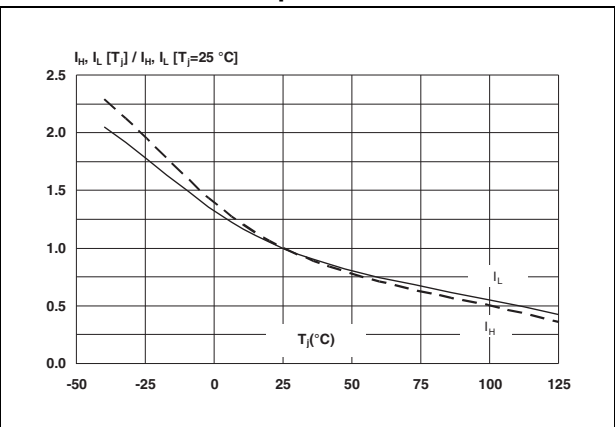

Figure 8. Surge peak on-state current versus number of cycles

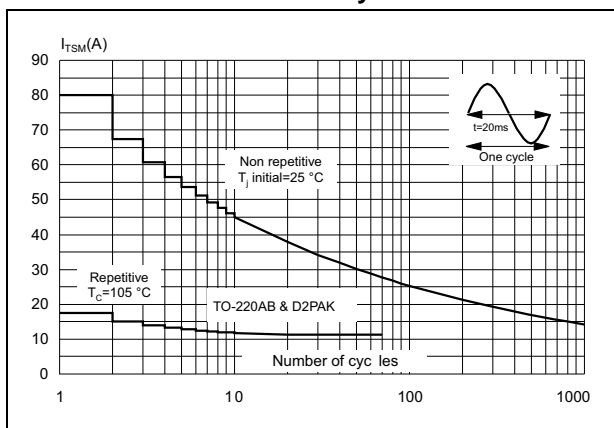

Figure 9. Non repetitive surge peak on-state current versus sinusoidal pulse width

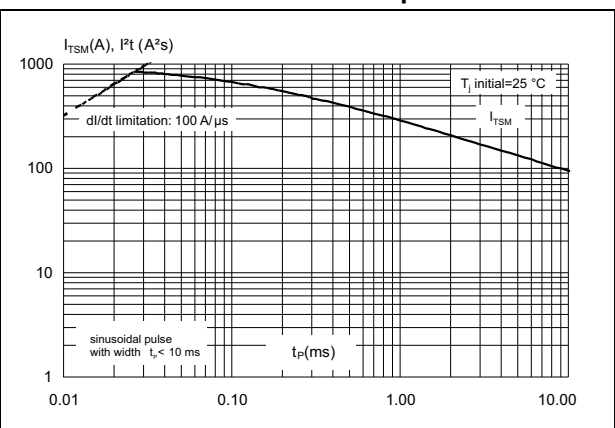

Figure 10. On-state characteristics (maximum values)

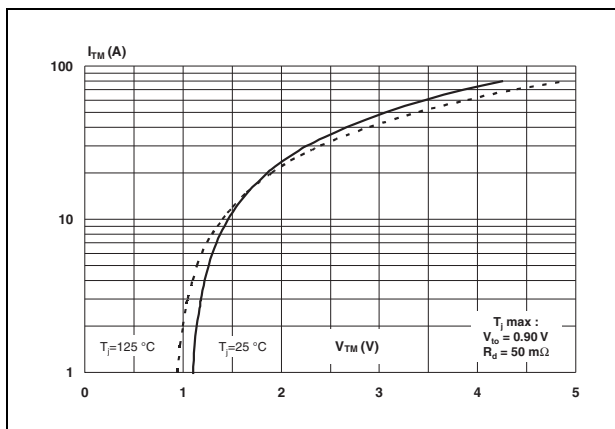

Figure 11. Relative variation of critical rate of decrease of main current  $(di/dt)_c$  versus junction temperature

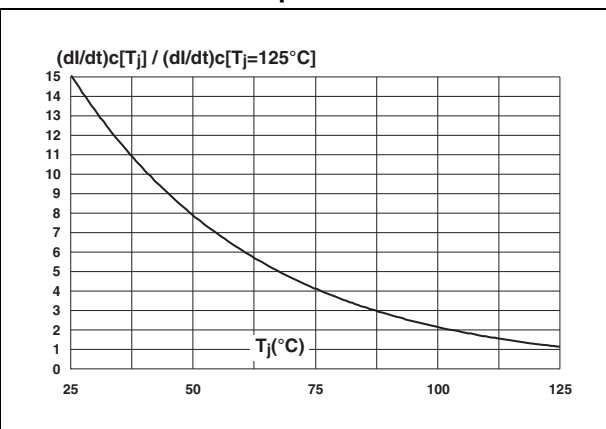

Figure 12. Relative variation of static dV/dt immunity versus junction temperature (gate open)

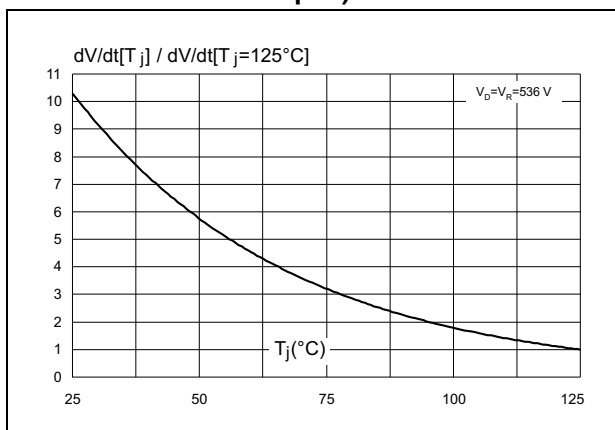

Figure 13. Relative variation of leakage current versus junction temperature

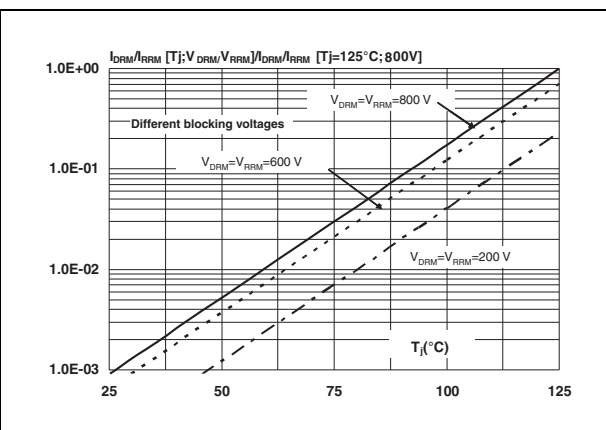

Figure 14. Relative variation of clamping voltage  $(V_{CL})$  versus junction temperature (minimum values)

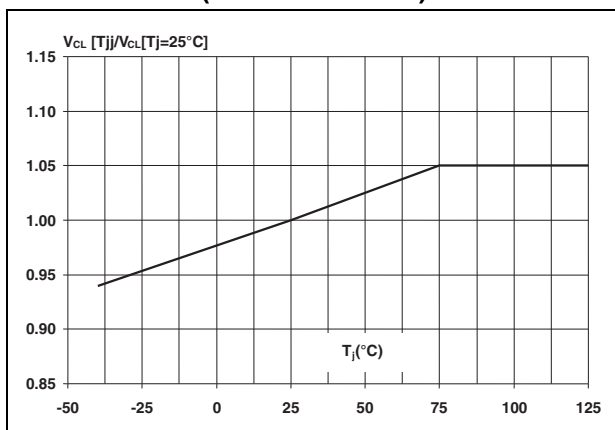
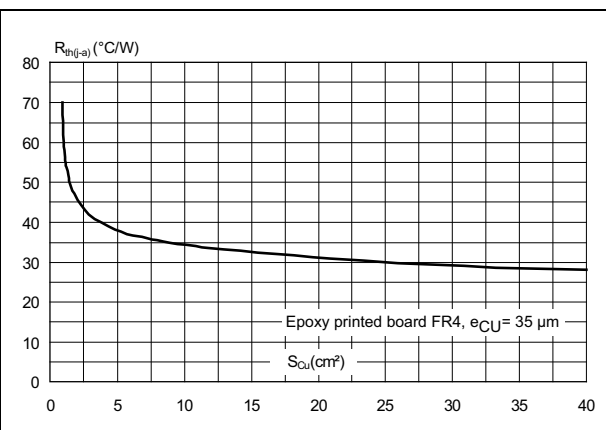

Figure 15. Thermal resistance junction to ambient versus copper surface under tab



## 2 Application information

### 2.1 Typical application description

The ACST8 device has been designed to control medium power load, such as AC motors in home appliances. Thanks to its thermal and turn off commutation performances, the ACST8 switch is able to drive an inductive load up to 8 A with no turn off additional snubber. It also provides high thermal performances in static and transient modes such as high torque operating conditions or inrush current of an AC motor.

Figure 16. AC induction motor control – typical diagram

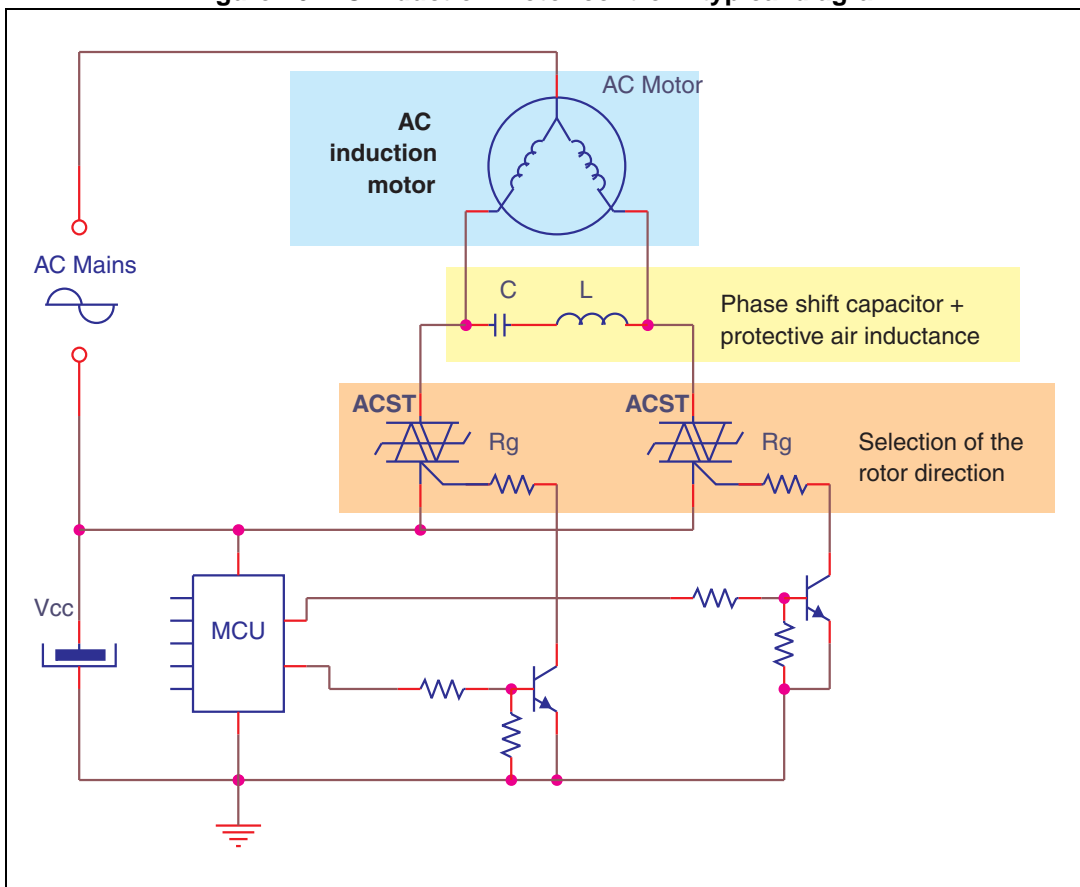

## 2.2 AC line transient voltage ruggedness

In comparison with standard Triacs, which are not robust against surge voltage, the ACST8 is self-protected against over-voltage, specified by the new parameter  $V_{CL}$ . The ACST8 switch can safely withstand AC line transient voltages either by clamping the low energy spikes, such as inductive spikes at switch off, or by switching to the on state (for less than 10 ms) to dissipate higher energy shocks through the load. This safety feature works even with high turn-on current ramp up.

The test circuit of [Figure 17](#) represents the ACST8 application, and is used to stress the ACST switch according to the IEC 61000-4-5 standard conditions. With the additional effect of the load which is limiting the current, the ACST switch withstands the voltage spikes up to 2 kV on top of the peak line voltage. The protection is based on an overvoltage crowbar technology. The ACST8 folds back safely to the on state as shown in [Figure 18](#). The ACST8 recovers its blocking voltage capability after the surge and the next zero current crossing. Such a non repetitive test can be done at least 10 times on each AC line voltage polarity.

**Figure 17. Overvoltage ruggedness test circuit for resistive and inductive loads for IEC 61000-4-5 standards**

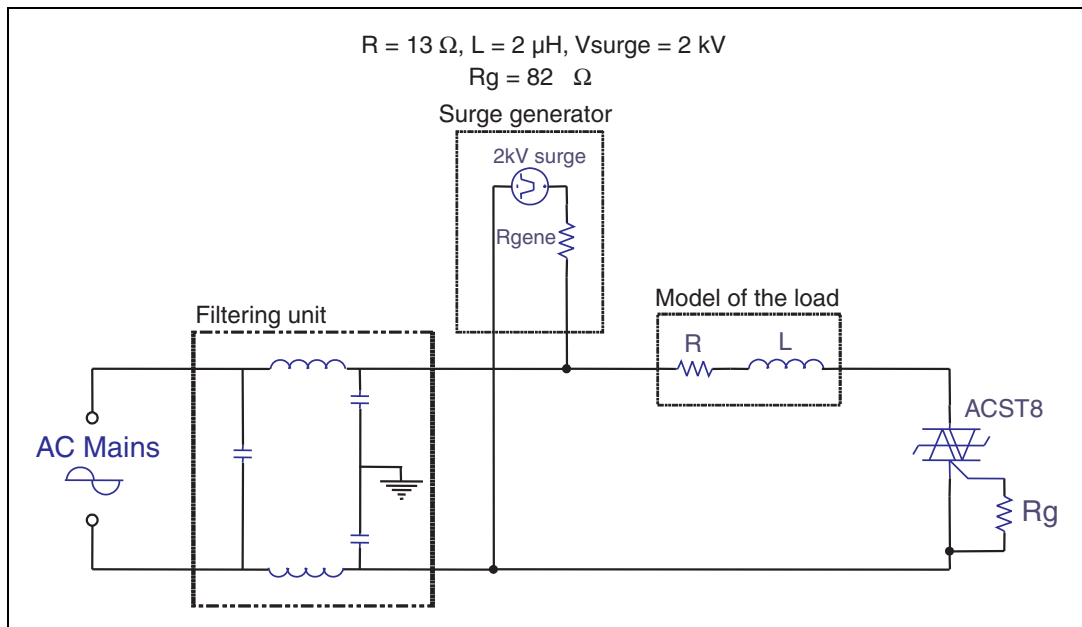
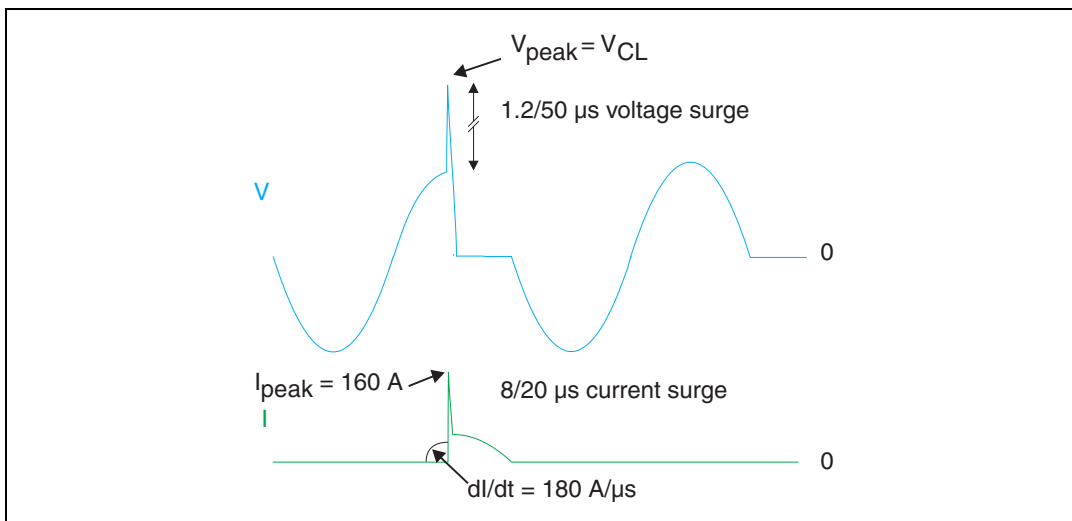
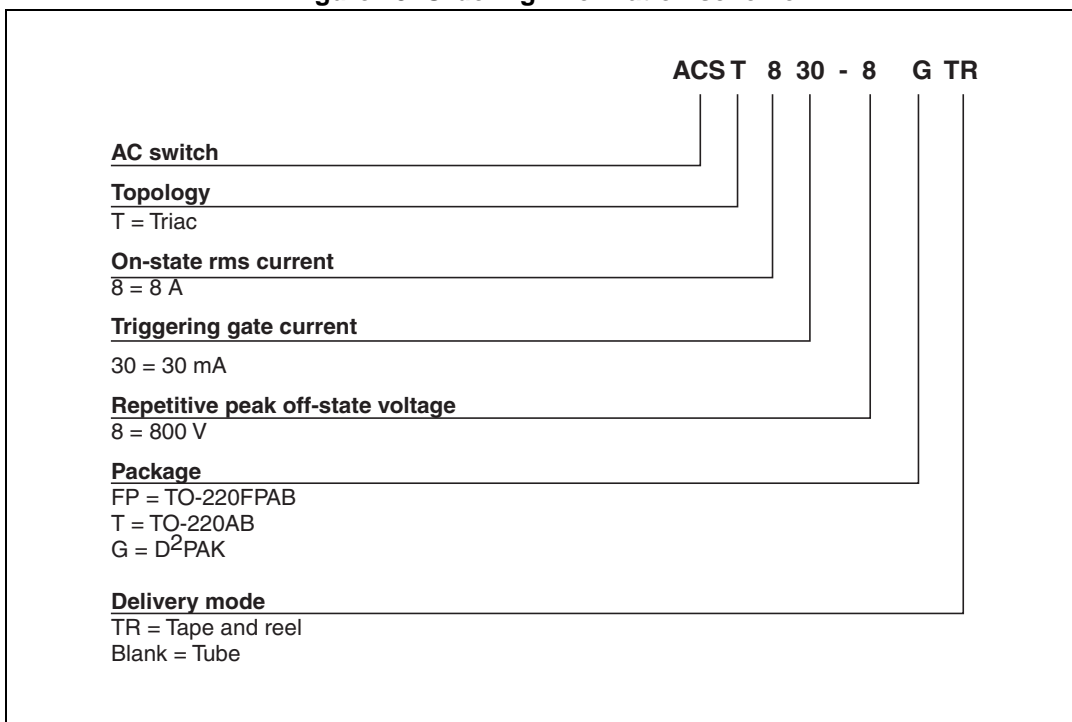

Figure 18. Typical current and voltage waveforms across the ACST8 during IEC 61000-4-5 standard test



### 3 Ordering information scheme

Figure 19. Ordering information scheme





## 4 Package information

- Epoxy meets UL94, V0
- Recommended torque: 0.4 to 0.6 N·m

In order to meet environmental requirements, ST offers these devices in different grades of ECOPACK<sup>®</sup> packages, depending on their level of environmental compliance. ECOPACK<sup>®</sup> specifications, grade definitions and product status are available at: [www.st.com](http://www.st.com). ECOPACK<sup>®</sup> is an ST trademark.

### 4.1 TO-220AB package information

Figure 20. TO-220AB package outline

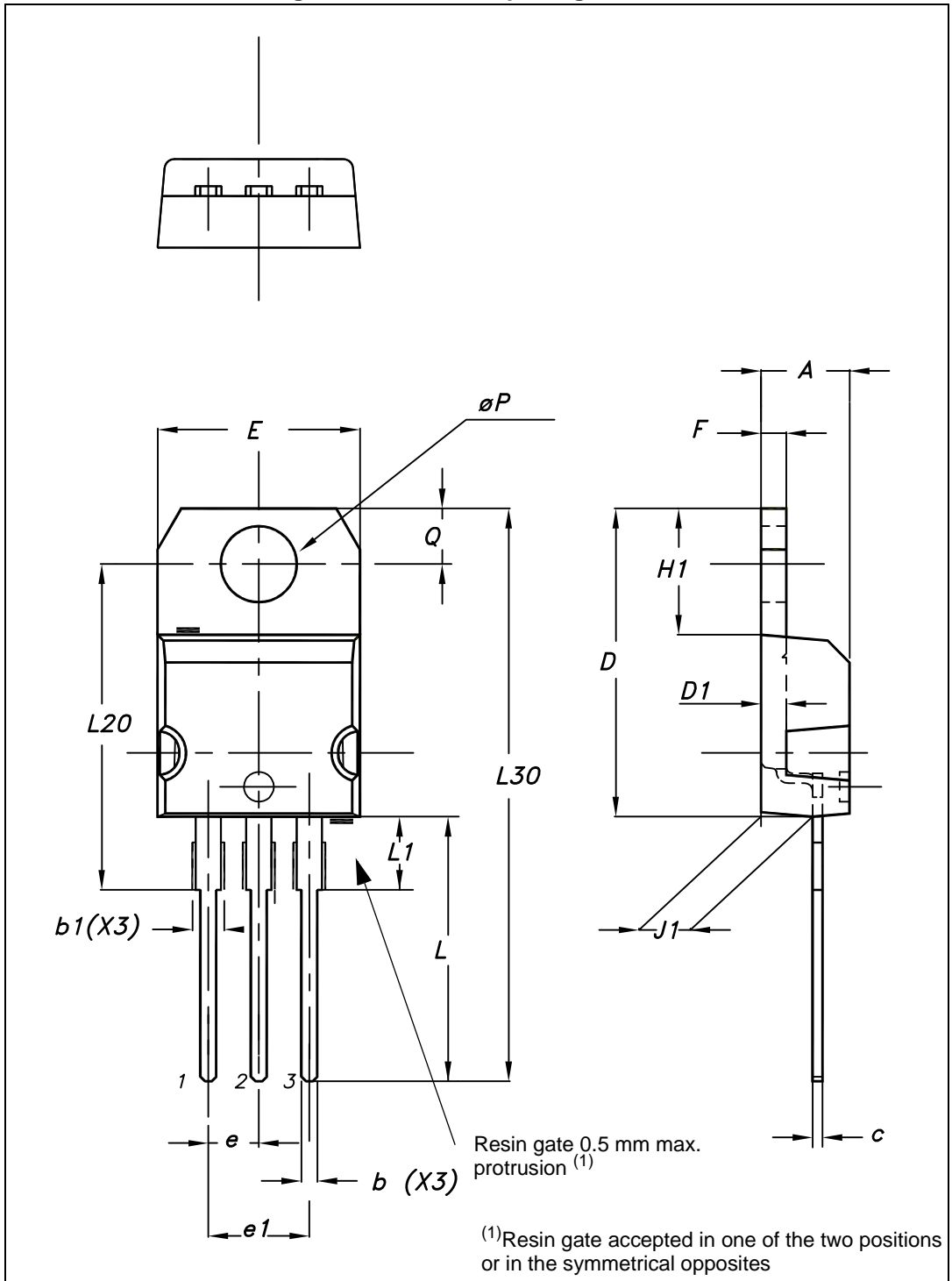

Table 6. TO-220AB package mechanical data

Ref.	Dimensions			
	Millimeters		Inches	
	Min.	Max.	Min.	Max.
A	4.4	4.6	0.1732	0.1811
b	0.61	0.88	0.024	0.0346
b1	1.14	1.55	0.0449	0.0610
c	0.48	0.7	0.0189	0.0276
D	15.25	15.75	0.6004	0.6201
D1	1.27 typ.		0.0500 typ.	
E	10	10.4	0.3937	0.4094
e	2.4	2.7	0.0945	0.1063
e1	4.95	5.15	0.1949	0.2028
F	1.23	1.32	0.0484	0.052
H1	6.2	6.6	0.2441	0.2598
J1	2.4	2.72	0.0945	0.1071
L	13	14	0.5118	0.5512
L1	3.5	3.93	0.1378	0.1547
L20	16.40 typ.		0.6457 typ.	
L30	28.90 typ.		1.1378 typ.	
θP	3.75	3.85	0.1476	0.1516
Q	2.65	2.95	0.1043	0.1161

### 4.2 TO-220FPAB package information

Figure 21. TO-220FPAB package outline

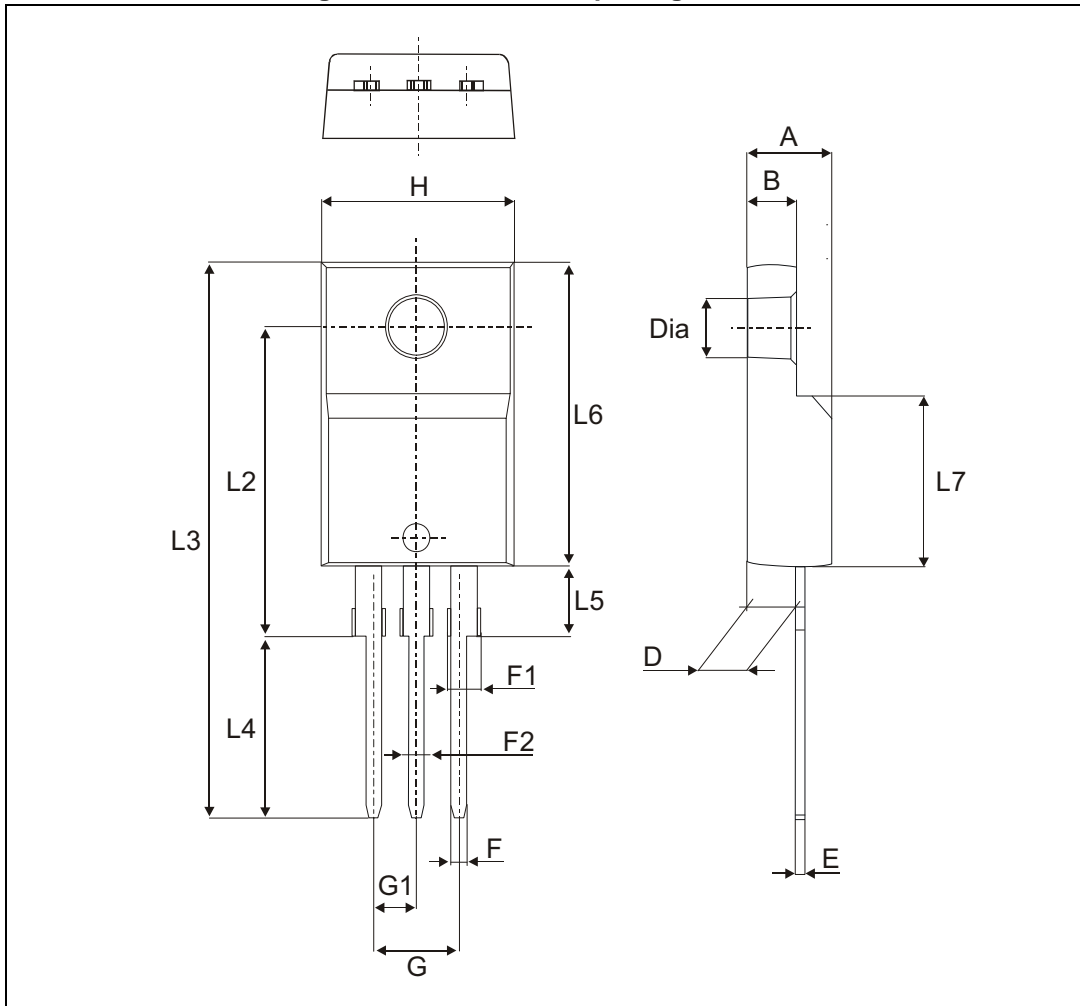

Table 7. TO-220FPAB package mechanical data

Ref.	Dimensions			
	Millimeters		Inches	
	Min.	Max.	Min.	Max.
A	4.40	4.60	0.1739	0.1818
B	2.50	2.70	0.0988	0.1067
D	2.50	2.750	0.0988	0.1087
E	0.45	0.70	0.0178	0.0277
F	0.75	1.0	0.0296	0.0395
F1	1.15	1.70	0.0455	0.0672
F2	1.15	1.70	0.0455	0.0672
G	4.95	5.20	0.1957	0.2055
G1	2.40	2.70	0.0949	0.1067
H	10.0	10.4	0.3953	0.4111
L2	16 Typ.		0.6324 Typ.	
L3	28.6	30.6	1.1304	1.2095
L4	9.8	10.6	0.3874	0.4190
L5	2.9	3.6	0.1146	0.1423
L6	15.9	16.4	0.6285	0.6482
L7	9.00	9.30	0.3557	0.3676
Diam.	3.00	3.20	0.1186	0.1265

### 4.3 D<sup>2</sup>PAK package information

Figure 22. D<sup>2</sup>PAK package outline

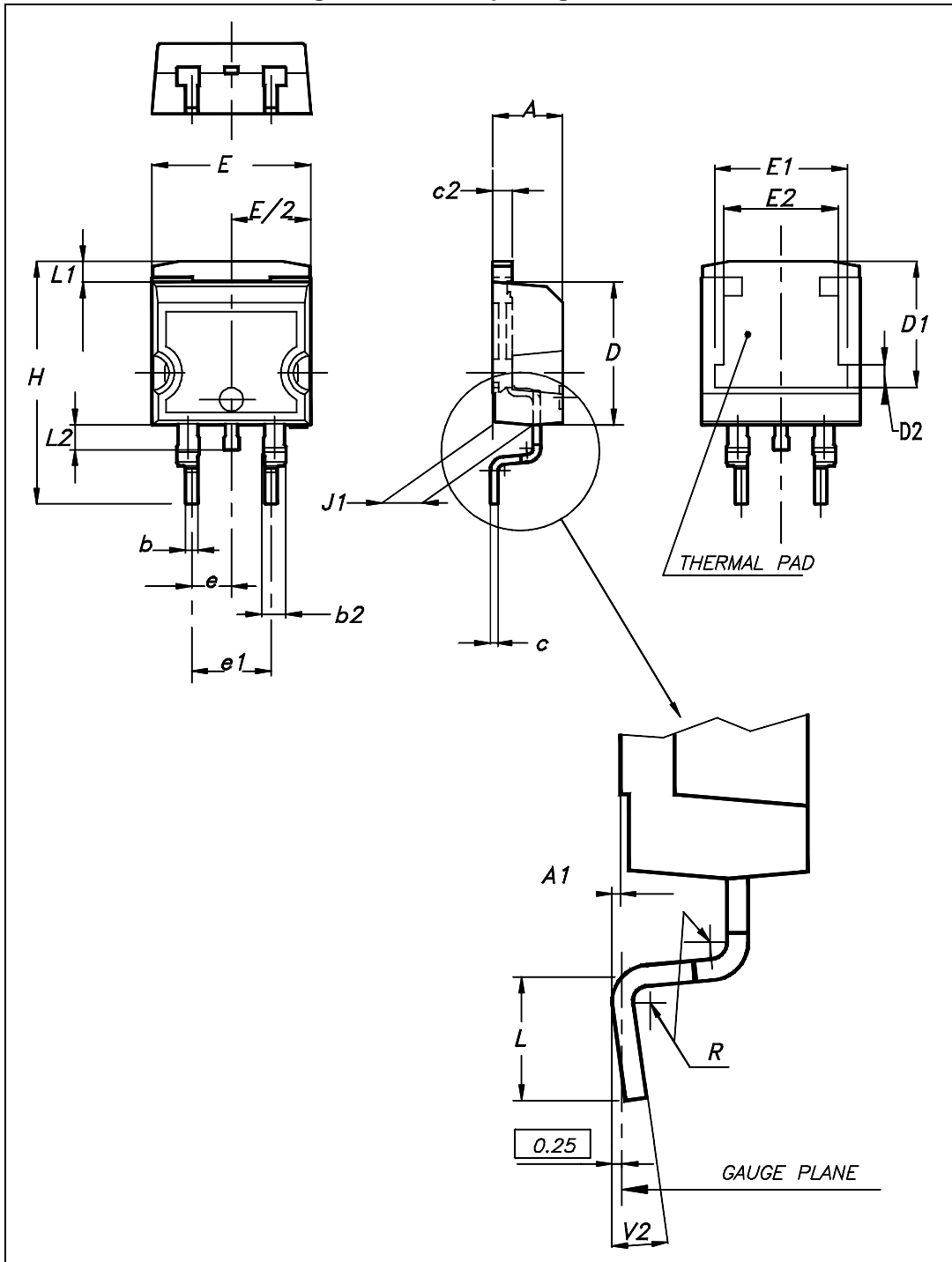
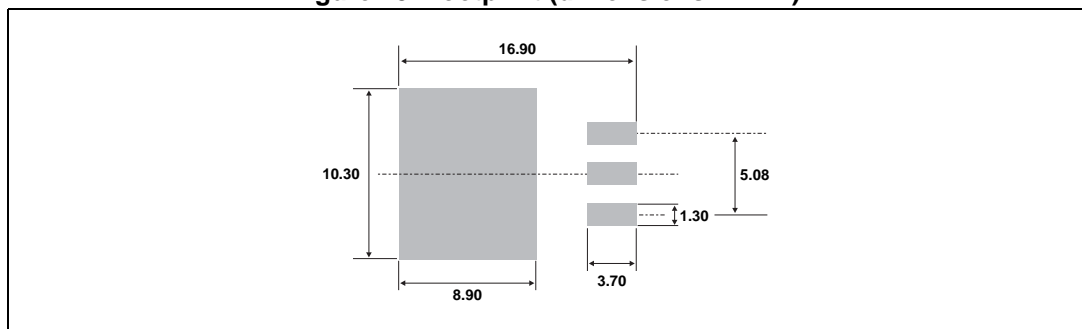

Table 8. D<sup>2</sup>PAK package mechanical data

Ref.	Dimensions			
	Millimeters		Inches	
	Min.	Max.	Min.	Max.
A	4.40	4.60	0.1739	0.1818
A1	2.49	2.69	0.0984	0.1063
A2	0.03	0.23	0.0012	0.0091
B	0.70	0.93	0.0277	0.0368
B2	1.14	1.70	0.0451	0.0672
C	0.45	0.60	0.0178	0.0237
C2	1.23	1.36	0.0486	0.0538
D	8.95	9.35	0.3538	0.3696
E	10.00	10.40	0.3953	0.4111
G	4.88	5.28	0.1929	0.2087
L	15.00	15.85	0.5929	0.6265
L2	1.27	1.40	0.0502	0.0553
L3	1.40	1.75	0.0553	0.0692
M	2.40	3.20	0.0949	0.1265
R	0.40 typ.		0.0158 typ.	
V2	0°	8°	0°	8°

Figure 23. Footprint (dimensions in mm)



## 5 Ordering information

**Table 9. Ordering information**

Order code	Marking	Package	Weight	Base qty	Packing mode
ACST830-8FP	ACST8308	TO-220FPAB	2.4 g	50	Tube
ACST830-8T		TO-220AB	2.3 g	50	Tube
ACST830-8GTR		D <sup>2</sup> PAK	1.5 g	500	Tape and reel

## 6 Revision history

**Table 10. Document revision history**

Date	Revision	Changes
Jan-2002	4B	Last update.
08-Nov-2004	5	TO-220AB and D <sup>2</sup> PAK packages added.
24-Nov-2004	6	Table 6 page 3: I <sub>GT</sub> parameter added
18-Dec-2009	7	Added ECOPACK statement. Reformatted for consistency with other datasheets in this product class. Order codes updated.
01-Jul-2010	8	Updated <i>Figure 19</i> .
07-Feb-2011	9	Updated <i>Table 2</i> .
04-Sep-2017	10	Updated features in cover page and <a href="#">Table 2</a> . Updated <a href="#">Section 4: Package information</a> . Minor text changes.



**IMPORTANT NOTICE – PLEASE READ CAREFULLY**

STMicroelectronics NV and its subsidiaries ("ST") reserve the right to make changes, corrections, enhancements, modifications, and improvements to ST products and/or to this document at any time without notice. Purchasers should obtain the latest relevant information on ST products before placing orders. ST products are sold pursuant to ST's terms and conditions of sale in place at the time of order acknowledgement.

Purchasers are solely responsible for the choice, selection, and use of ST products and ST assumes no liability for application assistance or the design of Purchasers' products.

No license, express or implied, to any intellectual property right is granted by ST herein.

Resale of ST products with provisions different from the information set forth herein shall void any warranty granted by ST for such product.

ST and the ST logo are trademarks of ST. All other product or service names are the property of their respective owners.

Information in this document supersedes and replaces information previously supplied in any prior versions of this document.

© 2017 STMicroelectronics – All rights reserved



Компания «Океан Электроники» предлагает заключение долгосрочных отношений при поставках импортных электронных компонентов на взаимовыгодных условиях!

Наши преимущества:

- Поставка оригинальных импортных электронных компонентов напрямую с производств Америки, Европы и Азии, а так же с крупнейших складов мира;
- Широкая линейка поставок активных и пассивных импортных электронных компонентов (более 30 млн. наименований);
- Поставка сложных, дефицитных, либо снятых с производства позиций;
- Оперативные сроки поставки под заказ (от 5 рабочих дней);
- Экспресс доставка в любую точку России;
- Помощь Конструкторского Отдела и консультации квалифицированных инженеров;
- Техническая поддержка проекта, помощь в подборе аналогов, поставка прототипов;
- Поставка электронных компонентов под контролем ВП;
- Система менеджмента качества сертифицирована по Международному стандарту ISO 9001;
- При необходимости вся продукция военного и аэрокосмического назначения проходит испытания и сертификацию в лаборатории (по согласованию с заказчиком);
- Поставка специализированных компонентов военного и аэрокосмического уровня качества (Xilinx, Altera, Analog Devices, Intersil, Interpoint, Microsemi, Actel, Aeroflex, Peregrine, VPT, Syfer, Eurofarad, Texas Instruments, MS Kennedy, Miteq, Cobham, E2V, MA-COM, Hittite, Mini-Circuits, General Dynamics и др.);

Компания «Океан Электроники» является официальным дистрибьютором и эксклюзивным представителем в России одного из крупнейших производителей разъемов военного и аэрокосмического назначения «JONHON», а так же официальным дистрибьютором и эксклюзивным представителем в России производителя высокотехнологичных и надежных решений для передачи СВЧ сигналов «FORSTAR».



## JONHON

«JONHON» (основан в 1970 г.)

Разъемы специального, военного и аэрокосмического назначения:

(Применяются в военной, авиационной, аэрокосмической, морской, железнодорожной, горно- и нефтедобывающей отраслях промышленности)

«FORSTAR» (основан в 1998 г.)

ВЧ соединители, коаксиальные кабели,  
кабельные сборки и микроволновые компоненты:

(Применяются в телекоммуникациях гражданского и специального назначения, в средствах связи, РЛС, а так же военной, авиационной и аэрокосмической отраслях промышленности).



Телефон: 8 (812) 309-75-97 (многоканальный)

Факс: 8 (812) 320-03-32

Электронная почта: [ocean@oceanchips.ru](mailto:ocean@oceanchips.ru)

Web: <http://oceanchips.ru/>

Адрес: 198099, г. Санкт-Петербург, ул. Калинина, д. 2, корп. 4, лит. А